

# Small Ruminant Resource Manual



## Navigating with Bookmarks

This document uses bookmarks that allow users to jump easily between different topic areas. These bookmarks give an overview – much like a table of contents – of the various topics and subtopics in this document. Clicking one of them takes you directly to its location.

1. Note the Bookmarks pane to the left of the document. If the Bookmarks pane is not displayed, click on the Bookmarks tab or go to < View < Navigation Tabs < Bookmarks.
2. To see sublevel bookmarks, expand the list by clicking the plus (+) next to the bookmark. To see only the top level bookmarks, collapse the list by clicking the minus (-) next to the bookmark.
3. To go to the section/topic indicated by the bookmark, click on the bookmark.

Production of the Small Ruminant Resource Manual and the presentation of this workshop have been made possible by funding from the Southern Sustainable Agriculture Research and Education Professional Development Program and the USDA Rural Business-Cooperative Services.



Permission was granted by the copyright owners to upload the previously published articles and publications that are available through the CD. Reproducing or reprinting this material for other uses may require the explicit consent of the copyright owners.

The National Sustainable Agriculture Information Service, ATTRA, was developed and is managed by the National Center for Appropriate Technology (NCAT). The project is funded through a cooperative agreement with the United States Department of Agriculture's Rural Business-Cooperative Service. Visit the NCAT Web site ([www.ncat.org/sarc\\_current.php](http://www.ncat.org/sarc_current.php)) for more information on our other sustainable agriculture and energy projects.

For more information,  
visit our Web site [www.attra.ncat.org](http://www.attra.ncat.org)  
or call our toll-free number  
**1-800-346-9140**



# Whole Farm Planning



In this section:

- [Small Ruminant Checksheet—Quick Start](#)
- [Small Ruminant Sustainability Checksheet](#)
- [Small Ruminant Resources](#)
- [Holistic Management](#)

# Small Ruminant Checksheet

## Quick Start

By Linda Coffey and  
 Margo Hale, NCAT  
 Agriculture Specialists  
 © 2010 NCAT

These questions are bottom-line questions about components of your farm. If your answer to a question is “yes,” proceed to the following question. If the answer is “no,” mark the question and investigate options for strengthening that component by turning to the relevant section of the *Small Ruminant Sustainability Checksheet*, which is found on the page listed in parentheses.

### Forages

- | YES                      | NO                       |   |
|--------------------------|--------------------------|---|
| <input type="checkbox"/> | <input type="checkbox"/> | <b>1. <u>Inventory</u> (page 8)</b>   |
| <input type="checkbox"/> | <input type="checkbox"/> | ▶ Do you have a grazing system plan that ensures you are grazing in the most efficient manner possible? |
| <input type="checkbox"/> | <input type="checkbox"/> | <b>2. <u>Utilization</u> (page 9)</b>   |
| <input type="checkbox"/> | <input type="checkbox"/> | ▶ Do you have the right number of animals on your farm?   |
| <input type="checkbox"/> | <input type="checkbox"/> | ▶ Do you have adequate forage year-round?   |
| <input type="checkbox"/> | <input type="checkbox"/> | ▶ Are you making full use of your available forage?   |

### Livestock

- |                          |                          |   |
|--------------------------|--------------------------|---|
| <input type="checkbox"/> | <input type="checkbox"/> | <b>1. <u>Nutrition</u> (page 11)</b>  |
| <input type="checkbox"/> | <input type="checkbox"/> | ▶ Do your animals appear to be lively, healthy, and vigorous?                                     |
| <input type="checkbox"/> | <input type="checkbox"/> | ▶ Do your animals have appropriate condition (fat cover) for the stage of production they are in? |
| <input type="checkbox"/> | <input type="checkbox"/> | <b>2. <u>Observation</u> (page 15)</b>  |
| <input type="checkbox"/> | <input type="checkbox"/> | ▶ Do you check your animals daily?  |
| <input type="checkbox"/> | <input type="checkbox"/> | ▶ Do you know the look and behavior of a healthy animal?  |
| <input type="checkbox"/> | <input type="checkbox"/> | ▶ Do you act promptly when you observe an animal that is not acting “right”?                      |
| <input type="checkbox"/> | <input type="checkbox"/> | <b>3. <u>Parasites</u> (page 16)</b>  |
| <input type="checkbox"/> | <input type="checkbox"/> | ▶ Are parasites kept at a level that does not affect animal performance?                          |
| <input type="checkbox"/> | <input type="checkbox"/> | ▶ Do you use a variety of practices to reduce and/or avoid resistant parasites?                   |
| <input type="checkbox"/> | <input type="checkbox"/> | <b>4. <u>Sanitation</u> (page 17)</b>   |
| <input type="checkbox"/> | <input type="checkbox"/> | ▶ Is sanitation generally good?   |
| <input type="checkbox"/> | <input type="checkbox"/> | ▶ Do you use preventative measures toward all disease on your farm?                               |
| <input type="checkbox"/> | <input type="checkbox"/> | <b>5. <u>Predator Control</u> (page 18)</b>   |
| <input type="checkbox"/> | <input type="checkbox"/> | ▶ Are your animals safe from predators?   |
| <input type="checkbox"/> | <input type="checkbox"/> | <b>6. <u>Reproduction</u> (page 19)</b>   |
| <input type="checkbox"/> | <input type="checkbox"/> | ▶ Are you satisfied with your lambing or kidding percentage?                                      |
| <input type="checkbox"/> | <input type="checkbox"/> | ▶ Does your farm depend on a high level of reproduction?  |
| <input type="checkbox"/> | <input type="checkbox"/> | <b>7. <u>Breeding and Selection</u> (page 20)</b>   |
|                          |                          | ▶ Are you satisfied with the performance of your current breeding animals in the following areas? |
|                          |                          | • Number of kids or lambs weaned  |
|                          |                          | • Weaning weights   |

YES NO

- Milk production
- Health and longevity

➤ Are your animals suited to your management and your market?

### **Marketing (page 22)**

➤ Are you selling your products for the best possible price?

➤ Are you timing production to ensure the best price?

➤ Are you selling all the products from your farm?

### **Records (page 24)**

➤ Do you use records for management decisions and future planning?

### **Economics (page 25)**

➤ Can you make a good profit after feed and other costs are paid?

➤ If you are selling a processed product, are you being compensated for the extra time you have invested?

### **Quality of Life (page 30)**

➤ Is there enough labor available at all times of the year?

➤ Do the people involved in the care of the animals like to work with sheep or goats?

### **Systems Management**

#### **1. Timing (page 31)**

➤ Are you timing lambing or kidding in order to make the best use of your resources and maximize profit?

#### **2. Coordinating Enterprises (page 33)**

➤ Do each of your enterprises bring benefits to your farm as a whole?

➤ Do your enterprises complement one another?

### **Conclusion (page 35)**

➤ Have you identified the weak links of your whole farm?



#### **Small Ruminant Checklist Quick Start**

By Linda Coffey and Margo Hale, NCAT Agriculture Specialists

© 2010 NCAT

Holly Michels, Editor • Robyn Metzger, Production

This publication is available on the Web at:

[www.attra.ncat.org/attra-pub/quickstart.html](http://www.attra.ncat.org/attra-pub/quickstart.html)

or

[www.attra.ncat.org/attra-pub/PDF/quickstart.pdf](http://www.attra.ncat.org/attra-pub/PDF/quickstart.pdf)

IP259

Slot 259

Version 091510

# Small Ruminant Sustainability Checksheet

By Linda Coffey, Jana Reynolds and Margo Hale, NCAT Agriculture Specialists

Updated by Linda Coffey, Margo Hale and Hannah Lewis, NCAT Agriculture Specialists  
© 2010 NCAT

This checksheet is designed to stimulate critical thinking when evaluating a farm that produces sheep or goats. The sustainability of a farm depends on many factors involving farm management, use of resources, and quality of life. The questions in this checksheet are intended to stimulate awareness rather than to rate management practices. Use this guide to define areas in your farm management that might be improved, as well as to identify areas of strength.



## Suggestions on how to use the checksheet

This checksheet is designed to help educators assist producers in whole-farm planning. For a producer, working with an educator (Cooperative Extension agent, Young Farmer advisor, or NRCS specialist) to complete this checksheet will be beneficial, but is not essential. The checksheet is quite long, and it can be challenging to both educators and producers. Having evaluated the use of the checksheet on several farms, the authors make the following suggestions.

- Send the checksheet to the producer before your first meeting. Allow one to two weeks for the producer to work through it.
- Review the questions beforehand and be flexible. The producer and educator should be comfortable working through the process. Remember that the checksheet is simply a guide to planning new enterprises or to assess an existing operation's strengths and weaknesses.
- The questions have been worded so that "yes" answers indicate a strength or good understanding of management or marketing techniques, while "no" answers show areas where improvements or more information may be needed. The number of "yes" and "no" answers for each section should be entered into the Farm Action Plan, which serves as a summary of the checksheet and will help the farmer prioritize areas to improve.
- The Quick Start option is intended for producers who may not need to work through the entire checksheet. The Quick Start provides an easy assessment tool to show quickly what areas need attention. Producers can then focus on the sections of the checksheet that address the weaker areas of their operation.
- Enterprise and financial records will be essential to the completion of this checksheet. Having aerial photos, soil maps, and topographic maps on hand during the assessment is also useful.
- Since the time needed to work completely through the checksheet (about 2 ½ hours) may be longer than available for a single farm visit, two or more visits may be in order. The checksheet is useful in making the producer aware of management alternatives. Therefore, defining the items for which he or she needs more information is most important.
- Support materials to refer to during the assessment are available from ATTRA.
- Ideally, producers will use the checksheet each year to track their progress and to continually refine their farm plans.



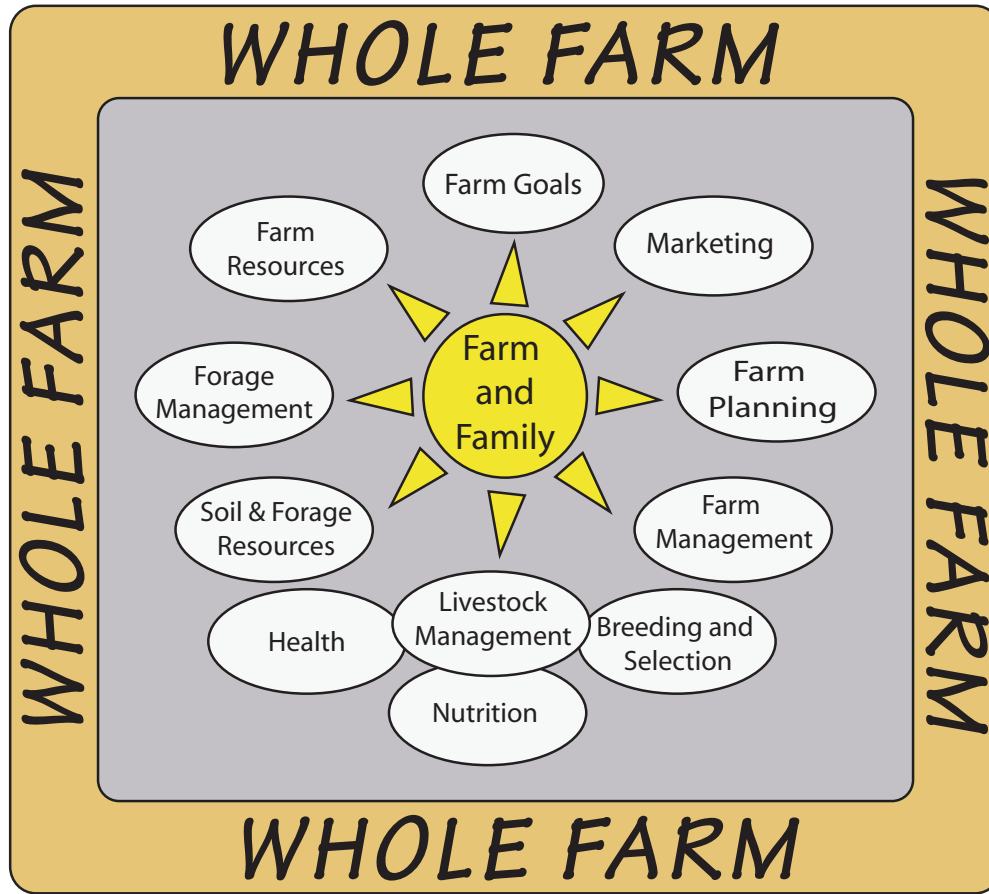

## Table of Contents

Quick Start .....	3	3. Breeding and Selection .....	20
I. Introduction .....	5	C. Marketing .....	22
II. Farm Resources Inventory .....	6	D. Records .....	24
III. Farm Planning .....	7	E. Economics .....	25
IV. Farm Management .....	7	F. Quality of Life.....	30
A. Forages .....	8	G. Areas to Improve.....	31
1. Inventory .....	8	V. Systems Management .....	31
2. Utilization .....	9	A. Timing .....	31
B. Livestock .....	11	B. Coordinating Enterprises.....	33
1. Nutrition .....	11	VI. Conclusion .....	35
2. Health .....	14	Farm Action Plan .....	36
a. Observation of Animals.....	15	Appendix A: About Organic Production .....	37
b. Parasites.....	16	Appendix B: Diseases in Flock or Herd .....	39
c. Sanitation.....	17	Appendix C: Resource Assessments .....	40
d. Predator Control.....	18	Appendix D: Small Ruminant Resources .....	43
e. Reproduction .....	19		

## Quick Start

These questions are bottom-line questions about components of your farm. If your answer to a question is “yes,” proceed to the following question. If the answer is “no,” mark the question and investigate options for strengthening that component by turning to the relevant section of the *Small Ruminant Sustainability Checksheet*, which is found on the page listed in parentheses.

### Forages

YES NO 1. **Inventory (page 8)**

- Do you have a grazing system plan that ensures you are grazing in the most efficient manner possible?

2. **Utilization (page 9)**

- Do you have the right number of animals on your farm?  
  ➤ Do you have adequate forage year-round?  
  ➤ Are you making full use of your available forage?

### Livestock

1. **Nutrition (page 11)**

- Do your animals appear to be lively, healthy, and vigorous?  
  ➤ Do your animals have appropriate condition (fat cover) for the stage of production they are in?

2. **Observation (page 15)**

- Do you check your animals daily?  
  ➤ Do you know the look and behavior of a healthy animal?  
  ➤ Do you act promptly when you observe an animal that is not acting “right”?

3. **Parasites (page 16)**

- Are parasites kept at a level that does not affect animal performance?  
  ➤ Do you use a variety of practices to reduce and/or avoid resistant parasites?

4. **Sanitation (page 17)**

- Is sanitation generally good?  
  ➤ Do you use preventative measures toward all disease on your farm?

5. **Predator Control (page 18)**

- Are your animals safe from predators?

6. **Reproduction (page 19)**

- Are you satisfied with your lambing or kidding percentage?  
  ➤ Does your farm depend on a high level of reproduction?

7. **Breeding and Selection (page 20)**

- Are you satisfied with the performance of your current breeding animals in the following areas?
- Number of kids or lambs weaned
  - Weaning weights
  - Milk production
  - Health and longevity
- Are your animals suited to your management and your market?

### Marketing (page 22)

- Are you selling your products for the best possible price?  
  ➤ Are you timing production to ensure the best price?

YES NO

- Are you selling all the products from your farm?

### **Records (page 24)**

- Do you use records for management decisions and future planning?

### **Economics (page 25)**

- Can you make a good profit after feed and other costs are paid?  
  ➤ If you are selling a processed product, are you being compensated for the extra time you have invested?

### **Quality of Life (page 30)**

- Is there enough labor available at all times of the year?  
  ➤ Do the people involved in the care of the animals like to work with sheep or goats?

### **Systems Management**

#### **1. Timing (page 31)**

- Are you timing lambing or kidding in order to make the best use of your resources and maximize profit?

#### **2. Coordinating Enterprises (page 33)**

- Do each of your enterprises bring benefits to your farm as a whole?  
  ➤ Do your enterprises complement one another?

### **Conclusion (page 35)**

- Have you identified the weak links of your whole farm?



# I. Introduction

This checksheet is designed to help farmers think about individual aspects of their farms, as if each aspect were part of a puzzle, and then to consider how the pieces best fit together to form a whole farm. Other ATTRA checksheets have focused on beef, dairy cattle, and organic livestock production. This one looks at small ruminants, sheep and goats.

Sustainability in agriculture means being economically viable, maintaining or improving the environment (land, air, water), and providing an enjoyable life for the farming family. Each of these is essential to long-term viability, and management decisions will have an impact on at least one of these components, and frequently all three. For example, choosing to increase the size of a flock will change how much money flows in and out, place greater demands on the land and water, and can require more time and labor from the family.



Small ruminants fit into a sustainable farm in a variety of ways. First of all, their grazing preferences make them ideal animals to feed on weeds, brush, and other plants that cattle often won't eat. (Multiflora rose and pigweed are two notorious examples.) Because they are smaller than cattle, sheep and goats are less likely to cause pugging on wet soils, are easier to work with, cheaper to buy and maintain, and need less equipment. They are prolific and do well on forages. Their products are easy to market, once a market is found, and current prices for goats and lambs are very good. Also, because goats and sheep mature quickly and have a short gestation, farmers can have products to sell very quickly, improving their cash flow. And herd and flock sizes can be rapidly increased. Return on investment is usually better for small ruminant enterprises than for cattle. However, profitability depends on how a farm is managed.

In the rush of daily life, we often fail to take the time to look critically at our farms and the decisions we've made or to explore the many options available. By using this checksheet to examine your farm in detail, you and your family will be better equipped to evaluate and improve the sustainability of your farm. To meet that goal, it is best that you work through this checksheet together, marking questions that need to be explored further and making notes about ideas that occur as you talk about your farm. Further information is available from your local Cooperative Extension agent, Natural Resources Conservation Service (NRCS) agent, the ATTRA National Sustainable Agriculture Information Service, and many other sources. Some of those are referred to throughout the text, and more are included in the Resources at the end of the checksheet.

Keeping in mind the three components of sustainability—economic, environmental, and social—look at each aspect of your farm and evaluate how well it is currently working. If you need to make changes, plan carefully, implement, observe, and evaluate the results and their impacts on all three aspects of sustainability. Careful attention to these concepts can result in a farm that is more profitable, has healthier soil, water, animals, and air, and is enjoyable for the farm family.

## II. Farm Resources Inventory

Your farm is unique, and the soils, topography, water, forages, climate, and location will enter into your decisions about what crops and livestock to raise. This section is meant to give a “snapshot” of your farm as it is now.

YES NO

1. What size is your farm? How many total acres? \_\_\_\_\_
2. How many acres are productive or currently being used? \_\_\_\_\_
3. What are the soils like? (deep loams, rocky, sandy, clay) \_\_\_\_\_
4. Have you visited with your NRCS and/or local Extension agent about a soil survey or farm plan?
5. Have you conducted soil tests in the past three years?
6. Do you know how to read a soil test and use the results?
7. What are the nutrient levels in the soils? (Get this information for each field; write it on another page and attach it to this document for future reference and to observe changes over time.)  
Organic matter \_\_\_\_\_ pH \_\_\_\_\_ P \_\_\_\_\_ K \_\_\_\_\_
8. How and when do you fertilize your fields? \_\_\_\_\_
9. What is the topography of your farm? (flat, sloped, steep slopes, rugged, etc.)  
\_\_\_\_\_
10. Do you have a plan to minimize erosion and maintain vegetation on your land?
11. What water sources are currently available? \_\_\_\_\_
12. What other water sources are potentially feasible? \_\_\_\_\_
13. How much land is dedicated to production for market? \_\_\_\_\_
14. What crops are grown on your farm? \_\_\_\_\_
15. What forages are grown on your farm? \_\_\_\_\_
16. Do you practice rotational grazing?
17. If so, how many pastures are used in rotation? \_\_\_\_\_
18. Does your farm include any brushy areas? \_\_\_\_\_
19. How many and what types of livestock do you currently raise? \_\_\_\_\_
20. What other species would you like to raise? (crops or livestock) \_\_\_\_\_
21. When are young stock born on your farm? (kids, lambs, or other animals)  
\_\_\_\_\_
22. How, where, and when do you market your crops or other farm products?  
\_\_\_\_\_
23. Write down any other pertinent information about your farm, its land, water, soil, climate and crops or products. \_\_\_\_\_  
\_\_\_\_\_  
\_\_\_\_\_

**Total yes answers** \_\_\_\_\_ **Total no answers** \_\_\_\_\_

**Enter these numbers on the Farm Action Plan, pg. 36**

### III. Farm Planning

---

**W**hole Farm Planning is the important process of evaluating your farm, examining your goals, thinking about all your available resources, and then determining how best to use those resources to meet your goals. The enterprises chosen for the farm must be compatible with the resources available. Having thought about the individual features of your farm, you are now in position to assess how well the different areas are working together. Answering the following questions will help as you develop a plan for the future.

1. What are the top five strengths of your operation? \_\_\_\_\_

\_\_\_\_\_

2. What are the top five problems of your operation? \_\_\_\_\_

\_\_\_\_\_

3. What are the top three goals for your operation? \_\_\_\_\_

\_\_\_\_\_

4. What resources do you have that can give you a competitive advantage over the average producer (to lower production costs or enhance marketing efforts, for example)? \_\_\_\_\_

\_\_\_\_\_

### IV. Farm Management

---

**I**n this section, you are asked to look more closely at each component of your farm—livestock, forages, marketing, records, economics, and quality of life—and to look for areas to improve. Give special attention throughout to ways to improve sustainability.

Sustainability as applied to a sheep or goat farm might incorporate healthy, properly fed animals that breed easily, milk well, have a good rate of growth, and hardy constitutions. They should be well suited to the climate and to the feed available. Productive, nutritious pastures with good forage cover and, therefore, minimal erosion, healthy soil with good organic matter and fertility, and fences and facilities that function well are all further indicators of a sustainable farm. This farm should be attractive and managed by farmers who are in general happy, healthy, and in agreement with family members. Products sold from a sustainable farm should be in high demand, sell for a consistently profitable price (including labor cost), and be of consistently high quality to ensure continued demand.

Debt should not be crushing. Costs must be kept in line, and new ideas to increase profitability should be explored. Marketing must be a constant activity, and someone reliable must be in charge of this crucial area. The farm must be in compliance with laws and regulations, and the whole operation should work harmoniously.

#### **Keys to sustainable sheep and goat production:**

- Pastures must be managed to optimize nutritious, low-cost feed for the animals.
- Pastures must be managed to leave adequate residue (two to four inches minimum) of stubble, so that soils are protected and plants do not die out. (Ask a local agronomist about appropriate stubble height for the plants your animals are grazing.)

- Brush used as a feed source must be rested just as grassy pastures are rested, to avoid eradicating the brush. It may need to be rested a full year. If the objective is to kill the brush so that more grass can be grown, then the brush could be grazed more frequently.
- Animals must be kept healthy. Prevention is much cheaper and more effective than treatment; good management and good nutrition will do far more than drugs and be more economical and satisfying.
- Animals must be protected from predators.
- Animals must be productive in their environment. Selecting for twinning, milking, and mothering ability, fiber production, rate of gain, parasite resistance, good disposition, longevity—or whatever meets your goals—will lead to consistently better animals in your flock or herd over time.
- All products should be sold at a fair price; meat, fiber, milk, hides, manure, and grazing services are all potential products. More than one option should be feasible. Greater diversity of products can help reduce economic risk, but that diversity may also reduce critical time for marketing and require more equipment.
- If time and markets permit, value-added products are a way to increase income. For example, direct-marketing meat may return more profit than selling live animals at the sale barn; selling cheese may be more profitable than selling fluid milk. Careful research and budgeting are necessary before undertaking a new enterprise, and you must comply with federal, state, and local regulations.
- Producing certified organic products might be a way to increase income, but it is important to assess carefully the additional costs involved in running a certified organic operation. These include higher prices for feed, fewer options for processing meat, more record-keeping, and annual certification fees. In this checksheet, we have included a few fundamental questions to help you assess whether organic production is feasible and advantageous for you. These questions represent the “tip of the iceberg,” and you are encouraged to read carefully the resources listed at the end of the publication to get a fuller picture of what’s involved. *NCAT’s Organic Livestock Workbook* will be especially helpful and will be referred to often in the sections about organic production.

A problem in any of these areas (animals, forages, marketing, economics) will have a negative impact on the enterprise. The following questions are to help you explore the specific areas of your farm that might be improved to increase your farm profitability.

## A. Forages

### 1. Inventory

YES NO

1. What types of forages are available on your farm? \_\_\_\_\_
2. Do you have a variety of different forage species available? How many? \_\_\_\_\_
3. How many acres of the following types of forage do you have on your farm? (See your NRCS agent for help with this—aerial photos can help you quantify.) \_\_\_\_\_
  - Predominately cool season forages
  - Predominately warm season forages
  - Mixture of warm and cool season forages
4. Do you have pastures with: (estimate percentage of your farm in each category)
 

_____ Legumes	_____ Cool season annuals	_____ Warm season annuals
_____ Brush and weeds	_____ Crop residue	
_____ Pastures that can be stockpiled (held) for late fall/winter grazing		
5. Do you use a rotational grazing system? If so, how intensively do you manage the grazing?  
 \_\_\_\_\_
6. Do you use cross fences to improve pasture use?

YES NO

- 7. How many days do your animals get most of their nutrition from grazing? \_\_\_\_\_  
How could that be increased? \_\_\_\_\_
- 8. When do you typically start grazing in the spring? \_\_\_\_\_
- 9. When do you usually stop grazing in the fall/winter? \_\_\_\_\_
- 10. When would you like to begin and end your grazing season? \_\_\_\_\_
- 11. Are you grazing enough to minimize feed costs?
- 12. Could you use crop residue?
- 13. When do you have the most forage available? \_\_\_\_\_
- 14. Does that coincide with lambing or kidding?
- 15. When is your best quality forage ready to graze? \_\_\_\_\_
- 16. Could you graze a neighbor's land?
- 17. What do you consider to be a weed on your farm? \_\_\_\_\_  
Could it be a resource for you? \_\_\_\_\_

**For organic farmers, or those transitioning to organic:**

- 18. Do you have enough acres of organically managed land to provide 100% organic feed for your livestock? See NCAT's *Organic Livestock Workbook* for more details, especially Units 1 and 2.
- 19. Do you have enough forages to provide at least 30% of the dry matter intake for your sheep and goats for the grazing season?
- 20. Is your grazing season at least 120 days long?
- 21. Do you have a plan for maintaining soil fertility without using chemical fertilizers?
- 22. Do you keep records, including soil maps, manure applications, harvest or grazing dates, soil and water test reports, seed tags, verification of organic status of seeds and sprigs purchased, and farm maps showing use of your fields and adjoining land? See NCAT's *Organic Livestock Workbook*, especially Units 2 and 4.

**Total yes answers \_\_\_\_\_ Total no answers \_\_\_\_\_**  
**Enter these numbers on the Farm Action Plan, pg. 36**

## 2. Utilization

- 18. List the numbers and kinds of animals you usually graze.  

_____	_____	_____	_____
animal	number	animal	number
- 19. What is your stocking rate? Looking at the year, are you under-stocked, over-stocked, or close to right? \_\_\_\_\_
- 20. What are the limiting factors in your grazing season/ system?
  - \_\_ Drought
  - \_\_ Rainfall distribution
  - \_\_ Soil fertility or type
  - \_\_ Availability of drinking water
  - \_\_ Poor stands of forage or low productivity of forage
  - \_\_ Lack of proper fencing
  - \_\_ Other(s) \_\_\_\_\_



YES NO

21. Do you know how to recognize characteristics of an overgrazed pasture?
- Forages grazed shorter than two inches (some forages are overgrazed at six inches)
  - Very slow re-growth of forages
  - Animals do not stay in their pasture
  - Animals appear hungry
  - Bare patches or areas that do not recover from grazing
  - Weed invasion where grasses have been suppressed
  - Reduced longevity of pasture stands
  - Increased erosion due to more exposed soil
22. Do you have a strategy for dealing with a shortage of forage?
- Access to other pastures
  - Reduce animal numbers by marketing
  - Offer supplemental feed
  - Other \_\_\_\_\_
- 
23. Do you know how to recognize characteristics of underutilized pastures?
- Patches of over-mature forage and seed heads
  - Forage wasted due to trampling
  - Loss of low-growing plants due to shading
  - Spot-grazing
  - Increase in less-palatable forages due to overgrazing of preferred forages
  - Reduction in quality of forage due to maturation
  - Excessive dead material, which suppresses new growth
24. Do you have a strategy for dealing with excess forage?
- Harvest hay
  - Increase animal numbers
  - Lease extra pastures to other livestock producers
  - Mow to keep pastures vegetative
25. How many days do you have to supply supplemental feed? \_\_\_\_\_
26. What is your winter feeding program? \_\_\_\_\_
27. Are you grazing year-round?
28. What can you do to extend your grazing season? \_\_\_\_\_



If you are organic or transitioning to organic, please see *NCAT's Organic Livestock Workbook*, Section 2, for extensive questions to assess this aspect of your farm. In order to comply with the National Organic Program, you must apply good management practices, as outlined above. You must also provide 100% organic feed, and at least 120 days of grazing, during which at least 30% of dry matter intake comes from pasture. For more information about the pasture rule, see [www.nodpa.com/pasture\\_rule.shtml](http://www.nodpa.com/pasture_rule.shtml) (especially the Resources section, which includes record forms to assist farmers in collecting information about pasture use).

For more information about the standards relating to organic pasture, *NCAT's Organic Livestock Workbook* and *Highlights* (both available from ATTRA, 800-346-9140) will be useful.

**YES NO**

29. Are you managing your pastures in a way that protects soil and water quality?
30. Are you managing your pastures so that they contribute to biodiversity? (e.g., encourage beneficial insects, offer diverse forages, have field edges that encourage birds and insects and wildlife. See [www.wildfarmalliance.org/resources/BD%20Guide%20Organic%20Farmers%20.pdf](http://www.wildfarmalliance.org/resources/BD%20Guide%20Organic%20Farmers%20.pdf) for many more ideas. See also the Wild Farm Alliance page at [www.wildfarmalliance.org/resources/organic\\_BD.htm](http://www.wildfarmalliance.org/resources/organic_BD.htm) for a compliance checklist on this aspect of organic production.)
31. Do you maintain the fertility of your land without using chemical fertilizers?
32. Do you control weeds or insects (if necessary) without using chemical herbicides or pesticides?

\*\* Review the above section and make any notes about potential improvements, problems to solve, limitations to overcome. \_\_\_\_\_

\_\_\_\_\_

\_\_\_\_\_

**Total yes answers \_\_\_\_\_ Total no answers \_\_\_\_\_**  
**Enter these numbers on the Farm Action Plan, pg. 36**

## ***B. Livestock***

### **1. Nutrition**

Proper nutrition is crucial to the health and productivity of your animals. Attention to their body condition and behavior while grazing helps assess the condition of the pasture. Remember that for sheep and goats, having enough quality forage is important. Overgrazing an area forces animals to consume more parasite larvae. Goats will do well on browse, whereas sheep are better at using grasses, clovers, and weeds. Cattle prefer to graze grasses. The feed resources available on your farm will help determine which animals you can raise most profitably, because an ample supply of forage will greatly reduce the cost of raising ruminant livestock. If your farm offers a mixture of forage types, then grazing multiple species will ensure the best use of the available feed and will help maintain your farm. Cattle will eat over-mature forage and make pastures better for sheep; sheep will graze weeds, and goats will eat brushy plants so that pastures are better for cattle. Cattle also help break internal parasite cycles, so sheep and goats grazed with cattle may be healthier and gain weight more easily.

Sheep and goats can be raised entirely on forage in many areas, though their performance will be improved by offering some supplemental feed at certain times of the year— just before and during breeding season (flushing), during the last month of pregnancy, and during the first weeks of lactation for sheep or meat goats. Dairy goats require more supplemental feed to sustain a long, high-yielding lactation. The need will be greatly reduced if excellent pasture and browse are available. Supplemental mineral needs will vary by location.

To be sustainable, nutrition programs must not only meet the animal's needs but do so economically. Generally speaking, commercial rations will be expensive, and generous feeding of concentrates (grain) and of top-quality hay may lead to animals that are too fat, unproductive, and unprofitable. Allowing the animals to graze and browse will be better for the land, as manure will enrich the soil and help build organic matter; better for the animals, as they will get plenty of exercise and lots of forage, which is what they are designed to eat; and better for the bank account, as letting the animals graze and browse is the cheapest way to feed them.

Besides providing plenty of growing or stockpiled forages, a good stockman will be sure to offer lots of clean water and free-choice mineral mix. Sheep and goats differ in their tolerance to copper, with goats needing more and sheep suffering toxicity if dietary levels are more than 25 parts per million. Because copper is present in forage, and is higher in forage that has been fertilized with poultry litter, it is important to test forage mineral levels and choose a mineral supplement accordingly. Goat and cattle minerals contain varying levels of copper, whereas sheep mineral supplements usually do not contain copper. Be sure to check labels. It is also important to know the relative availability of mineral sources—that is, how much of the mineral an animal can metabolize and use. Some forms are more available than others. For example, the copper in copper oxide is only about 10% available (or less), whereas copper sulfate is highly available.

For organic producers, as well as for everyone else, good nutrition is essential for animal health and productivity. Organic producers have to provide a diet that is 100% organic, with access to pasture, at least 120-day grazing season, and enough pasture to provide at least 30% of the dry matter intake of all the ruminant animals during the grazing season. You must use only organically approved supplements. Because all feed must be certified organic, it is important to have a backup plan in case a supplier has problems meeting your needs; you must save all feed tags and records, keep rations for all classes of livestock on your farm, and keep harvest and grazing records.

**YES NO**

- 1. Do your animals appear to be lively, healthy, and vigorous?
- 2. Is the manure a proper consistency (pellets, except when on lush spring pastures)?
- 3. Do your animals reach market weight or breeding weight at appropriate ages?
- 4. If some animals are not growing well, is it due to a health problem? Lack of quantity or quality of feed? Poor milking mothers? \_\_\_\_\_
- 5. Do you know how to check your animals' body condition score (1-5)? (see [www.luresext.edu/goats/research/bcshowto.html](http://www.luresext.edu/goats/research/bcshowto.html))
- 6. Do you routinely check your animals' body condition (thin, average, fat)?
- 7. Do your animals have appropriate condition (fat cover) for the stage of production they are in?
- 8. Do you know how to bring your animals into proper condition for their stage of growth, pregnancy, or lactation?
- 9. If they are too fat, can you adjust their condition by putting them in an area of lower quality forage?

\*\* Review the questions above and note any adjustments that can be made or information needed.

---



---



---



---

YES NO

10. Do you balance rations for your livestock?
11. Are you feeding an appropriate amount of concentrates? What do your sheep or goats eat year-round? Record here your usual feeding plan.
- \_\_\_\_\_
- \_\_\_\_\_
- \_\_\_\_\_
12. What is your cost per head for supplemental feed? \_\_\_\_\_
13. What minerals are deficient or excessive in your area? \_\_\_\_\_
14. Does your mineral supplementation program adequately address these excesses or deficiencies?
15. Do you offer creep feed to nursing animals?
16. If so, is it profitable to creep feed your animals?
17. When do you feed hay? \_\_\_\_\_
18. What type of hay do you feed? \_\_\_\_\_
19. Have you tested your hay for protein and digestibility?
20. Is your hay good enough to meet protein, energy, and mineral requirements?
21. Do you use forage analysis results in balancing rations?
22. Is your hay of sufficient quality for the stage and level of production of your animals?
- \_\_ Is the color of the hay good?
- \_\_ Is the hay leafy?
- \_\_ Is the hay free of mold?
- \_\_ Was the hay harvested before maturity? (no seedheads present)
- \_\_ Was the hay baled in ideal conditions? (not rained on)
- \_\_ Was the hay properly handled and stored?
- \_\_ Is the hay digestible? (Refer to your forage test.)
- \_\_ Do the animals readily eat the hay?

**Stocking rate has an impact on nutrition (availability of quantity and quality of forage), sanitation, and parasite load of animals.**

Based on the evaluation of your forages, and considering the year as a whole,

23. Is your farm carrying the right number of animals?
- not overgrazed
  - not undergrazed
  - animals are healthy and well-nourished
  - hay expenditures are minimal
24. Are you providing your pastures enough rest? (This helps with pasture longevity and with breaking internal parasite cycles.)
25. Do you have a drought plan?

Total yes answers \_\_\_\_\_ Total no answers \_\_\_\_\_

Enter these numbers on the Farm Action Plan, pg. 36

**Organic producers: see NCAT's *Organic Livestock Workbook* for many questions regarding pasture, feeding, protecting the soil and water, and livestock living conditions.**

## 2. Health

Under good management (with good nutrition, careful handling, and attention to necessary duties and vaccinations, in a low-stress environment) and with good genetic makeup, sheep and goats are remarkably trouble-free, healthy, and hardy.

However, sheep and goats do not generally live in perfect conditions. Stress caused by over-crowding, mixing stock from multiple locations, unbalanced rations, and poor sanitation, for instance, may cause disease, and then small ruminants are unfairly judged with such comments as “a sick sheep is a dead sheep.”

Producers of small ruminants generally agree that one of their major challenges is to minimize the negative effects of internal parasites. Because of their ability to graze close to the ground, sheep and goats may easily consume the worm larvae that are deposited (as eggs) in manure. Some animals have a natural resistance to parasites and can inhibit parasite growth and reproduction. Other animals manage to carry heavy parasite loads and yet appear healthy. Still others, particularly young, lactating, or stressed animals, or those with little previous exposure, are highly susceptible to parasite infection and may become so damaged that they will never recover.

Because of this individual variation among animals, it is possible to make progress on your farm by selecting the individuals who resist internal parasites. It is estimated that 20% of the animals carry 80% of the worms and are, therefore, responsible for spreading the eggs on the pasture and infecting the rest of the herd or flock. If you can identify those main offenders and cull them, the whole farm benefits. You can identify the animals that are better able to handle internal parasites by checking for anemia (only for barberpole worm, *Haemonchus contortus*), doing fecal egg counts, and observing the animals—and in all those cases, by keeping and reviewing careful records.

Resting and rotating pastures and using cattle or horses to break the parasite cycle will help a great deal with internal parasite management. However, rotating back to an infected pasture just when the eggs are hatching will multiply problems. Resting pastures six weeks in warm weather will reduce contamination, and in hot, dry weather, resting only two weeks will help. Not grazing pasture shorter than three inches will also help, because the larvae crawl up the grass blades only a short distance (so most larvae are found near the soil surface). Cutting a pasture for hay and then allowing it to regrow will also reduce contamination.

For more information about managing internal parasites, see *Managing Internal Parasites in Sheep and Goats* ([www.attra.org/attrapub/parasitesheep.html](http://www.attra.org/attrapub/parasitesheep.html)) and also [www.scsrpc.org](http://www.scsrpc.org), the website for the Southern Consortium for Small Ruminant Parasite Control.

Very few anthelmintics are approved for goats, and many parasites have developed resistance to anthelmintics. It is important to minimize the use of anthelmintics in order to delay the development of anthelmintic-resistant parasites. In some cases, drugs will need to be administered in ways that are not FDA approved (extra-label use) in order to manage a parasite problem. This requires a producer to have a working relationship with a veterinarian, preferably one with small ruminant experience.

In many areas, however, there are few veterinarians who are experienced with small ruminants. It is important to find a veterinarian who is compatible with you and with your management style, and one who is willing to learn about small ruminants. With time and patience, your veterinarian can become competent in the diagnosis and treatment of small ruminants. You may locate a veterinarian who wants to practice on small ruminants by contacting the American Association of Small Ruminant Practitioners at [www.aasrp.org](http://www.aasrp.org) or by calling 334-517-1233.

Your veterinarian can help you set up a vaccination program that will protect your flock or herd from some diseases that are problems in your area. Animals are usually vaccinated at least against enterotoxemia and tetanus.

Purchasing new animals or exhibiting at fairs are two ways of introducing diseases into your flock or herd. Isolation of new animals or of those that have been exposed to animals from other farms is a good way to lessen the risk. While they are isolated, pay special attention to the animals and to their behavior. They should be kept separate from the rest for two to three weeks, ideally, and only released when you are confident they are in good health. There are two crucial questions to address before turning them out: have they been effectively de-wormed, and are their feet in good shape? Fecal egg counts before and after treatment will

help verify that you are not releasing a new population of parasites onto your pastures. Your veterinarian can conduct fecal egg counts, and there are courses that provide instruction on conducting these tests (including Web-based courses, such as the one at [www.luresext.edu/goats/library/fec.html](http://www.luresext.edu/goats/library/fec.html)). Limping may indicate foot rot, which you certainly do not want to spread to your other animals. Examine a limping animal carefully. If it has foot rot, you can try to treat it by trimming, disinfecting, and using copper sulphate or zinc sulphate footbaths. Some individuals will be very difficult to cure, and it would be better to cull them rather than risk spreading the problem.

See **Appendix B** for a list of other diseases to be aware of, and check with your veterinarian to learn which ones are likely to be a problem in your area. To learn more about diseases that affect small ruminants, you may want to explore some of the resources listed at the end of this document and contact your veterinarian.

Selecting animals that have proven to be healthy, hardy, resistant to parasites, docile, and good mothers is a sustainable way of building a herd or flock that does not require much veterinary attention. Some breeds are considered more resistant to disease, and some individuals within a breed, herd, or flock will show greater resistance. Encourage this hardiness in your flock or herd by culling the problem animals.

For organic producers, there are a few important differences in health care. You must, of course, provide good nutrition and good living conditions, and you also should give appropriate vaccinations as part of preventative care. You must have a plan to foster good health, including raising hardy animals that are well-adapted to your environment, encouraging biodiversity, using appropriate stocking rates, and providing adequate shelter and 100% organic bedding. You may perform physical alterations (disbudding, docking tails, castration) if they are needed to promote the animal's welfare and if they are done in a way that minimizes pain and stress. Your certifier has the last word on whether you have a strong enough reason and a humane enough method to perform alterations; you must say in your organic system plan what you plan to do, when, how, and why.

When your animals get sick, you must take action to help them get well. This might include good supportive care and extra nutrition, including probiotics and vitamin therapy. It might include homeopathy or herbal remedies or other alternative therapies. But if those means are not sufficient, then conventional methods, such as antibiotics, should be used—but the animal loses organic status and must be marked and later marketed as conventionally raised. You must keep good records to show what health problems each animal had, what means were used to treat the problem, and what the results were. Records will include purchase receipts and labels of all health-care products, documentation of all procedures and treatments, and accurate records of the organic status of each animal.

For organically raised sheep and goats, a significant consideration is that you may not use conventional dewormers, with the slight exception of emergency use of Ivermectin for breeding stock that are not lactating and are not in the last trimester of pregnancy. This is a small window and is usually during a phase when adult stock won't have much trouble with internal parasites. Ivermectin is not effective for many herds and flocks. And it may not be used for lambs or kids, or they lose organic status.

Therefore, organic producers are especially encouraged to use all possible management techniques to prevent illnesses including internal parasitism.

### *a. Observation of Animals*

**The first skill that needs to be developed by a producer is that of careful observation.**

YES NO

1. Do you check your animals every day?
2. Do you know the look and behavior of a healthy animal?
3. How do you recognize an animal that is not healthy? \_\_\_\_\_
4. Have you developed a relationship with a veterinarian who has small ruminant experience? \_\_\_\_\_
5. Do you know what the reportable diseases are for your state? (Contact your state veterinarian.)

YES NO

6. If animals are overly thin, is it due to
- Lack of forage?
  - Lack of quality forage?
  - A health problem, such as internal parasites or pneumonia?
  - Heavy milk production for an extended period of time?
  - Poor teeth?
7. Do you know how to bring your animals into proper condition for the stage of growth, pregnancy, or lactation?
8. Do you routinely check your animals' body condition score?
9. Are most of your animals in proper condition for their stage of production?
10. What is the percentage of death loss in your herd/flock?
- Young animals (between kidding and weaning) \_\_\_\_\_
- Adult animals \_\_\_\_\_
11. Is your death loss acceptable?
12. Do you know the causes of death for most of your losses? What are the main causes on your farm in the past two years? \_\_\_\_\_
13. If the death loss was preventable, have you corrected the situation or management practice that contributed to the loss?
14. Are you in compliance with state laws regarding disposal of dead animals?
15. If it is legal in your state, do you properly compost dead animals?

Make notes here regarding actions to prevent further losses, or areas where you need more information.

---

---

---

**Total yes answers \_\_\_\_\_ Total no answers \_\_\_\_\_**

**Enter these numbers on the Farm Action Plan, pg. 36**

### *b. Parasites*

YES NO

1. Are parasites kept at a level that does not affect animal performance?
- How do you know? \_\_\_\_\_
- How do you monitor the parasite load in your animals? \_\_\_\_\_
2. What practices do you use to reduce parasite problems and avoid the use of anthelmintics?
- Cull animals that get dewormed the most
  - Use cleaner pastures (rest pastures, cut for hay, graze cattle)
  - Graze diverse pastures
  - Reduce stocking rate
  - Avoid grazing pastures shorter than 3 inches
  - Use browse and/or forages with high tannin content
  - Graze cattle or horses with goats or sheep
  - Separate classes of susceptible animals
  - Raise breeds and individuals with resistance to parasites
  - Select rams or bucks with parasite resistance

3. What parasite control program do you use to reduce the use of anthelmintics and manage parasite loads? (Please see [www.scsrpc.org](http://www.scsrpc.org) for information about these techniques.)
- Visual observation to detect animals with parasite problems
  - Use FAMACHA© (see [www.scsrpc.org](http://www.scsrpc.org))
  - Check fecal egg counts prior to and following treatment to monitor loads and check effectiveness of anthelmintics
  - Change class of anthelmintic once resistance is noticed
  - Use herbal dewormers (caution: not all are effective)
  - Strategic deworming just before kidding or lambing
  - Deworm all new animals (and check 7 to 10 days later to be sure there are no eggs in the feces)
  - Use Smart Drenching (see [www.scsrpc.org](http://www.scsrpc.org))
  - Deworm only those animals that need it
  - Cull animals that need frequent deworming (more than three treatments per season for adults)
  - Other: list here \_\_\_\_\_

**Total yes answers \_\_\_\_\_ Total no answers \_\_\_\_\_**

**Enter these numbers on the Farm Action Plan, pg. 36**

### c. Sanitation

Good sanitation is another crucial element of good management. This is of particular importance if your business is producing milk; sanitation as part of the milking routine will result in healthier udders and cleaner milk that tastes better and keeps longer. Animals that are on pasture will usually be clean, but animals that are kept in confinement will need extra care and attention to keep their environment healthful.

During kidding or lambing season, if you use small pens (sometimes called “jugs”) to hold the new mother and her babies for a day or two, it is important to disinfect the newborns’ navels with iodine and keep the pen as clean and well-bedded as possible. If animals are lying in manure or urine-soaked bedding, the chances of mastitis greatly increase. Plenty of bedding can help keep the animals more comfortable and clean. For organic producers, the bedding must be 100% organic.

Good manure-handling practices will also allow for composting of manure, which will be a valuable addition to your fields or garden or may be sold for added income. Information on composting is available from your Cooperative Extension Service. Organic producers are required to have and follow a plan to handle manure in a way that improves the soil and does not harm air, water, or soil quality. Records of manure applications (date and rate) must be kept for five years.

#### General

YES NO

- 1. If you have manure accumulation such as in a confined or semi-confined system, do you have a manure management plan? (If not, contact your NRCS agent to develop a plan.)
- 2. How do you fix muddy areas? \_\_\_\_\_
- 3. Do you have fly control measures in place, if necessary?
- 4. Are your young animals free of coccidiosis?
- 5. Is sanitation generally good?



## Dairy Farmers

YES NO

6. Describe the milking routine, including teat washing and dipping. \_\_\_\_\_  
\_\_\_\_\_  
\_\_\_\_\_
7. What is the average count in your milk for the past six months?  
Somatic Cell Count \_\_\_\_\_  
Total plate count \_\_\_\_\_  
Coliform count \_\_\_\_\_
8. Are these counts acceptable for your market?
9. Is your herd or flock free of mastitis? If not, how do you treat mastitis? (Organic producers may not use antibiotics and retain organic status on the animal, but they must treat if the animal doesn't respond to alternative measures and supportive care.) \_\_\_\_\_  
\_\_\_\_\_
10. What measures do you take to prevent mastitis in your herd or flock?  
\_ Dry treat (not allowed for organic production)  
\_ Teat dip  
\_ Reduce mud  
\_ Improve sanitation  
\_ Milk young animals first  
\_ Milk animals with problems last  
\_ Frequent equipment checks and maintenance  
\_ Gentle hand-milking  
\_ Other \_\_\_\_\_
11. If you raise dairy goats, do you use CAE-prevention strategies?
- In addition to lessening risk of disease in your animals, good sanitation practices are necessary to protect the health of the farmer. Hand washing will help; using rubber gloves or an A.I. sleeve when helping with birthing is also wise. Some diseases carried by sheep or goats will also affect humans, and as always, prevention is better than treatment.**
12. Do you and all your farm workers make a habit of washing hands and arms after handling sheep and goats?
13. Do you use disposable gloves when handling infectious material, such as an aborted fetus or placenta, drainage from abscesses, or sore mouth lesions?
14. Do you have a plan to deal with animal mortalities?
15. Do you know about (and comply with) the laws in your state regarding proper disposal of dead animals?

Total yes answers \_\_\_\_\_ Total no answers \_\_\_\_\_

Enter these numbers on the Farm Action Plan, pg. 36

### d. Predator Control

Although not strictly a “health” problem, one of the causes of loss in a sheep or goat operation may be predation. Coyotes or domestic dogs can devastate a herd or flock if no measures are taken; fencing, penning at night near the house, and guarding the flock or herd using guardian dogs, donkeys, or llamas are all strategies that have proven effective in protecting a flock or herd. (Resources about predator control are listed in **Appendix D, Small Ruminant Resources**.)

YES NO

1. Do you have a predator control program in place?
2. How many animals have you lost to predators in a year? \_\_\_\_\_
3. What measures do you take to protect your animals? (It is best to have more than one.)
- Fence
  - Guardian animals
  - Penning at night
  - Other
4. What types of predators are causing livestock losses in your area? \_\_\_\_\_
5. Is your predator control program effective?

**Total yes answers \_\_\_\_\_ Total no answers \_\_\_\_\_**

**Enter these numbers on the Farm Action Plan, pg. 36**

### *e. Reproduction*

Regular reproduction is one of the keys to profitability and is, therefore, a main goal of a livestock enterprise. It's obvious that reproductive failure will put a dent in the profits. Reproductive inefficiencies will also decrease profits, but they are more difficult to quantify. Getting all of your ewes or does bred and being prepared for lambing or kidding have to be important parts of your enterprise.

Understanding the seasonal mating patterns of sheep and goats will help you manage reproduction and your marketing plans. The gestation length is 145 to 151 days, with sheep averaging close to 148 days and goats near 150 days. Breeding season for most sheep will run from September to early December. Breeding season for goats will run from September to January, with October to December being the peak time for breeding. Some breeds of sheep and goats will be less seasonal and hold the possibility of mating during other seasons of the year. Ovulation rates are higher in October; fewer twins are born when breeding is out of season.

Multiple births (twins and triplets) are common in sheep and goats and are a function of both management and genetics. A minimum of 150% lamb/kid crop weaned is a reasonable goal and will enhance your potential profitability. Do your homework to find the breeds and types that fit best with your management and marketing goals.

YES NO

1. What is your lambing or kidding percentage?  
(Total number of lambs or kids/total of exposed ewes or does x 100) = \_\_\_\_\_ %
2. Does your herd or flock have minimal or no fertility problems?
3. a) What do you do to determine whether or not your animals are fertile? \_\_\_\_\_  
\_\_\_\_\_
- b) What is your system for identifying and culling animals that do not breed and/or kid?  
\_\_\_\_\_
4. Have you done a breeding soundness exam on your ram or buck?
5. Do you know what the body condition of ewes and does should be before breeding?
6. Do you flush your females? (That is, do you provide a higher level of nutrition for two weeks prior to breeding season, continuing for two weeks after breeding, to improve ovulation and conception rates? )
7. Do you isolate your ram or buck from females for a period of time before the breeding season in order to synchronize breeding?
8. Do you provide shade during breeding season?

YES NO

9. Do you use a defined breeding season? Why do you breed/lamb/kid when you do? \_\_\_\_\_  
\_\_\_\_\_
10. When do you begin your breeding season? \_\_\_\_\_
11. How long does breeding season last? \_\_\_\_\_
12. Do you record breeding dates?
13. Do you use a marking system on your ram or buck to monitor activity? (more commonly used with sheep)
14. Do most of your ewes or does settle (conceive) during the first three weeks of your breeding season?
15. Are you satisfied with your lambing or kidding percentage?

Total yes answers \_\_\_\_\_ Total no answers \_\_\_\_\_

Enter these numbers on the Farm Action Plan, pg. 36

**The timing of breeding (and therefore kidding or lambing), type of management, and growth rate of animals all factor into the end product and when you will have products ready to market.**

### Summary

Look back over the year and record the number of losses of baby animals, weaned animals, and adults, and the amount spent on treatment. Aim to have those numbers decrease each year by improving your management, culling animals that do not fit your environment and management, and preventing rather than treating illness. Losses in the past year and reasons \_\_\_\_\_  
\_\_\_\_\_  
\_\_\_\_\_

See **Appendix B** for a chart to summarize the health problems in your herd or flock.

### **3. Breeding and Selection**

If you own a stocker enterprise, you may skip this section; otherwise, breeding and selection is a critical part of your farm and has a very large impact on its sustainability. To evaluate your breeding and selection program, you must first consider the goals of your livestock enterprise and whether you are currently able to meet those goals.

1. What type of enterprise is your focus?  
\_ Meat  
\_ Show  
\_ Breeding stock  
\_ Commercial dairy  
\_ Fiber  
\_ Land management (brush and weed control)  
\_ Hobby
2. Who or what are your intended markets? \_\_\_\_\_  
\_\_\_\_\_

YES NO

3. Considering your enterprise, what are the market requirements for your product? (For example, a meat producer might need to produce 60-pound animals for a specialty market.) \_\_\_\_\_  
\_\_\_\_\_
4. Considering your enterprise and market requirements, what are your goals for your animals? (Produce animals that weigh 60 pounds at 90 days of age, etc.) \_\_\_\_\_  
\_\_\_\_\_
5. Are you currently able to meet your production and economic goals?
6. If not, do you need to change your management or your genetics or both? \_\_\_\_\_
7. Do your animals fit your goals? (For example, are your animals capable of rapid growth? Do the does and ewes milk well? Does your flock provide wool that is consistent in color, length, and quality?)
8. If you are able to meet your current production goals, is it profitable to do so?
9. Consider the overall appearance of your herd or flock and note your impressions here. \_\_\_\_\_  
\_\_\_\_\_
10. Do your animals prosper in your current system?
11. Looking at your whole herd or flock (physically and on paper, by assessing records), do you see individuals that are very different from the rest? (Is your herd/flock uniform, or do you have animals that are superior or inferior to the rest of your animals? Which animals should be retained for breeding?) \_\_\_\_\_  
\_\_\_\_\_  
\_\_\_\_\_
12. What are your criteria for selection (or retention) of breeding animals? (Check the appropriate categories, and list your specific standards for each category.)
- \_\_ Productivity ( a combination of several traits) \_\_\_\_\_
- \_\_ Fertility \_\_\_\_\_
- \_\_ Hardiness \_\_\_\_\_
- \_\_ Milk production \_\_\_\_\_
- \_\_ Disposition \_\_\_\_\_
- \_\_ Mothering ability \_\_\_\_\_
- \_\_ Body type \_\_\_\_\_
- \_\_ Growth rate \_\_\_\_\_
- \_\_ Ability to thrive on forage alone \_\_\_\_\_
- \_\_ Internal parasite resistance \_\_\_\_\_
- \_\_ Fiber quality \_\_\_\_\_
- \_\_ Other: \_\_\_\_\_
13. Do you have objective ways to evaluate the quality of your livestock and their products?
- \_\_ Milk quality testing
- \_\_ Milk production testing
- \_\_ Meat tests—grades, yield, tenderness, juiciness, taste, and quality
- \_\_ Weight records
- \_\_ Fiber testing—fineness, strength, yield
- \_\_ Fiber grading

YES NO

14. Are you satisfied with the performance of your current breeding animals?
15. List here any areas that need particular improvement. Ranking the concerns in order of importance may help as you decide which traits are most important. \_\_\_\_\_  
\_\_\_\_\_  
\_\_\_\_\_
16. Do you keep and review adequate records so that you can decide which animals to keep and which to cull?

### Areas to Improve

17. List here anything regarding your livestock that you would like to improve or upgrade.  
\_\_\_\_\_  
\_\_\_\_\_

**Total yes answers \_\_\_\_\_ Total no answers \_\_\_\_\_**  
**Enter these numbers on the Farm Action Plan, pg. 36**

## C. Marketing

Making a living on the farm depends on three essentials:

- 1) producing something of value
- 2) selling it for a profit
- 3) selling enough of it.

The preceding sections focused more on the first part of the equation, production. This section is meant to trigger thinking about selling what your farm produces. For example, a sheep farmer produces lamb meat, replacement stock, skins, wool, manure or compost, and perhaps provides weed control. Lambs can be sold as breeding stock, show lambs, feeder lambs, fat lambs, or as freezer lambs. If USDA inspected, the meat can be sold as cuts to individuals, stores, or restaurants. Wool could be processed into yarn, roving, batts, or further processed into woven, knitted, felted, or crocheted items. Farmers may choose to sell what they are raising for “commodity” prices, seek out a niche market, or use a combination of strategies. For example, sheep farmers can sell freezer lambs directly to customers and sell extra lambs at a sale barn. They may choose to hold back a few fleeces for hand spinners, a few more for further processing into yarn or woven blankets, sell some wool to a wool cooperative, and use the dirty parts of all fleeces as mulch in a garden or orchard.

The possibilities are limited only by the producer’s imagination, time, and energy. Time and energy spent in marketing tends to have a large financial return. For example, selling two of the best fleeces to hand spinners may net more income than selling 20 fleeces to the wool cooperative, and with very little effort.

Having multiple items to sell and multiple markets for those items can strengthen the economic health of the farm. However, each additional item and market will require additional time and effort.

Making effective use of the Internet, including free directories such as [www.localharvest.org](http://www.localharvest.org) and other tools, will improve the odds of a customer finding you and your farm. There are many other ways to increase visibility and attract more buyers.

Marketing is the main part of your business and deserves more attention than this document can give. One book that may be helpful is *Marketing Farm Products: And How to Thrive Beyond the Sidewalk*, by Ellie Winslow (see **Appendix D: Small Ruminant Resources**). This book focuses on the four “P’s” of marketing: product, price, place, and promotion. It will help you recognize many ways of finding and pleasing customers, increasing sales, and improving profitability by paying attention to this critical area.

See the business planning resources listed in the **Small Ruminant Resources** for other books and Web sites that will be useful as you learn.

YES NO

1. What is it that you produce? List all of the products that you could produce, even if you are not currently selling them. (Don't forget the wool.) \_\_\_\_\_  
\_\_\_\_\_
2. What product(s) do you sell? \_\_\_\_\_
- Considering all the products you do or could produce on your farm, are you selling as much of that variety as you wish to?
3. How do you sell your product(s)? List the product to the right.  
\_ Direct market (such as farmers' market, or to restaurants) \_\_\_\_\_  
\_ On-farm sales \_\_\_\_\_  
\_ Contract \_\_\_\_\_  
\_ Wool pool \_\_\_\_\_  
\_ Spinners guild \_\_\_\_\_  
\_ Niche users—craftspeople \_\_\_\_\_  
\_ Sale barn \_\_\_\_\_  
\_ Web site \_\_\_\_\_  
\_ Other \_\_\_\_\_
4. Are you satisfied with the markets you are currently using?
5. Have you identified other existing marketing channels/options that might expand your opportunities? \_\_\_\_\_
6. Do you have a plan for entering new marketing channels?
7. Is the market increasing?
8. Are the markets for your products stable throughout the year?
9. Are you selling your products for the best possible prices?
10. Is the price sufficient for you to make a profit on the enterprise?
11. Are you timing production to get the best price?  
\_ Freshening does or ewes to accommodate your milk market  
\_ Kidding or lambing to accommodate your meat market  
\_ Shearing at optimal time to obtain best quality fleece
12. Are you able to produce at the right time for your customers? (for example, to match ethnic holiday demands for meat)
13. Are your products of consistently high quality?  
\_ Uncontaminated milk with consistently good flavor  
\_ High yielding carcasses, tender meat  
\_ Clean, strong fleeces, free of vegetable matter and properly skirted  
\_ (list your product and quality attributes) \_\_\_\_\_  
\_\_\_\_\_
14. Are you in compliance with all regulations?
15. Do you have a processor for your raw products? (milk, meat, fiber, hides)
16. What other possibilities can you think of for selling your product(s)? (Consider value-added products, new outlets, new promotion ideas, etc.) \_\_\_\_\_  
\_\_\_\_\_  
\_\_\_\_\_
17. Is there one person on your farm who takes responsibility for the marketing?

YES NO

18. How much time is currently spent on marketing activities, such as advertising, contacting buyers, checking prices, hauling products to market, or other related activities?

---

---

19. Is the time currently spent on marketing having satisfactory results?

20. Is the time currently spent on marketing affordable? (Think about results for the time spent, physical energy, fuel, and other duties of the marketing person.)

Note here any improvements in marketing or processing that you can think of and note those on the Farm Action Plan as well (page 36)

---

---

---

---

**Total yes answers \_\_\_\_\_ Total no answers \_\_\_\_\_**

**Enter these numbers on the Farm Action Plan, pg. 36**

## D. Records

Businesses must have records to comply with laws, file accurate tax returns, and to have reliable data for making assessments and determining profitability. Farm businesses with livestock need to have records about individual animals in order to make good selection decisions. Organic livestock producers must have and keep (for five years) extensive records to document land use, pasture rotation, anything applied to the land or used for health care in the animals, feed rations (and tags), origin of livestock, organic certificates for all feed used and stock bought, breeding, health, and sales records, and more. These records must be organized well enough that an inspector making his yearly visit can determine where all feed fed on the farm was grown or purchased, what manure applications were made (date and rate), what the length of the grazing season was, and how much of the sheep or goats' ration was forages during the grazing season—and more. Soil tests, forage analyses, maps, water tests, and other evidence may be needed to show that farm practices are improving the soil and not compromising water or soil quality. It is not for the faint of heart.

However, keeping such extensive records can help the producer learn much more than simple observation can teach. Regularly reviewing soil tests will help the producer understand the impact his or her management is having on the land. Examining financial records closely can show what parts of the farm are paying their way and what parts need to be improved or dropped. Using livestock records as a basis for decision-making can improve a herd or flock dramatically.

Consider what records are needed for your farm business and whether you are using those records as effectively as you could.

1. What types of records do you currently keep? (Check all that apply.)

Premises ID \_\_\_\_\_

Permanent Individual Identification (other than premises ID) \_\_\_\_\_

Health \_\_\_\_\_

Breeding \_\_\_\_\_

Production (milk, offspring born and raised) \_\_\_\_\_

Financial \_\_\_\_\_

Labor \_\_\_\_\_

YES NO

- Growth rates \_\_\_\_\_
- Sale records of your main products \_\_\_\_\_
- Cull or death records \_\_\_\_\_
- Pasture or forage records—rotational grazing \_\_\_\_\_
- Whole farm plans \_\_\_\_\_
- FAMACHA® scores and fecal egg counts \_\_\_\_\_
- Other \_\_\_\_\_

- 2. Are records recorded and updated frequently?
- 3. Do you process your records, calculate averages, and/or identify inferior animals?
- 4. Is there a designated person who updates and monitors records?
- 5. Are your record systems adequate? (paper or software)
- 6. Do you use records for management decisions and future planning?
- 7. Do your records show that you have improved your farm over time?
- 8. When was the last time you reviewed your records? Write the approximate date beside the type of record listed in question #1 above.
- 9. Is the time spent on records sufficient?

- 10. For organic farmers: are your records sufficient to prove compliance with the National Organic Program regulation and your Organic System Plan (OSP)?

**Total yes answers \_\_\_\_\_ Total no answers \_\_\_\_\_**

**Enter these numbers on the Farm Action Plan, pg. 36**

## E. Economics

How do you measure the economic health of your enterprise, farm, and household? Do you know what it costs you to raise a lamb/kid to market weight? Maintain a ewe/doe over the winter? Produce milk, meat, or fiber? By careful cost accounting, you can determine the break-even prices for your products.

Besides “out of pocket” costs, you need to account for family labor. There is an “opportunity cost” associated with any use of your time—that is, taking advantage of one opportunity prevents you from taking advantage of another — and to decide whether an enterprise is truly profitable, you must be honest about the time spent producing your product. On the other hand, a sustainable sheep or goat farm may make excellent use of labor that would not otherwise be employed—children, retired persons, or farmers who keep their regular job and raise sheep or goats in their “off” hours. A few things to consider are profitability, cash flow, debt load, risk, financing expansion, taxes, reducing cost of production, and increasing return by some further processing.

This section is to help you identify gaps in your knowledge of actual costs of production and good financial management practices. Keep in mind your farm goals, family interests, and the production and marketing aspects you’ve already considered, and see whether you can recognize opportunities to improve the financial picture.

Many of the questions asked in this section will be answered when you work on Schedule F for your federal tax return. You might want to refer to the past two or three years when answering these questions for the first time, and aim to make next year’s numbers an improvement on the past’s. It is helpful to work this section at the end of each year or at tax time. Looking at feed costs from the start of one grazing season to the start of the next is very useful as well.



YES NO

1. Is your sheep or goat operation currently profitable? If yes, what is the annual net return per ewe or doe? \$ \_\_\_\_\_
2. Have you developed an enterprise budget for your goat or sheep enterprise?
3. Have you identified all areas of your enterprise in which you spend money? (Note approximate yearly amounts.)
- |                               |          |
|-------------------------------|----------|
| Feed                          | \$ _____ |
| Hay                           | \$ _____ |
| Health care                   | \$ _____ |
| Deworming                     | \$ _____ |
| Vet bills                     | \$ _____ |
| Replacement/expansion animals | \$ _____ |
| Fencing                       | \$ _____ |
| Equipment                     | \$ _____ |
| Fuel                          | \$ _____ |
| Labor                         | \$ _____ |
| Hired services                |          |
| Shearing                      | \$ _____ |
| Tractor work                  | \$ _____ |
| Custom work                   | \$ _____ |
| Marketing expenses            |          |
| Processing                    | \$ _____ |
| Advertising                   | \$ _____ |
| Delivery/distribution         | \$ _____ |
| Predator control              | \$ _____ |
| Land                          | \$ _____ |
| Taxes                         | \$ _____ |
| Supplies                      | \$ _____ |
4. Have you performed a break-even analysis?
5. What does it cost per animal to feed your breeding sheep or goats for a year (total hay and grain costs)? \$\_\_\_\_\_ (If the number of breeding animals changed during the year, you may arrive at costs for portions of the year.)  
What are some ways to reduce that feed cost? \_\_\_\_\_
6. Can you make a good profit after feed and other costs are paid?
7. Do you know what it costs to raise a lamb or kid to market weight? \$\_\_\_\_\_
8. Do you know what it costs to put on a pound of gain or to produce a pound of milk? \$ \_\_\_\_\_
9. What are your three biggest expenses? (Refer to question #3) \_\_\_\_\_  
\_\_\_\_\_  
\_\_\_\_\_
10. Can you identify ways to reduce your biggest expenses? List some here. \_\_\_\_\_  
\_\_\_\_\_  
\_\_\_\_\_  
\_\_\_\_\_

You have looked at some cost categories and have a better idea of your production and marketing expenses. Now examine your income from your enterprise.

11. What products do you get income from? (Note estimated number of animals and income for each category.)

Live animals

Breeding stock	_____	\$ _____
Slaughter stock	_____	\$ _____
Weaned animals	_____	\$ _____
Show stock	_____	\$ _____

Meat

Cuts	_____	\$ _____
Whole processed animals	_____	\$ _____
Value-added products, such as jerky or sausage	_____	\$ _____

Milk

Fluid milk	_____	\$ _____
Value-added dairy products	_____	\$ _____

Fleece

Raw fleece	_____	\$ _____
Value-added fiber products	_____	\$ _____

Services

Grazing services	_____	\$ _____
Buck/ram rental	_____	\$ _____
Agritourism	_____	\$ _____
Educational classes (spinning, for example)	_____	\$ _____

Manure

	_____	\$ _____
--	-------	----------

YES NO

- 12. Do you set the price on products you sell?
- 13. Are you satisfied with the prices you receive in your current markets?  
If not, how might you improve the price you receive? \_\_\_\_\_
- 14. Do you have enough product(s) to sell to make a profit?
- 15. Are your ewes or does productive enough that you can sell their progeny for a profit after all costs are paid?
- 16. If your main product is meat, how many kids or lambs do you need to sell annually per doe or ewe to cover expenses? \_\_\_\_\_
- 17. Is your enterprise the right size for your farm? (Sometimes expanding your operation may improve profitability and, conversely, sometimes downsizing helps improve profitability.)
- 18. Could you increase profitability by any of the following: (Check all that are possible.)
  - Changing the way that you market
  - Changing the mix of products you sell (changing emphasis)
  - Adding value to products through increased processing (wool to yarn, lamb to packages of chops, milk to cheese)
  - Reducing production costs by grazing more and/or by cutting back on inputs (such as grain)
  - Diversifying with a complementary enterprise such as hunting, pastured poultry, hogs, stocker cattle, or other

- Selling all the products possible
- Cooperating with other producers (to improve prices, gain access to new markets, cut marketing costs, diversify products offered)
- Reducing wastes (grain, hay, etc.)
- Reducing labor costs
- Increasing production through improved genetics or management
- Improving health care, including parasite management
- Raising prices (if you sell direct) or selling at favorable times
- Changing the time of year (or month) of lambing or kidding
- Improving pasture management by using more cross-fencing
- Taking advantage of cost-share and other government programs (See your NRCS agent.)
- Other \_\_\_\_\_

**Labor is a cost, although when you use family labor, it is less apparent.**

**YES NO**

- 19. Do you know how much time is invested in each of your products?
- 20. If you are selling a processed product, are you being compensated for the extra time you have invested?
- 21. Does the daily routine run smoothly and easily? If not, what can be changed to streamline the work? \_\_\_\_\_
- 22. Think of the yearly cycle of tasks. Are these tasks accomplished as efficiently as possible? If not, what should be changed? \_\_\_\_\_
- 23. If you hired outside labor in the past year, how much did it cost? \$ \_\_\_\_\_
- 24. Was the expense a justified cost?
- 25. Do you have access to an adequate farm labor supply?
- 26. Are you able to effectively manage and compensate workers (including hired and family labor)?
- 27. Does your current labor force have all the skills necessary to effectively operate your farm or value-added business?
- 28. Do you have access to adequate training opportunities?
- 29. Do you know the legal regulations regarding hired labor?
- 30. Are your labor records accurate and up to date?
- 31. Are you a good boss?

**Taxes**

- 32. Do you know the IRS guidelines for farm businesses?
- 33. Are you keeping thorough records of all expenses, including mileage for farm vehicles?
- 34. Do you keep all pertinent invoices and other documentation of expenses and receipts?
- 35. Are your financial records well organized?
- 36. Do you have a good farm tax accountant?

**Legal** (See National Ag Law Center, [www.nationalaglawcenter.org](http://www.nationalaglawcenter.org))

- 37. Do you have a legal consultant or representative?

YES NO

38. Are you aware of the various legal entities and areas of potential legal risk?  
Consider how you can protect yourself in these areas.
- General personal and business liability
  - Health codes
  - Zoning regulations
  - Labor laws
  - Land and other large purchases
  - Environmental regulations
  - Food safety
  - Processing and marketing regulations

### Equipment

39. Are all your equipment expenses justifiable?
40. Do you do regular maintenance to keep equipment in good repair?
41. Is your current equipment adequate for your farm?
42. If not, have you budgeted for new or replacement equipment?
43. Do you have excess or unused equipment that should be sold?
44. Do you have the skills necessary to maintain equipment (or know someone reliable and affordable)?

### Farm Financial Analysis

Debt is a tool that can be helpful or harmful, depending on how you manage it. With wise use of debt, you can expand a profitable enterprise and make purchases when the time is right. However, excessive debt can cripple a business. It is important to understand finances beyond what may be required for the Schedule F on your 1040 form. With a small investment of time, you can generate meaningful financial information, improve your management skills, and provide more detail about the status of your farm. Improved financial information may not be meaningful the first year, but the power of financial information comes over time. Developing a history to refer to gives you crucial information to guide future decisions.

Understanding the 16 standard farm financial ratios and measurements for farms can help you see opportunities for improvements in your business. For detailed, technical information about farm financial indicators and ratios, see the “Farm Financial Standards Council Guidelines” at [www.ffsc.org](http://www.ffsc.org). Another useful site for farm financial information and analysis is [www.agecon.purdue.edu/extension/programs/fbm21/Ec712entry.htm](http://www.agecon.purdue.edu/extension/programs/fbm21/Ec712entry.htm). This information from Purdue Extension offers worksheets and concise, user-friendly instructions and explanations. Using these and similar tools to understand the financial workings of your farm is crucial to sustainability.

The business planning resources in the **Resource List** will be good references as you learn more about managing the finances of your farm.

### Debt Load

YES NO

45. How much was spent on interest payments for the farm last year? \$ \_\_\_\_\_
46. Do you have a good standing with your lender (bank, Farm Credit, etc.)?
47. Is the farm debt manageable?
48. Is the financial picture improving?

Total yes answers \_\_\_\_\_ Total no answers \_\_\_\_\_

Enter these numbers on the Farm Action Plan, pg. 36

## F. Quality of Life

No farm is sustainable if the farmers are not enjoying their work. Sometimes rearranging the workload can improve the satisfaction of everyone concerned, as well as improving the productivity of the farm. This is because those who are well suited to a task will pay more attention to it, be more efficient, and take more pride and care in their work. Forming relationships with your local 4-H clubs and FFA chapters may be beneficial. It is a way to introduce young people to small ruminant production, and you can make contacts with youths who may be willing to help on your farm. They may also be potential customers for your replacement or show stock.

The following questions are to help determine the best division of work for your farm.

YES NO

1. Who does most of the management of the sheep or goat enterprise? \_\_\_\_\_
2. What other responsibilities does this person have? \_\_\_\_\_  
\_\_\_\_\_
3. What times of the year demand the most labor? \_\_\_\_\_  
\_\_\_\_\_
4. Is there enough labor available at all times of the year? If not, can you think of a way to relieve the pressure? \_\_\_\_\_  
\_\_\_\_\_
5. What would make the enterprise or the whole farm more labor-efficient?  
\_\_\_\_\_  
\_\_\_\_\_
6. Do the persons involved in the care of the animals like to work with them?
7. List the strengths of each person involved in the farm work. (for example, "John is great with machinery and grazing management, Ken likes to build fence, Jim knows and loves all the animals.") \_\_\_\_\_  
\_\_\_\_\_  
\_\_\_\_\_
8. Are the people assigned to the tasks best suited for the job?
9. Can all tasks be performed safely?
10. Have each person involved in the farm write down his or her favorite tasks or season (for example, lambing season) and also his or her least favorite (perhaps cleaning out the barn). In some cases, a shift in responsibilities may be called for so that people can work in areas they enjoy. Fitting the person to the work is one way to improve morale and efficiency, and may ensure better work and, therefore, a better-kept farm.  
Favorite Job: \_\_\_\_\_  
\_\_\_\_\_  
\_\_\_\_\_  
Most Disliked Job: \_\_\_\_\_  
\_\_\_\_\_  
\_\_\_\_\_  
Notes on possible adjustments to job assignments: \_\_\_\_\_  
\_\_\_\_\_  
\_\_\_\_\_
11. If your minor children are part of your labor force, consider whether their responsibilities should be increased or decreased. How could this influence your operation in the next five or ten years? \_\_\_\_\_  
\_\_\_\_\_

- 12. Do you know the farm labor laws in your state?
- 13. Do you have a farm liability policy? (Talk with your insurance agent to be sure.)
- 14. Do you have a plan for vacation care or other necessary absences? \_\_\_\_\_  
 \_\_\_\_\_  
 \_\_\_\_\_
- 15. List at least one teenager or college student who could be hired to help with physically demanding work such as foot trimming, manure handling, or shearing. \_\_\_\_\_  
 \_\_\_\_\_
- 16. List at least one teenager or college student who could be hired to help at peak labor times such as lambing or kidding. \_\_\_\_\_  
 \_\_\_\_\_
- 17. Does your work force (family and hired labor) feel free to contribute ideas about the farm?
- 18. Does your work force communicate well with you and with each other?
- 19. Is the main manager open to ideas about changes and innovations?
- 20. Does everyone in the work force have the opportunity for time off?

**Total yes answers \_\_\_\_\_ Total no answers \_\_\_\_\_**  
**Enter these numbers on the Farm Action Plan, pg. 36**

## G. Areas to Improve

List here any aspects of husbandry, forages, marketing, records, or enjoyment of life that need to be improved. Which of these are most important in increasing the sustainability of your farm? What additional information do you need to make improvements?

\_\_\_\_\_

\_\_\_\_\_

*See the Farm Action Plan, page 36, for help in prioritizing and in finding resources.*

## V. Systems Management

### A. Timing

By changing the time of lambing or kidding, you change the demands on the system. Moving the lambing or kidding date one month later (say, from February to March) will reduce the amount of purchased feed needed and change the stocking rate for the whole summer, but it may also result in a lower price received for market stock. All these factors, and more, must be weighed in order to make a decision about the best time to have animals born.

1. How do you decide when to begin lambing or kidding? (Check all that apply.)
  - Weather at time of lambing or kidding
  - Pasture availability
  - Time of specialty markets
  - Expected price at marketing time
  - Cost and/or availability of hay and grain
  - Animal growth needed for target market-weight
  - Minimizing internal parasite problems for young stock
  - Buck or ram decides

2. List the approximate dates when you typically do the following:

- a) Increase nutrition prior to breeding; flushing (not necessary unless animals are thin; improves ovulation if they are thin) \_\_\_\_\_
- b) Begin breeding \_\_\_\_\_
- c) Increase nutrition prior to lambing or kidding \_\_\_\_\_
- d) Begin lambing or kidding \_\_\_\_\_
- e) Wean stock \_\_\_\_\_
- f) Sell young stock \_\_\_\_\_
- g) Reseed pastures \_\_\_\_\_
- h) Fertilize \_\_\_\_\_
- i) Lime pastures \_\_\_\_\_

Here is a graph showing the energy requirements for a ewe throughout the year; the pattern is the same for a doe. The bar on the left is pounds of dry matter, from the National Research Council tables. The ewe's or doe's requirements increase dramatically just before lambing or kidding, and continue through peak lactation; then at weaning, the nutritional demands are low for the female (but then it's time to have your best forages for the weaned lambs and kids). Note the effect of twins on the mother; this is why some producers separate into groups and supply extra feed to the ewes or does raising twins.

**Energy Requirements (154 pound ewe)**

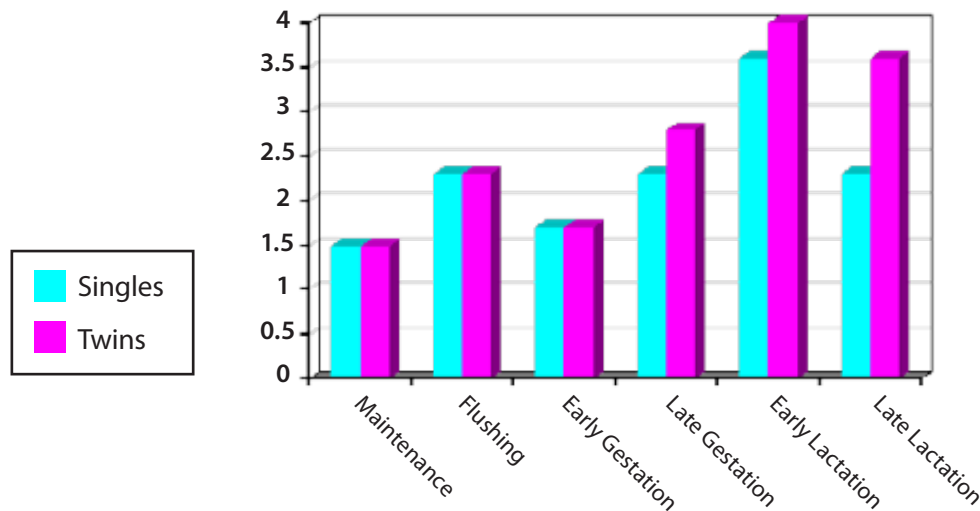

Source: Kott, Rodney. 2006. *Montana Farm Flock Sheep Production Handbook*. Animal and Range Sciences Extension Service. Montana State University. Nutrition: Part 1. [www.animalrangeextension.montana.edu/articles/sheep/Flock%20Handbook/Nutrition-1.htm](http://www.animalrangeextension.montana.edu/articles/sheep/Flock%20Handbook/Nutrition-1.htm).

Combining these guidelines with the previous information, you may work out a rough calendar showing the times of greatest feed requirements. This calendar can then be used in conjunction with forage availability data to work out changes to improve the “match” between forage availability and animal needs.

Current Plan												
	Jan	Feb	Mar	Apr	May	June	July	Aug	Sept	Oct	Nov	Dec
FN												
FA												
\$ In												
\$ Out												
KEY: FN= forage needed (consider number of mature animals, number of young, stage of production) FA= forage availability (high, medium, low) \$ In= months when animals are sold; may estimate receipts \$ Out= months when feed must be purchased; may estimate cost												

A quick way to get a picture of this is to use colors and shade the FN boxes during the months when you NEED the most forage; then shade the FA boxes during the months when you HAVE the most forage. Then think through how this works out. Do you make hay during months of high forage availability? Is that enough to feed your animals all winter? How much money do you need to spend on supplemental feed with your current system? How much money do you make on products sold with your current system? Do you consider when to reseed and fertilize in order to get timely forage production?

Now, imagine changing your lambing or kidding season by moving it six or eight weeks later (or earlier), and do the same exercise. Which season fits your forage resources better? Which one results in the higher expected profitability?

Potential Plan												
	Jan	Feb	Mar	Apr	May	June	July	Aug	Sept	Oct	Nov	Dec
FN												
FA												
\$ In												
\$ Out												

Figure the approximate cost of supplemental feed and note which months you'll need to purchase feed. Then figure the price you expect to get per pound of milk or meat, multiplied by the number of pounds you expect to sell, and write in those figures for the months when you plan to sell products. Time spent in thinking through various scenarios of timing and marketing may be the most profitable time you spend in managing your sheep or goat farm.

## B. Coordinating Enterprises

What other enterprises do you run on your farm? Sheep and goats can fit well with many other enterprises, including beef cattle, field crops, and vegetables. Diverse enterprises can improve cash flow and stability, make better use of land and labor, and increase profitability. The trick is to keep the farm manageable and labor costs in line with how much each enterprise contributes to farm income. That is, more profitable enterprises should get more of the manager's attention and time. Allowing a minor enterprise to detract from a major one can reduce farm sustainability, unless the minor one has the potential to return enough profit to pay for the labor. Even if sheep or goats are the sole enterprise, you may diversify your farm by selling more products (especially value-added items) from the sheep or goats. Use these questions to explore your whole farm operation while planning the future use of your resources.



YES NO

- 1. Do your enterprises and management style match your stated goals? (see pg. 7)
- 2. What enterprises are you currently managing? \_\_\_\_\_
- 3. What products are sold from your farm? \_\_\_\_\_  
\_\_\_\_\_
- 4. Checking your financial records, which enterprise or which products have proved most profitable in the past? \_\_\_\_\_
- 5. Which have the most potential for growth? \_\_\_\_\_
- 6. Which are most demanding in terms of labor? \_\_\_\_\_
- 7. Which require the most capital throughout the year? \_\_\_\_\_  
\_\_\_\_\_
- 8. Which require the most land? \_\_\_\_\_
- 9. Considering all the above, which enterprise do you feel should get the most management attention? \_\_\_\_\_
- 10. Which enterprises are most enjoyable? \_\_\_\_\_

What benefits does each of your enterprises bring to the farm as a whole? (Think about forage use, one enterprise using waste from another, better use of labor, marketing advantages, cash flow, balancing risks, and any other ways in which each enterprise complements the farm.) \_\_\_\_\_  
\_\_\_\_\_  
\_\_\_\_\_  
\_\_\_\_\_

\*\* Note here any ideas about improvements to the whole farm, particularly about ways to make better use of the farm resources. \_\_\_\_\_  
\_\_\_\_\_  
\_\_\_\_\_  
\_\_\_\_\_



## VI. Conclusion

After answering the preceding questions, you should have a good idea of improvements that you need to make to be more sustainable. Use the Farm Action Plan on the following page to tabulate the number of “yes” and “no” answers in each section and then to rank the categories by priority. Which area needs attention first? Another way to think of this is to ask, “what is the ‘weak link’ in our farm?” A large number of “no” answers in a particular section should point to the weak link for you.

However, the questions are not weighted; some “no” answers are of relatively minor importance, and some open-ended questions may have pointed to areas of greater concern. Therefore, the Action Ranking column is for prioritizing. You may want to highlight several lines with a large proportion of “no” answers, then decide which is the weakest link, and number it “1.” The Action Plan column in the table provides a small space for notes or to write the first step in improving a troublesome area. It is useful to transfer plans to your calendar, with deadlines, to encourage action in solving problems.

Remember the SMART acronym for goals: make them Specific, Measurable, Attainable, Realistic, and Timely.

Finally, the Information Resources column will list a few numbers corresponding to resources listed in **Appendix D**. These resources may be helpful as you take steps toward improving the sustainability of your farm. You may call the ATTRA toll-free number, 800-346-9140, if you need further assistance.



This document was developed in 2004 by Linda Coffey, technical specialist with the National Center for Appropriate Technology's National Sustainable Agriculture Information Service, and Jana Reynolds and Margo Hale, interns with the National Center for Appropriate Technology. The project was funded by a Southern SARE-PDP grant. Thanks to all of the contributors: NCAT technical specialists Alice Beetz, Tim Johnson, Dr. Ron Morrow, and Dr. Ann Wells; sheep and goat producers Linc Abney, Jack Black, Ken Hargis, Jim Morgan, Debbie Taylor, and Delane and Linda Wright; representatives of USDA - NRCS Rhonda Foster and Claire Whiteside; Extension agents Johnny Gunsaulis, Carey Wall, and Dr. Jodie Pennington of the University of Arkansas Cooperative Extension Service, and Steve Morgan of the University of Georgia Cooperative Extension Service; researchers Dr. Ken Coffey of the University of Arkansas, and Dr. Will R. Getz, Fort Valley State University, Georgia; Dr. Steve Hart, Langston University, Oklahoma; Dr. Dianne Hellwig, Berea College, Kentucky; and Dr. Jean-Marie Luginbuhl, North Carolina State University.

Updated 2010 thanks to a grant from Southern SARE-PDP.

## Farm Action Plan

- 1.) Count and record the number of “yes” and “no” answers in each category.
- 2.) Rank the areas that need improvement in the order of importance (1 being most important).
- 3.) See numbered references in the Resources section for information. The resources listed are suggested places to start to find information on these topics. Please call ATTRA at 800-346-9140 if you need further assistance and to request ATTRA publications.

Subject Area	Totals		Action Ranking	Action Plan	Information Resources
	Yes	No			
A. Forages					3, 67-94
1. Inventory					8, 48, 76, 80,81,86,87
2. Utilization					3, 48, 58, 68-79, 82-94
B. Livestock					1-66 for general resources
1. Nutrition					8, 48, 54, 50, 74-76, 12, 13, 14, 20, 26, 33-35
2. Health					8, 48, 32, 54, 65, 58, 95-119
a. observation					1-3, 13-15, 30, 33-39, 58
b. parasites					95-97, 114, 118
c. sanitation					48, 106
d. predator control					98, 103, 104, 8, 48
e. reproduction					8, 14, 17, 42, 48, 53, 32, 65
3. Breeding & Selection					1, 8, 56, 3, 14, 20, 26, 27, 32-48, 52-53, 57
C. Marketing					120-138, 3, 8, 13, 14, 51, 126, 48, 57
D. Records					3, 8, 58, 48, 126-128, 135
E. Economics					3, 8, 48, 126-138
F. Quality of Life					2, 3, 126-128, 132-138

## Appendix A: About Organic Production

---

If you are interested in alternative production and marketing methods, you may want to consider organic. “Organic” means, among other things, raising crops or livestock in a way that builds the soil and enhances biodiversity and ecological balance. The term “organic” may not be used except under a production system that meets all the requirements of the National Organic Program Regulations, as defined in 7 CFR Part 205 (see [www.ams.usda.gov/AMSv1.0/nop](http://www.ams.usda.gov/AMSv1.0/nop)).

Some producers choose to farm organically because they believe in the principles of organic agriculture, that organic systems build the health of soils, plants, animals, and people. Others do so because they want to sell products for a premium price to people who support organic principles and believe organic food is better for their health.

Depending on your production and marketing methods and customers, it may be to your advantage to raise and sell organic kids or lamb or wool. This section highlights what is involved in producing goats or sheep organically, and it will help you decide whether transitioning to organic is worthwhile for your operation.

What are the basic requirements of organic certification? (This is not a complete list.)

- Feed 100% certified organic feed (including pasture).
- Animals must graze on pasture at least 120 days per year, and animals must have a minimum of 30% dry matter intake from grazing pasture during the grazing season.
- Use of most synthetic medicines and/or hormones is prohibited (see the National List for materials and the purposes for which they may be used).
- Maintain organic stock under organic management from at least the last trimester before birth (i.e., does and ewes must be managed organically for more than 50 days before organic kids and lambs are born).
- Meat must be processed in a certified organic facility and must not be irradiated.

For more information about the requirements for organic livestock production, see ATTRA’s *Organic Standards for Livestock Production: Highlights of the USDA’s National Organic Program Regulations* (summary of relevant verbatim standards) and *NCAT’s Organic Livestock Workbook* (longer workbook format to guide the producer in looking at all components of a production system as they relate to organic standards and practices).

There are also important record-keeping requirements and certification tasks, including the following.

- An organic system (farm) plan approved by a certifying agent
- Up-to-date farm records for at least five years
- Annual inspection of the farm, including records and premises

For some farms, current production practices are already very close to organic standards. Some farms keep extensive records. But for most, changes will be necessary in both production and record-keeping in order to comply with organic regulations. Will those changes be worth it? Consider the following questions.

- What price do you currently receive for your product?
- Is there local demand for organic products? (If not, you will need to develop a local market or develop one at a distance, and ship your product. Remember, market development costs time, energy, and money.)
- What price could you receive for organic goat meat, lamb, or wool? (Check the Internet for some idea of prices being asked.)
- What do you currently pay for hay or grain to supplement your animals?
- What would you have to pay for organic hay or grain? How dependable is the local supply? Can you offset the increase in the price for organic feed with sales of certified organic animals or products? (Remember, using homegrown feeds, especially pasture, will help greatly.)
- How important is organic certification to your customers? Is it sufficient for them to know you as the producer and understand that you use humane and sustainable practices, or do they need to see verification of organic standards?

Now for the next hurdle: if you are selling meat,

- Is there a certified organic processor in your area? This is necessary if you are selling organic meat.

- If there is not currently an organic processor, can you persuade a local processor to do the paperwork and follow the regulations?
- What extra processing costs will be charged for organic processing?

For information about organic meat processing, see [www.extension.org/pages/Certified\\_organic](http://www.extension.org/pages/Certified_organic) and [www.mosesorganic.org/attachments/broadcaster/livestock14.6meatprocess.html](http://www.mosesorganic.org/attachments/broadcaster/livestock14.6meatprocess.html).

If you are selling a live animal,

- Who is your buyer? It's best to have more than one option.
- What is the demand? How many animals can you sell a year, and is it a steady market?

If production costs will be feasible and the market is not a problem, then consider whether you can you raise your animals under organic health management practices.

Organic health care is based on prevention of illness through good management.

- Animals adapted to the environment
- Appropriate vaccinations
- Good nutrition
- Low-stress handling
- Good sanitation
- Access to well-managed pasture, fresh air, and sunshine
- Low stocking rates
- Adequate shelter
- Good preventive care (regular foot trimming, for example)

All the above practices should be followed by producers whether they are certified organic or not, as they are simply good management practices. These practices will prevent many illnesses, assuming there is a closed flock. However, when illnesses do arise, you must remember that conventional treatments such as antibiotics are not approved for organic production. You will have to find alternative treatments. If those are not effective, then you must use the conventional treatment for humane reasons, and remove the treated animal from organic status. In humid climates, goats and sheep may have serious trouble with internal parasites. Internal parasites can be devastating to the health of the animal, causing loss of productivity and sometimes death. Under the National Organic Program regulations, use of chemical dewormers is restricted for breeding and milking stock (they may not be used on lactating does or ewes, or does and ewes in the last trimester of pregnancy, or on any animals routinely) and is prohibited for organic slaughter stock. If infection is severe, you should use the most effective treatment, including chemical dewormers if necessary. Animals treated with chemical dewormers are no longer certified organic and must be removed from the organic herd or flock. Organic production is probably not a viable option for producers who raise goats or sheep in climates that are extremely conducive to internal parasite infections.

See *Managing Internal Parasites in Sheep and Goats* for more information about this important topic. See also *NCAT's Organic Livestock Workbook* to get a fuller picture of what is involved in organic livestock production. ATTRA has many other publications that deal with organic certification as well.

## Related ATTRA Publications

*NCAT's Organic Livestock Workbook*

*Organic Farm Certification and the National Organic Program*

*Organic Standards for All Organic Operations*

*Organic Standards for Livestock Production*

*Organic Certification Process*

*Organic Livestock Documentation Forms*

For additional information on organic goat or sheep production, see the MOSES article *Transitioning to Organic Sheep or Goat Meat Production*

[www.mosesorganic.org/attachments/productioninfo/stransgsmeat.html](http://www.mosesorganic.org/attachments/productioninfo/stransgsmeat.html)

A good, concise article about organic goat production is: *Organic Meat Goat Production* (Langston University) [www.luresext.edu/goats/training/organic.html](http://www.luresext.edu/goats/training/organic.html)

## Appendix B: Diseases in Flock or Herd

---

What are the main health problems and diseases in your herd or flock? Get advice from your veterinarian to prevent them as much as possible. See **Appendix D** for resources to help you learn more about nutrition and about how to improve the health of your flock or herd.

### Nutritional

- Acidosis
- Bloat
- Ketosis
- Milk fever
- Listeriosis
- Polio
- Enterotoxemia Type C
- Enterotoxemia Type D (over-eating disease)  
Mineral Imbalance
- Copper (Cu)— Copper Toxicity (sheep) or  
Copper Deficiency (goats)
- Selenium (Se)—White Muscle Disease
- Zinc (Zn)
- Magnesium (Mg)— Grass Tetany
- Potassium (K)
- Calcium: Phosphorus (Ca:P) — Milk fever,  
urinary calculi

### Parasites

- External
- Mange
- Keds
- Ticks
- Lice
- Wool Fungus
- Internal Parasites
- Coccidia
- Nematodes

### Respiratory

- Pneumonia

### Genetic

- Spider Syndrome (sheep)
- Over- or under-shot jaw
- Extra teats
- Deformities

### Bacterial

- Foot rot
- Enterotoxemia—Type C or D
- Pinkeye
- Tetanus
- CL— Caseous Lymphadenitis
- Johne's

### Viruses/Other

- OPP— Ovine Progressive Pneumonia (sheep)
- CAE—Caprine Arthritis Encephalitis (goats)
- CE— Contagious ecthyma (soremouth)
- Scrapie

### Abortions

- Toxoplasma
- Campylobacter
- Chlamydia
- Leptospirosis
- Stress
- Physical or Mechanical Trauma
- Unknown

### Reproductive

- Brucellosis
- Dystocia
- Prolapse (vaginal, uterine, rectal)
- Epididymitis

### Other

---

---

---

# Appendix C: Resource Assessments

---

## I. Assessment of Individual Pastures

Routine pasture assessment can be used effectively as a feed budgeting process as well as an evaluation of how well your grazing program is working and how individual pastures (paddocks) should be managed. Individual pastures should be evaluated regularly to make short-term management decisions such as grazing pressure, fertility needs, forage availability within a short time span, or potential for hay production. Pasture assessment can be as important to your operation as animal evaluation (and economically, may be more important). Each pasture should be assessed at various times of the year. Additionally, when assessing a pasture, evaluate how previous management and use has affected the pasture.

What are your pasture management goals? \_\_\_\_\_

Do you need to make better-quality forage available, which might be accomplished with haying earlier or using better grazing practices? \_\_\_\_\_

Do you know how individual pastures rank in productivity? \_\_\_\_\_

Are there spots of bare ground within pastures? \_\_\_\_\_

Do you have any erosion problems? \_\_\_\_\_

What changes in plant species are occurring? \_\_\_\_\_

Are these changes desirable or undesirable? \_\_\_\_\_

Is the pasture grazed fairly uniformly, or are there areas of spot grazing? \_\_\_\_\_

Is there adequate but not excessive plant residue in the pasture? \_\_\_\_\_

Is the residue decomposing properly, or is it thick enough to contribute to lack of seedling development in other species such as clover? \_\_\_\_\_

Are the animals doing a good job of controlling the edible weeds, such as ragweed, when vegetative? \_\_\_\_\_

Which weeds or brush are not being controlled by grazing? \_\_\_\_\_

Are there compaction or pugging problems? \_\_\_\_\_

Could a change in water/mineral feeder location or the shape of pasture affect the grazing pattern? \_\_\_\_\_

Is wildlife habitat appropriate? \_\_\_\_\_

Is water runoff excessive, especially on slopes? \_\_\_\_\_

Do you need more forage, which might be gained through an application of fertilizer or a longer rest period? \_\_\_\_\_

Are pastures resting long enough to allow proper plant re-growth and replenishment of root reserves? \_\_\_\_\_

Are there areas of pastures that need fertilizer and other areas that don't? \_\_\_\_\_

Which field areas dry out first, second, and last under drought conditions? \_\_\_\_\_

Do you plan for which pastures are used at different times of the year? \_\_\_\_\_

Do you drive on pastures, which may retard pasture growth and create compaction problems? \_\_\_\_\_

## II. Assessment of Soils

Soil is the natural-resource foundation of any farm. Proper management of the soil is the basis for managing the plant-animal interaction necessary for a sustainable livestock farm. Whole-farm planning includes an assessment of soil characteristics. First, study how everyday management influences nutrients, moisture levels, and tilth. This is the basis for decisions on fertilizing and grazing, activities that will affect species diversity and erosion. It is important to understand where your best soil is, as well as how to improve the quality of all your soil. A nutrient management plan can be used to determine sources of nutrients that can improve the farm's productivity at minimum costs.

- \_\_\_\_\_ Do you have soil maps of your farm and understand the productivity index of each soil type? \_\_\_\_\_
- \_\_\_\_\_ Do you have specific problems to address, such as fragipans, poor drainage, or compaction? \_\_\_\_\_
- \_\_\_\_\_ What is the microbial activity in your soil? \_\_\_\_\_ What does the soil smell like? \_\_\_\_\_
- \_\_\_\_\_ What is the tilth? \_\_\_\_\_ What does a handful feel like? \_\_\_\_\_
- \_\_\_\_\_ Do you have a nutrient management plan for each pasture? \_\_\_\_\_
- \_\_\_\_\_ When was your last soil test? \_\_\_\_\_
- \_\_\_\_\_ What is soil pH, salinity and sodium (Na) saturation? \_\_\_\_\_
- \_\_\_\_\_ Do you routinely use lime? \_\_\_\_\_
- \_\_\_\_\_ What is the organic matter level in your pastures/fields? \_\_\_\_\_
- \_\_\_\_\_ How deep is the dark surface layer? \_\_\_\_\_
- \_\_\_\_\_ Is it less than the natural undisturbed soils in your area? \_\_\_\_\_
- \_\_\_\_\_ How many days does it take grass or crops to exhibit drought stress? \_\_\_\_\_
- \_\_\_\_\_ Are earthworms easy to find? \_\_\_\_\_
- \_\_\_\_\_ Is there evidence of earthworm activity, such as castings on the surface? \_\_\_\_\_
- \_\_\_\_\_ How fast do manure piles and forage thatch degrade? \_\_\_\_\_
- \_\_\_\_\_ Are any plants yellow, spotty, or purple? \_\_\_\_\_
- \_\_\_\_\_ Do you have any soil nutrient deficiencies or imbalances that impair forage and animal production? \_\_\_\_\_
- \_\_\_\_\_ Do you have considerable variation of productivity levels and nutrient levels within pastures? \_\_\_\_\_
- \_\_\_\_\_ Are soil fertility levels adequate to meet forage production targets? \_\_\_\_\_
- \_\_\_\_\_ Are forage production targets too high, requiring inputs that are undesirable for environmental or economic reasons? \_\_\_\_\_
- \_\_\_\_\_ Based on productivity of the soil, would a change in fencing allow better use of pastures? \_\_\_\_\_
- \_\_\_\_\_ Are any erosion problems due to poor water flow control, inadequate cover, or soil compaction? \_\_\_\_\_
- \_\_\_\_\_ Do you have soil compaction problems in any fields? \_\_\_\_\_
- \_\_\_\_\_ How long does it take for standing water to seep in? \_\_\_\_\_
- \_\_\_\_\_ Do you regularly sample soil of individual fields or soil types? \_\_\_\_\_



### III. Assessment of Watershed

Every farm is part of a watershed. Water flows onto the farm and leaves the farm. What happens in the process is the responsibility of the farm owner and can have an impact on both the water quality downstream and soil erosion problems on the farm. An understanding of the geological formations of the farm may assist in evaluating water flow and managing water quality.

\_\_\_\_\_ What are the water drainage patterns into and from your farm? \_\_\_\_\_

\_\_\_\_\_ Are there litter banks (debris piles, usually wood) present anywhere on your land? \_\_\_\_\_

\_\_\_\_\_ How efficient are you in retaining water on your farm and in your soils? \_\_\_\_\_

Riparian areas are the edges of streams, wet weather creeks, ditches, or anywhere water flows through at various times of the year. Management of these areas can have an impact on erosion and water quality.

\_\_\_\_\_ Do you have major riparian areas with flowing water in them most of the time? \_\_\_\_\_

\_\_\_\_\_ Do you have riparian areas with large amounts of water at limited times during the year? \_\_\_\_\_

\_\_\_\_\_ Do you have a management plan for your riparian areas? \_\_\_\_\_

\_\_\_\_\_ Does your plan allow livestock frequent, limited access to help manage the vegetation of riparian areas? \_\_\_\_\_

\_\_\_\_\_ Are riparian areas managed for wildlife habitat? \_\_\_\_\_

\_\_\_\_\_ Do you have buffer zones adjacent to the riparian areas? \_\_\_\_\_

\_\_\_\_\_ Are farm ponds full of algae? \_\_\_\_\_

\_\_\_\_\_ Considering your whole farm as a watershed, do nutrients that contribute to poor water quality leave your farm? \_\_\_\_\_

\_\_\_\_\_ Do you time your fertilizing or spreading of litter/manure to prevent runoff of nutrients? \_\_\_\_\_

\_\_\_\_\_ Do aquatic organisms downstream indicate good water quality? \_\_\_\_\_ Has this changed? \_\_\_\_\_

\_\_\_\_\_ Do you use pesticides/herbicides tactically for localized infestation? \_\_\_\_\_

\_\_\_\_\_ If using poultry litter or other manures, do you test soil to monitor nutrient levels of individual pastures? \_\_\_\_\_

\_\_\_\_\_ Does your soil absorb and retain rainfall? \_\_\_\_\_

\_\_\_\_\_ Is the vegetation adequate to allow water penetration into the soil and prevent excessive runoff? \_\_\_\_\_

\_\_\_\_\_ Are some areas overgrazed to the extent that runoff is excessive? \_\_\_\_\_

\_\_\_\_\_ Do you have an understanding of the nutrient flow on your farm (inputs and outputs) and know what percentage is retained on the farm? \_\_\_\_\_

# Appendix D: Small Ruminant Resources

---

Following are many sources of information helpful to producers of small ruminants. Further resources may be available at your county Extension office, through your state land-grant university, or your local library.

## Types of Resources

### **ATTRA Publications**

ATTRA publications are available at no cost and may be requested by calling 800-346-9140. You may also download publications at our Web site: [www.attra.ncat.org](http://www.attra.ncat.org).

### **Books**

The books listed offer useful information on a wide variety of production and marketing issues. These titles may be available at your local library or through inter-library loan. Most of these books will be worthwhile purchases for those new to sheep or goat production. Previewing the books at a library is the best way to select the titles that will be most useful to you.

Used copies may be available through on-line services or through other booksellers. Many suppliers of sheep and goat equipment also offer books in their catalogs, and titles are available from the publishers as well.

### **Web sites**

This is not intended to be a comprehensive list, but these Web sites offer convenient access to a lot of information. Web sites frequently change; please let us know if a link does not work so we can keep this list current. Call 800-346-9140 to report any problems with this list.

### **Other resources**

Included here are DVDs and other useful tools that do not fit into the above categories.

A sampling of magazines, organizations, suppliers, and publishers is listed at the end of the document. Listing does not imply endorsement.

Resources are numbered to help users of ATTRA's *Small Ruminant Sustainability Checksheet* locate relevant information for improving their farms. This list works in tandem with the Farm Action Plan included in that document.

## **I. General: Sheep and Goats**

### **1) An Illustrated Guide to Sheep and Goat Production**

*This basic and heavily illustrated introduction to sheep and goat production discusses animal selection, feeding, breeding and young stock, equipment and handling, and marketing.*

### **2) Small Ruminant Sustainability Checksheet**

*This checksheet is designed to stimulate critical thinking when evaluating a farm that produces sheep or goats. The sustainability of a farm depends on many factors involving farm management, use of resources, and quality of life. The questions in the checksheet are intended to stimulate awareness rather than to rate management practices. Use this guide to define areas in your farm management that might be improved, as well as to identify areas of strength.*

### **3) Small-Scale Livestock Farming: A Grass Based Approach for Health, Sustainability, and Profit**

Ekarius, Carol. 1999. Storey Books, Pownal, VT. 217 p.

*Not specific to any species of livestock; contains farmer profiles and quite a bit of holistic planning and economic information. Very complete in treatment of rotational grazing.*

### **4) Sheep Housing and Equipment Handbook**

Hirning, Harvey J., Tim C. Faller, Karl J. Hoppe, Dan J. Nudell, and Gary E. Ricketts. 1994. MidWest Plan Service, Ames, IA. 90 p.

*These plans are also useful for goats, and include a few plans specific to goats.*

## 5) USDA

[www.usda.gov](http://www.usda.gov)

To go directly to the sheep and goat information, use this link: [http://riley.nal.usda.gov/nal\\_display/index.php?info\\_center=8&tax\\_level=2&tax\\_subject=10&topic\\_id=1735](http://riley.nal.usda.gov/nal_display/index.php?info_center=8&tax_level=2&tax_subject=10&topic_id=1735)

## 6) NRCS

[www.nrcs.usda.gov](http://www.nrcs.usda.gov)

## 7) ATTRA—National Sustainable Agriculture Information Service

[www.attra.ncat.org](http://www.attra.ncat.org)

## 8) Maryland Small Ruminant Page

[www.sheepandgoat.com](http://www.sheepandgoat.com)

*Don't miss this site. It is the most comprehensive and easy-to-use site for sheep and goat producers, and links to many of the Web resources listed in this document. The site is so extensive that using the search function is recommended; otherwise, it might take several clicks to find what you are looking for. The home page alone contains a wealth of information, including links to PowerPoints and spreadsheets, the Sheep 101 and Sheep 201 courses, the Wild and Woolly Sheep and Goat Newsletter, a reference list that includes many fine books and tabs to many useful articles covering every conceivable aspect of sheep and goat production. This portal is run by Susan Schoenian, University of Maryland Extension, and it is the first place to go if you have Web access. Her work is top-notch. The site includes numerous resources not contained in this ATTRA resource list.*

## 9) Kentucky Sheep and Goat Development Office

[www.kysheepandgoat.org](http://www.kysheepandgoat.org)

## 10) Sheep and Goat Extension and Research, Texas A&M University

<http://animalscience.tamu.edu/academics/sheep-goats/index.htm>

## 11) Sheep and Goats, Virginia Polytechnic Institute and State University Extension

<http://pubs.ext.vt.edu/category/sheep-goats.html>

## II. General: Sheep

### 12) Dairy Sheep

*This publication offers additional information and resources and includes a quick overview of production considerations.*

### 13) Sheep: Sustainable and Organic Production

*This publication takes a look at breed selection, feeding, health management, and innovative marketing of meat and wool products.*

## 14) Storey's Guide to Raising Sheep: Fourth Edition

Simmons, Paula and Carol Ekarius. 2009. Storey Publishing, LLC., Pownal, VT. 400 p.

*This book is a very useful resource covering many aspects of raising and marketing sheep and their products. Enjoyable to read and helpful to both beginners and experienced producers.*

## 15) Storey's Barn Guide to Sheep

Burns, Deborah, Sarah Guaro and Dale Perkins, editors. 2006. Storey Publishing, LLC. Pownal, VT. 96 p.

*This spiral-bound book with large, heavy-duty pages is designed to accompany the farmer to the barn and is complete with step-by-step guides and many straightforward illustrations. A companion to Storey's Guide to Raising Sheep.*

## 16) Practical Lambing and Lamb Care: Third Edition

Eales, Andrew, John Small and Colin Macalodowie. 3rd Edition. 2004. Blackwell Publishing, Ltd., Oxford, U.K. 272 p.

*This book provides practical guidance on all aspects of lambing and lamb care, including preventing and dealing with health issues, and ewe care.*

**17) Managing Your Ewe**

Lawson, Laura. 1997. LDF Publications, Culpeper, VA. 352 p.  
*Information on preparation for breeding, lambing, and aftercare.*

**18) Changes in the Sheep Industry**

National Research Council. 2008. The National Academic Press, Washington, D.C. 347 p.  
*A comprehensive report covering the history and current state of the U.S. sheep industry. Also includes information on breeds, health issues, and marketing.*

**19) Sheep Success**

Griffith, Nathan. 2000. Cobblemead Publications, Trout, WV. 204 p.  
*Long-established but not widely known strategies for breeding, growing, and selling sheep.*

**20) Sheep Production Handbook**

*This reference handbook, covering the basics of sheep production, is for beginning and experienced sheep producers alike.*

American Sheep Industry Association  
9785 Maroon Circle, Suite 360  
Englewood, CO 80112  
303-771-3500, ext. 32  
[www.sheepusa.org](http://www.sheepusa.org)

**21) American Sheep Industry Association**

[www.sheepusa.org](http://www.sheepusa.org)

**22) Hair Sheep Research and Information**

[www.sheepandgoat.com/HairSheepWorkshop/index.html](http://www.sheepandgoat.com/HairSheepWorkshop/index.html)

**23) National Sheep Improvement Program**

[www.nsip.org](http://www.nsip.org)

**24) Oregon State University**

<http://lans.oregonstate.edu/extension/sheep/index.htm>

**25) Penn State Sheep Publications**

<http://pubs.cas.psu.edu/PubTitle.asp?varTitle=sheep&Submit=Go>

**26) Sheep Extension Program, Farm Flock Sheep Production Handbook, Montana State University**

<http://animalrangeextension.montana.edu/articles/sheep/handbook/handbook-TOC.htm>

**27) Sheep Information - Cornell University STAR System**

[www.ansci.cornell.edu/sheep/management/breeding/star/](http://www.ansci.cornell.edu/sheep/management/breeding/star/)

**28) University of Kentucky Sheep Publications**

[www.uky.edu/Agl/AnimalSciences/farm/sheep/pub.htm](http://www.uky.edu/Agl/AnimalSciences/farm/sheep/pub.htm)

**29) University of Minnesota Extension Sheep Publications**

[www.extension.umn.edu/listing.html?topic=8&subcat=79](http://www.extension.umn.edu/listing.html?topic=8&subcat=79)

**30) University of Tennessee Sheep Extension**

<http://animalscience.ag.utk.edu/Sheep/Publications-Sheep.html>

**31) University of Wisconsin Sheep Extension**

[www.ansci.wisc.edu/Extension-New%20copy/sheep/index.html](http://www.ansci.wisc.edu/Extension-New%20copy/sheep/index.html)

**32) Sheep Management Wheel**

[www.pipestonesheep.com/sheepmanagementwheel.html](http://www.pipestonesheep.com/sheepmanagementwheel.html)

To order a Pipestone Sheep Management Wheel, send \$10 (checks payable to Minnesota West) to:  
Pipestone Lamb and Wool Program  
1314 North Hiawatha  
P. O. Box 250  
Pipestone, MN 56164  
or contact at:  
Phone: 507-825-6806

*The Pipestone Sheep Management Wheel is designed to make ewe flock management decisions simple and easy. The wheel is basically a management calendar. It works by setting the date you lamb, and all the management tasks that you need to do for the ewe and her lambs for the entire year are indicated on the wheel.*

### III. General: Goats



#### 33) Meat Goats: Sustainable Production

*Offers information specific to meat goat production and should be read after the companion publication, Goats: Sustainable Production Overview. This document discusses selection, breeds, marketing, feeding, profitability, and other topics. It includes sample budgets, case studies of farms in Montana and Missouri, and many further resources.*



#### 34) Goats: Sustainable Production Overview

*Discusses considerations of raising goats on pasture, including grazing, supplemental feeding, health concerns, reproduction, and management, as well as marketing and profitability.*



#### 35) Dairy Goats: Sustainable Production

*This publication is intended for those interested in starting a commercial goat dairy. It discusses the five major considerations to be addressed in planning for dairy goat production: labor, sales and marketing, processing, regulations, and budgeting and economics. It includes production information specific to dairy goats, including choosing breeds and selecting stock.*

#### 36) Meat Goats: Their History, Management, and Diseases

Mitcham, Stephanie and Allison Mitcham. 2000. Crane Creek Publications, Sumner, IA. 264 p.

*A well-written combination of the authors' personal experiences raising goats, veterinary knowledge (Stephanie Mitcham is a DVM), and a compilation of information from other experts in the field. Includes information about handling systems (hard to find elsewhere).*

#### 37) Storey's Guide to Raising Dairy Goats

(Revised and updated; originally called *Raising Milk Goats the Modern Way*)

Belanger, Jerry. 2001. Storey Books, Pownal, VT. 288 p.

*Very good general information for producers of dairy goats.*

#### 38) Goats and Goatkeeping

Thear, Katie. 1988. Merehurst Press, London, U.K. 176 p.

*Very interesting book for goat producers, geared for the small farm. Covers milk, meat, and fiber. Practical and concise, very similar to The New Goat Handbook, but with added detail.*

#### 39) The Goat Handbook

Judas, Ulrich and Seyedemehdi Mobini. 2006. Barron's Educational Series, Inc., Hauppauge, NY. 144 p.

*The compact size of this book makes it easy to keep handy, and it is full of photographs, line drawings, and useful information. Includes basic information on care, housing, breeding, and upkeep in non-technical language.*

#### 40) Goat Husbandry: Fifth Edition, revised and edited by Ruth Goodwin

Mackenzie, David. 1993. Faber & Faber, London, U.K. 355 p.

*British terminology, very good reading — a classic.*

- 41) Angora Goats the Northern Way: Fourth Edition**  
Drummond, Susan Black. 1993. Stoney Lonesome Farm, Freeport, MI. 239 p.
- 42) Raising Goats for Milk and Meat: Third Edition**  
Sinn, Rosalee. 2008. Heifer International, Little Rock, AR. 218 p.  
*Written for producers with limited resources, this is a very practical book, much expanded over the previous version; don't miss the chapter on health, which includes emphasis on prevention. Educators will appreciate the format of this book, in which the 10 chapters are presented as learning guides and lessons. This is an ideal course for educators working with groups and for self-study.*
- 43) Your Goats: A Kid's Guide to Raising and Showing**  
Damerow, Gail. 1993. Storey Books, Pownal, VT. 172 p.  
*Gail Damerow writes very good books; this one is easy to understand and very informative. Not just for kids.*
- 44) Raising Meat Goats for Profit**  
Bowman, Gail. 1999. Bowman Communications, Inc., Twin Falls, ID. 256 p.  
*This "how-to" book is a wonderful resource for goat breeders. It includes information about the meat breeds, how to get started with meat goat production, feed ration tables, kidding and raising kids, how to sell your goats, and information on health and diseases, as well as recipes.*
- 45) Storey's Guide to Raising Meat Goats**  
Sayer, Maggie. 2007. Storey Publishing, LLC., Pownal, VT. 320 p.
- 46) Simply Meat Goats**  
Solaiman, Sandra G. 2006. George Washington Carver Agricultural Experiment Station, Tuskegee University, Tuskegee, AL. 118 p.
- 47) Oklahoma Basic Meat Goat Manual**  
Oklahoma Cooperative Extension Service and Oklahoma State University. 2008. Oklahoma State Extension. 100 p.  
To view online or order a copy, visit <http://meatgoat.okstate.edu> or contact JJ Jones at 580-332-7011.
- 48) Meat Goat Production Handbook**  
Gipson, T.A., R.C. Merkel, and S. Hart. 2008. American Institute for Goat Research, Langston, OK. 418 p.  
*Comprehensive and highly useful guide to meat goat production and marketing. See content online at [www.luresext.edu/goats/training/qa.html](http://www.luresext.edu/goats/training/qa.html) (Web-based Training and Certification Program for Meat Goat Producers). This spiral-bound book is a handy reference.*  
To acquire a copy, write to  
MGPH  
Langston University  
Box 730  
Langston, OK 73050  
or access the order form at [www.luresext.edu/goats/handbookorderform.pdf](http://www.luresext.edu/goats/handbookorderform.pdf). Current cost is \$50, which includes shipping and handling in the U.S.
- 49) Goats: Small-scale Herding for Pleasure and Profit**  
Weaver, Sue. 2006. Bow Tie Press. 160 p.  
*This introductory book discusses choosing, breeding, and tending goats.*
- 50) Nutrient Requirements of Small Ruminants: sheep, goats, cervids, and new world camelids**  
NRC. 2007. National Academy Press, Washington, DC.
- 51) A Compilation of the Wit and Wisdom of "The Goat Man"**  
Pinkerton, Frank. 2010. Published by Goat Rancher Magazine. 334 p.  
*Dr. Pinkerton has been involved in every aspect of the goat industry and he writes very well, managing to be educational and funny at the same time. This book deals with all aspects of goat production, but is*

*especially strong in the areas of marketing of meat goats, goat enterprise economics and production testing, vital areas that are often overlooked in goat production books.*

**52) Web-based Training and Certification Program for Meat Goat Producers**

[www.luresext.edu/goats/training/qa.html](http://www.luresext.edu/goats/training/qa.html)

**53) Meat Goat Home Study Course, Penn State Extension**

<http://bedford.extension.psu.edu/agriculture/goat/Goat%20Lessons.htm>

**54) Langston University–E (Kika) de la Garza American Institute for Goat Research**

[www2.luresext.edu/goats/index.htm](http://www2.luresext.edu/goats/index.htm)

*This Web site is packed with solid information for goat producers, whether they raise meat, dairy, or fiber goats. From the home page, you can connect to the Web-based training course (see 52 above), the online manual for conducting fecal egg counts, nutrient requirements calculators (for balancing rations) and more. Use the search button to find information on many goat production topics.. The Web-based training course can be browsed and then read one chapter at a time; this is one of the best places to go for information on any aspect of meat goat production.*

**55) Nutrient Requirements of Goats (1981 edition)**

[www.nap.edu/openbook.php?record\\_id=30&page=1](http://www.nap.edu/openbook.php?record_id=30&page=1)

*This version is very accessible and useful, but be aware that there is an updated version. See entry above in the book listings.*

**56) North Carolina State University – Extension Animal Husbandry (see Meat Goat)**

[www.cals.ncsu.edu/an\\_sci/extension/animal/eahmain.html](http://www.cals.ncsu.edu/an_sci/extension/animal/eahmain.html)

**57) Meat Goat Selection, Carcass Evaluation, and Fabrication Guide**

[www.lsuagcenter.com/en/crops\\_livestock/livestock/sheep\\_goats/Meat+Goat+Selection+Carcass+Evaulation+and+Fabrication.htm](http://www.lsuagcenter.com/en/crops_livestock/livestock/sheep_goats/Meat+Goat+Selection+Carcass+Evaulation+and+Fabrication.htm)

**58) Tennessee Grazing Planner**

[www.tn.nrcs.usda.gov/technical/grazing/docs/calendar%202008%20goats.pdf](http://www.tn.nrcs.usda.gov/technical/grazing/docs/calendar%202008%20goats.pdf)

**59) Goat World**

[www.goatworld.com](http://www.goatworld.com)

**60) Boer and Meat Goat Information**

[www.boergoats.com](http://www.boergoats.com)

**61) Penn State Meat Goat Research and Publications**

[www.das.psu.edu/goats/research](http://www.das.psu.edu/goats/research)

**62) American Dairy Goat Association**

[www.adga.org/](http://www.adga.org/)

**63) The Dairy Goat Journal**

[www.dairygoatjournal.com](http://www.dairygoatjournal.com)

**64) Wisconsin Dairy Artisan Network**

<http://wisconsindairyartisan.org/goats.html>

**65) Meat Goat Management Wheel**

<http://extension.missouri.edu/publications/DisplayPub.aspx?P=MP913>

*The versatile, easy-to-use Meat Goat Management Wheel simplifies decisions about meat goat management and production. The wheel is a management calendar that helps you schedule tasks. It contains lots of general management information that can be adjusted for individual operations and different management styles.*

Order from University of Missouri Extension Publications

<http://extension.missouri.edu/publications/>

573-882-7216

## 66) Meat Goat Production and Marketing DVD

[www.ssawg.org/virtualfarm.html#goats](http://www.ssawg.org/virtualfarm.html#goats)

*This video illustrates the story of Bill Legg's pastured meat goat operation, within the setting of his diverse Tennessee farm. The practical information includes goat breeds and breeding tips, pasture management, pest control, marketing, and more – as told by the farmer.*

### **Southern Sustainable Agriculture Working Group (SSAWG) DVD series**

*Southern SAWG's video series titled *Natural Farming Systems in the South* provides an easy, economical way to take a virtual tour of some highly successful farming operations in the region. Compiled in partnership with the USDA's Risk Management Agency, these broadcast-quality videos feature farmers who detail in plain-spoken terms their whole farming systems and each component unique to their particular operations.*

*Videos in the series include *Meat Goat Production and Marketing*, *Artisan Cheese Making*, and more. Visit [www.ssawg.org/virtualfarm.html](http://www.ssawg.org/virtualfarm.html) to order the videos, take virtual farm tours, download the *Meat Goat Resource List*, or watch short video clips. Call 479-251-8310 to order DVDs. Currently they are \$15 each (plus shipping and handling).*

## IV. Forages



### 67) Assessing the Pasture Soil Resource

*How to take a soil sample and an easy way to assess soil biological activity and water infiltration. Assessment sheet included.*



### 68) Multispecies Grazing

*Brief overview of why multispecies grazing is beneficial, as well as considerations for management.*



### 69) Paddock Design, Fencing, and Water Systems for Controlled Grazing

*This publication covers some of the basics of paddock design and current fencing and water technology.*



### 70) Rotational Grazing

*How to manage pastures and grazing animals to make more profitable use of a farm's resources.*



### 71) Pastures: Sustainable Management

*This publication looks at managing fertility and pests, grazing systems, conserved forages, and maintaining productivity. It includes additional resources.*



### 72) Pasture, Rangeland, and Grazing Management

*This publication profiles the general types of pastures and rangelands and offers information about management and expected yields. Weed management strategies are also discussed, and tips are offered to rehabilitate depleted land. Issues in grazing management, such as paddock development, plant selection, drought and plant toxicosis, are also discussed. Resources and references are also included.*



### 73) Pastures: Going Organic

*This publication is an introduction to regulations related to organic pasture and rangeland in the United States. Fertility, weed, and insect pest management issues are briefly addressed. Organic integrity is discussed, including records required to demonstrate compliance with the National Organic Standards. References and resources follow the narrative.*



### 74) Ruminant Nutrition for Graziers

*This publication provides managers with tools and references to assess biological and climatological variables and make decisions that ensure the ecological and economic viability of a grass-based ruminant operation.*

### 75) Small-Scale Livestock Farming: A Grass Based Approach for Health, Sustainability, and Profit

Ekarius, Carol. 1999. Storey Books, Pownal, VT. 217 p

*Not specific to any species of livestock; contains farmer profiles and quite a bit of holistic planning and economic information. Very complete in treatment of rotational grazing.*



## 76) Southern Forages

Ball, D.M., C. S. Holveland, and G.D. Lacefield. 2002. Potash & Phosphate Institute (PPI). Norcross, Georgia. 322 p.

*This handy book includes color photos to help in forage identification, as well as very readable and useful treatments of forage programs, options in forages, establishing forages, managing grazing, minimizing stored feed requirements, dealing with poisonous plants, and much more. A chapter on forage quality is followed by a chapter on the nutrient requirements of livestock. All graziers in the South will benefit from reading and using this book. Printed on durable enameled paper, this book is compact and includes lots of tables, graphics and photos. Softcover. "From dashboards of trucks to libraries, this book will be dog-eared from regular use." (Dr. Jimmy Henning, University of Kentucky Extension Forage Specialist)*

Order from:

Potash & Phosphate Institute (PPI)  
655 Engineering Drive, Suite 110  
Norcross, GA 30092-2837  
Phone: 770-825-8082  
E-mail: [circulation@ppi-far.org](mailto:circulation@ppi-far.org)

## 77) Comeback Farms: Rejuvenating Soils, Pastures and Profits with Livestock Grazing Management

Judy, Greg. 2008. Acres USA. Austin, TX. 278 p.

*This book expands on the cattle operation and includes first-hand experience with high density multi-species grazing, specifically for sheep, goats, and pigs. Tips are included on how to work with nature without costly inputs and letting the animals be your labor force.*

## 78) Targeted Grazing: A Natural Approach to Vegetation Management and Landscape Enhancement

National Sheep Industry Improvement Center and American Sheep Industry Association. 2006. American Sheep Industry Association, Centennial, CO. 199 p.

To view online or order a copy, visit [www.cnr.uidaho.edu/rx-grazing/Handbook.htm](http://www.cnr.uidaho.edu/rx-grazing/Handbook.htm) or contact American Sheep Industry Association  
9785 Maroon Circle, Suite 360  
Englewood, CO 80112  
303-771-3500, ext. 32

## 79) More Sheep, More Grass, More Money

Schroedter, Peter. 1997. Ramshead Publishing, Ltd. Moosehorn, Manitoba. p.112

*Personal experiences of the author emphasizing the need to make a profit with the sheep enterprise. It includes examples of how to cut costs and increase profits. Emphasis on grazing management. Very practical.*

## 80) Tennessee Grazing/Browsing Calendar

[www.tn.nrcs.usda.gov/technical/grazing/docs/calendar%202008%20goats.pdf](http://www.tn.nrcs.usda.gov/technical/grazing/docs/calendar%202008%20goats.pdf)

*While the title indicates "2008," this calendar is useful every year as a reminder of good management practices for your pasture and goats. This tool is concise, informative, and loaded with tips to benefit your whole farm. Record sheets are included at the end of the 23-page document.*

## 81) Intermountain Planting Guide

Jensen, Kevin, and Howard Horton, Ron Reed, and Ralph Whitesides. Utah State University. 106 p.  
[http://extension.usu.edu/files/publications/publication/pub\\_\\_7717229.pdf](http://extension.usu.edu/files/publications/publication/pub__7717229.pdf)

## 82) Extending Grazing and Reducing Stored Feed Needs

<http://lagebb.missouri.edu/mfgc/2009extgraz.pdf>

*This 20-page publication is ANR-1357 and is available at some Extension offices.*

## 83) University of Wisconsin Extension Pasture Management and Grazing

[www2.uwrf.edu/grazing](http://www2.uwrf.edu/grazing)

## 84) Livestock for Landscapes

[www.livestockforlandscapes.com](http://www.livestockforlandscapes.com)

**85) BEHAVE- Behavioral Education for Human Animal Vegetation and Ecosystem Management**

[www.behave.net](http://www.behave.net)

**86) Alberta Forage Manual**

[www1.agric.gov.ab.ca/\\$department/deptdocs.nsf/all/agdex16](http://www1.agric.gov.ab.ca/$department/deptdocs.nsf/all/agdex16)

**87) Montana State University**

<http://www.msuextension.org/store/Departments/Agriculture-Topic-Categories/Range-Management.aspx>

**88) ARS Range Monitoring Manuals**

[http://usda-ars.nmsu.edu/monit\\_assess/index.html](http://usda-ars.nmsu.edu/monit_assess/index.html)

**89) Interpreting Indicators of Rangeland Health**

[ftp://ftp-fc.sc.egov.usda.gov/GLTI/technical/publications/IIRH\\_v4\\_8-15-05.pdf](ftp://ftp-fc.sc.egov.usda.gov/GLTI/technical/publications/IIRH_v4_8-15-05.pdf)

**90) USDA Pasture Condition Score System**

<http://ddr.nal.usda.gov/bitstream/10113/37920/1/IND44315660.pdf>

**91) Guide to NRCS Pasture Condition Scoring**

<ftp://ftp-fc.sc.egov.usda.gov/GLTI/technical/publications/pasture-score-guide.pdf>

**92) Pasture Condition Score Sheet**

<ftp://ftp-fc.sc.egov.usda.gov/GLTI/technical/publications/pasture-score-sheet.pdf>

**93) Multi-Species Grazing and Leafy Spurge CD**

TEAM Leafy Spurge. 2002.  
USDA-ARS Northern Plains  
Agriculture Research Laboratory  
1500 North Central Avenue  
Sidney, MT 59270  
406-433-2020  
[www.team.ars.usda.gov](http://www.team.ars.usda.gov)

*This CD provides a variety of useful information about using grazing as an effective, affordable, and sustainable leafy spurge management tool. It contains economic reports, posters, photos, a PowerPoint presentation, extensive bibliography, and more. A great resource.*

**94) GOATS! For Firesafe Homes in Wildland Areas CD**

Kathy Voth  
6850 West County Road 24  
Loveland, CO 80538  
[www.livestockforlandscapes.com](http://www.livestockforlandscapes.com)

*This CD/Handbook is designed to provide fire managers, communities, and livestock owners information on using goats to reduce fire danger. It includes expected results, and the “hows” of managing animals, choosing treatment sites, developing contracts for services, estimating costs, and starting projects. This is a great CD with some excellent videos.*

## V. Animal Health



**95) Managing Internal Parasites in Sheep and Goats**

*This publication discusses new techniques to manage parasites and to prolong the efficacy of dewormers. New management tools that remain under investigation are also discussed. A list of resources follows the narrative.*



**96) Tools for Managing Internal Parasites in Small Ruminants: Copper Wire Particles**

*The publication contains information on how to make boluses of copper wire oxide particles and reports results of studies on the effectiveness of this treatment.*



**97) Tools for Managing Internal Parasites in Small Ruminants: Sericea Lespedeza**

*This publication discusses tools that can be used to manage internal parasites of sheep and goats that are*

becoming resistant to conventional wormers. One such tool is the forage sericea lespedeza, and the publication discusses how it can be used and presents the results of research on how it reduces parasites in small ruminants.

 **98) Predator Control for Sustainable and Organic Livestock Production**

*This publication focuses primarily on the control of coyotes and dogs, the main causes of livestock loss to predation, through management practices such as fencing and secure areas and the use of guard animals.*

 **99) Integrated Parasite Management for Livestock**

*With parasites developing resistance to all dewormers, and more farmers producing livestock by “natural” methods, there is interest in looking for alternative ways to manage parasite problems. This publication offers a systems approach to assess and manage the soil, forages, and animals to decrease internal parasites and their effects.*

**100) Sheep and Goat Medicine**

Pugh, D.G. 2002. W.B. Saunders Company, Philadelphia, PA. 468 p.

*A great gift for a veterinarian. A wealth of information for producers and for veterinarians. Knowledge of veterinary terminology will be helpful in using this book.*

**101) A Veterinary Guide for Animal Owners: Second Edition**

Spaulding, C.E and Jackie Clay. 2nd Edition. 2001. Rodale, Inc., Emmaus, PA. 432 p.

*A very readable and practical book with chapters on cattle, horses, hogs, sheep, goats, dogs and cats.*

**102) Keeping Livestock Healthy: Fourth Edition**

Haynes, N. Bruce. 2001. Storey Publishing, LLC., Pownal, VT. 352 p.

*Covers cattle, horses, swine, sheep, and goats. A good book for learning about diseases in general, with emphasis on prevention. Most attention is given to large animals.*

**103) ...May Safely Graze: Protecting Livestock Against Predators**

Fytche, Eugene. 1998. Published by the author. 103 p.

Available from:

Eugene Fytche

R.R. #1

Almonte, Ontario. K0A 1A0.

*This book explores how to identify and quantify the predator problem and includes information on many methods to control the predators, including guard animals, fencing, and management.*

**104) Livestock Guardians: Using Dogs, Donkeys, and Llamas to Protect your Herd**

Dohner, Jan Vorwald. 2007. Storey Publishing, LLC., Pownal, VT. 256 p.

*A comprehensive guide for farmers struggling to reduce predation of sheep, goats, and other livestock.*

**105) The Complete Herbal Handbook for Farm and Stable: Fourth Edition**

Bairaclli Levy, Juliette de. 1991. Faber & Faber, London, U.K. 471 p.

*Very interesting book offering a different perspective on prevention of disease and production of healthy animals without using conventional medicine.*

**106) The Dairy Practices Council Small Ruminant Guidelines**

Guidelines for the Dairy Industry Relating to Sanitation and Milk Quality for Small Ruminant Operations.

The Dairy Practices Council

51 East Front Street, Suite 2

Keyport, NJ 07735

732-264-2643

[www.dairypc.org](http://www.dairypc.org)

Set: \$70.00.

*A set of 17 Guidelines relating to small ruminants; each may also be purchased separately. Very good technical information for commercial producers of dairy sheep and goats.*

**107) Humane Livestock Handling**

Grandin, Temple. 2008. Storey Publishing. Pownal, VT. 227 p.

*Learn how to improve the day-to-day operation as well as the profitability of your farm by raising healthier, more contented animals. Temple Grandin shares dozens of methods and detailed plans she has developed for low-stress ways to move livestock on pastures, paddocks, and feedlot pens.*

**108) Small Ruminant Production Medicine and Management Manual**

*Infovets.com*

P.O. Box 494

Brigham City, UT 84302

877-424-7838

*This reference manual contains video, flow charts, photos, and procedure descriptions that are a must for any sheep and goat owner. Find answers to those everyday questions on management, birthing problems, disease prevention/treatment, the proper use of various products, and much more.*

**109) Alternative Treatments for Ruminant Animals**

Dettloff, Paul, DVM. 2004. Acres USA. Austin, TX. 246 p.

*www.acresusa.com/books/closeup.asp?prodid=1236&catid=11&pcid=2*

*This book provides information on natural, organic, and sustainable approaches to animal health. Includes information for sheep and goats.*

**110) Natural Goat Care**

Coleby, Pat. 2001. Acres USA. Austin, TX. 371 p.

*Fascinating book; Australian author pays much attention to nutrition and to maintaining health organically. Call 1-800-355-5313.*

**111) Goat Medicine, Second Edition**

Smith, Mary and David M. Sherman. 2009. Wiley-Blackwell, Baltimore, MD. 888 p.

*This book is recommended as a useful gift for a veterinarian. Very scientific; some of the terminology will be understood only by a veterinarian, but a few chapters are very useful to producers.*

**112) Goat Health Handbook: A Field Guide for Producers with Limited Veterinary Service**

Theford, T.R. 1983. Printed in collaboration with the Agricultural Experimental Station, University of Arkansas. 123 p.

Available from:

International Winrock Publication Sales

P.O. Box 9363

Arlington, VA 22209-0363

**113) Natural Sheep Care**

Coleby, Pat. 2006. Acres USA, Austin, TX. 215 p.

*This is a natural sheep care book with special attention devoted to breeding for finer wool and meat, land management, and treatment of diseases and other health problems*

**114) Living With Worms in Organic Sheep Production**

Stockdale, Peter. 2008. Canadian Organic Growers, Inc., Ontario, Canada. 79 p

*An excellent book that covers parasite life cycles, managing pastures and animals to prevent parasitism, and diagnosis and treatment of internal parasites.*

**115) The Sheep Keeper's Veterinary Handbook**

Winter, Agnes and Judith Charnley. 2007. The Crowood Press, Ltd., Ramsbury, Marlborough, U.K. 208 p.

*Covers the basics of keeping sheep and common health issues. Focuses on identifying healthy sheep and preventing disease.*

**116) American Association of Small Ruminant Practitioners**

*www.aasrp.org*

**117) National Scrapie Education Initiative**

*www.eradicatescrapie.org*

**118) Southern Consortium for Small Ruminant Parasite Control**

*www.scsrpc.org*

**119) Pipestone Veterinary Supply**

*www.pipevet.com*

## **VI. Marketing and Business**

 **120) Direct Marketing**

*This publication on direct marketing alternatives—with emphasis on niche, specialty, and value-added products—features many farm case studies, as well as information on enterprise budgets and promotion/publicity. A new section discusses implications of Internet marketing and e-commerce for agriculture.*

 **121) Evaluating a Rural Enterprise**

*This publication is for people who already live in rural areas and want to add new enterprises to their operations. Its sections guide the reader in evaluating resources, assessing finances, gathering information, and marketing. It also discusses choosing an “alternative” enterprise and offers further resources.*

 **122) Holistic Management**

*Introduction to holistic management. Holistic management is a decision-making framework that assists farmers and others in establishing a long-term goal, a detailed financial plan, a biological plan for the landscape, and a monitoring program to assess progress toward the goal. Holistic Management helps managers ask the right questions and guides them in setting priorities.*

 **123) Keys to Success in Value-Added Agriculture**

*This publication presents, largely in the words of fourteen farmers, important lessons they learned in adding value to farm products and marketing directly to consumers.*

 **124) Overview: Adding Value to Farm Products**

*This publication introduces the concept of value-added farm products, explains a few of the nuts and bolts for starting a food processing business, and provides resources for additional information.*

 **125) Value-Added Dairy Options**

*Considerations for those who want to increase profitability by bottling milk, making cheese or yogurt, or doing some other processing of their milk. This publication discusses regulations and organic milk certification and offers resources for further information.*

**126) Building a Sustainable Business: A Guide to Developing a Business Plan for Farms and Rural Business**

DiGiacomo, Gigi, Robert King, and Dale Nordquist. 2003. Minnesota Institute for Sustainable Agriculture, Saint Paul, MN, and the Sustainable Agriculture Network, Beltsville, MD. 280 p.

*Business planning is an important part of owning and managing a farm. Business plans help farmers demonstrate that they have fully researched their proposed enterprises; they know how to produce their products, how to sell what they produce, and how to manage financial risks. This comprehensive workbook will guide farmers through every step of the process in creating a business plan. Includes many examples from existing farms. This workbook is a bargain. Available for \$14.00 + \$3.95 S/H by calling 802-656-0484 or 800-909-6472. Publication can also be viewed and downloaded at [www.misa.umn.edu/vd/bizplan.html](http://www.misa.umn.edu/vd/bizplan.html).*

**127) Small-Scale Livestock Farming: A Grass Based Approach for Health, Sustainability, and Profit**

Ekarius, Carol. 1999. Storey Books, Pownal, VT. 217 p.

*Not specific to any species of livestock; contains farmer profiles and quite a bit of holistic planning and economic information. Very complete in treatment of rotational grazing.*

**128) Making Money with Goats**

Winslow, Ellie. 2005. Freefall Press. 193 p.

*This book covers many ways to make money with goats, including information on general production, goat milk, meat, skins, fiber, and business planning.*

**129) Turning Wool into a Cottage Industry**

Simmons, Paula. 1991. Storey Books, Pownal, VT. 188 p.

*This book is a big help to those who want to use fiber.*

**130) Changes in the Sheep Industry**

National Research Council. 2008. The National Academic Press, Washington, D.C. 347 p.

*A comprehensive report covering the history and current state of the U.S. sheep industry. Also includes information on breeds, health issues, and marketing.*

**131) Marketing out of the Mainstream: A producers' guide to direct marketing of lamb and wool**

Kirkpatrick, Tamra and James Bell. 1995. Sheep Industry Development Program. Englewood, CO. 57 p.

*Available as a PDF from the American Sheep Industry Web site. See [www.sheepusa.org/Publications](http://www.sheepusa.org/Publications). This site also includes up-to-date reports about marketing, and the Sheep Care Guide.*

**132) Holistic Management: A New Framework for Decision Making**

Savory, Allan, and Jody Butterfield. 1999. Island Press, Washington, D.C. 616 p.

*This is an in-depth look at how to assess your situation, form a mission statement, set goals and make plans to reach them in light of social, economic, and environmental concerns. While it is very long and introduces some difficult concepts and unfamiliar terminology, this book includes pictures, graphics, examples, and clear explanations. Understanding and applying the concepts of holistic management will lead to making better decisions for your land and your family.*

**133) Whole Farm Planning: Ecological Imperatives, Personal Values and Economics**

Henderson, Elizabeth, and Karl North. 2004. Northeast Organic Farming Association Interstate Council. Barre, MA. 92 p.

[www.nofa.org](http://www.nofa.org)

*Concise, simplified, unintimidating look at whole farm planning, packed with examples. This is a great place to start learning about holistic management.*

**134) Sheep and Goat Marketing Information**

<http://sheepgoatmarketing.info>

**135) Measuring and Analyzing Farm Financial Performance, Purdue Extension**

[www.agecon.purdue.edu/extension/programs/fbm21/Ec712entry.htm](http://www.agecon.purdue.edu/extension/programs/fbm21/Ec712entry.htm)

**136) A PRIMER for Selecting New Enterprises for Your Farm, University of Kentucky Extension**

[www.uky.edu/Ag/AgEcon/pubs/ext\\_aec/ext2000-13.pdf](http://www.uky.edu/Ag/AgEcon/pubs/ext_aec/ext2000-13.pdf)

**137) Holistic Management**

<http://holisticmanagement.org>

**138) Whole Farm Planning With Holistic Management**









[www.umass.edu/umext/ljgerber/hmpage/hmpage2/mainpage6.htm](http://www.umass.edu/umext/ljgerber/hmpage/hmpage2/mainpage6.htm)

## VII. Organic Production



**139) NCAT's Organic Livestock Workbook**

*This workbook has been created to help organic and transitional producers with livestock or mixed crop and livestock operations understand the range of practices and materials allowed under the National Organic Program Regulations. Particular emphasis is placed on farming strategies and practices that promote sustainability.*

-  **140) Pastures: Going Organic**  
*This publication is an introduction to regulations related to organic pasture and rangeland in the United States. Fertility, weed, and insect pest management issues are briefly addressed. Organic integrity is discussed, including records required to demonstrate compliance with the National Organic Standards. References and resources follow the narrative.*
-  **141) Organic Standards for All Organic Operations: Highlights of the USDA's National Organic Program Regulations**  
*This collection of excerpts from the USDA's National Organic Program (NOP) Final Rule provides the reader with key standards relevant to all certified organic operations.*
-  **142) Organic Standards for Livestock Production: Highlights of the USDA's National Organic Program Regulations**  
*This collection of excerpts from the U.S. Department of Agriculture's National Organic Program (NOP) provides the reader with key standards relevant to organic livestock producers.*
-  **143) Organic Certification Process**  
*This guide is designed to help organic producers and handlers understand, prepare for, and get the most from the process of organic certification to USDA National Organic Standards.*
-  **144) Organic Farm Certification and the National Organic Program**  
*Farmers planning to market their products as "organic" must become certified. This guide outlines the considerations involved in "going organic" and the basic steps to organic certification.*
-  **145) Organic System Plans: Livestock Production**  
*If you want to certify your livestock operation(s) as organic, you will need to complete an application form. This guide was developed to assist you in completing that application by explaining just what information certifiers want and why it is required.*
-  **146) Organic Livestock Documentation Forms**  
*In order to become certified organic, livestock producers must demonstrate to an accredited certifier that their operations comply with National Organic Program regulations. The 32 forms in this package are provided as tools that livestock producers can use for documenting practices, inputs, and activities that demonstrate compliance with regulations or that assist in other aspects of farm record keeping.*
-  **147) Organic Livestock Feed Suppliers Database**  
*One of the challenges of organic livestock production is locating the 100% organic feed required. This self-listing database helps producers locate sources of feed. Only available online at [http://attra.ncat.org/attra-pub/livestock\\_feed/](http://attra.ncat.org/attra-pub/livestock_feed/).*
- 148) Alternative Treatments for Ruminant Animals**  
 Dettloff, Paul, DVM. 2004. Acres USA. Austin, TX. 246 p.  
[www.acresusa.com/books/closeup.asp?prodid=1236&catid=11&pcid=2](http://www.acresusa.com/books/closeup.asp?prodid=1236&catid=11&pcid=2)  
*This book provides information on natural, organic, and sustainable approaches to animal health. Includes information for sheep and goats.*
- 149) Living With Worms in Organic Sheep Production**  
 Stockdale, Peter. 2008. Canadian Organic Growers, Inc., Ontario, Canada. 79 p.  
*An excellent book that covers parasite life cycles, managing pastures and animals to prevent parasitism, diagnosis and treatment of internal parasites.*
- 150) Transitioning to Organic Sheep or Goat Meat Production**  
<http://mosesorganic.org/attachments/productioninfo/fstransgsmeat.html>
- 151) Transitioning to Organic Sheep or Goat Dairy Production**  
<http://mosesorganic.org/attachments/productioninfo/fstransgsdairy.html>

## 152) National Organic Program

*Home page:* [www.ams.usda.gov/AMSv1.0/nop](http://www.ams.usda.gov/AMSv1.0/nop)

*Link to standards:* <http://ecfr.gpoaccess.gov/cgi/t/text/text-idx?c=ecfr&sid=89916dd414d154b401d29376f730a9b7&rgn=div5&view=text&node=7:3.1.1.9.32&idno=7>

*List of certifiers:* [www.ams.usda.gov/AMSv1.0/getfile?dDocName=STELPRDC507448](http://www.ams.usda.gov/AMSv1.0/getfile?dDocName=STELPRDC507448)

## 153) New Farm (Rodale)

*Home page:* [www.rodaleinstitute.org/new\\_farm](http://www.rodaleinstitute.org/new_farm)

*Certifier directory:* [www.rodaleinstitute.org/certifier\\_directory](http://www.rodaleinstitute.org/certifier_directory)

## 154) Organic Trade Association Organic Pages Online

[www.theorganicpages.com/topol/index.html](http://www.theorganicpages.com/topol/index.html)

## Vendors: Magazines

### Goat Rancher

Terry Hankins, editor and publisher  
731 Sandy Branch Road  
Sarah, MS 38665  
888-562-9529  
[www.goatrancher.com](http://www.goatrancher.com)  
\$29 per year (12 issues)

### Sheep! Magazine

W11564 Hwy. 64  
Withee, WI 54498  
[www.sheepmagazine.com](http://www.sheepmagazine.com)  
\$21 per year (6 issues)

### The Shepherd

5696 Johnston  
New Washington, OH 44854-9736  
419-492-2364  
\$30 per year (12 issues)

### Meat Goat Monthly

Ranch Publishing  
P.O. Box 2678  
San Angelo, TX 76902  
915-655-4434  
[www.ranchmagazine.com/mgn.html](http://www.ranchmagazine.com/mgn.html)  
\$27 per year (12 issues)

### The Stockman Grass Farmer

P.O. Box 2300  
Ridgeland, MS 39158-2300  
601-853-1861  
[www.stockmangrassfarmer.net](http://www.stockmangrassfarmer.net)  
\$32 per year (12 issues)

### Hobby Farms

P.O. Box 8237  
Lexington, KY 40533  
888-245-3699 (toll free)  
[www.hobbyfarms.com/publications.aspx](http://www.hobbyfarms.com/publications.aspx)  
\$15 per year (6 issues)

### Small Farm Today

3903 W. Ridge Trail Road  
Clark, MO 65243-9525  
800-633-2535 (toll-free)  
[www.smallfarmtoday.com](http://www.smallfarmtoday.com)  
\$24 per year (6 issues)

### Spin Off

Interweave Press  
201 E. Fourth Street  
Loveland, CO 80537-5655  
[www.interweave.com](http://www.interweave.com)  
\$26 per year (4 issues)

### Dairy Goat Journal

W11564 Hwy 64  
Withee, WI 54498  
[www.dairygoatjournal.com](http://www.dairygoatjournal.com)  
\$21 per year (6 issues); \$35.00 for 2 years

### Countryside & Small Stock Journal

W11564 Hwy 64  
Withee, WI 54489  
800-551-5691  
[www.countrysidemag.com](http://www.countrysidemag.com)  
\$18 per year (6 issues)

### United Caprine News

P.O. Box 328  
Crowley, TX 76036  
817-297-3411  
[www.unitedcaprinenews.com](http://www.unitedcaprinenews.com)  
\$22.50 per year (12 issues)

### Graze

P.O. Box 48  
Belleville, WI 53508  
608-455-3311  
[www.grazeonline.com](http://www.grazeonline.com)  
\$30 per year (10 issues)



## **Wild Fibers Magazine**

P.O. Box 1752  
Rockland, ME 04841  
207-594-9455  
[www.wildfibersmagazine.com](http://www.wildfibersmagazine.com)  
\$30 per year (4 issues)

## **Organizations**

### **Dairy Sheep Association of North America (DSANA)**

President, Claire M. Sandrock  
University of Wisconsin-Madison  
1675 Observatory Drive  
Madison, WI 53706  
608-332-2889  
[mikolayunas@wisc.edu](mailto:mikolayunas@wisc.edu)  
[www.dsana.org](http://www.dsana.org)

### **American Dairy Goat Association**

209 West Main Street  
P.O. Box 865  
Spindale, NC 28160  
828-286-3801  
[www.adga.org](http://www.adga.org)

### **International Goat Association**

HPI/IGA  
1 World Avenue  
Little Rock, AR 72202  
501-454-1641  
[goats@heifer.org](mailto:goats@heifer.org)  
[www.iga-goatworld.org](http://www.iga-goatworld.org)

### **American Sheep Industry Association**

6911 S. Yosemite St.  
Englewood, CO 80112-1414  
303-771-3500  
[www.sheepusa.org](http://www.sheepusa.org)

### **National Sheep Improvement Program**

James Morgan, PhD.  
479-444-6075  
[info@nsip.org](mailto:info@nsip.org)  
[www.nsip.org](http://www.nsip.org)

### **American Sheep and Goat Center**

Box 646  
Rockland, ME 04841  
800-971-1373  
[www.sheepandgoatsusa.org](http://www.sheepandgoatsusa.org)

### **American Goat Federation**

[www.americangoatfederation.org](http://www.americangoatfederation.org)  
801-376-4685 or 502-352-2434

## **Vendors: Suppliers**

### **Caprine Supply**

P.O. Box Y  
3301 W. 83rd Street  
DeSoto, KS 66018  
913-585-1191  
800-646-7736 (toll-free)  
[www.caprinesupply.com](http://www.caprinesupply.com)

### **Hoegger Supply Company**

160 Providence Road  
Fayetteville, GA 30215  
800-221-4628 (toll-free)  
[www.hoeggergoatsupply.com](http://www.hoeggergoatsupply.com)

### **Sydell**

46935 SD Hwy. 50  
Burbank, SD 57010-9605  
605-624-4538  
800-842-1369 (toll-free)  
605-624-3233 (FAX)  
[www.sydell.com](http://www.sydell.com)

### **Hamby Dairy Supply**

2402 SW Water Street  
Maysville, MO 64469-9102  
800-306-8937 (toll-free)  
[www.hambydairysource.com](http://www.hambydairysource.com)

### **Tarter Farm and Ranch Equipment**

P.O. Box 10  
Dunnville, KY 42528  
[www.tartergate.com](http://www.tartergate.com)

### **NASCO**

901 Janesville Avenue  
P.O. Box 901  
Fort Atkinson, WI 53538-0901  
800-558-9595 (toll-free)  
[www.enasco.com](http://www.enasco.com)

### **Jeffers Livestock Supply**

P.O. Box 100  
Dothan, AL 36302  
800-JEFFERS or 800-533-3377 (toll free)  
334-793-6257  
334-793-5179 FAX  
[www.jefferslivestock.com](http://www.jefferslivestock.com)  
[customerservice@jefferspet.com](mailto:customerservice@jefferspet.com)

### **Premier**

800-282-6631 (toll-free)  
[www.premier1supplies.com](http://www.premier1supplies.com)

**Pipestone Veterinary Supply**

P.O. Box 188  
1300 Hwy 75 S.  
Pipestone, MN 56164  
800-658-2523 (toll-free)  
[www.pipevet.com](http://www.pipevet.com)

**Ketcham's Sheep Equipment ("Red Stuff")**

6471 Miller Drive  
Edwardsville, IL 62025  
618-656-5388  
[www.ketchamssheepequipment.com](http://www.ketchamssheepequipment.com)

**Ketchum Manufacturing Inc.**

1245 California Ave.  
Brockville, ON, Canada  
K6V 7N5  
613-342-8455  
613-342-7550 (FAX)  
[ketchum@sympatico.ca](mailto:ketchum@sympatico.ca)  
[www.ketchum.ca](http://www.ketchum.ca)

**Gallagher Animal Management Systems**

Gallagher Power Fence, Inc.  
130 W. 23rd Ave.  
P.O. Box 7506  
North Kansas City, MO 64116  
800-531-5908 (toll-free)  
816-421-2005  
816-421-2009 (FAX)  
[www.gallagherusa.com](http://www.gallagherusa.com)

**Registers Sheep and Goat Supplies**

3398 Gabe Smith Road  
Wade, NC 28395  
1-888-310-9606  
[www.goatsupplies.netfirms.com](http://www.goatsupplies.netfirms.com)

**Sheepman Supply Co.**

8102 Liberty Road  
Frederick, MD 21701  
301-662-4197  
[www.sheepman.com](http://www.sheepman.com)

**Publishers**

Books are available at your bookstore, farm store, or directly from the publishing company.

**Storey Publishing**

MoCA Way  
North Adams, MA 01247  
413-346-2100  
413-346-2199 (FAX)  
[webmaster@storey.com](mailto:webmaster@storey.com)  
consumer orders:  
800-441-5700  
[www.storey.com](http://www.storey.com)

**Barron's Books**

250 Wireless Blvd  
Hauppauge, NY 11788  
800-645-3476  
[www.barronseduc.com](http://www.barronseduc.com)

**Back 40 Books**

Nature's Pace Sanctuary  
Hartshorn, MO 65479  
[CustomerService@Back40Books.com](mailto:CustomerService@Back40Books.com)  
[www.back40books.com](http://www.back40books.com)

**Acres USA**

P.O. Box 91299  
Austin, TX 78709  
800-355-5313  
[www.acresusa.com](http://www.acresusa.com)

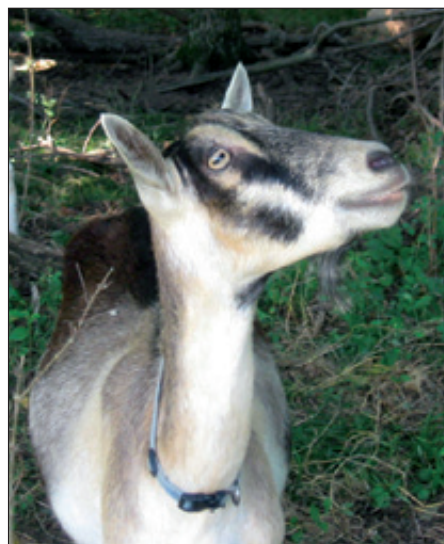

**Small Ruminant Sustainability Checksheet**

By Linda Coffey, Jana Reynolds and Margo Hale, NCAT  
Agriculture Specialists

Updated by Linda  
Coffey, Margo Hale and Hannah Lewis, NCAT Agriculture  
Specialists

© 2010 NCAT

Paul Williams, Editor  
Robyn Metzger, Production

This publication is available on the Web at:  
[www.attra.ncat.org/attra-pub/ruminantcheck.html](http://www.attra.ncat.org/attra-pub/ruminantcheck.html)  
or  
[www.attra.ncat.org/attra-pub/PDF/ruminantcheck.pdf](http://www.attra.ncat.org/attra-pub/PDF/ruminantcheck.pdf)

IP254  
Slot 255  
Version 090910

# Small Ruminant Resources

By Linda Coffey, Jana Reynolds and Margo Hale, NCAT Agriculture Specialists

Updated by Linda Coffey, Margo Hale and Hannah Lewis, NCAT Agriculture Specialists  
 © 2010 NCAT

## Contents

Types of Resources .....	1
I. General: Sheep and Goats .....	1
II. General: Sheep .....	2
III. General: Goats .....	4
IV. Forages .....	7
V. Animal Health .....	9
VI. Marketing and Business .....	12
VII. Organic Production .....	14
Vendors: Magazines ....	15
Organizations .....	16
Vendors: Suppliers .....	16
Publishers .....	17

The National Sustainable Agriculture Information Service, ATTRA ([www.attra.ncat.org](http://www.attra.ncat.org)), was developed and is managed by the National Center for Appropriate Technology (NCAT). The project is funded through a cooperative agreement with the United States Department of Agriculture's Rural Business-Cooperative Service. Visit the NCAT website ([www.ncat.org/sarc\\_current.php](http://www.ncat.org/sarc_current.php)) for more information on our other sustainable agriculture and energy projects.



Following are many sources of information helpful to producers of small ruminants. Further resources may be available at your county Extension office, through your state land-grant university, or your local library.



## Types of Resources

### ATTRA Publications

ATTRA publications are available at no cost and may be requested by calling 800-346-9140. You may also download publications at our Web site: [www.attra.ncat.org](http://www.attra.ncat.org).

### Books

The books listed offer useful information on a wide variety of production and marketing issues. These titles may be available at your local library or through inter-library loan. Most of these books will be worthwhile purchases for those new to sheep or goat production. Previewing the books at a library is the best way to select the titles that will be most useful to you.

Used copies may be available through on-line services or through other booksellers. Many suppliers of sheep and goat equipment also offer books in their catalogs, and titles are available from the publishers as well.

### Web sites

This is not intended to be a comprehensive list, but these Web sites offer convenient access to a lot of information. Web sites frequently change; please let us know if a link does not work so we can keep this list current. Call 800-346-9140 to report any problems with this list.

### Other resources

Included here are DVDs and other useful tools that do not fit into the above categories.

A sampling of magazines, organizations, suppliers, and publishers is listed at the end of the document. Listing does not imply endorsement.

Resources are numbered to help users of ATTRA's *Small Ruminant Sustainability Checksheet* locate relevant information for improving their farms. This list works in tandem with the Farm Action Plan included in that document.

## I. General: Sheep and Goats

### 1) An Illustrated Guide to Sheep and Goat Production

*This basic and heavily illustrated introduction to sheep and goat production discusses animal selection, feeding, breeding and young stock, equipment and handling, and marketing.*

## 2) Small Ruminant Sustainability Checksheet

*This checksheet is designed to stimulate critical thinking when evaluating a farm that produces sheep or goats. The sustainability of a farm depends on many factors involving farm management, use of resources, and quality of life. The questions in the checksheet are intended to stimulate awareness rather than to rate management practices. Use this guide to define areas in your farm management that might be improved, as well as to identify areas of strength.*

## 3) Small-Scale Livestock Farming: A Grass Based Approach for Health, Sustainability, and Profit

Ekarius, Carol. 1999. Storey Books, Pownal, VT. 217 p.

*Not specific to any species of livestock; contains farmer profiles and quite a bit of holistic planning and economic information. Very complete in treatment of rotational grazing.*

## 4) Sheep Housing and Equipment Handbook

Hirning, Harvey J., Tim C. Faller, Karl J. Hoppe, Dan J. Nudell, and Gary E. Ricketts. 1994. MidWest Plan Service, Ames, IA. 90 p.

*These plans are also useful for goats, and include a few plans specific to goats.*

## 5) USDA

[www.usda.gov](http://www.usda.gov)

To go directly to the sheep and goat information, use this link: [http://riley.nal.usda.gov/nal\\_display/index.php?info\\_center=8&tax\\_level=2&tax\\_subject=10&topic\\_id=1735](http://riley.nal.usda.gov/nal_display/index.php?info_center=8&tax_level=2&tax_subject=10&topic_id=1735)

## 6) NRCS

[www.nrcs.usda.gov](http://www.nrcs.usda.gov)

## 7) ATTRA—National Sustainable Agriculture Information Service

[www.attra.ncat.org](http://www.attra.ncat.org)

## 8) Maryland Small Ruminant Page

[www.sheepandgoat.com](http://www.sheepandgoat.com)

*Don't miss this site. It is the most comprehensive and easy-to-use site for sheep and goat producers, and links to many of the Web resources listed in this document. The site is so extensive that using the search function is recommended; otherwise, it might take several clicks to find what you are looking for. The home page alone contains a wealth of information, including links to PowerPoints and spreadsheets, the Sheep 101 and Sheep 201 courses, the Wild and Woolly Sheep and Goat Newsletter, a reference list that includes many fine books and tabs to many useful articles covering every conceivable aspect of sheep and goat production. This portal is run by Susan Schoenian, University of Maryland Extension, and it is the first place to go if you have Web access. Her work is top-notch. The site includes numerous resources not contained in this ATTRA resource list.*

## 9) Kentucky Sheep and Goat Development Office

[www.kysheepandgoat.org](http://www.kysheepandgoat.org)

## 10) Sheep and Goat Extension and Research, Texas A&M University

<http://animalscience.tamu.edu/academics/sheep-goats/index.htm>

## 11) Sheep and Goats, Virginia Polytechnic Institute and State University Extension

<http://pubs.ext.vt.edu/category/sheep-goats.html>

## II. General: Sheep

### 12) Dairy Sheep

*This publication offers additional information and resources and includes a quick overview of production considerations.*

### 13) Sheep: Sustainable and Organic Production

*This publication takes a look at breed selection, feeding, health management, and innovative marketing of meat and wool products.*

**14) Storey's Guide to Raising Sheep: Fourth Edition**

Simmons, Paula and Carol Ekarius. 2009. Storey Publishing, LLC., Pownal, VT. 400 p.

*This book is a very useful resource covering many aspects of raising and marketing sheep and their products. Enjoyable to read and helpful to both beginners and experienced producers.*

**15) Storey's Barn Guide to Sheep**

Burns, Deborah, Sarah Guaro and Dale Perkins, editors. 2006. Storey Publishing, LLC. Pownal, VT. 96 p.

*This spiral-bound book with large, heavy-duty pages is designed to accompany the farmer to the barn and is complete with step-by-step guides and many straightforward illustrations. A companion to Storey's Guide to Raising Sheep.*

**16) Practical Lambing and Lamb Care: Third Edition**

Eales, Andrew, John Small and Colin Macaldowie. 3rd Edition. 2004. Blackwell Publishing, Ltd., Oxford, U.K. 272 p.

*This book provides practical guidance on all aspects of lambing and lamb care, including preventing and dealing with health issues, and ewe care.*

**17) Managing Your Ewe**

Lawson, Laura. 1997. LDF Publications, Culpeper, VA. 352 p.

*Information on preparation for breeding, lambing, and aftercare.*

**18) Changes in the Sheep Industry**

National Research Council. 2008. The National Academic Press, Washington, D.C. 347 p.

*A comprehensive report covering the history and current state of the U.S. sheep industry. Also includes information on breeds, health issues, and marketing.*

**19) Sheep Success**

Griffith, Nathan. 2000. Cobblemead Publications, Trout, WV. 204 p.

*Long-established but not widely known strategies for breeding, growing, and selling sheep.*

**20) Sheep Production Handbook**

*This reference handbook, covering the basics of sheep production, is for beginning and experienced sheep producers alike.*

American Sheep Industry Association  
9785 Maroon Circle, Suite 360  
Englewood, CO 80112  
303-771-3500, ext. 32  
[www.sheepusa.org](http://www.sheepusa.org)

**21) American Sheep Industry Association**

[www.sheepusa.org](http://www.sheepusa.org)

**22) Hair Sheep Research and Information**

[www.sheepandgoat.com/HairSheepWorkshop/index.html](http://www.sheepandgoat.com/HairSheepWorkshop/index.html)

**23) National Sheep Improvement Program**

[www.nsip.org](http://www.nsip.org)

**24) Oregon State University**

<http://ans.oregonstate.edu/extension/sheep/index.htm>

**25) Penn State Sheep Publications**

<http://pubs.cas.psu.edu/PubTitle.asp?varTitle=sheep&Submit=Go>

**26) Sheep Extension Program, Farm Flock Sheep Production Handbook, Montana State University**

<http://animalrangeextension.montana.edu/articles/sheep/handbook/handbook-TOC.htm>

**27) Sheep Information - Cornell University STAR System**

[www.ansci.cornell.edu/sheep/management/breeding/star/](http://www.ansci.cornell.edu/sheep/management/breeding/star/)

- 28) University of Kentucky Sheep Publications**  
[www.uky.edu/Agl/AnimalSciences/farm/sheeppub.htm](http://www.uky.edu/Agl/AnimalSciences/farm/sheeppub.htm)
- 29) University of Minnesota Extension Sheep Publications**  
[www.extension.umn.edu/listing.html?topic=8&subcat=79](http://www.extension.umn.edu/listing.html?topic=8&subcat=79)
- 30) University of Tennessee Sheep Extension**  
<http://animalscience.ag.utk.edu/Sheep/Publications-Sheep.html>
- 31) University of Wisconsin Sheep Extension**  
[www.ansci.wisc.edu/Extension-New%20copy/sheep/index.html](http://www.ansci.wisc.edu/Extension-New%20copy/sheep/index.html)
- 32) Sheep Management Wheel**  
[www.pipestonesheep.com/sheepmanagementwheel.html](http://www.pipestonesheep.com/sheepmanagementwheel.html)

To order a Pipestone Sheep Management Wheel, send \$10 (checks payable to Minnesota West) to:  
 Pipestone Lamb and Wool Program  
 1314 North Hiawatha  
 P. O. Box 250  
 Pipestone, MN 56164  
 or contact at:  
 Phone: 507-825-6806

*The Pipestone Sheep Management Wheel is designed to make ewe flock management decisions simple and easy. The wheel is basically a management calendar. It works by setting the date you lamb, and all the management tasks that you need to do for the ewe and her lambs for the entire year are indicated on the wheel.*

### III. General: Goats

-  **33) Meat Goats: Sustainable Production**  
*Offers information specific to meat goat production and should be read after the companion publication, Goats: Sustainable Production Overview. This document discusses selection, breeds, marketing, feeding, profitability, and other topics. It includes sample budgets, case studies of farms in Montana and Missouri, and many further resources.*
-  **34) Goats: Sustainable Production Overview**  
*Discusses considerations of raising goats on pasture, including grazing, supplemental feeding, health concerns, reproduction, and management, as well as marketing and profitability.*
-  **35) Dairy Goats: Sustainable Production**  
*This publication is intended for those interested in starting a commercial goat dairy. It discusses the five major considerations to be addressed in planning for dairy goat production: labor, sales and marketing, processing, regulations, and budgeting and economics. It includes production information specific to dairy goats, including choosing breeds and selecting stock.*
- 36) Meat Goats: Their History, Management, and Diseases**  
 Mitcham, Stephanie and Allison Mitcham. 2000. Crane Creek Publications, Sumner, IA. 264 p.  
*A well-written combination of the authors' personal experiences raising goats, veterinary knowledge (Stephanie Mitcham is a DVM), and a compilation of information from other experts in the field. Includes information about handling systems (hard to find elsewhere).*
- 37) Storey's Guide to Raising Dairy Goats**  
 (Revised and updated; originally called *Raising Milk Goats the Modern Way*)  
 Belanger, Jerry. 2001. Storey Books, Pownal, VT. 288 p.  
*Very good general information for producers of dairy goats.*
- 38) Goats and Goatkeeping**  
 Thear, Katie. 1988. Merehurst Press, London, U.K. 176 p.  
*Very interesting book for goat producers, geared for the small farm. Covers milk, meat, and fiber. Practical and concise, very similar to The New Goat Handbook, but with added detail.*

**39) The Goat Handbook**

Judas, Ulrich and Seyedemehdi Mobini. 2006. Barron's Educational Series, Inc., Hauppauge, NY. 144 p.  
*The compact size of this book makes it easy to keep handy, and it is full of photographs, line drawings, and useful information. Includes basic information on care, housing, breeding, and upkeep in non-technical language.*

**40) Goat Husbandry: Fifth Edition, revised and edited by Ruth Goodwin**

Mackenzie, David. 1993. Faber & Faber, London, U.K. 355 p.  
*British terminology, very good reading — a classic.*

**41) Angora Goats the Northern Way: Fourth Edition**

Drummond, Susan Black. 1993. Stoney Lonesome Farm, Freeport, MI. 239 p.

**42) Raising Goats for Milk and Meat: Third Edition**

Sinn, Rosalee. 2008. Heifer International, Little Rock, AR. 218 p.  
*Written for producers with limited resources, this is a very practical book, much expanded over the previous version; don't miss the chapter on health, which includes emphasis on prevention. Educators will appreciate the format of this book, in which the 10 chapters are presented as learning guides and lessons. This is an ideal course for educators working with groups and for self-study.*

**43) Your Goats: A Kid's Guide to Raising and Showing**

Damerow, Gail. 1993. Storey Books, Pownal, VT. 172 p.  
*Gail Damerow writes very good books; this one is easy to understand and very informative. Not just for kids.*

**44) Raising Meat Goats for Profit**

Bowman, Gail. 1999. Bowman Communications, Inc., Twin Falls, ID. 256 p.  
*This "how-to" book is a wonderful resource for goat breeders. It includes information about the meat breeds, how to get started with meat goat production, feed ration tables, kidding and raising kids, how to sell your goats, and information on health and diseases, as well as recipes.*

**45) Storey's Guide to Raising Meat Goats**

Sayer, Maggie. 2007. Storey Publishing, LLC., Pownal, VT. 320 p.

**46) Simply Meat Goats**

Solaiman, Sandra G. 2006. George Washington Carver Agricultural Experiment Station, Tuskegee University, Tuskegee, AL. 118 p.

**47) Oklahoma Basic Meat Goat Manual**

Oklahoma Cooperative Extension Service and Oklahoma State University. 2008. Oklahoma State Extension. 100 p.

To view online or order a copy, visit <http://meatgoat.okstate.edu> or contact JJ Jones at 580-332-7011.

**48) Meat Goat Production Handbook**

Gipson, T.A., R.C. Merkel, and S. Hart. 2008. American Institute for Goat Research, Langston, OK. 418 p.  
*Comprehensive and highly useful guide to meat goat production and marketing. See content online at [www.luresext.edu/goats/training/qa.html](http://www.luresext.edu/goats/training/qa.html) (Web-based Training and Certification Program for Meat Goat Producers). This spiral-bound book is a handy reference.*

To acquire a copy, write to

MGPH

Langston University

Box 730

Langston, OK 73050

or access the order form at [www.luresext.edu/goats/handbookorderform.pdf](http://www.luresext.edu/goats/handbookorderform.pdf). Current cost is \$50, which includes shipping and handling in the U.S.

**49) Goats: Small-scale Herding for Pleasure and Profit**

Weaver, Sue. 2006. Bow Tie Press. 160 p.  
*This introductory book discusses choosing, breeding, and tending goats.*



- 50) Nutrient Requirements of Small Ruminants: sheep, goats, cervids, and new world camelids**  
NRC. 2007. National Academy Press, Washington, DC.
- 51) A Compilation of the Wit and Wisdom of “The Goat Man”**  
Pinkerton, Frank. 2010. Published by Goat Rancher Magazine. 334 p.  
*Dr. Pinkerton has been involved in every aspect of the goat industry and he writes very well, managing to be educational and funny at the same time. This book deals with all aspects of goat production, but is especially strong in the areas of marketing of meat goats, goat enterprise economics and production testing, vital areas that are often overlooked in goat production books.*
- 52) Web-based Training and Certification Program for Meat Goat Producers**  
[www.luresext.edu/goats/training/qa.html](http://www.luresext.edu/goats/training/qa.html)
- 53) Meat Goat Home Study Course, Penn State Extension**  
<http://bedford.extension.psu.edu/agriculture/goat/Goat%20Lessons.htm>
- 54) Langston University–E (Kika) de la Garza American Institute for Goat Research**  
[www2.luresext.edu/goats/index.htm](http://www2.luresext.edu/goats/index.htm)  
*This Web site is packed with solid information for goat producers, whether they raise meat, dairy, or fiber goats. From the home page, you can connect to the Web-based training course (see 52 above), the online manual for conducting fecal egg counts, nutrient requirements calculators (for balancing rations) and more. Use the search button to find information on many goat production topics. The Web-based training course can be browsed and then read one chapter at a time; this is one of the best places to go for information on any aspect of meat goat production.*
- 55) Nutrient Requirements of Goats (1981 edition)**  
[www.nap.edu/openbook.php?record\\_id=30&page=1](http://www.nap.edu/openbook.php?record_id=30&page=1)  
*This version is very accessible and useful, but be aware that there is an updated version. See entry above in the book listings.*
- 56) North Carolina State University – Extension Animal Husbandry (see Meat Goat)**  
[www.cals.ncsu.edu/lan\\_sci/extension/animal/eahmain.html](http://www.cals.ncsu.edu/lan_sci/extension/animal/eahmain.html)
- 57) Meat Goat Selection, Carcass Evaluation, and Fabrication Guide**  
[www.lsuagcenter.com/en/crops\\_livestock/livestock/sheep\\_goats/Meat+Goat+Selection+Carcass+Evaulation+and+Fabrication.htm](http://www.lsuagcenter.com/en/crops_livestock/livestock/sheep_goats/Meat+Goat+Selection+Carcass+Evaulation+and+Fabrication.htm)
- 58) Tennessee Grazing Planner**  
[www.tn.nrcs.usda.gov/technical/grazing/docs/calendar%202008%20goats.pdf](http://www.tn.nrcs.usda.gov/technical/grazing/docs/calendar%202008%20goats.pdf)
- 59) Goat World**  
[www.goatworld.com](http://www.goatworld.com)
- 60) Boer and Meat Goat Information**  
[www.boergoats.com](http://www.boergoats.com)
- 61) Penn State Meat Goat Research and Publications**  
[www.das.psu.edu/goats/research](http://www.das.psu.edu/goats/research)
- 62) American Dairy Goat Association**  
[www.adga.org/](http://www.adga.org/)
- 63) The Dairy Goat Journal**  
[www.dairygoatjournal.com](http://www.dairygoatjournal.com)
- 64) Wisconsin Dairy Artisan Network**  
<http://wisconsinindairyartisan.org/goats.html>
- 65) Meat Goat Management Wheel**  
<http://extension.missouri.edu/publications/DisplayPub.aspx?P=MP913>

*The versatile, easy-to-use Meat Goat Management Wheel simplifies decisions about meat goat management and production. The wheel is a management calendar that helps you schedule tasks. It contains lots of general management information that can be adjusted for individual operations and different management styles.*

Order from University of Missouri Extension Publications  
<http://extension.missouri.edu/publications/>  
573-882-7216

#### **66) Meat Goat Production and Marketing DVD**

[www.ssawg.org/virtualfarm.html#goats](http://www.ssawg.org/virtualfarm.html#goats)

*This video illustrates the story of Bill Legg's pastured meat goat operation, within the setting of his diverse Tennessee farm. The practical information includes goat breeds and breeding tips, pasture management, pest control, marketing, and more – as told by the farmer.*

#### **Southern Sustainable Agriculture Working Group (SSAWG) DVD series**

*Southern SAWG's video series titled Natural Farming Systems in the South provides an easy, economical way to take a virtual tour of some highly successful farming operations in the region. Compiled in partnership with the USDA's Risk Management Agency, these broadcast-quality videos feature farmers who detail in plain-spoken terms their whole farming systems and each component unique to their particular operations.*

*Videos in the series include Meat Goat Production and Marketing, Artisan Cheese Making, and more. Visit [www.ssawg.org/virtualfarm.html](http://www.ssawg.org/virtualfarm.html) to order the videos, take virtual farm tours, download the Meat Goat Resource List, or watch short video clips. Call 479-251-8310 to order DVDs. Currently they are \$15 each (plus shipping and handling).*

## **IV. Forages**

### **67) Assessing the Pasture Soil Resource**

*How to take a soil sample and an easy way to assess soil biological activity and water infiltration. Assessment sheet included.*

### **68) Multispecies Grazing**

*Brief overview of why multispecies grazing is beneficial, as well as considerations for management.*

### **69) Paddock Design, Fencing, and Water Systems for Controlled Grazing**

*This publication covers some of the basics of paddock design and current fencing and water technology.*

### **70) Rotational Grazing**

*How to manage pastures and grazing animals to make more profitable use of a farm's resources.*

### **71) Pastures: Sustainable Management**

*This publication looks at managing fertility and pests, grazing systems, conserved forages, and maintaining productivity. It includes additional resources.*

### **72) Pasture, Rangeland, and Grazing Management**

*This publication profiles the general types of pastures and rangelands and offers information about management and expected yields. Weed management strategies are also discussed, and tips are offered to rehabilitate depleted land. Issues in grazing management, such as paddock development, plant selection, drought and plant toxicosis, are also discussed. Resources and references are also included.*

### **73) Pastures: Going Organic**

*This publication is an introduction to regulations related to organic pasture and rangeland in the United States. Fertility, weed, and insect pest management issues are briefly addressed. Organic integrity is discussed, including records required to demonstrate compliance with the National Organic Standards. References and resources follow the narrative.*

### **74) Ruminant Nutrition for Graziers**

*This publication provides managers with tools and references to assess biological and climatological variables and make decisions that ensure the ecological and economic viability of a grass-based ruminant operation.*

**75) Small-Scale Livestock Farming: A Grass Based Approach for Health, Sustainability, and Profit**

Ekarius, Carol. 1999. Storey Books, Pownal, VT. 217 p

*Not specific to any species of livestock; contains farmer profiles and quite a bit of holistic planning and economic information. Very complete in treatment of rotational grazing.*

**76) Southern Forages**

Ball, D.M., C. S. Holveland, and G.D. Lacefield. 2002. Potash & Phosphate Institute (PPI). Norcross, GA. 322 p.

*This handy book includes color photos to help in forage identification, as well as very readable and useful treatments of forage programs, options in forages, establishing forages, managing grazing, minimizing stored feed requirements, dealing with poisonous plants, and much more. A chapter on forage quality is followed by a chapter on the nutrient requirements of livestock. All graziers in the South will benefit from reading and using this book. Printed on durable enameled paper, this book is compact and includes lots of tables, graphics and photos. Softcover. "From dashboards of trucks to libraries, this book will be dog-eared from regular use." (Dr. Jimmy Henning, University of Kentucky Extension Forage Specialist)*

Order from:

Potash & Phosphate Institute (PPI)

655 Engineering Drive, Suite 110

Norcross, Georgia 30092-2837

Phone: 770-825-8082

E-mail: [circulation@ppi-far.org](mailto:circulation@ppi-far.org)

**77) Comeback Farms: Rejuvenating Soils, Pastures and Profits with Livestock Grazing Management**

Judy, Greg. 2008. Acres USA. Austin, TX. 278 p.

*This book expands on the cattle operation and includes first-hand experience with high density multi-species grazing, specifically for sheep, goats, and pigs. Tips are included on how to work with nature without costly inputs and letting the animals be your labor force.*

**78) Targeted Grazing: A Natural Approach to Vegetation Management and Landscape Enhancement**

National Sheep Industry Improvement Center and American Sheep Industry Association. 2006.

American Sheep Industry Association, Centennial, CO. 199 p.

To view online or order a copy, visit [www.cnr.uidaho.edu/rx-grazing/Handbook.htm](http://www.cnr.uidaho.edu/rx-grazing/Handbook.htm) or contact

American Sheep Industry Association

9785 Maroon Circle, Suite 360

Englewood, CO 80112

303-771-3500, ext. 32

**79) More Sheep, More Grass, More Money**

Schroedter, Peter. 1997. Ramshead Publishing, Ltd. Moosehorn, Manitoba. p.112

*Personal experiences of the author emphasizing the need to make a profit with the sheep enterprise. It includes examples of how to cut costs and increase profits. Emphasis on grazing management. Very practical.*

**80) Tennessee Grazing/Browsing Calendar**

[www.tn.nrcs.usda.gov/technical/grazing/docs/calendar%202008%20goats.pdf](http://www.tn.nrcs.usda.gov/technical/grazing/docs/calendar%202008%20goats.pdf)

*While the title indicates "2008," this calendar is useful every year as a reminder of good management practices for your pasture and goats. This tool is concise, informative, and loaded with tips to benefit your whole farm. Record sheets are included at the end of the 23-page document.*

**81) Intermountain Planting Guide**

Jensen, Kevin, and Howard Horton, Ron Reed, and Ralph Whitesides. Utah State University. 106 p.

[http://extension.usu.edu/files/publications/publication/pub\\_\\_7717229.pdf](http://extension.usu.edu/files/publications/publication/pub__7717229.pdf)

**82) Extending Grazing and Reducing Stored Feed Needs**

<http://lagebb.missouri.edu/mfgc/2009extgraz.pdf>

*This 20-page publication is ANR-1357 and is available at some Extension offices.*

- 83) **University of Wisconsin Extension Pasture Management and Grazing**  
[www2.uwrf.edu/grazing](http://www2.uwrf.edu/grazing)
- 84) **Livestock for Landscapes**  
[www.livestockforlandscapes.com](http://www.livestockforlandscapes.com)
- 85) **BEHAVE- Behavioral Education for Human Animal Vegetation and Ecosystem Management**  
[www.behave.net](http://www.behave.net)
- 86) **Alberta Forage Manual**  
[www1.agric.gov.ab.ca/\\$department/deptdocs.nsf/all/agdex16](http://www1.agric.gov.ab.ca/$department/deptdocs.nsf/all/agdex16)
- 87) **Montana State University**  
<http://www.msuextension.org/store/Departments/Agriculture-Topic-Categories/Range-Management.aspx>
- 88) **ARS Range Monitoring Manuals**  
[http://usda-ars.nmsu.edu/monit\\_assess/index.html](http://usda-ars.nmsu.edu/monit_assess/index.html)
- 89) **Interpreting Indicators of Rangeland Health**  
[ftp://ftp-fc.sc.gov.usda.gov/GLTI/technical/publications/IIRH\\_v4\\_8-15-05.pdf](ftp://ftp-fc.sc.gov.usda.gov/GLTI/technical/publications/IIRH_v4_8-15-05.pdf)
- 90) **USDA Pasture Condition Score System**  
<http://ddr.nal.usda.gov/bitstream/10113/37920/1/IND44315660.pdf>
- 91) **Guide to NRCS Pasture Condition Scoring**  
<ftp://ftp-fc.sc.gov.usda.gov/GLTI/technical/publications/pasture-score-guide.pdf>
- 92) **Pasture Condition Score Sheet**  
<ftp://ftp-fc.sc.gov.usda.gov/GLTI/technical/publications/pasture-score-sheet.pdf>
- 93) **Multi-Species Grazing and Leafy Spurge CD**  
 TEAM Leafy Spurge. 2002.  
 USDA-ARS Northern Plains  
 Agriculture Research Laboratory  
 1500 North Central Avenue  
 Sidney, MT 59270  
 406-433-2020  
[www.team.ars.usda.gov](http://www.team.ars.usda.gov)

*This CD provides a variety of useful information about using grazing as an effective, affordable, and sustainable leafy spurge management tool. It contains economic reports, posters, photos, a PowerPoint presentation, extensive bibliography, and more. A great resource.*

94) **GOATS! For Firesafe Homes in Wildland Areas CD**





Kathy Voth  
 6850 West County Road 24  
 Loveland, CO 80538  
[www.livestockforlandscapes.com](http://www.livestockforlandscapes.com)

*This CD/Handbook is designed to provide fire managers, communities, and livestock owners information on using goats to reduce fire danger. It includes expected results, and the “hows” of managing animals, choosing treatment sites, developing contracts for services, estimating costs, and starting projects. This is a great CD with some excellent videos.*

## V. Animal Health

 95) **Managing Internal Parasites in Sheep and Goats**

*This publication discusses new techniques to manage parasites and to prolong the efficacy of dewormers. New management tools that remain under investigation are also discussed. A list of resources follows the narrative.*

-  **96) Tools for Managing Internal Parasites in Small Ruminants: Copper Wire Particles**  
*This publication contains information on how to make boluses of copper wire oxide particles and reports results of studies on the effectiveness of this treatment.*
-  **97) Tools for Managing Internal Parasites in Small Ruminants: Sericea Lespedeza**  
*This publication discusses tools that can be used to manage internal parasites of sheep and goats that are becoming resistant to conventional wormers. One such tool is the forage sericea lespedeza, and the publication discusses how it can be used and presents the results of research on how it reduces parasites in small ruminants.*
-  **98) Predator Control for Sustainable and Organic Livestock Production**  
*This publication focuses primarily on the control of coyotes and dogs, the main causes of livestock loss to predation, through management practices such as fencing and secure areas and the use of guard animals.*
-  **99) Integrated Parasite Management for Livestock**  
*With parasites developing resistance to all dewormers, and more farmers producing livestock by “natural” methods, there is interest in looking for alternative ways to manage parasite problems. This publication offers a systems approach to assess and manage the soil, forages, and animals to decrease internal parasites and their effects.*
- 100) Sheep and Goat Medicine**  
 Pugh, D.G. 2002. W.B. Saunders Company, Philadelphia, PA. 468 p.  
*A great gift for a veterinarian. A wealth of information for producers and for veterinarians. Knowledge of veterinary terminology will be helpful in using this book.*
- 101) A Veterinary Guide for Animal Owners: Second Edition**  
 Spaulding, C.E and Jackie Clay. 2nd Edition. 2001. Rodale, Inc., Emmaus, PA. 432 p.  
*A very readable and practical book with chapters on cattle, horses, hogs, sheep, goats, dogs and cats.*
- 102) Keeping Livestock Healthy: Fourth Edition**  
 Haynes, N. Bruce. 2001. Storey Publishing, LLC., Pownal, VT. 352 p.  
*Covers cattle, horses, swine, sheep, and goats. A good book for learning about diseases in general, with emphasis on prevention. Most attention is given to large animals.*
- 103) ...May Safely Graze: Protecting Livestock Against Predators**  
 Fytche, Eugene. 1998. Published by the author. 103 p.  
 Available from:  
 Eugene Fytche  
 R.R. #1  
 Almonte, Ontario. K0A 1A0.  
*This book explores how to identify and quantify the predator problem and includes information on many methods to control the predators, including guard animals, fencing, and management.*
- 104) Livestock Guardians: Using Dogs, Donkeys, and Llamas to Protect your Herd**  
 Dohner, Jan Vorwald. 2007. Storey Publishing, LLC., Pownal, VT. 256 p.  
*A comprehensive guide for farmers struggling to reduce predation of sheep, goats, and other livestock.*
- 105) The Complete Herbal Handbook for Farm and Stable: Fourth Edition**  
 Bairaclı Levy, Juliette de. 1991. Faber & Faber, London, U.K. 471 p.  
*Very interesting book offering a different perspective on prevention of disease and production of healthy animals without using conventional medicine.*

**106) The Dairy Practices Council Small Ruminant Guidelines**

Guidelines for the Dairy Industry Relating to Sanitation and Milk Quality for Small Ruminant Operations.

The Dairy Practices Council  
51 East Front Street, Suite 2  
Keyport, NJ 07735  
732-264-2643  
[www.dairyperc.org](http://www.dairyperc.org)  
Set: \$70.00.

*A set of 17 Guidelines relating to small ruminants; each may also be purchased separately. Very good technical information for commercial producers of dairy sheep and goats.*

**107) Humane Livestock Handling**

Grandin, Temple. 2008. Storey Publishing, Pownal, VT. 227 p.

*Learn how to improve the day-to-day operation as well as the profitability of your farm by raising healthier, more contented animals. Temple Grandin shares dozens of methods and detailed plans she has developed for low-stress ways to move livestock on pastures, paddocks, and feedlot pens.*

**108) Small Ruminant Production Medicine and Management Manual**

P.O. Box 494  
Brigham City, UT 84302  
877-424-7838  
[Infovets.com](http://Infovets.com)

*This reference manual contains video, flow charts, photos, and procedure descriptions that are a must for any sheep and goat owner. Find answers to those everyday questions on management, birthing problems, disease prevention/treatment, the proper use of various products, and much more.*

**109) Alternative Treatments for Ruminant Animals**

Dettloff, Paul, DVM. 2004. Acres USA. Austin, TX. 246 p.

[www.acresusa.com/books/closeup.asp?prodid=1236&catid=11&pcid=2](http://www.acresusa.com/books/closeup.asp?prodid=1236&catid=11&pcid=2)

*This book provides information on natural, organic, and sustainable approaches to animal health. Includes information for sheep and goats.*

**110) Natural Goat Care**

Coleby, Pat. 2001. Acres USA. Austin, TX. 371 p.

*Fascinating book; Australian author pays much attention to nutrition and to maintaining health organically. Call 1-800-355-5313.*

**111) Goat Medicine, Second Edition**

Smith, Mary and David M. Sherman. 2009. Wiley-Blackwell, Baltimore, MD. 888 p.

*This book is recommended as a useful gift for a veterinarian. Very scientific; some of the terminology will be understood only by a veterinarian, but a few chapters are very useful to producers.*

**112) Goat Health Handbook: A Field Guide for Producers with Limited Veterinary Service**

Theford, T.R. 1983. Printed in collaboration with the Agricultural Experimental Station, University of Arkansas. 123 p.

Available from:  
International Winrock Publication Sales  
P.O. Box 9363  
Arlington, VA 22209-0363

**113) Natural Sheep Care**

Coleby, Pat. 2006. Acres USA, Austin, TX. 215 p.

*This is a natural sheep care book with special attention devoted to breeding for finer wool and meat, land management, and treatment of diseases and other health problems.*

**114) Living With Worms in Organic Sheep Production**

Stockdale, Peter. 2008. Canadian Organic Growers, Inc., Ontario, Canada. 79 p  
*An excellent book that covers parasite life cycles, managing pastures and animals to prevent parasitism, and diagnosis and treatment of internal parasites.*

**115) The Sheep Keeper's Veterinary Handbook**

Winter, Agnes and Judith Charnley. 2007. The Crowood Press, Ltd., Ramsbury, Marlborough, U.K. 208 p.  
*Covers the basics of keeping sheep and common health issues. Focuses on identifying healthy sheep and preventing disease.*

**116) American Association of Small Ruminant Practitioners**

[www.aasrp.org](http://www.aasrp.org)

**117) National Scrapie Education Initiative**

[www.eradicatescrapie.org](http://www.eradicatescrapie.org)

**118) Southern Consortium for Small Ruminant Parasite Control**

[www.scsrpc.org](http://www.scsrpc.org)

**119) Pipestone Veterinary Supply**

[www.pipevet.com](http://www.pipevet.com)

## VI. Marketing and Business

 **120) Direct Marketing**

*This publication on direct marketing alternatives—with emphasis on niche, specialty, and value-added products—features many farm case studies, as well as information on enterprise budgets and promotion/publicity. A new section discusses implications of Internet marketing and e-commerce for agriculture.*

 **121) Evaluating a Rural Enterprise**

*This publication is for people who already live in rural areas and want to add new enterprises to their operations. Its sections guide the reader in evaluating resources, assessing finances, gathering information, and marketing. It also discusses choosing an “alternative” enterprise and offers further resources.*

 **122) Holistic Management**

*Introduction to holistic management. Holistic management is a decision-making framework that assists farmers and others in establishing a long-term goal, a detailed financial plan, a biological plan for the landscape, and a monitoring program to assess progress toward the goal. Holistic Management helps managers ask the right questions and guides them in setting priorities.*

 **123) Keys to Success in Value-Added Agriculture**

*This publication presents, largely in the words of fourteen farmers, important lessons they learned in adding value to farm products and marketing directly to consumers.*

 **124) Overview: Adding Value to Farm Products**

*This publication introduces the concept of value-added farm products, explains a few of the nuts and bolts for starting a food processing business, and provides resources for additional information.*

 **125) Value-Added Dairy Options**

*Considerations for those who want to increase profitability by bottling milk, making cheese or yogurt, or doing some other processing of their milk. This publication discusses regulations and organic milk certification and offers resources for further information.*

**126) Building a Sustainable Business: A Guide to Developing a Business Plan for Farms and Rural Business**

DiGiacomo, Gigi, Robert King, and Dale Nordquist. 2003. Minnesota Institute for Sustainable Agriculture, Saint Paul, MN, and the Sustainable Agriculture Network, Beltsville, MD. 280 p.

*Business planning is an important part of owning and managing a farm. Business plans help farmers demonstrate that they have fully researched their proposed enterprises; they know how to produce their*

products, how to sell what they produce, and how to manage financial risks. This comprehensive workbook will guide farmers through every step of the process in creating a business plan. Includes many examples from existing farms. This workbook is a bargain. Available for \$14.00 + \$3.95 S/H by calling 802-656-0484 or 800-909-6472. Publication can also be viewed and downloaded at <http://www.misa.umn.edu/vd/bizplan.html>.

**127) Small-Scale Livestock Farming: A Grass Based Approach for Health, Sustainability, and Profit**

Ekarius, Carol. 1999. Storey Books, Pownal, VT. 217 p.

*Not specific to any species of livestock; contains farmer profiles and quite a bit of holistic planning and economic information. Very complete in treatment of rotational grazing.*

**128) Making Money with Goats**

Winslow, Ellie. 2005. Freefall Press. 193 p.

*This book covers many ways to make money with goats, including information on general production, goat milk, meat, skins, fiber, and business planning.*

**129) Turning Wool into a Cottage Industry**

Simmons, Paula. 1991. Storey Books, Pownal, VT. 188 p.

*This book is a big help to those who want to use fiber.*

**130) Changes in the Sheep Industry**

National Research Council. 2008. The National Academic Press, Washington, D.C. 347 p.

*A comprehensive report covering the history and current state of the U.S. sheep industry. Also includes information on breeds, health issues, and marketing.*

**131) Marketing out of the Mainstream: A producers' guide to direct marketing of lamb and wool**

Kirkpatrick, Tamra and James Bell. 1995. Sheep Industry Development Program. Englewood, CO. 57 p.

*Available as a PDF from the American Sheep Industry Web site. See [www.sheepusa.org/Publications](http://www.sheepusa.org/Publications). This site also includes up-to-date reports about marketing, and the Sheep Care Guide.*

**132) Holistic Management: A New Framework for Decision Making**

Savory, Allan, and Jody Butterfield. 1999. Island Press, Washington, D.C. 616 p

*This is an in-depth look at how to assess your situation, form a mission statement, set goal,s and make plans to reach them in light of social, economic, and environmental concerns. While it is very long and introduces some difficult concepts and unfamiliar terminology, this book includes pictures, graphics, examples, and clear explanations. Understanding and applying the concepts of holistic management will lead to making better decisions for your land and your family.*

**133) Whole Farm Planning: Ecological Imperatives, Personal Values and Economics**

Henderson, Elizabeth, and Karl North. 2004. Northeast Organic Farming Association Interstate Council. Barre, MA. 92 p.

[www.nofa.org](http://www.nofa.org)

*Concise, simplified, unintimidating look at whole farm planning, packed with examples. This is a great place to start learning about holistic management.*

**134) Sheep and Goat Marketing Information**

<http://sheepgoatmarketing.info>

**135) Measuring and Analyzing Farm Financial Performance, Purdue Extension**

[www.agecon.purdue.edu/extension/programs/fbm21/Ec712entry.htm](http://www.agecon.purdue.edu/extension/programs/fbm21/Ec712entry.htm)

**136) A PRIMER for Selecting New Enterprises for Your Farm, University of Kentucky Extension**

[www.uky.edu/AglAgEcon/pubs/ext\\_aec/ext2000-13.pdf](http://www.uky.edu/AglAgEcon/pubs/ext_aec/ext2000-13.pdf)

**137) Holistic Management**









<http://holisticmanagement.org>

**138) Whole Farm Planning With Holistic Management**

[www.umass.edu/umext/jgerber/hmpage/hmpage2/mainpage6.htm](http://www.umass.edu/umext/jgerber/hmpage/hmpage2/mainpage6.htm)



## VII. Organic Production

-  **139) NCAT's Organic Livestock Workbook**  
*This workbook has been created to help organic and transitional producers with livestock or mixed crop and livestock operations understand the range of practices and materials allowed under the National Organic Program Regulations. Particular emphasis is placed on farming strategies and practices that promote sustainability.*
-  **140) Pastures: Going Organic**  
*This publication is an introduction to regulations related to organic pasture and rangeland in the United States. Fertility, weed, and insect pest management issues are briefly addressed. Organic integrity is discussed, including records required to demonstrate compliance with the National Organic Standards. References and resources follow the narrative.*
-  **141) Organic Standards for All Organic Operations: Highlights of the USDA's National Organic Program Regulations**  
*This collection of excerpts from the USDA's National Organic Program (NOP) Final Rule provides the reader with key standards relevant to all certified organic operations.*
-  **142) Organic Standards for Livestock Production: Highlights of the USDA's National Organic Program Regulations**  
*This collection of excerpts from the U.S. Department of Agriculture's National Organic Program (NOP) provides the reader with key standards relevant to organic livestock producers.*
-  **143) Organic Certification Process**  
*This guide is designed to help organic producers and handlers understand, prepare for, and get the most from the process of organic certification to USDA National Organic Standards.*
-  **144) Organic Farm Certification and the National Organic Program**  
*Farmers planning to market their products as "organic" must become certified. This guide outlines the considerations involved in "going organic" and the basic steps to organic certification.*
-  **145) Organic System Plans: Livestock Production**  
*If you want to certify your livestock operation(s) as organic, you will need to complete an application form. This guide was developed to assist you in completing that application by explaining just what information certifiers want and why it is required.*
-  **146) Organic Livestock Documentation Forms**  
*In order to become certified organic, livestock producers must demonstrate to an accredited certifier that their operations comply with National Organic Program regulations. The 32 forms in this package are provided as tools that livestock producers can use for documenting practices, inputs, and activities that demonstrate compliance with regulations or that assist in other aspects of farm record keeping.*
-  **147) Organic Livestock Feed Suppliers Database**  
*One of the challenges of organic livestock production is locating the 100% organic feed required. This self-listing database helps producers locate sources of feed. Only available online at [http://attra.ncat.org/attra-pub/livestock\\_feed/](http://attra.ncat.org/attra-pub/livestock_feed/).*
- 148) Alternative Treatments for Ruminant Animals**  
Dettloff, Paul, DVM. 2004. Acres USA. Austin, TX. 246 p.  
[www.acresusa.com/books/closeup.asp?prodid=1236&catid=11&pcid=2](http://www.acresusa.com/books/closeup.asp?prodid=1236&catid=11&pcid=2)  
*This book provides information on natural, organic, and sustainable approaches to animal health. Includes information for sheep and goats.*
- 149) Living With Worms in Organic Sheep Production**  
Stockdale, Peter. 2008. Canadian Organic Growers, Inc., Ontario, Canada. 79 p.  
*An excellent book that covers parasite life cycles, managing pastures and animals to prevent parasitism, diagnosis and treatment of internal parasites.*

### 150) Transitioning to Organic Sheep or Goat Meat Production

<http://mosesorganic.org/attachments/productioninfo/fstransgsmeat.html>

### 151) Transitioning to Organic Sheep or Goat Dairy Production

<http://mosesorganic.org/attachments/productioninfo/fstransgsdairy.html>

### 152) National Organic Program

*Home page:* [www.ams.usda.gov/AMSv1.0/nop](http://www.ams.usda.gov/AMSv1.0/nop)

*Link to standards:* <http://ecfr.gpoaccess.gov/cgi/t/text/text-idx?c=ecfr&sid=89916dd414d154b401d29376f730a9b7&rgn=div5&view=text&node=7:3.1.1.9.32&idno=7>

*List of certifiers:* [www.ams.usda.gov/AMSv1.0/getfile?dDocName=STELPRDC507448](http://www.ams.usda.gov/AMSv1.0/getfile?dDocName=STELPRDC507448)

### 153) New Farm (Rodale)

*Home page:* [www.rodaleinstitute.org/new\\_farm](http://www.rodaleinstitute.org/new_farm)

*Certifier directory:* [www.rodaleinstitute.org/certifier\\_directory](http://www.rodaleinstitute.org/certifier_directory)

### 154) Organic Trade Association Organic Pages Online

[www.theorganicpages.com/topol/index.html](http://www.theorganicpages.com/topol/index.html)

## Vendors: Magazines

### Goat Rancher

Terry Hankins, editor and publisher

731 Sandy Branch Road

Sarah, MS 38665

888-562-9529

[www.goatrancher.com](http://www.goatrancher.com)

\$29 per year (12 issues)

### Sheep! Magazine

W11564 Hwy. 64

Withee, WI 54498

[www.sheepmagazine.com](http://www.sheepmagazine.com)

\$21 per year (6 issues)

### The Shepherd

5696 Johnston

New Washington, OH 44854-9736

419-492-2364

\$30 per year (12 issues)

### Meat Goat Monthly

Ranch Publishing

P.O. Box 2678

San Angelo, TX 76902

915-655-4434

[www.ranchmagazine.com/mgn.html](http://www.ranchmagazine.com/mgn.html)

\$27 per year (12 issues)

### The Stockman Grass Farmer

P.O. Box 2300

Ridgeland, MS 39158-2300

601-853-1861

[www.stockmangrassfarmer.net](http://www.stockmangrassfarmer.net)

\$32 per year (12 issues)

### Hobby Farms

P.O. Box 8237

Lexington, KY 40533

888-245-3699 (toll free)

[www.hobbyfarms.com/publications.aspx](http://www.hobbyfarms.com/publications.aspx)

\$15 per year (6 issues)

### Small Farm Today

3903 W. Ridge Trail Road

Clark, MO 65243-9525

800-633-2535 (toll-free)

[www.smallfarmtoday.com](http://www.smallfarmtoday.com)

\$24 per year (6 issues)

### Spin Off

Interweave Press

201 E. Fourth Street

Loveland, CO 80537-5655

[www.interweave.com](http://www.interweave.com)

\$26 per year (4 issues)

### Dairy Goat Journal

W11564 Hwy 64

Withee, WI 54498

[www.dairygoatjournal.com](http://www.dairygoatjournal.com)

\$21 per year (6 issues); \$35.00 for 2 years

### Countryside & Small Stock Journal

W11564 Hwy 64

Withee, WI 54489

800-551-5691

[www.countrysidemag.com](http://www.countrysidemag.com)

\$18 per year (6 issues)

**United Caprine News**  
P.O. Box 328  
Crowley, TX 76036  
817-297-3411  
[www.unitedcaprinenews.com](http://www.unitedcaprinenews.com)  
\$22.50 per year (12 issues)

**Graze**  
P.O. Box 48  
Belleville, WI 53508  
608-455-3311  
[www.grazeonline.com](http://www.grazeonline.com)  
\$30 per year (10 issues)

**Wild Fibers Magazine**  
P.O. Box 1752  
Rockland, ME 04841  
207-594-9455  
[www.wildfibersmagazine.com](http://www.wildfibersmagazine.com)  
\$30 per year (4 issues)

## Organizations

**Dairy Sheep Association of North America (DSANA)**  
President, Claire M. Sandrock  
University of Wisconsin-Madison  
1675 Observatory Drive  
Madison, WI 53706  
608-332-2889  
[mikolayunas@wisc.edu](mailto:mikolayunas@wisc.edu)  
[www.dsana.org](http://www.dsana.org)

**American Dairy Goat Association**  
209 West Main Street  
P.O. Box 865  
Spindale, NC 28160  
828-286-3801  
[www.adga.org](http://www.adga.org)

**International Goat Association**  
HPI/IGA  
1 World Avenue  
Little Rock, AR 72202  
501-454-1641  
[goats@heifer.org](mailto:goats@heifer.org)  
[www.iga-goatworld.org](http://www.iga-goatworld.org)

**American Sheep Industry Association**  
6911 S. Yosemite St.  
Englewood, CO 80112-1414  
303-771-3500  
[www.sheepusa.org](http://www.sheepusa.org)

**National Sheep Improvement Program**  
James Morgan, PhD.  
479-444-6075  
[info@nsip.org](mailto:info@nsip.org)  
[www.nsip.org](http://www.nsip.org)

**American Sheep and Goat Center**  
Box 646  
Rockland, ME 04841  
800-971-1373  
[www.sheepandgoatsusa.org](http://www.sheepandgoatsusa.org)

**American Goat Federation**  
[www.americangoatfederation.org](http://www.americangoatfederation.org)  
801-376-4685 or 502-352-2434

## Vendors: Suppliers

**Caprine Supply**  
P.O. Box Y  
3301 W. 83rd Street  
DeSoto, KS 66018  
913-585-1191  
800-646-7736 (toll-free)  
[www.caprinesupply.com](http://www.caprinesupply.com)

**Hoegger Supply Company**  
160 Providence Road  
Fayetteville, GA 30215  
800-221-4628 (toll-free)  
[www.hoeggergoatsupply.com](http://www.hoeggergoatsupply.com)

**Sydell**  
46935 SD Hwy. 50  
Burbank, SD 57010-9605  
605-624-4538  
800-842-1369 (toll-free)  
605-624-3233 (FAX)  
[www.sydell.com](http://www.sydell.com)

**Hamby Dairy Supply**  
2402 SW Water Street  
Maysville, MO 64469-9102  
800-306-8937 (toll-free)  
[www.hambydairysource.com](http://www.hambydairysource.com)

**Tarter Farm and Ranch Equipment**  
P.O. Box 10  
Dunnville, KY 42528  
[www.tartergate.com](http://www.tartergate.com)

**NASCO**  
901 Janesville Avenue  
P.O. Box 901  
Fort Atkinson, WI 53538-0901  
800-558-9595 (toll-free)  
[www.enasco.com](http://www.enasco.com)

**Jeffers Livestock Supply**

P.O. Box 100  
Dothan, AL 36302  
800-JEFFERS or 800-533-3377 (toll free)  
334-793-6257  
334-793-5179 FAX  
[www.jefferslivestock.com](http://www.jefferslivestock.com)  
[customerservice@jefferspet.com](mailto:customerservice@jefferspet.com)

**Premier**

800-282-6631 (toll-free)  
[www.premier1supplies.com](http://www.premier1supplies.com)

**Pipestone Veterinary Supply**

P.O. Box 188  
1300 Hwy 75 S.  
Pipestone, MN 56164  
800-658-2523 (toll-free)  
[www.pipevet.com](http://www.pipevet.com)

**Ketcham's Sheep Equipment ("Red Stuff")**

6471 Miller Drive  
Edwardsville, IL 62025  
618-656-5388  
[www.ketchamssheepequipment.com](http://www.ketchamssheepequipment.com)

**Ketchum Manufacturing Inc.**

1245 California Ave.  
Brockville, ON, Canada  
K6V 7N5  
613-342-8455  
613-342-7550 (FAX)  
[ketchum@sympatico.ca](mailto:ketchum@sympatico.ca)  
[www.ketchum.ca](http://www.ketchum.ca)

**Gallagher Animal Management Systems**

Gallagher Power Fence, Inc.  
130 W. 23rd Ave.  
P.O. Box 7506  
North Kansas City, MO 64116  
800-531-5908 (toll-free)  
816-421-2005  
816-421-2009 (FAX)  
[www.gallagherusa.com](http://www.gallagherusa.com)

**Registers Sheep and Goat Supplies**

3398 Gabe Smith Road  
Wade, NC 28395  
1-888-310-9606  
[www.goatsupplies.netfirms.com](http://www.goatsupplies.netfirms.com)

**Sheepman Supply Co.**

8102 Liberty Road  
Frederick, MD 21701  
301-662-4197  
[www.sheepman.com](http://www.sheepman.com)

**Publishers**

Books are available at your bookstore, farm store, or directly from the publishing company.

**Storey Publishing**

MoCA Way  
North Adams, MA 01247  
413-346-2100  
413-346-2199 (FAX)  
[webmaster@storey.com](mailto:webmaster@storey.com)  
consumer orders:  
800-441-5700  
[www.storey.com](http://www.storey.com)

**Barron's Books**

250 Wireless Blvd  
Hauppauge, NY 11788  
800-645-3476  
[www.barronseduc.com](http://www.barronseduc.com)

**Back 40 Books**

Nature's Pace Sanctuary  
Hartshorn, MO 65479  
[CustomerService@Back40Books.com](mailto:CustomerService@Back40Books.com)  
[www.back40books.com](http://www.back40books.com)

**Acres USA**

P.O. Box 91299  
Austin, TX 78709  
800-355-5313  
[www.acresusa.com](http://www.acresusa.com)



# Notes

---

**Small Ruminant Resources**

By Linda Coffey, Jana Reynolds and Margo Hale, NCAT  
Agriculture Specialists

Updated by Linda Coffey, Margo Hale and Hannah Lewis,  
NCAT Agriculture Specialists

© 2010 NCAT

Paul Williams, Editor

Robyn Metzger, Production

This publication is available on the Web at:

[www.attra.ncat.org/attra-pub/ruminantresources.html](http://www.attra.ncat.org/attra-pub/ruminantresources.html)

or

[www.attra.ncat.org/attra-pub/PDF/ruminantresources.pdf](http://www.attra.ncat.org/attra-pub/PDF/ruminantresources.pdf)

RL043

Slot 260

Version 090910



# HOLISTIC MANAGEMENT A WHOLE-FARM DECISION MAKING FRAMEWORK

**FUNDAMENTALS OF SUSTAINABLE AGRICULTURE**

[www.attra.ncat.org](http://www.attra.ncat.org)

ATTRA is the national sustainable agriculture information center funded by the USDA's Rural Business -- Cooperative Service.

**Abstract:** This publication serves as an introduction to holistic management and provides resources for further information. Holistic Management™ is a decision making framework that assists farmers and others in establishing a long-term goal, a detailed financial plan, a biological plan for the landscape and a monitoring program to assess progress toward the goal. Holistic Management helps managers to ask the right questions and guides them in setting priorities. In holistic financial planning, profit is planned at the beginning of the year. This is in stark contrast to conventional financial planning where the net profit is often non-existent or a small amount left over once expenses are accounted for.

By Preston Sullivan  
NCAT Agriculture Specialist – July 2001

Sustainable agriculture seeks in principle to “sustain” economic viability, environmental stewardship, and social responsibility. These three tenets are to be embraced as one functional unit. Decisions concerning a sustainable agriculture should then enhance the environment and the farmer’s economic situation and benefit the regional society. Holistic Management™ gives us a way to move forward on these three tenets. It gives us a way to design agriculture to truly mimic nature’s principles of sustainability. It gives us a way to make decisions that automatically take into account the society, the economics, and the environment before they are made.

## What is Holistic Management?

Holistic Management is a simple decision-making framework that can be learned like any

**Contents**

- What is Holistic Management? ..... 1
- The Holistic Management Process.....2
- Financial Planning .....2
- The Landscape That Sustains Us.....3
- Deciding Which Tools to Use .....5
- Testing Decisions .....5
- Monitoring Our Decisions.....6
- Holistic Management-In Practice .....6
- Training is Available.....8
- References .....9



other skill. People who manage holistically can realize an improved quality of life and generate real wealth, while at the same time improving the land and community around them. They develop the ability to ask the right questions and to confidently proceed toward the future they design for themselves. Holistic Management is for anyone who wants consistent profit from agriculture, a high quality of life, and more time to enjoy it. In short, it’s a way to have fun, make money and conserve our natural resource base, all at the same time.

Holistic Management is a process for sorting out and making sense of all the tools and choices that face us each day. Once a person begins to manage holistically, he or she learns what to say no to, and what to say yes to. Being a *proactive*





process, holistic managers learn how to move beyond crisis management and toward planned prosperity. They are able to manage their finances wisely, have more time for enjoyment, live life according to their values, and gain the confidence of knowing that their decisions are improving the environment and the community they live in – leading to a better world for their grandchildren.

## The Holistic Management Process

As the name “holistic” implies, resources are managed in whole units rather than as parts in isolation from their surroundings. In order to have a clear description of what is being managed, people begin by defining their whole. This definition involves a listing of all the decision-makers involved in management, the resources they have to work with, and the money available. From there, a detailed holistic goal is developed. The holistic goal includes a values-based quality of life statement, a listing of forms of production that will make the quality of life possible, and a description of how the land base needs to be far into the future, in order to sustain the production.

Defining the whole and writing a goal is a powerful exercise. People who have written goals are much more likely to succeed than those who do not. Since the holistic goal is based on the deeper underlying values of the decision-makers, it empowers them to ask better questions, to ask the deeper questions, to ask appropriate questions from which they can make better decisions. Some examples include: “Why am I farming in the first place?” “What is it that I’m trying to accomplish?” “What kind of world do I want for my grandchildren?” Building a farm plan on these questions makes for a powerful plan.

The holistic goal remains the centerpiece of holistic management and is referred to constantly when management decisions are being made. The goal is what drives the decision-making. But there’s more. In order to sustain a farm operation, profit must come from somewhere. Most likely, at least some of the profit will come from on-farm enterprises.

## Financial Planning

Holistic managers use a potent financial planning process that empowers them to make decisions that are simultaneously good for the environment, the local community and the bottom line. The holistic financial plan provides a road map to help people navigate through their financial year, assured that the profit will be there at year’s end.

The financial plan allows managers to select enterprises that do not conflict with their values, and then to plan a profit up front. Once the profit is planned from the expected income, expense dollars are allocated sequentially where they will do the most good.

Holistic financial planning differs from conventional financial planning in several ways. Conventional cash flow budgeting involves estimating income from an enterprise, then allocating expenses for capital investment, variable costs, and fixed costs. Attempts are made to keep costs below anticipated gross income by using past records and other information and adjusting for cost trends. As long as the expenses appear cost effective and the plan predicts no cash shortages the bank won’t cover, all should go well. Still, the results of cash flow planning often include considerable anxiety towards year’s end over the profit margin. In many cases, the expenses nearly equal the planned gross income, producing very little profit (1). Usually there are plenty of excuses to make up for the small margin – weather, markets, and pests. All too often we may take the attitude of, oh well, things will be better next year.

With holistic financial planning the projected income is planned, then the desired profit is allocated at the outset, heavily affecting how the remainder of the budget will be allocated. Planning a hefty profit before any expenses are allocated is a key distinction. After profit is planned, expenses are allocated into three categories: Wealth generating, Inescapable, and Maintenance (W I M for short). Wealth generating expenses produce profit for the operation this year. Inescapable expenses must be paid regardless (taxes, land payments, etc.), while maintenance expenses, though essential to the business, do not produce profit this year.

Overhead and variable categories are not used at all because they don't describe what the expenses within each category do for the enterprise. Once the holistic financial plan is written, it is monitored monthly to stay on track toward the planned profit. Monthly monitoring allows deviations from plan to be caught early and corrected before there is serious financial trouble. The financial planning process helps control three human tendencies that work against financial success: 1) the tendency to allow cost of production to rise to the level of optimistically anticipated income, 2) the tendency to borrow heavily against the optimistically anticipated income, 3) the tendency to do little planning ahead of time on paper. Even when planning is done

using conventional cash flow budgeting, production is the goal, not profit. With holistic financial planning, profit is the goal and production is the means of achieving it. That's why profit is allocated right off the top of anticipated income. Planning a hefty profit up front forces the manager to overcome the three tendencies that lead to low profit margins. From there, meeting necessary expenses after planning our profit requires creativity. How the profit is used at the end of the year is unimportant, but the objective of holistic planning is to make sure there will be a substantial profit at the end of the year. Some of the key distinctions between holistic financial planning and the conventional cash flow model that most farmers use are shown in Table 1.

Table 1. Distinctions between holistic financial planning and cash flow planning.

Holistic	Cash-flow
profit is the goal	production is the goal
profit is planned first	profit is what's left over
expenses put into W I M categories	expenses put in overhead and variable costs
monthly monitoring to stay on track	annual monitoring?

Figure 1 below shows a comparison between a cash-flow budget and a holistic budget for a dairy farm in Ohio (2). Each budget used the same projected income; however, the cash-flow budget uses expense categories which in effect mask any knowledge of where to cut expenses without affecting profit. Notice that no debt service is broken out and a shortfall of \$26,000 is shown.

With the holistic budget, the expenses are put into categories of wealth generating expenses, inescapable expenses, and maintenance expenses. Using these categories, one can easily see where to cut expenses, while preserving our planned profit and still meeting our debt obligations. The excess maintenance expenses of \$26,000 will have to be cut by creative means to preserve our profit and still meet the debt obligation.

There is much more to holistic financial planning than has been introduced here. Some additional aspects include managing debt, testing financial decisions toward a well-defined goal, creating and using a livestock production worksheet to plan cattle buying and selling, and brainstorming new enterprises.

## The Landscape That Sustains Us

Since we all depend directly on the landscape for our very existence (food, clothes, water, etc.), we benefit greatly from gaining a complete understanding of how the landscape functions. The very essence of the term "holistic" is that nature functions only in wholes, not in parts, and that we will understand nature better when we manage it as a whole rather than as separate parts. Holistic Management gives people a way to make decisions that more accurately mirror the way nature functions (in wholes) and thereby ensure that our farming is truly sustainable over time.

To better understand how nature functions, her basic processes need to be considered. Looking closely, four basic processes can be found in all natural systems. First, water falls to earth as rain, filters through the soil and is either taken up by plants or continues downward to become ground water. When water is cycling effectively, floods are infrequent and of lower impact, water is released slowly through underground flow into springs and streams, and erosion is virtually non-

<b>Cash-flow Budget</b>	
Income.....	150,000
Operating Expenses.....	110,000
Administrative Expenses.....	62,000
Capital Expenditures.....	4,000
Cash flow.....	<26,000>
<b>Holistic Budget</b>	
Income.....	150,000
Debt Service.....	36,000
\$ Available for Operations.....	114,000
<i>Less 25% profit.....</i>	<i>28,500</i>
\$ Available for Expenses.....	85,500
Wealth generating expenses.....	9,100
Inescapable expenses.....	3,400
\$ Available for Maintenance.....	73,000
Maintenance expenses.....	99,000
<b>Excess maintenance expenses to be cut.....</b>	<b>26,000</b>

Figure 1. Comparison of budgeting process in holistic & conventional management

existent. If on the other hand, bare soil is exposed and plant density is low, most water runs off the landscape rapidly resulting in soil erosion, much less water entry into the soil, and severe and more frequent flooding. So, an effective water cycle is apparent in nature and essential to a sustainable agriculture.

A second natural process we can observe in nature is the mineral cycle through the biological system. Minerals needed for biological growth are constantly recycled from soil to plant to animal and back to soil again. There is very little waste in the natural mineral cycle. There is no need for fertilizer in nature, as all the fertility is recycled again and again with very little loss. Ultimately, to be sustainable, we need to find ways to utilize the natural mineral cycle while minimizing our off-farm purchase of minerals. Farming practices that inhibit the natural mineral cycle, only reduce the sustainability of our farm.

A third natural process shows us that plant and animal communities strive toward high biodiversity. Not only is diversity high in the numbers of species, but also the genetic diversity within species, and a wide age structure of each population present. Greater diversity produces greater stability within the system. It also assures minimal pest problems. Large expanses of

monoculture represent a simple level of diversity. Monocultures are almost never present in nature. Monocultures require great energy expenditure, either with fossil fuels or animal and human power to maintain. Weed invasion is nature’s way of injecting diversity into monocultural cropland. When biodiversity is increased, the cost of pest control and fertilizer is decreased. Crop rotation is the first step toward increasing biodiversity on the farm. It helps break weed and pest life cycles and provides complementary fertilization to crops in sequence with each other. Advancing from rotation to strip intercrops represents an even higher level of biodiversity. Strip intercrops of corn and soybeans or cotton and alfalfa are two examples. Increasing habitat for more beneficial organisms with more borders, windbreaks, and special plantings for natural enemies of pests represent even higher levels of biodiversity and stability. For more information on biodiversity, request the ATTRA publications entitled *Intercropping Principles and Production Practices* and *Farmscaping to Enhance Biological Control*.

The fourth natural process involves the flow of energy from the sun through the biological system. The sun is the fuel driving the biology of our farm. Energy flows from the sun through the ecosystem from one level to the next. Sunlight is

absorbed by the green plant, enabling it to grow. Plants are eaten by animals that are in turn eaten by predators which are eaten by even higher predators. During each step, energy is being transferred from one level to the next. Energy is transferred below ground through plant roots that eventually die. The dead roots become food for decomposer organisms. The waste and by-products from the primary decomposers are consumed by another set of secondary decomposers. Finally the residue is broken down into plant available nutrients and soil humus. At each step of the decomposition process, energy is either transferred from one organism to another or is lost as heat.

High energy flow is typified by a thick stand of green plants covering the soil for as long a time as possible. Growing mixtures of two or more plant types increases the leaf area available to capture sunlight. The volume of plants (tight spacing) also enhances energy flow. By growing two or more crops per year, we can lengthen the time that plants are in the field collecting solar energy. If soils are left bare, no sunlight is being converted into energy. When energy flow is reduced by periods when the soil is bare or without a crop, the decomposer organisms living in the soil are on a starvation diet.

When we modify any one of these natural processes (water cycle, mineral cycle, biodiversity, and energy flow) we affect the others as well – after all, they function as a whole. When we build our farm enterprises around these natural processes, we have a plan that will sustain our family today and future generations tomorrow. After all, these are nature’s rules. The sooner we live by them rather than fighting them, the sooner we will produce a sustainable farm. When we fight nature’s rules, we only hurt ourselves in the end.

### **Deciding Which Tools to Use**

The word “tools” is used broadly in holistic management. Though we tend to think first of technology in all its many forms when we think of tools (include everything from hand tools to high tech computers), there are several other tools available to us. The additional tools

include: fire, rest (non-disturbance or letting the land lay idle), grazing, animal impact (trampling the land with very high stock density for a short time) and living organisms (naturally occurring plants and animals which can be harnessed to our benefit). Three additional tools we may not consider as tools are money, labor, and creativity. These last three tools cannot be used alone but only in conjunction with other tools.

Each of the above mentioned tools affects the landscape depending on when and how they are used and in what climatic region. For example, in moist regions with frequent rainfall, rest restores biodiversity to natural landscapes. In dryer areas with seasonal rainfall, rest reduces biodiversity. In those drier regions, animal impact is most beneficial in restoring rangeland health (1).

Many of the technology tools we often use can be replaced by living organisms in creative ways. One example comes from a Canadian rancher who solved his gopher problem by erecting hawk perches over his pastures. When the hawks patrolled the area regularly by using the perches, the gophers left in search of safer feeding areas.

### **Testing Decisions**

Decision making (choosing tools and how to use them) is handled in an organized fashion in Holistic Management. Each decision is subjected to several simple testing questions that enable the decision-maker to see the likely effects of that decision on the whole. By quickly running a decision through the testing questions you get some assurance that the decision will be sound environmentally, economically, and socially.

There are seven tests but not all will apply to every decision. If information is lacking to make the decision, the testing will catch it. Testing forces the manager to consider much more than just cost or gut feel. If the decision fails one or more tests, the decision may be modified and run back through the testing guidelines again. After a second testing failure the decision might be abandoned all together. After a person gains experience, the testing questions become internalized. From that point

on, appropriate testing guidelines automatically come to mind when faced with decisions.

One way to look at testing decisions in this manner is to consider testing as the needle on a compass and the holistic goal as the magnetic north the compass is attracted to. All testing is done toward the holistic goal. In fact, the first question a person should ask is: does this decision take me closer to my holistic goal? If the answer is clearly no, then drop the decision. If the answer is yes or maybe, then test the decision further.

### Monitoring Our Decisions

Because nature is so complex that we can only begin to understand it, decisions affecting the landscape are assumed wrong and closely monitored for early warning indicators of need for change. For example, if range burning is used to increase the plant density, one would look at the plant density later to determine if the effort was successful. By assuming the decision is wrong, we humble ourselves to the great complexity in nature, thus forcing us to monitor to keep on track toward our holistic goal. If we assume our decision is right, we might not monitor at all, or if we did, it would be only to record the results. Once this new holistic perspective is internalized and decisions are made accordingly, things begin to change for the better. Profits increase, the environment improves, and rural families prosper.

### Holistic Management—In Practice

#### Example # 1

Oklahoma rancher Walt Davis realized a number of benefits after he started managing holistically.

The following is adapted from an article he published in the *HRM Quarterly*, Spring 1996: p. 3–4. Table 2 shows major changes and observations before and after holistic management.

Ranching is a biological process, not an industrial process (3). The objective is to promote life and turn it into dollars. Prior to managing holistically, Davis was using many chemicals that kill life. Spraying for horn flies also killed the beneficial insects. When he stopped spraying, the number of horn flies went down. When the cattle were moved regularly, the horn fly larvae that hatched from the cow manure were left behind where parasites could feed on the fly larvae. Their horsefly problem also went away because the solitary wasps that feed on horseflies were able to increase their population without the sprays. Working with nature causes many problems to be designed out of the system while at the same time reducing operating costs.

When Walt changed his calf-weaning program, the need for medications for stress induced by the weaning became unnecessary. Up until this time Davis had looked to technology to fix problems. Taking a closer look at the root cause of this problem led to a new way to wean the calves. He simply separated them from the mother cows with an electric fence.

At first the calves bawled for about 45 minutes, then the mothers and calves laid out next to each other along opposite sides of the fence and were happy. The stress was psychological, not from hunger that formerly made the calves sick. Since starting to manage holistically, Walt prevents most problems rather than solving them with purchased inputs after they happen.

Table 2. The Walt Davis ranch before and after holistic management.

#### Before Holistic Management

Cost \$378/cow  
Fall calving  
Spraying for flies  
Rotating cattle  
Terrible cattle performance

#### After Holistic Management

Cost \$83/cow  
Spring calving  
Flies no longer a problem  
Planned grazing  
Stopped fertilizing pasture  
More pasture plant diversity  
Stopped spraying

The financial planning aspects of holistic management have allowed the Davises to remain profitable for over 15 years in a row. Even through the tough years of 1988 with ¼ of normal rainfall, and 1989 with a short grass season and 1990 when 80% of the ranch went under water, the ranch was still profitable. The most progress in the beginning came from a better understanding of the ecosystem processes. This understanding led to long-term success. When the Davises set their holistic goal, they had a clear picture of where they were going and what they wanted. All their decisions were based on pursuit of that holistic goal.

#### Example # 2

The following discussion is adapted from “Building the Soil First—a successful organic farm” published in *Holistic Management Quarterly*, April 1998. p. 4-5.

Dave Washburn and Meg Anderson, organic vegetable farmers of Stillwater, Minnesota, were an urban couple with a dream of becoming organic farmers. Both had careers in Minneapolis when they quit their corporate jobs and bought a 35-acre farm in Stillwater. They quickly ran into financial challenges and could see no way to recoup their initial investment. Two years into their farming operations they took a course in Holistic Management. Holistic Management made sense to them immediately. Through using the decision-making process they could see clearly which tools were really needed, and that most of the tools on their “wish list” were not needed at all. They quickly learned that marketing and pricing were key to their success. Washburn and Anderson find they can meet their labor needs with local college graduates who want to go into farming. They also hire Hmong workers (Asian hill tribe immigrants) and provide them with land to grow gardens for their own use. When they have decisions to make, they sit down and test them towards their holistic goal. It takes about 5 minutes to come to agreement without any arguments (4).

As of 1998 they serve 250 local families that receive weekly seasonal vegetables through their community supported agriculture operation. The

families pay a set amount at the start of the season for this weekly delivery. All the produce is delivered within 24 hours of harvesting, which gives customers the ultimate in freshness.

Another 55 people signed up for a weekly bouquet of flowers from the farm also. The financial planning helped Dave and Meg see the optimum level of production that allows them to control their own prices. They used the financial planning software to play “what-if” games with different levels of production. Seven years into operation they have more business than they can handle.

#### Example # 3

The following is adapted from “Learning Success” by Ann Adams, published in *Holistic Management In Practice*, July 1998. p. 6-7.

Robert and Cheryl Cosner and their three children operate an 800-acre ranch in the south central part of Washington. They first learned about holistic management in 1984. It wasn't until 1989 that they took their first introductory course and wrote their first holistic plan. They raise registered Angus cattle but have recently started running 40 ewes with their 75 head of cattle with plans to venture into art-quality wool. Since managing holistically they are more able to see the options open to them and are more patient in letting those options unfold.

The impetus to investigate Holistic Management coincided with the breakup of a ranching partnership. The dissolution left them operating in crisis mode and without adequate machinery.

This situation required them to use their creativity. Misfortune actually forced them out of conventional thinking mode and slowed down their decision making. By looking at a problem from a number of angles, they eventually got more information or understanding about the larger issues surrounding the problem. “You have to keep being open,” says Robert. “Change comes in small steps unless you have an instant paradigm shift” (5). Two questions they continue to ask themselves are “How can we solve this problem for free?” and, “What is the least expensive way of getting it done?”

Asking the right kind of questions led them to create a holistic financial plan. They needed some after-tax profit and to pay off their operating loan free and clear so they could build their own line of credit. Paying off their loan became the focus of the financial plan. This focus helped them to make more decisions holistically. Though they wanted to get out of the hay-cutting business, they decided to continue to cut hay until the debt was paid off. Within 5 years, it was paid off. They were pleased at how well the financial planning gave them a target to shoot for and a way to judge their progress. When their banker learned of their financial plan he was so impressed that he discussed the possibility of the Cosners teaching holistic financial planning to some of the banker's other customers. After that, the Cosners realized that their concerns about finances drew them more deeply into practicing holistic management. "The financial planning was a tool that helped us get past the crisis and on to the next stage."

## Training is Available

With rare exceptions, most holistic managers take training from a certified educator in a classroom setting. The Savory Center for Holistic Management in Albuquerque, New Mexico (6), certifies a limited number of educators who have undergone specific training in helping others learn to practice holistic management.

Certified educators are located throughout the world and can also provide technical assistance when necessary. These educators are committed to practicing holistic management in their own lives, seek out opportunities for staying current with the latest developments in holistic management, and maintain high standards of ethical conduct in their work. The coursework each educator offers varies somewhat but generally falls into the following headings:

### Holistic Decision Making

In the introductory course one learns how to:

- make sense out of all the choices faced daily,
- move from crisis management to planned prosperity,
- create more time to enjoy life,

- live life according to one's values,
- test decisions to see if they conflict with the desired lifestyle,
- monitor decisions to stay on track toward a desired lifestyle,
- understand the effect of decisions on the landscape.

Students leave the decision making class with their own values-based holistic goal. There is ample opportunity to practice the decision-making skills in class with the instructor's aid. The holistic goal provides a descriptive road map to the future and a guidepost to decision making for the people who are managing the whole.

### Holistic Financial Planning

In financial planning you will learn: the business of agriculture, why some farmers fail to make a profit, how to select enterprises which are profitable, how to plan a profit and produce it rather than striving for production only, how to allocate expense dollars where they do the most good, how to produce a list of potential enterprises in 20 minutes and pick out the most profitable ones which do not conflict with your values. The financial planning class utilizes many of the decision-making skills learned earlier to make financial decisions.

### Holistic Biological, Grazing, and Land Planning

In this class, people learn how to manage landscapes holistically. You develop skills to create a detailed land plan that includes not only the crop and livestock arrangements but also wildlife and recreational needs and the quality of life defined in the holistic goal. You learn how to manage your landscape in tune with nature's principles, which assures sustainability. You get practice in monitoring rangeland, grassland, and cropland for indicators of how well nature's principles are working on your land. The grazing and land plan complement the financial plan to assure economic, social, and environmental sustainability.

### For More Information

Contact the Savory Center for Holistic Management for more information and a referral to a certified educator in your area or a local network

(see reference #6). Or visit their web page at: [www.holisticmanagement.org](http://www.holisticmanagement.org) Holistic management was first developed by Allan Savory who wrote the book *Holistic Resource Management*, published in 1988. Since that time the book has been updated and the title now is simply: *Holistic Management*. The Savory Center for Holistic Management, which Savory founded in 1985, offers training in holistic management through its network of certified educators across the US and several foreign countries. The Savory Center, staffed by 9 dedicated individuals, operates under the non-profit status. Additionally, they supply many useful materials to holistic managers and educators.

### Summary

In summary, the holistic decision-making process incorporates values-based goal setting, the appropriate use of tools, financial planning, land planning, biological planning, and careful monitoring of effects. All these aspects are managed as a whole unit. The benefits are higher quality of life, financial stability, consistent profitability, and the confidence of knowing that your decisions are improving the environment and the community you live in. It provides people with a means to make decisions that more accurately mirror the way nature functions (in wholes), and thereby ensure that our civilization is truly sustainable over time.

### References:

- 1) Savory, Allan with Jody Butterfield. 1999. *Holistic Management – A New Framework for Decision Making*. Island Press. Covelo, CA. 550 p. Available from the Center (ref. # 6).
- 2) Butterfield, Jody. 1994. Struggling to generate wealth. *HRM Quarterly*. Fall. p. 4-5.
- 3) Davis, Walt. 1996. When values run your ranch. *HRM Quarterly*. Spring. p. 3-4.
- 4) Halpin, Sandra. 1998. Building the soil first – a successful small organic farm. *Holistic Management Quarterly*. April. p. 4-5.
- 5) Adams, Ann. 1998. Learning success. *Holistic Management in Practice*. July 1998. p. 6-7.
- 6) Allan Savory Center for Holistic Management  
1010 Tijeras, N.W.  
Albuquerque, NM 87102  
505-842-5252  
800-654-3619

**By Preston Sullivan**  
**NCAT Agriculture Specialist**

**July 2001**

IP154

The ATTRA Project is operated by the National Center for Appropriate Technology under a grant from the Rural Business-Cooperative Service, U.S. Department of Agriculture. These organizations do not recommend or endorse products, companies, or individuals. ATTRA is located in the Ozark Mountains at the University of Arkansas in Fayetteville at P.O. Box 3657, Fayetteville, AR 72702. ATTRA staff members prefer to receive requests for information about sustainable agriculture via the toll-free number 800-346-9140.







# Feedback

1. Does this publication provide the information you were looking for?  
How could it be improved?
2. Do you know a farmer who is implementing techniques discussed in this publication? Can you provide their address and phone number?
3. Do you know of any related research that would add to the information presented here?
4. Do you know a good related website not listed in this publication?
5. Please add any other information, or comments that you wish to share.



NCAT/ATTR  
PO Box 3657  
Fayetteville, AR 72702

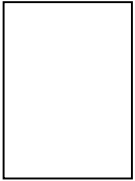

FOLD



*Thank You*  
FOR YOUR VALUABLE FEEDBACK



# Assessment of Plant and Soil Resources



In this section:

- Pastures: Sustainable Management
- Sustainable Soil Management
- Assessing the Pasture Soil Resource
- A Brief Overview of Nutrient Cycling in Pastures
- Nutrient Cycling in Pastures
- Dung Beetle Benefits in the Pasture Ecosystem
- Additional Resources



# Pastures: Sustainable Management

A Publication of ATTRA - National Sustainable Agriculture Information Service • 1-800-346-9140 • [www.attra.ncat.org](http://www.attra.ncat.org)

By Alice Beetz and  
Lee Rinehart  
NCAT Agriculture  
Specialists  
© 2006 NCAT

## Contents

Introduction .....	1
Considerations for Irrigated Pasture Systems in the Western U.S. ....	9
Summary .....	13
References .....	15
Resources .....	16
Appendix: Trees in Pasture Systems .....	18

Well-managed forage systems contribute significantly to the sustainability of a farm/ranch operation. This publication addresses numerous aspects of sustainable pasture integration, grazing rotation strategies, and management options. It covers: grazing systems, pasture fertility, changes in the plant community through grazing, weed control, and pasture maintenance. It also discusses planning and goal-setting, and offers an appendix item on trees in pasture settings.



## Introduction

**M**anagement is the key to healthy, productive pastures. Controlled, rotational, or management-intensive grazing has increased forage production for many producers. Skillfully using livestock to harvest forages leads to improved soil fertility, a diverse, dense, and useful pasture ecology, and an extended grazing season. Fertile soil and productive pastures, in turn, support healthy animals.

Well-managed forage systems contribute to an operation's sustainability in several important ways:

- Lands most susceptible to erosion (or otherwise unsuitable for annual crops) can be maintained as permanent sod.
- Land used for row crops benefits from a year or more in pasture as part of a crop rotation plan. The life

cycles of annual weeds and other crop pests are interrupted during the pasture years of the rotation.

- Soil health improves as the content of organic matter increases under good grazing management.
- Soil structure improves over time as compaction and hardpan is reduced.
- Ruminants (cattle, sheep, deer, goats) thrive in a better balanced agro-ecosystem and produce milk, meat, and fiber from grasses that cannot be digested by humans. Livestock eat excess plant materials while animal wastes contribute nutrients for plant growth.
- Marketing meat, milk, fiber, and other animal products can diversify producer income.





*The sun is the source of energy for the entire planet and much of this energy is captured and stored by plants. Plant fibers that are otherwise unusable by humans are eaten and converted into a new form of stored energy by domestic ruminants, such as cattle, sheep, and goats. Producers can then market this animal meat, milk, and fiber. In a very real sense, annual crop and livestock systems constitute a harvest of the sun and a new source of wealth. And the most efficient system to convert the sun's energy to money is likely to be the most profitable. A dense and diverse forage community offers an excellent opportunity for livestock managers who can harvest and market it.*

In the not-too-distant past, farmers more fully integrated crop and livestock enterprises as a matter of course. Grain produced in field rotation was either sold or fed to livestock, depending on market conditions. Cropland was rotationally seeded to forages, usually for several years. Land not suitable for crop production was grazed. Animals also foraged after-harvest crop residues and the remains of failed crops. These time-honored strategies are not totally absent

from today's agricultural landscape; however, a better integration of crop and livestock enterprises is a necessary step toward the goal of sustainable pasture lands.

## Planning and Goal-Setting

In analyzing your pasture systems, think of yourself as a grass farmer, and the livestock as a means to market the forage. It doesn't matter whether the grass is produced on permanent pasture, on marginal land, or on crop land in the pasture years of a rotation. An excellent goal is to produce

enough good-quality forage to sustain livestock over as much of the year as possible. Then choose the livestock that can best use it.

Of course, different livestock species and classes of livestock have different feed requirements and forage preferences. Most cow-calf operations, for instance, have lower forage nutrition and soil

fertility requirements than do most dairies. Consistent production of high-quality forage under current management makes a dairy or stocker enterprise an option to consider. Otherwise, a different class of cattle, sheep, or other ruminant (either alone or in a multispecies system) may be more suitable to your specific site and management capability.

In setting production goals for any livestock enterprise, consider the economic return per acre rather than production per animal. This is a change from traditional thinking. Compare pounds produced per acre or per dollar invested rather than weaning weights or shipping weights. This type of analysis shows actual profitability more clearly. (See enclosed article by Doug Gunnink for tools to analyze profitability.)

## Renovating Pastures vs. Establishing New Ones

Planting a new pasture offers the opportunity to choose forage species and varieties suited to the livestock type adapted to the soil and climate. Efficiency is further enhanced by matching the season of maximum forage production to the period when livestock can best use it or most need it. Further, planting a diverse mixture of forages with differing maturities provides a high-quality, longer grazing season.

**County or state Extension personnel** are often good sources of information about forage varieties adapted to an area or even to a specific site. The Natural Resources Conservation Service (NRCS) is another good source of information on forage production practices appropriate for particular grazing systems. This agency has been given specific responsibility for helping farmers improve the grazing lands of the United States. Most states have at least one NRCS Grazing Lands Specialist to carry out this mandate. You can find more information about this initiative at [www.glci.org/](http://www.glci.org/).

On the other hand, improving management of an existing pasture is usually preferable to starting a new one. The cost to seed, till, and control weeds for a new pas-

ATTRA has developed several sustainability checksheets for educators and producers to use in evaluating any operation that includes a grazing system. Each is designed to make the producer think about how different parts of the pasture-based enterprise relate to each other. The checksheets were developed by teams of producers and educators and have been tested in several locations. Checksheets currently available include:

- Beef Farm Sustainability Checksheet
- Dairy Farm Sustainability Checksheet
- Small Ruminant Sustainability Checksheet

Call ATTRA to request a printed copy of any of these checksheets, or download them from our Web site at [www.attra.org/livestock.html](http://www.attra.org/livestock.html).

## GOAL OF GOOD GRAZING MANAGEMENT:

The maximum number of animals has plenty of good quality forage to graze throughout as much of the year as possible. The needs of the soil, the plants, and the livestock are balanced to achieve this goal.

## KEY TOOLS OF GRAZING MANAGEMENT:

- Stock density
- Frequency of moves
- Paddock rest

ture is expensive and must be considered. Additionally, a producer must consider the cost to keep livestock off the acreage during the establishment period. The risk of erosion during this transitional period must also be taken into account. In short, it may be more economical, and less disruptive to the soil ecology, to improve an existing pasture's forage by introducing desirable species using no-till seeding methods.

Many pasture problems—such as sparse plant cover, weed invasion, and slow growth—are caused by poor grazing management. If this is the case, establishing a new pasture will not solve the problem. Newman Turner, in *Fertility Pastures and Cover Crops*, observes that good grazing management can transform poor grazing land into healthy, productive pasture. On the other hand, newly reseeded pastures quickly become poor again under bad management. (1) Thus, a careful assessment of management practices is usually the best place to begin to make forage systems more profitable.

## Choosing a Grazing System

Many managers use controlled grazing plans instead of continuous grazing to increase forage utilization and profits. In a system of controlled rotations, pastures are subdivided into paddocks—fenced acreage of any given size. Livestock is moved between paddocks at frequent intervals, giving animals access to a limited pasture area over a short period of time.

The animals do not return to a paddock until the plants have recovered and regrown to the desired height for grazing (usually six to eight inches). As a result, the plants have time to recover, the roots maintain energy reserves, and the livestock always have high quality forage.

Knowledge of forage plants and animal-pasture interaction is necessary to the success of this type of grazing plan—and frequent attention to both is essential. This is why these programs are often referred to as “management-intensive” grazing systems. Controlled, intensive, and rotational grazing are other terms loosely used for this type of grazing management. The subject of grazing management is covered more completely in the ATTRA publication *Rotational Grazing*.

Rotations can vary from once every couple of weeks to every 12 hours. Decisions about when to move livestock are based on the seasonal amount of forage available, the rate of forage growth, and the number and type of animals grazing the paddock. The number and size of paddocks is also considered. Typically, grazing animals are moved quickly through paddocks during periods of rapid plant growth. In the fall, quick rotations keep grasses from going to seed and preserve forage quality. This strategy can delay for several weeks harvesting of forage as hay, allowing for hay to be put up during a dryer time of the season. During other seasons, the grazed area is usually rested long enough for plants to replace carbohydrate reserves and to regrow.

A primary strategy of controlled grazing is to use fencing and livestock movement as tools to manage forage growth and protect it from overgrazing. If managed well, these systems produce more forage and the animals always have access to tender, high-quality vegetation that results from controlled grazing.

**K**nowledge of forage, plants, and animal-pasture interaction is necessary to the success of a controlled grazing plan.

**Profit is the difference** between the cost of production and the price received for a product. Most producers do not control the price they will receive for their livestock (though direct or cooperative marketing arrangements provide a measure of control). Lowering the cost of production is a clear means to increase profit. Costs go down as less feed is purchased and as animal health improves. The key to profitability is to emphasize a decrease in per-unit costs of production over a simple increase in production.

Many grazing managers—or graziers—claim that controlled rotational grazing improves pastures and the profits to be made from them. Forage utilization improves even under high stocking rates when the animals are moved at the right times. Livestock health improves because forage quality and quantity is better. Soil fertility is better because most nutrients cycle through the animals and remain in the paddocks. This can also reduce the need for purchased fertilizer. (See the ATTRA publication: *Nutrient Cycling in Pastures*.) More and better forage means more animal production, which should result in more profit per acre.

A change to controlled grazing involves a modest capital investment. (See ATTRA's *Paddock Design, Fencing, and Water Systems for Controlled Grazing*.) This may include buying and installing electric fence chargers, high-tensile wire fencing, and systems to provide water to each pasture subdivision. A simple system of temporary electric fencing may suffice at the outset for many producers. Water can be delivered initially in above-ground, UV-stabilized pipe. With experience, most graziers will settle on how the permanent systems should be configured. For more information on controlled grazing call ATTRA at 800-346-9140 (toll-free), or visit the ATTRA Web site at [www.attra.ncat.org](http://www.attra.ncat.org).

## Changes in the Plant Community

In a continuous-grazing system where animals are given free choice, they will eliminate the most nutritious or palatable plant species, because they graze them repeatedly. Root reserves of these preferred species are eventually exhausted, and the plants die out. Fescue, bermudagrass, and white clover persist under continuous grazing because their growing points remain, even when the plants are grazed heavily.

In a controlled-grazing system, animals don't have access to all the plants in the pasture at one time. Plants are allowed sufficient time to re-grow and restore their root reserves. Eventually, the plant community

becomes more diverse under this type of grazing system. There is less competition for the same soil minerals, and plants thrive in the specific microclimates where they are best adapted. Producers report that native grass species and many legumes spontaneously appear in their pastures as rotational grazing systems are adopted. In fact, many advise new graziers to “plant only fence posts” in the first three years of intensive rotational grazing, because the plant ecology will change—for the better.

After three years of controlled rotational grazing, analyze the results. Should new forages be added to the pasture to meet specific production or management goals? If a goal is to extend the grazing season to reduce feed costs, new species might be added to existing pastures. Special-use paddocks might also be considered. For example, in southern pastures with cool-season grasses, the summer slump is a time of low forage production and potential health problems, especially from endophyte-infected fescue. Native grasses or plantings of summer annuals can fill this gap in the grazing season. In the Midwest, the grazing season may be extended into the winter by strip-grazing crop residue. Stockpiled fescue or other grasses, if carefully rationed, can support several extra months of winter grazing, even where there is some snow cover. Small grains offer options for fall, winter, and/or spring grazing, depending on regional climate conditions.

## Managing Fertility

Grazed pastures need less fertilizer than those that are hayed. Animals actually use up very few of the nutrients from the plants they eat. Most minerals are returned in animal wastes as part of a natural cycling of nutrients. Phosphorus is excreted primarily in manure, and nitrogen and potassium return in urine and manure. As long as wastes are evenly distributed throughout the grazing area and biological agents such as earthworms, dung beetles, and soil bacteria are active, the system should be relatively stable.

**A**fter three years of controlled rotational grazing, analyze the results.



Good fertility management includes a regular walk through the paddocks to monitor pasture production and to see where specific grasses and legumes thrive. Notice that certain plants tend to thrive under certain soil moisture and fertility conditions. The types and locations of weeds can also indicate how a fertility program is working and help identify special situations such as wet areas. (2)

Conscientious grazing managers record measurements or estimates of available pasture in each section. Using these figures, they budget resources for the future, taking into consideration the amount of rest needed before the next grazing period, as well as the animals' forage needs.

Various plants contribute to soil fertility. Legumes increase the total nitrogen content of the soil (see discussion below). Deeply rooted plants such as alfalfa, warm-season grasses, trees, and some weeds bring up other nutrients from deep in the subsoil. These nutrients remain in the top layers of the soil when the vegetation decays and then become available to other plants nearby. (See *Trees in Pasture Systems* in the **Appendix** for more about the benefits and potential problems related to trees in pastures.)

Periodic soil tests and forage analyses are tools to monitor a pasture's status. Soil test results indicate the levels of mineral nutrients in the soil. Forage analysis is a way to test whether nutrients present in the soil are actually being used by the plants. Many Extension offices offer forage analyses; when requesting this service be sure to specify whether test results will be used to balance a feed ration or for soil fertility decisions. Independent laboratories are available if your local Extension doesn't offer this service. The ATTRA publication *Alternative Soil Testing Laboratories* is available online or upon request.

Soil test results include fertilizer recommendations based on information the farmer provides about field history and planned use. Remember that these recommendations can vary depending on assumptions

by the lab. For example, a recommendation may not be entirely accurate to produce grazing forage if the lab doesn't take into account recycled nutrients by the grazing animals. Lab fertilization recommendations may be over- or underestimated, depending on whether forage is harvested and removed or grazed on site. Use common sense to interpret soil tests, but keep them to monitor changes in soil chemistry and nutrient levels.

A special test to determine micronutrient levels may have to be requested. It is good to check these levels, since they can be critical to soil—and animal—health. When soils show deficiencies in essential micronutrients, supplement either the animals and/or the soil.

Soil organic matter (SOM) is monitored to determine the general health of the soil and its biological residents. You may have to request and pay extra to include SOM in your soil test. On the soil test report, SOM includes any living or partially decomposed materials, as well as humus, the final product of biological activity. When SOM is relatively high, it contributes nitrogen and helps make other mineral nutrients more available to plants. Adding composted animal manure is one way to increase SOM. Likewise, leaving a thin layer of organic residue on the soil surface contributes to SOM, and it shades the soil and feeds the soil organisms. (More about soil organic matter can be found in the section below.)

Some simple methods to assess soil characteristics require just a shovel and a few other widely available pieces of equipment. The ATTRA publication *Assessing the Pasture Soil Resource* describes several tests that can be used periodically for a quick assessment of the soil.

## Soil Amendments

Carefully consider whether purchased amendments are economically justified. If soils are the limiting factor, buying inputs to improve the soil is a wise, long-term investment. In such cases, improvement in soil fertility is key to building a dense,

**A** simple pH adjustment can increase mineral availability in most soils.

lush, and healthy pasture. Such pasture provides good nutrition to grazing animals, and wastes contribute to further build the productivity of the land.

A simple pH adjustment can increase mineral availability in most soils. Legume growth in mixed pastures that tend toward acidity will benefit, and in turn increase available nitrogen and add more organic matter to the soil. Lime is used to raise the pH, but also is an important source of calcium. It is also less expensive than many other purchased fertilizers. The ratio of calcium to magnesium and potassium is important in itself. See the enclosure “Lime, the Forgotten Fertilizer” for more information on this subject.

Composted animal manure might also be an excellent investment because it adds fertility and benefits soil microbes. However, if manure is applied to the same pastures over many years, phosphorus can build up. Excessive phosphorus levels in soils and the threat of phosphorus-saturated soils leaching soluble phosphorus are serious concerns in some parts of the country. See ATTRA’s *Nutrient Cycling in Pastures* for details on the phosphorus cycle and how graziers can prevent phosphorus pollution of surface and ground water.

One situation where fertilizer purchases are often appropriate is in grass dairy operations. Because grass dairies compete with grain-fed systems, producers must provide continuous access to the highest feed value forage available. Likewise, grass-finished meat animals should have plenty of high-quality pasture to gain weight quickly and consistently during the finishing period. Both of these enterprises have potential for good profitability when well managed. Nevertheless, fertilizer inputs are justified only if existing pastures are under full use. The important point is to base decisions on an analysis that compares input costs to the profits or overall benefits that might be generated.

Another excellent resource to understand fertility in grazing systems is *Nutrient Cycling in Forage Systems*, the proceedings of a 1996 conference in Missouri. See **Additional Resources** (under Joost and Roberts) for ordering information. ATTRA also offers *Sustainable Soil Management* and *Assessing the Pasture Soil Resource* for more on pasture fertility and monitoring.

## Organic Matter

Some recent research has focused on the many organisms that make up a healthy soil ecosystem. Plant root systems work together with tiny plants and animals underground in a complex, highly organized system very similar to the one above ground. The soil biological community includes large populations of many species of bacteria, fungi, nematodes, mites, and other microscopic animals. Balances among the populations are maintained by variations in the amount of food available for each part of the system. Elaine Ingham, Ph.D, a soil microbiologist, has named this system the Soil Foodweb.

Ingham offers a service to test soils for the presence of various organisms. (3) However, she says a grazier can monitor pasture soil health just by testing for soil organic matter (SOM) content, which includes carbon contained in living organisms, fresh plant and animal residues, and soil humus. This type of test measures the percentage of soil (by weight) that is SOM. Because organic matter levels are harder to maintain in warmer, more humid climates, what constitutes a “high” or “low” percentage varies in different parts of the country. Local Extension personnel or soil scientists can help define these relative values.

A single test establishes a beginning point, and subsequent tests show whether soil organic matter is increasing. See the box Building Organic Matter for ways to increase soil organic matter, along with practices that decrease it. Avoid practices that adversely affect the number of earthworms in the soil. In fact, counting earth-

### Building Organic Matter

#### These items add organic matter:

- Plant roots
- Plant residues
- Green manures
- Animal manures
- Other organic “wastes”
- Hay and other feed brought in

#### These things destroy organic matter:

- Tillage and bare ground
- Some pesticides
- Compaction
- Continuous cropping

worms in a shovelful of soil is an easy way for farmers to monitor soil health. Increasing worm numbers indicates progress toward the goal of a healthy, biologically active soil.

## Legumes in the Pasture

Legumes increase soil fertility, improve overall feed value of available forage, and extend the grazing season. Bacteria that live in nodules on the legume roots convert nitrogen in the air to a form the plant can use. After the nodules separate from the roots or the plant dies, this nitrogen is available to nearby plants. Even during the growing season, dead leaves fall to the ground and provide extra nitrogen to the pasture system. Compared to grasses, legumes have higher digestibility and higher mineral and protein content.

When introducing legumes into an established grass pasture, first be sure that magnesium and potassium levels are suitable. Then graze the area heavily to set it back. Many producers use a sod-seeder or other no-till seed drill, but some have had luck with frost seeding. This is the practice of broadcast seeding in very early spring into areas where the ground alternately thaws and freezes. Timing must be good to take advantage of these temperature swings. These are conventional practices, and information is widely available about them.

For legumes to prosper in a pasture, the grass must be kept short enough that they are not shaded out. Nitrogen fertilizer favors the grass, and you can inadvertently reduce the percentage of legumes in the pasture mix by adding it. Each species of legume thrives in a particular pH range, but maintaining it between six and seven favors most legumes. Some legumes, such as lespedeza, tolerate more acid conditions.

Many annual clovers produce hard seed and will persist in a pasture if allowed to go to seed periodically. (It is this “hard seed” that accounts for the legumes that seem to appear from nowhere in pastures where management has changed, but no legumes

have been planted.) Annual legumes that do not produce hard seed must be managed to allow some plants to go to seed every year to keep them in the forage mix. Beyond this, providing for the nutritional and light needs of legumes, along with adequate rest after harvest, should ensure their persistence.

If the legume is established and maintained at about a third of the total pasture, the plants won't need additional nitrogen fertilization. Research at Michigan State University shows that different combinations of four cool-season grasses with three clover species produce, on average, 14 percent more forage than the same grasses grown alone and fertilized with 200 pounds per acre of nitrogen. The conclusion is that it doesn't pay to apply nitrogen to pastures with 30 percent or greater mix of legumes. (4) However, it's hard to estimate legume percentage, because the leaf orientation makes it seem a higher percentage of total forage than it actually is. To better estimate overall percentage, sample and weigh plants in an area with a lot of legumes.

Remember, hungry animals introduced to highly leguminous or wet legume pastures may bloat. To prevent this problem, provide hay to animals before they access a legume pasture. Certain products on the market protect livestock from this potentially deadly physiological condition. Since bloating is inherited, if you cull susceptible animals, you may eventually reduce the problem in your herd.

## Managing Weeds

In a controlled-grazing system, livestock can help control tall weeds that re-seed themselves. Because animals have access to a limited area for only a short period, they often become less selective in their grazing. They tend to eat the same weeds—in young, tender growth stages—that they reject as the weeds mature. Many weeds provide good nutrition during this period of palatability. Mowing before weeds flower and produce seed also helps to control them, although the cost is higher.

**W**hen introducing legumes into an established grass pasture, first be sure that magnesium and potassium levels are suitable.



## Conserved Forages vs. Grazing

Providing good-quality forage throughout the year saves considerably on feed costs. Year-round grazing is possible in some parts of the country and is a realistic goal in some regions. Many producers, even those in cold climates, report favorable experiences with attempts to “outwinter” their livestock. Adequate feed and shelter from wind and moisture are critical. Reports indicate that, under favorable conditions, animals seem to prefer being outside where they can forage at will.

A sustainable pasture plan should be based on animals harvesting quality forage for themselves as much as possible. Nevertheless, when spring pastures produce more than livestock can use, machine harvest is one strategy to ensure quality forage later in the grazing season.

Allan Nation, editor of *The Stockman Grass Farmer*, is fond of questioning the economics of owning “heavy metal.” It is expensive to maintain equipment and to harvest forage for hay or silage, so it is sometimes more economical to buy hay or hire a custom baler. However, it can be difficult to find someone to custom harvest and process spring growth at the optimal time.

Another challenge to a spring hay harvest is the weather. A spell of good haying weather, if it comes at all, rarely arrives at the perfect time. One option in wet conditions is to harvest, pack, and seal the excess spring grass in bunkers for fermentation. Livestock, controlled by a single wire of electric fencing, can then have direct access to the silage bunkers.

Some producers advocate baling high-moisture hay and wrapping it so that it will ferment. Baleage, as the product is called, is a high-quality feed when properly harvested and protected from air spoilage. This is one way to harvest on time in wet springs. However, specialized equipment is expensive for one producer to own and operate, and rental may not be available. Several producers in an area with similar needs might recover

Another weed management strategy is to graze different kinds of livestock together. Sheep will complement grass-eating cattle in the pasture by consuming broadleaves, blossoms, and seeds, while goats prefer brushy vegetation high in cellulose. Information about animals’ nutritional requirements and the nutrient content of various forages is available from basic forage and animal science textbooks. For more information on the benefits and challenges of grazing mixed livestock, request the ATTRA publication *Multispecies Grazing*.

A growing number of beneficial insects is becoming commercially available to control thistles and some other perennial weeds. These weed-eating insects are especially adapted to a perennial pasture where habitat is not destroyed or disturbed by annual cultivation. If local sources are unable to help, ATTRA has information about biological management tools and where to get them.

Tall perennial weeds that livestock do not eat can be controlled with the judicious application of a broad-spectrum herbicide, such as Round-Up®. Hand-held sprayers will work, but a wick-type applicator places the chemical on the targeted weed foliage only. Hand-held wicks are available as well as equipment designed to be pulled behind a tractor or four-wheeler. Also on the market are backpack flaming devices that actually burn the weeds and provide a non-toxic option to control difficult weeds. ATTRA publications *Flame Weeding for Agronomic Crops* and *Flame Weeding for Vegetable Crops* provide more detail about this option.

some costs through contractual arrangements among themselves. The amount of plastic used to seal cut forage is a concern for many farmers as well, since it must be disposed of after use. For more information on grass silage or baleage, contact a local Extension office or NRCS personnel.

In summary, conserving forages can help manage fast-growing spring pasture, and hay or silage is useful to carry livestock through some of the year in most parts of the country. However, the goal should be to directly graze as much as possible to avoid the costs to harvest and store forage. Custom harvesting or even buying good hay may be cheaper than maintaining a tractor and implements. (See the enclosed article by Jim Gerrish on the true cost of hay.)

## Considerations for Irrigated Pasture Systems in the Western U.S.

Many regions in the western United States, including intermountain valleys of the Rocky Mountains, the prairies of the northern Great Plains, and certain arid regions of the desert Southwest, experience short grazing seasons due to high elevation, limited moisture, or a combination of both. Livestock producers in these regions find it particularly important to manage forage and pasture in the most efficient way possible. By integrating irrigated pasture with dryland pasture, range, and hay aftermath, the grazing season can be lengthened and livestock provided with high yields of quality forage.

### The Essentials

Conventional wisdom holds that one acre of irrigated pasture in most intermountain valleys provides enough forage for twelve cow-calf pairs for one month. But unproductive irrigated pastures are more the norm, and few producers maintain pasture to its full potential. Productive irrigated pastures are usually the result of successful management of several production factors, including:

- fertility
- irrigation
- species selection
- grazing management

These factors can be managed.

### Fertility

Attention to soil fertility is critically important in irrigated pastures. Pasture establishment is a key time to ensure soil is adequately fertile for the selected forage species to become established and remain productive. During secondary tillage, rock minerals, composted manure, or commercial fertilizers can be incorporated into the soil. In the intermountain regions, it is important to ensure adequate phosphorus and potassium before planting, but nitrogen should be applied early the second spring. Cool, dry springs are difficult on grass seedlings, and nitrogen applied at this time may be appropriated by weeds.

Apply nitrogen only after the grass stand is successfully established. If the stand has a legume component, limit the use of synthetic nitrogen fertilizers. In general, nitrogen fertilization favors grass growth, and phosphorus fertilization favors legumes. Yearly applications of 20 to 50 pounds per acre of phosphorus can significantly increase alfalfa yields and stand persistence in areas deficient in phosphorus. Soil tests are fairly reliable to gauge phosphorus needs, but again, modern soil testing assumes the forage will be harvested and fed on site. Don't underestimate the utility of the mineral fraction of nutrients in the soil, and the natural nutrient cycle that supports pasture ecology.

Whereas most soil nutrients are cycled back to the soil in a grazing system, some nutrients do leave the pasture system in the form of meat and milk. More information on fertility and nutrient cycling can be found in the ATTRA publication *A Brief Overview of Nutrient Cycling in Pastures*.

Irrigation can also have an effect on nutrient cycling. Coarse, porous soils do not retain water as readily as heavier soils, and

**S**ome nutrients do leave the pasture system in the form of meat and milk.

heavy irrigation can leach nutrients into the groundwater. If the pasture has any slope to it, nutrients can leave in runoff. Ditches, dikes, and proper irrigation scheduling can alleviate this problem.

Grass-legume mixes provide good pasture productivity and animal nutrition and aid nutrient cycling and pasture fertility. Pastures with a heavy clover component can produce up to 200 pounds of nitrogen per acre per year, and can supply 6 to 12 percent of the nitrogen needs of companion grass plants during the growing year. Given these prospects, a producer can optimize the use of soluble and organic soil nutrients by relying on plant species diversity and nutrient cycling from manure, urine, and plant senescence to supply a large portion of pasture soil fertility. More detailed information on this subject can be found in the sections **Managing Fertility** and **Organic Matter**.

**N**ever irrigate and graze at the same time.

### **Irrigation**

Efficient water use is crucial for sustainable irrigated pasture management. Irrigated pastures require about 24 inches of water per growing season. What is not supplied by precipitation needs to be made up with efficient irrigation. Grasses and legumes require about 0.20 and 0.25 inches of water per day respectively throughout the growing season. So, frequency of irrigation depends on soil texture and, in turn, on water holding capacity of the soil.

Heavier (clay) soils hold more water, up to 2.5 inches per foot of rooting depth, and coarser (sandy) soils hold less water, around 0.75 inches per foot. Pastures have an effective moisture depletion allowance of about 65 percent, which means plants begin to suffer stress after 65 percent of the soil's water-holding capacity has been depleted. For example, pasture soil with a water holding capacity of 1.5 inches per foot, and a rooting depth of four feet, can hold a total of six inches of water. At a 65 percent depletion allowance, 3.9 inches remains available to the plants. If the plants use 0.25 inches per day, an irrigation event that saturates the soil will last about 15 days.

Understanding the basics of soil-water dynamics helps producers make decisions on when to irrigate, especially in areas where water is scarce or energy costs for pumping are high. The Agrimet system (see **Web Resources**) is an excellent resource for producers making irrigation scheduling decisions. In addition, the Natural Resource Conservation Service (USDA-NRCS) district offices have access to each county's soil information and can assist producers to determine the water holding capacity of soil types on area farms. *The Irrigator's Pocket Guide*, developed by NCAT for the NRCS, is an excellent resource with timely information on irrigation scheduling, system capacity, and general water management. It includes figures, forms, and tables to design and manage water systems more efficiently. The *Pocket Guide* has useful information for most areas. It can be ordered from ATTRA by calling 800-346-9140. Other ATTRA publications on irrigation include: *Soil Moisture Monitoring: Low-Cost Tools and Methods* and *Measuring and Conserving Irrigation Water*.

Always remember to irrigate a pasture immediately after the livestock have been moved, and never irrigate and graze at the same time. Hoof action on wet soil can destroy its structure, resulting in compaction and decreased soil productivity for years to come.

### **Species Selection**

The importance of choosing the right plants to use in an irrigated pasture cannot be overstated. The high cost of irrigation, including initial equipment purchase, energy, and maintenance demand that a producer select the most productive plant species for the region. In some situations, short season problems and low yields can be addressed through proper species selection. Choose long-lived, winter-hardy forage plants adapted to your specific soil type. Plants should be capable of high yields and have the genetic potential to withstand grazing and regrow quickly.

Species diversity is also important, as was discussed in detail earlier. Greater productivity and increased biodiversity are fostered through grass-legume mixes. A grass component in a legume pasture can also minimize health problems associated with bloat. Some non-bloating legume species include cicer milkvetch, sainfoin, and birdsfoot trefoil. For the intermountain West, a mixture of two grasses and one legume provide as many, or more, benefits to pasture productivity as do more diverse pastures in higher rainfall areas.

Choose the right species for the mix, however, because species that mature at different times can result in low quality forage. Creeping foxtail and timothy are both excellent irrigated pasture grasses, but foxtail matures several weeks before timothy. Red clovers and vetches usually do not persist as well as alsike clover, white clover, and alfalfa in the intermountain regions. Some good substitutes for alfalfa in irrigated pastures are sainfoin and birdsfoot trefoil, which, unlike alfalfa, are tolerant of high water tables. A very common seed mix for irrigated pastures in the intermountain West is meadow brome, orchardgrass, and alfalfa.

Warm-season grasses are sometimes a good choice for the Southwest and Great Plains, and can result in substantial livestock gains and milk production when managed intensively. Warm-season annuals such as sorghum and sudangrass are good choices for rotational or strip grazing, and are very good if the pasture is used in a crop rotation. Cool-season grasses such as brome, ryegrasses, timothy, and cereals are often higher in digestibility and crude protein, and are more adapted to intermountain, inland Pacific Northwest, and Great Plains regions.

Check with your local county Extension office or conservation district for recommendations on forage species particular to your area. For general purposes, please refer to the Alberta Forage Manual and the Intermountain Planting Guide cited at the end of this publication. These two guides are

excellent sources of information for anyone growing pastures and forages in the intermountain West or northern Great Plains. A list of forage species for Montana and Wyoming—widely adapted to irrigated pastures in many western states—is enclosed.

### ***Forage Cropping Systems to Extend the Grazing Season***

Many western ranchers grow alfalfa hay to provide high quality feed to late-gestation and calving cows in the winter. Most alfalfa fields remain productive for six to eight years in the intermountain West. As sward density diminishes, the stand is generally terminated and placed into small grains for a year or two. This rotation has its benefits. Tillage and crop differentiation allows the producer to break the pest cycle. And termination of an alfalfa field offers an opportunity to augment ranch forage assets with quality pasture while extending the grazing season as well.

For example, a producer might terminate the alfalfa and plant winter wheat in the fall, and then overseed the field with annual ryegrass in the spring. The wheat can be taken as grain, silage, or hay in the summer, allowing the ryegrass to grow for late summer and fall grazing. The same can be done with spring-planted barley. The result



*Fertility and species selection are important. But the single most important factor to increase production on irrigated fields is a workable grazing management system that meets the nutritional needs of livestock and maintains the pasture sward in the vegetative stage throughout the grazing season.*

of this cropping system is a high quality pasture that can be intensively managed with high stocking rates, thereby resting native pastures that might otherwise be grazed the same time each year.

Other systems that work well to extend the grazing season:

- Stockpiling perennial grass or legume forage for fall grazing.
- Early season grazing of winter wheat and subsequent grain harvest.
- Planting perennial grass pastures for use as winter standing forage, e.g., Altai wildrye, which maintains quality well when dormant and stands up under a snow load.

### Grazing Management

Complementary grazing is a system in which livestock are grazed in annual or perennial seeded pastures in the spring and fall, and are taken to native range in the summer when the native grasses are in their prime. This system uses each pasture when it is at its peak in quality and quantity, and it is commonly used in western states to supplement range and extend the grazing season. Within this context, western producers are familiar with continuous grazing. The size and scope of grazing units, coupled with the use of public grazing allotments, often preclude fencing and other necessary infrastructure to support intensively managed rotational grazing. In addition, most producers who graze irrigated meadows also hay them once or twice during the growing season, and only graze them for hay after-

math. For this reason, irrigated meadows tend not to be managed intensively for grazing, as they are seen to be more valuable for winter feed than for summer grazing. After all, that is what the mountain meadows are for.



Photo courtesy of USDA, NRCS

However, for the producer who wishes to scale back on hay production, the irrigated meadows can be used for grazing during the growing season, and upland meadows that consist of bunch grasses like Altai wildrye can be stockpiled for winter feed. Altai wildrye typically remains a high quality forage well into the dormant season, and large bunch grass type holds up well under a snowload.

Producers who choose to develop a rotational grazing system on their irrigated meadows can realize better animal gains per acre and reduced feed costs associated with feeding the cow herd in the winter. See the ATTRA publication *Rotational Grazing* for a general introduction to this type of grazing system. For most cool-season bunchgrass species, 18 to 27 days rest is adequate for substantial regrowth without allowing the plants to become too mature. A problem that can occur in short-season regions is forage maturing in the last pastures to be grazed before the livestock get to it. To deal adequately with this situation a producer might turn livestock in to the first pasture early, maintain a quick rotation, and then slow it down as the season progresses. A good formula to estimate an initial pasture stocking rate is:

$$\text{number of animals} =$$

$$\frac{\text{Pasture size (ac)} \times \text{pasture yield (lb/ac)}}{0.036 \times \text{avg. animals wt(lbs)} \times \text{grazing season (days)}}$$

For example, assume a producer has a 50-acre irrigated pasture of orchardgrass, meadow brome, and alsike clover. A reasonable expectation of dry matter yield in the intermountain West is 2.5 tons per acre, or 5000 pounds per acre. If the producer wants to graze 800-pound yearlings for 90 days, the calculations to figure the stocking rate on an early turn-out to maximize irrigated pasture use is:

$$\text{number of animals} =$$

$$\frac{50 \text{ acres} \times 5,000 \text{ lb/ac}}{0.036 \times 800 \text{ lbs} \times 90 \text{ days}}$$

Again, a rapid grazing rotation during the early season is important to consider. At higher elevations, spring temperatures can dip to freezing each night, slowing grass



growth. Hitting the pastures too hard too early can impede the system's ability to rebound and deliver good forage production later in the summer. Another approach is to decrease the stocking rate until nights become warmer and forage production begins in earnest. Like any rotational grazing system, controlled grazing in the West requires observation, observation, and more observation. The Chinese proverb holds true here: "The best fertilizer for the land is the footprint of the farmer."

### ***A Word about Dragging and Harrowing Pastures***

Avoid using irrigated pastures to winter feed hay unless you plan to renovate, drag, or harrow in the spring. Feeding grounds are subject to soil compaction because of the large numbers of animals that congregate there over the winter. Harrowing pastures to distribute manure, although not always cost-effective, is often recommended in short-season regions, at least once at the beginning of the growing season. In cold regions with short growing seasons, nutrients cycle in the soil at a much slower rate than in more temperate regions. Manure piles therefore tend to break down slower, and dragging can break them up, increasing surface area and, it is thought, aiding in decomposition.

### **Summary**

Sustainable livestock production in the western U.S., as in all regions, requires ranches and farms to rely more on green growing forages as the primary feed for the operation. Careful attention to fertility, efficient irrigation, and grazing season extension through appropriate forage cropping systems are effective ways to lower production costs, reduce off-farm inputs, and build soil resources. In addition, paying attention to species selection and implementing a well-organized and suitable grazing management system fosters continued resource use in perpetuity, aids in the financial well-being of the operation, and ensures that ranching remains a viable livelihood for the next generation.

## **Sustaining Excellent Pastures**

Maintaining a productive plant community that can profitably feed livestock requires attention to the soil, the plants, and the livestock. Each of these alone contributes to excellent pastures, but even more importantly, each affects the others. Too often, farmers attribute problems in a grazing system to the wrong forage species or inadequate fertility, when poor animal-plant-soil management is the real culprit. Bringing in a new species or adding fertilizer rarely solves problems caused by an inattentive manager. How you manage your grazing livestock, however, makes a big difference in pasture improvement. This improved pasture likewise contributes to better health of those same animals.

If you don't already know your soil, get maps and learn about soil types. Use soil test results to decide what amendments to apply. Is your soil organic matter level high or low for your climate? Is it increasing under your management?

Can you identify the plants in your pastures? Are they perennial or annual? Do you know how best to graze these plants? What are their soil requirements? How tall should they be when you begin to graze and at what height should animals be removed?

How do your animals look and behave? Are they alert with bright eyes and smooth coats? Are they skittish or calm? Can you move them without a lot of stress?

Continually monitor your pastures. Are they lush and dense? Is there evidence of soil erosion? Are there many over-mature plants? Have certain areas been grazed too short? Is there some dead plant residue on the soil surface, but not too much? Is leaf color an even, strong green? Are there plenty of legumes in the species mix (about 30 percent by dry weight)? Does the soil feel soft and springy underfoot? Do you have plenty of feed for your animals throughout the grazing season, or are there times (mid-summer? late fall?) when you need more?

Good grazing management is different for each livestock operation. Stock density, fre-

**C**an you identify the plants in your pastures?

Putting it all together in a grazing system for your specific site is a challenge that may take years of observation and creative problem-solving. There is no one way to do it. Keep learning more about your forages and livestock. Seek ideas from other innovators and test them. Implement those that work. Keep fine-tuning the system. The result will be better pastures that better sustain your livestock and you.

quency of moves, forage residual, and plant resting periods are decisions that you make based on goals and preferences. Watch and record what happens as you change one of these factors. These observations will help you, as time goes by, to become a better grazer. Try to understand what causes changes that you see in the soil, plants, or the animals in your pastures. Each constantly affects the others, and the more you learn about how they interact, the more control you will have over your pasture system.

As an example, according to Jim Gerrish, stock density can be used to affect pasture quality, to cycle nutrients, and to regulate forage intake. One expected result of increasing the stock density is that after the animals leave a paddock, forage height will become more uniform.

Since many of the effects of individual decisions will not yield such obvious results, continually seek out more information about intensive grazing. Excellent books, some periodicals, many workshops, and even local field days can help you learn more. A list of written materials and electronic resources is found in **Resources**.

Consult with another rancher or join a producer group to learn more about grazing. Many such grazer groups provide information and support to improve members' systems. Typically, groups include beginners as well as those with years of experience. Activities range from gathering periodically and walking one another's pastures, to meetings with speakers, and seminars. See ATTRA's *Grazing Networks for Livestock Producers* for further information about these groups and how to start one. State forage specialists (either Extension or NRCS) should help you locate a nearby group, if there is one.

Keep records of grazing activities. Keep notes on how many and what types of animals graze each paddock. Write down when they enter and when they leave. Notes about forage heights at entry and removal, as well as estimates of the amount of forage consumed (pounds per acre or some other consistent measure), help determine overall forage production. Other comments about the soil, the

animals, and the plants can be useful later as you analyze records. For instance, when a particular weed species becomes unpalatable or when clover begins to bloom may be valuable to know.

Financial records further help you understand and improve the overall grazing system. Keep track of how much fertilizer you use, when it was applied, and how much it cost. Are there application costs? What other expenses are there? Veterinarian bills, custom services, herbicides, and mowing or dragging expenses should be included in the record-keeping system. Were animals shipped or brought in? When? And for how much?

Whether you use a shirt-pocket notepad or a computer program, these records are central to understand and improve the efficiency and profitability of a grazing system. However, as the manager, you must take time periodically to analyze records. What have you done and when? How well has it worked? Were there unexpected outcomes? Try to figure out what happened. The best-laid plans will not be perfect—especially at first. Outside factors such as the weather and the markets further complicate situations.

As has often been said, there is never an average year. The most successful managers are constantly on the alert, ready to identify problems as they develop—such as thinning pastures or declining livestock health. Good managers are prepared with a plan for every contingency: years of drought or flood, selling or retaining stock during different parts of the price cycles, and the unexpected loss of labor. For example: When a drought sets in, will destocking or buying feed best serve your goals? Which animals should be culled first, and how can they be marketed most profitably? Are there steps you can take to reduce the negative impacts of the drought? Planning along these lines will be appreciated when the situation is at hand. See further information about drought management by searching on “drought” at the ATTRA Web site, [www.attra.ncat.org](http://www.attra.ncat.org).

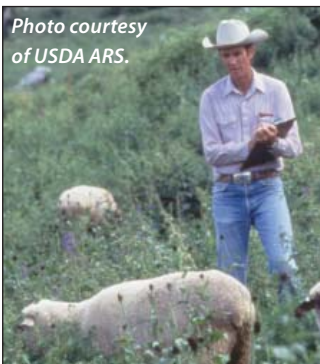

Photo courtesy of USDA ARS.

## Related ATTRA Publications

Rotational Grazing

Grass-Based and Seasonal Dairying

Dairy Farm Sustainability Checksheet

Sustainable Beef Production

Beef Farm Sustainability Checksheet

Sustainable Sheep Production

Goats: Sustainable Production Overview

Small Ruminant Sustainability Checksheet

Matching Livestock and Forage Resources in Controlled Grazing

Meeting the Nutritional Needs of Ruminants on Pasture

Multispecies Grazing

Sustainable Soil Management

Assessing the Pasture Soil Resource

Nutrient Cycling in Pastures

A Brief Overview of Nutrient Cycling in Pastures

Beef Marketing Alternatives

Paddock Design, Fencing, and Water Systems for Controlled Grazing

Grazing Networks for Livestock Producers

## References:

1. Turner, Newman. 1974. *Fertility Pastures and Cover Crops*. 2nd ed. Bargyla and Gylver Rateaver, Pauma Valley, CA. p. 18.
2. Murphy, Bill. 1987. *Greener Pastures On Your Side of the Fence*. Arriba Publishing, Colchester, VT. p. 207-212.
3. Elaine Ingham  
Soil Foodweb, Inc.  
980 Northwest Circle Blvd.  
Corvallis, OR 97330  
541-752-5066  
[www.soilfoodweb.com/](http://www.soilfoodweb.com/)
4. Leep, Rich, and Doo-Hong Min. 2005. Clovers beat commercial N in Michigan studies. *The Forage Leader*. Spring. p. 11.
5. Engle, Cindy. 2002. *Wild Health: How Animals Keep Themselves Well and What We Can Learn From Them*. Houghton Mifflin Company, New York, NY. 276 p.
- Gerrish, Jim. 1999. Strategies for pasture improvement. *Forage Systems Update*. January 1. p. 1-3.
- Gunnink, Doug. 1993. Gross margin analysis helps show the way to grazing profits. *The Stockman Grass Farmer*. April. p. 14-15.
- Holzworth, L., and J. Lacey. 1991. Species Selection, Seeding Techniques, and Management of Irrigated Pastures in Montana and Wyoming. p. 9-12. In: *Irrigated Pastures in Montana and Wyoming*. EB 99. MSU Extension Service, Bozeman, MT.
- Hoveland, Carl S. 2001. Know your forages...clover. *The Stockman Grass Farmer*. January. p. 10-11.
- Joost, Richard. 1997. Pasture soil fertility management. p. 35-46. In: Gerrish, Jim, and Craig Roberts (eds.). 1997. *Missouri Grazing Manual*. University of Missouri, Columbia, MO. 172 p.
- Martyn, Roger. 1994. Lime, the forgotten fertilizer. *The Stockman Grass Farmer*. March. p. 14.
- Mueller, Ray. 1999. Pasture fertilizing practices vary according to goals, needs.
- Sheath, G.W., R.J.M. Hay, and K.H. Giles. 1987. Managing pastures for grazing animals. p. 65-74. In: *Livestock Feeding on Pasture*, New Zealand Society of Animal Production Occasional Publication No. 10. Private Bag, Hamilton, NZ.

## Resources

*The Stockman Grass Farmer* (see Periodicals, below) is an excellent monthly publication that covers alternative forages and innovative management. Many of the articles are written by producers and contain practical tested ideas. (Be warned: evaluate each new practice before committing resources to it.) The commercial and classified ads offer services and supplies that grass farmers need and that may be difficult to find locally. A free sample issue is available to those who call or write to request it.

*Graze* (see Periodicals, below) is another outstanding monthly that includes articles on all aspects of grazing, pasture management, and marketing. In a regular feature, five or more “grazing advisors” answer a question posed by the editor. These advisors, each an active grazing operation manager, represent a variety of livestock types and geographical locations.

Holistic Management® (formerly Holistic Resource Management or HRM) is a decision-making process that was originally developed for livestock management on range. Currently, many farmers and ranchers use this model as a monitoring tool to evaluate options when planning changes to their operations. Contact the Center for Holistic Management for information and referrals to state organizations and regional representatives. The Center also offers a quarterly newsletter.

The Allan Savory Center for Holistic Management  
1010 Tijeras NW  
Albuquerque, NM 87102  
800-654-3619  
[www.holisticmanagement.org/](http://www.holisticmanagement.org/)

Many electronic resources are now available to those with access to a computer. Of particular interest are the interactive listserves used by various livestock ranchers. One that is not species-specific is the graze-l listserve. To subscribe, send a message containing the words “subscribe graze-l” and your e-mail address to [listserv@taranaki.ac.nz](mailto:listserv@taranaki.ac.nz). There are lists specific to many grazing species as well. Beef-l, dairy-l, and sheep-l sometimes address issues related to pasture-raised livestock. It is possible to ask questions and to network with other producers through these and other lists. However, because details on individuals and their specific situations may be lacking, advice received on electronic lists should be carefully evaluated.

Web sites also provide information useful to graziers. Although these sites are constantly changing, and there are more each week, several are listed below. Be sure to check the sites of nearby land-grant universities. Rotational grazing systems are becoming ever more accepted in the mainstream. Extension materials tailored to your state will contain information useful to both the beginner and the experienced grazier.

### Additional Resources

*Books: Irrigated pastures in the western U.S.*

Alberta Forage Manual. 1992. Print Media Branch, Alberta Agriculture, 7000-113 Street, Edmonton, Alberta, Canada. 86 p.

Heitschmidt, Rodney K., and Jerry W. Stuth. 1991. *Grazing Management: An Ecological Perspective*. Timber Press, Portland, OR. 259 p.

Intermountain Planting Guide. USDA-ARS and Utah State University Extension. AG 510. Contact USU Extension for ordering information at 435-797-2251.

*Books: General pasture management*

Ball, Donald M., Carl S. Hoveland, and Gary D. Lacey. 1996. *Southern Forages*. Potash and Phosphate Institute and the Foundation for Agronomic Research, Atlanta, GA. 264 p.

Barnes, Robert F., Darrell A. Miller, and C. Jerry Nelson (eds.). 1995. *Forages: The Science of Grassland Agriculture*. 5th ed. Vols. 1 and 2. Iowa State University Press, Ames, IA. 516 p. and 357 p., respectively.

Bingham, Sam, with Allan Savory. 1990. *Holistic Resource Management Workbook*. Island Press, Covelo, CA. 182 p.

Blaser, Roy E. 1986. *Forage-Animal Management Systems*. Virginia Agricultural Experiment Station Bulletin. Virginia Polytechnic University, Blacksburg, VA. 90 p. [This publication is out of print but is well worth the effort to locate at land-grant university libraries or through Interlibrary loan.]

Chessmore, Roy A. 1979. *Profitable Pasture Management*. The Interstate Printers & Publishers, Inc., Danville, IL. 424 p.

Gerrish, James R., and Craig Roberts. 1999. *1997 Missouri Grazing Manual*. Forage Systems Research Center Agricultural Experiment Station, University of Missouri. 163 p.

- Hodgson, John. 1990. *Grazing Management: Science into Practice*. Longman Handbooks in Agriculture. John Wiley & Sons, New York, NY. 203 p.
- Hodgson, J., and A.W. Illius (eds.). 1996. *The Ecology and Management of Grazing Systems*. CAB International, Wallingford, UK. 466 p.
- Joost, Richard E., and Craig A. Roberts. 1996. *Nutrient Cycling in Forage Systems*. Proceedings of a conference March 7-8, 1996, Columbia, MO. Potash and Phosphate Institute and Foundation for Agronomic Research, Manhattan, KS. 243 p.  
Available for \$15 from:  
Potash and Phosphate Institute  
772 22nd Avenue S.  
Brookings, SD 57006  
605-692-6280
- Langer, R.H.M. 1990. *Pastures: Their Ecology and Management*. Oxford University Press, New York, NY. 499 p.
- Murphy, Bill. 1998. *Greener Pastures on Your Side of the Fence: Better Farming With Voisin Grazing Management (4th ed.)*. Arriba Publishing, Colchester, VT. 379 p.  
Available for \$30 from:  
Arriba Publishing  
213 Middle Rd.  
Colchester, VT 05446
- Nation, Allan. 1993. *Grass Farmers*. Green Park Press, Jackson, MS. 192 p.
- Nation, Allan. 1992. *Pa\$ture Profit\$ with \$tocker Cattle*. Green Park Press, Jackson, MS. 190 p.
- Nation, Allan. 1995. *Quality Pasture: How to Create It, Manage It, and Profit from It*. Green Park Press, Jackson, MS. 285 p.
- Ness, Julia Ahlers (ed.). 1998. *The Monitoring Tool Box*. The Land Stewardship Project, White Bear Lake, MN. 45 p.  
Available for \$45 from:  
Land Stewardship Project  
2200 Fourth St.  
White Bear Lake, MN 55110  
651-653-0618  
[www.landstewardshipproject.org](http://www.landstewardshipproject.org)
- Nicol, A.M. (ed.). 1987. *Livestock Feeding on Pasture*. Occasional Publication No. 10. New Zealand Society of Animal Production. Private Bag, Hamilton, New Zealand. 145 p.
- Savory, Allan, and Jody Butterfield. 1999. *Holistic Management: A New Framework for Decision Making*. Island Press, Covelo, CA. 616 p.
- Turner, Newman. 1974. *Fertility Pastures and Cover Crops*. Bargyla and Bylver Rateaver, Pauma Valley, CA. 202 p.
- Voisin, Andre. 1988. *Grass Productivity (reprint)*. Island Press, Covelo, CA. 353 p.
- Wilkinson, J.M. 1984. *Milk and Meat From Grass*. Granada, New York, NY. 149 p.

### *Periodicals*

The Forage Leader  
American Forage and Grassland Council  
P.O. Box 891  
Georgetown, TX 78627  
800-944-2342

Graze  
P.O. Box 48  
Belleville, WI 53508  
[www.grazeonline.com](http://www.grazeonline.com)  
\$30 for 1 year subscription (10 issues)

Hay and Forage Grower  
Webb Division  
Intertec Publishing Corp.  
9800 Metcalf  
Overland Park, KS 66212-2215

The Stockman Grass Farmer  
282 Commerce Park Drive  
Ridgeland, MS 39157  
800-748-9808 (toll-free)  
[www.stockmangrassfarmer.com](http://www.stockmangrassfarmer.com)

*Electronic Resources: General pasture management, southern and eastern pastures*  
[Note that these addresses change often.]

The Great Lakes Grazing Network  
[www.glgm.org/](http://www.glgm.org/)

Cornell Forage-Livestock System  
[www.css.cornell.edu/forage/forage.html](http://www.css.cornell.edu/forage/forage.html)

Penn State College of Agricultural Sciences  
Publications  
<http://pubs.cas.psu.edu/Subject.html>

American Farmland Trust's Grassfarmer Site  
<http://grassfarmer.com>

University of Wisconsin Forage and Extension Links  
[www.uwex.edu/ces/forage/links.htm](http://www.uwex.edu/ces/forage/links.htm)

Forage Systems Research Center  
<http://pubs.cas.psu.edu/Subject.html>[laes.missouri.edu/fsrc](http://laes.missouri.edu/fsrc)

Tom Trantham's Twelve Aprils Dairying  
[www.griffin.uga.edu/sare/twelve/trantham.html](http://www.griffin.uga.edu/sare/twelve/trantham.html)

Modern Forage Seeds  
[www.modernforage.com/classroom.htm](http://www.modernforage.com/classroom.htm)

Sustainable Farming Connection's Grazing Page  
[www.ibiblio.org/farming-connection/grazing/home.htm](http://www.ibiblio.org/farming-connection/grazing/home.htm)

### *Electronic Resources: Western irrigated pastures*

Holzworth, L., and J. Lacey. 1991. Species Selection, Seeding Techniques, and Management of Irrigated Pastures in Montana and Wyoming. Montana State University Extension. EB 99. 17 p.  
<http://animalrangeextension.montana.edu/articles/Forage/grasses/mteb99.pdf>

Small Pasture Management Guide for Utah. USDA/NRCS, Utah State University Extension, and Utah State Conservation Districts. 11 p. <http://extension.usu.edu/files/agpubs/Pasture.pdf>

Interagency Forage and Conservation Planting Guide for Utah. Edited by Howard Horton, USDA/ARS. Utah State University Extension. AG-433. 79 p.  
<http://extension.usu.edu/files/agpubs/ag433.pdf>

Lundin, F. 1996. Coastal Pastures in Oregon and Washington. Oregon State University. EM 8645. 8 p.  
<http://eesc.orst.edu/agcomwebfile/edmat/EM8645.pdf>

Frost, B. and M. Schneider. 1994. Establishing irrigated pasture at 4000- to 6000-foot elevations in Arizona. Arizona Cooperative Extension. #194028. 6 p.  
<http://cals.arizona.edu/pubs/natresources/az9428.pdf>

Redmon, L. 2003. Forage Establishment, Management, and Utilization Fundamentals. Texas Cooperative Extension. SCS-2003-07. 8 p.  
<http://forages.tamu.edu/PDF/scs-2003-07.pdf>

Water Quality and Irrigation Management. Department of Land Resources and Environmental Sciences. Montana State University.  
<http://waterquality.montana.edu>

The Great Plains Cooperative Agricultural Weather Network. U.S. Dept. of the Interior.  
[www.usbr.gov/gp/agrimet/index.cfm](http://www.usbr.gov/gp/agrimet/index.cfm)

AgriMet is a network of more than 90 automated weather stations that collect and telemeter site-specific weather data. This information is translated into crop-specific water use information. The primary emphasis is on irrigation management and applying the right amount of water at the optimal time.

### *Electronic Listservers*

#### *Graze-L*

To subscribe send an e-mail to [majordomo@taranaki.ac.nz](mailto:majordomo@taranaki.ac.nz) or [listserv@taranaki.ac.nz](mailto:listserv@taranaki.ac.nz). In the body of the e-mail, type "subscribe graze-l"

#### *The Grazer's Edge*

To subscribe send an e-mail to [grazersedge-subscribe@onelist.com](mailto:grazersedge-subscribe@onelist.com). In the body of the e-mail, type "subscribe grazersedge."

## APPENDIX: Trees in Pasture Systems

Trees in a pasture provide several services, but they can also be challenging. They affect soil fertility, hold surface soil in place, give livestock relief from the sun and the wind, and change water relations. They can supplement other feed sources, increase wildlife habitat, and become an additional source of income.

Trees gather nutrients from a large area to sustain both above- and below-ground parts and deposit those nutrients on the soil surface. Tree roots go deep into the soil and spread underground at least as far as the edge of the leaf canopy. When the leaves fall, the microorganisms in the top layer of the soil convert them into nutrient forms to be used again by the tree and by nearby forage plants. Tree roots continually grow and die. The dead roots are broken down in the soil and contribute directly to organic matter, increasing water retention and improving soil structure.

Shade trees in pastures can be a benefit, but they can also create problems. It is cooler under the trees, and livestock tend to congregate there. These areas become nutrient sinks. That is, nutrients gathered during grazing are later deposited under the trees as waste. This nutrient transfer from open pasture to under the trees reduces pasture productivity. These and other areas of high animal concentration or repeated use (like around water and minerals) also tend to accumulate parasites, which then reinfest the livestock. Livestock concentrating around a tree can also lead to compaction around the root zone and result in the loss of a tree.

Although no studies have shown that providing shade for livestock results in a production benefit, most producers like to make it available for the comfort of the animals. The “shademobile” is an innovative idea, promoted by Joel Salatin, designed to use shade to control where nutrients will be redeposited. It is an open-sided structure with a canvas or shade cloth cover that is towed by a tractor from paddock to paddock. Moving the shade around constantly changes the loafing area and controls where manure is deposited, while preventing parasite build-up.

Windbreaks in or around pastures should be planned to provide shelter from cold or hot, drying winds and to protect newborns from harsh weather. Windbreaks that include several species of shrubs and trees become valuable wildlife habitat. The resulting wildlife create an opportunity for spin-off enterprises such as lease hunting or bird-watching.

Plants and animals make their homes in all levels of tree canopies and understories. The birds help control insect pests, and some eat weed seeds. Larger predatory birds help control small-mammal populations. Birds roosting in trees even add their phosphorus-rich droppings to the nutrient cycle. This biological diversity increases the stability of the ecosystem and mediates against the disasters that monocultures are subject to.

To avoid the problems associated with shade, some farmers fence the tree area so that animals can't use the area at all. Or you can remove trees' lower limbs, so the shaded area moves across the pasture as the sun crosses the sky, and animals must move to follow it. The result is a more uniform pattern of waste distribution.

Trees can reduce erosion on hilly land. If planted in strips along the contour, they create a natural terracing effect. Over time, organic matter will accumulate along the line of trees, and the slope will become more productive and stable. As an added advantage in dry seasons, more water is stored underground in these terraced systems.

On the other hand, when they are planted in wet areas, trees collect water in their extensive root systems and “pump” it out through the leaves by transpiration. Poplars and eucalyptus have been used to reduce surface salinity in areas where water lies too close to the surface.

Agroforestry is a term applied to farm systems that intentionally integrate trees as an additional enterprise or for their environmental services. Nut trees or high-value timber are especially popular in pastures.



Although trees require additional care and management, they can provide a long-term source of additional income. With good management—particularly attention to marketing—both nuts and thinnings provide sources of income before the final timber harvest.

While the trees are still young, row crops may be grown between them. When the canopy begins to close, and light is inadequate for row crops, forage crops can be grown for hay. When the trees are large enough that they can't be damaged by livestock, the area can be directly grazed. This reduces mowing costs while contributing to fertility for tree and forage growth.

Small trees need protection from livestock and deer. Deer, like domestic livestock, browse on young tree growth and will eat any parts that they can reach, threatening the survival of young trees. An alleyway with electric fencing on either side of seedling rows will provide protection. You can buy plastic tubes that fit around each sapling and guard the young tree from grazing and wind. New tube designs with ventilating holes to allow for air circulation prevent the increased pest and disease problems encountered with earlier designs.

Information on all types of agroforestry practices is available in the ATTRA publication *Agroforestry Overview*.

Many trees and shrubs produce seeds, leaves, or nuts that supplement existing forages and provide valuable feed during certain times of the year. Because trees and shrubs are perennials with long life expectancies, few annual costs are associated with their continued productivity. Fodder trees—such as locusts, willows, some poplars, leucaena, and tagaste—have potential for either seasonal or year-round browsing. In some

cases, seasonal cutting back to the trunk will produce tender shoots that are more palatable and easily accessible to the animals that browse them directly, but if animals have continuous access, they may exhaust root reserves and kill the trees. In some regions, tree fodder is considered an emergency feed for unusually dry seasons.

Like forage legumes, leguminous trees such as black locust and honey locust fix nitrogen. Rhizobial bacteria live closely with their roots, converting nitrogen from the air into a form that the trees can use. The nitrogen

is used by the tree, but when the leaves die, they add to the total nitrogen in the pasture system.

Traditional beliefs hold that animals will select a diet according to their needs, if they have access to a wide variety of plants, including shrubs and trees in the pasture or hedgerow. When appropriate species are available, livestock may select them to self-medicate for their health problems. Cindy Engel in *Wild Health: How Animals Keep Themselves Well and What We Can Learn From Them* (5) explores this idea in some detail.

**Pastures: Sustainable Management**

By Alice Beetz and Lee Rinehart  
NCAT Agriculture Specialists  
©2006 NCAT

Paul Driscoll, Editor  
Amy Smith, Production

This publication is available on the Web at:  
[www.attra.ncat.org/attra-pub/sustpast.html](http://www.attra.ncat.org/attra-pub/sustpast.html)  
or  
[www.attra.ncat.org/attra-pub/PDF/sustpast.pdf](http://www.attra.ncat.org/attra-pub/PDF/sustpast.pdf)

IP 284  
Slot 51  
Version 032306



# SUSTAINABLE SOIL MANAGEMENT

SOIL SYSTEMS GUIDE

***Abstract:** This publication covers basic soil properties and management steps toward building and maintaining healthy soils. Part I deals with basic soil principles and provides an understanding of living soils and how they work. In this section you will find answers to why soil organisms and organic matter are important. Part II covers management steps to build soil quality on your farm. The last section looks at farmers who have successfully built up their soil. The publication concludes with a large resource section of other available information.*

**By Preston Sullivan**  
**NCAT Agriculture Specialist**  
**May 2004**  
©2004 NCAT

## Table of Contents

Part I. Characteristics of Sustainable Soils .....	2
Introduction .....	2
The Living Soil: Texture and Structure .....	2
The Living Soil: The Importance of Soil Organisms .....	3
Organic Matter, Humus, and the Soil Foodweb .....	7
Soil Tillth and Organic Matter .....	8
Tillage, Organic Matter, and Plant Productivity .....	10
Fertilizer Amendments and Biologically Active Soils .....	13
Conventional Fertilizers .....	14
Top\$oil - Your Farm's Capital .....	15
Summary of Part I.....	18
Summary of Sustainable Soil Management Principles .....	19
Part II. Management Steps to Improve Soil Quality .....	20
Part III. Examples of Successful Soil Builders (Farmer Profiles) .....	25
References .....	27
Additional Resources .....	28

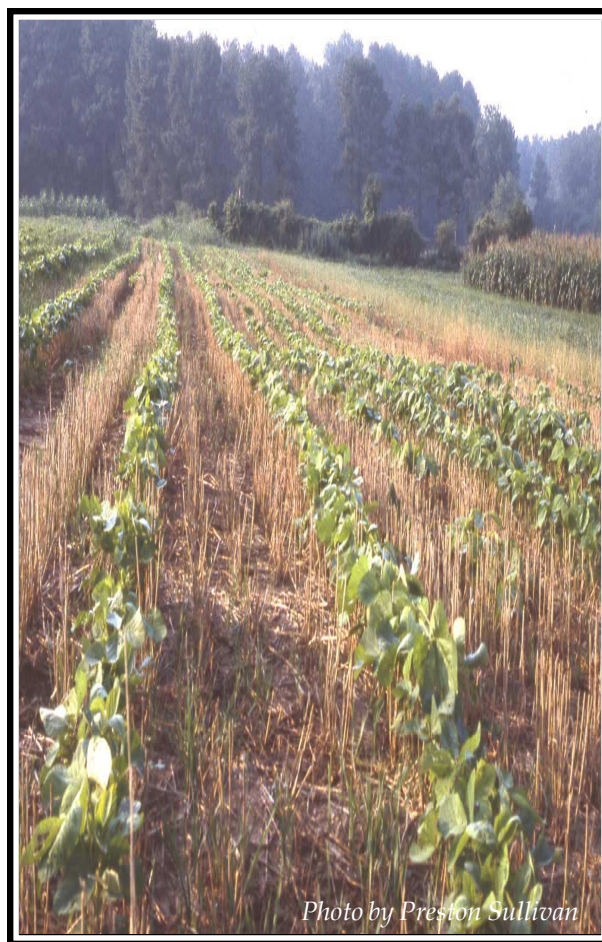

*Photo by Preston Sullivan*  
Soybeans no-till planted into wheat stubble.

ATTRA is the national sustainable agriculture information service operated by the National Center for Appropriate Technology, through a grant from the Rural Business-Cooperative Service, U.S. Department of Agriculture. These organizations do not recommend or endorse products, companies, or individuals. NCAT has offices in Fayetteville, Arkansas (P.O. Box 3657, Fayetteville, AR 72702), Butte, Montana, and Davis, California.



## Introduction

What are some features of good soil? Any farmer will tell you that a good soil:

- feels soft and crumbles easily
- drains well and warms up quickly in the spring
- does not crust after planting
- soaks up heavy rains with little runoff
- stores moisture for drought periods
- has few clods and no hardpan
- resists erosion and nutrient loss
- supports high populations of soil organisms
- has a rich, earthy smell
- does not require increasing inputs for high yields
- produces healthy, high-quality crops (1)

All these criteria indicate a soil that functions effectively today and will continue to produce crops long into the future. These characteristics can be created through management practices that optimize the processes found in native soils.

How does soil in its native condition function? How do forests and native grasslands produce plants and animals in the complete absence of fertilizer and tillage? Understanding the principles by which native soils function can help farmers develop and maintain productive and profitable soil both now and for future generations. The soil, the environment, and farm condition benefit when the soil's natural productivity is managed in a sustainable way. Reliance on purchased inputs declines year by year, while land value and income potential increase. Some of the things we spend money on can be done by the natural process itself for little or nothing. Good soil management produces crops and animals that are healthier, less susceptible to disease, and more productive. To understand this better, let's start with the basics.

Sustainable: capable of being maintained at length without interruption, weakening, or losing in power or quality.

## The Living Soil: Texture and Structure

Soils are made up of four basic components: minerals, air, water, and organic matter. In most soils, minerals represent around 45% of the total volume, water and air about 25% each, and organic matter from 2% to 5%. The mineral portion consists of three distinct particle sizes classified as sand, silt, or clay. Sand is the largest particle that can be considered soil.

Sand is largely the mineral quartz, though other minerals are also present. Quartz contains no plant nutrients, and sand cannot hold nutrients—they leach out easily with rainfall. Silt particles are much smaller than sand, but like sand, silt is mostly quartz. The smallest of all the soil particles is clay. Clays are quite different from sand or silt, and most types of clay contain appreciable amounts of plant nutrients. Clay has a large surface area resulting from the plate-like shape of the individual particles. Sandy soils are less productive than silts, while soils containing clay are the most productive and use fertilizers most effectively.

*Soil texture* refers to the relative proportions of sand, silt, and clay. A loam soil contains these three types of soil particles in roughly equal proportions. A sandy loam is a mixture containing a larger amount of sand and a smaller amount of clay, while a clay loam contains a larger amount of clay and a smaller amount of sand. These and other texture designations are listed in [Table 1](#).

Another soil characteristic—soil structure—is distinct from soil texture. *Structure* refers to the clumping together or “aggregation” of sand, silt, and clay particles into larger secondary clusters.

**Table 1. Soil texture designations ranging from coarse to fine.**

Texture Designation	
	Coarse-textured
	Sand
	Loamy sand
	Sandy loam
	Fine sandy loam
	Loam
	Silty loam
	Silt
	Silty clay loam
	Clay loam
Fine-textured	Clay

If you grab a handful of soil, good structure is apparent when the soil crumbles easily in your hand. This is an indication that the sand, silt, and clay particles are aggregated into granules or crumbs.

Both texture and structure determine pore space for air and water circulation, erosion resistance, looseness, ease of tillage, and root penetration. While texture is related to the minerals in the soil and does not change with agricultural activities, structure can be improved or destroyed readily by choice and timing of farm practices.

## The Living Soil: The Importance of Soil Organisms

An acre of living topsoil contains approximately 900 pounds of earthworms, 2,400 pounds of fungi, 1,500 pounds of bacteria, 133 pounds of protozoa, 890 pounds of arthropods and algae, and even small mammals in some cases (2). Therefore, the soil can be viewed as a living community rather than an inert body. Soil organic matter also contains dead organisms, plant matter, and other organic materials in various phases of decomposition. Humus, the dark-colored organic material in the final stages of decomposition, is relatively stable. Both organic matter and humus serve as reservoirs of plant nutrients; they also help to build soil structure and provide other benefits.

The type of healthy living soil required to support humans now and far into the future will

be balanced in nutrients and high in humus, with a broad diversity of soil organisms. It will produce healthy plants with minimal weed, disease, and insect pressure. To accomplish this, we need to work *with* the natural processes and optimize their functions to sustain our farms.

Considering the natural landscape, you might wonder how native prairies and forests function in the absence of tillage and fertilizers. These soils are tilled by soil organisms, not by machinery. They are fertilized too, but the fertility is used again and again and never leaves the site. Native soils are covered with a layer of plant litter and/or growing plants throughout the year. Beneath the surface litter, a rich complexity of soil organisms decompose plant residue and dead roots, then release their stored nutrients slowly over time. In fact, topsoil is the most biologically diverse part of the earth (3). Soil-dwelling organisms release bound-up minerals, converting them into plant-available forms that are then taken up by the plants growing on the site. The organisms recycle nutrients again and again with the death and decay of each new generation of plants.

There are many different types of creatures that live on or in the topsoil. Each has a role to play. These organisms will work for the farmer's benefit if we simply manage for their survival. Consequently, we may refer to them as soil livestock. While a great variety of organisms contribute to soil fertility, earthworms, arthropods, and the various microorganisms merit particular attention.

### Earthworms

Earthworm burrows enhance water infiltration and soil aeration. Fields that are "tilled" by earthworm tunneling can absorb water at a rate 4 to 10 times that of fields lacking worm tunnels (4). This reduces water runoff, recharges groundwater, and helps store more soil water for dry spells. Vertical earthworm burrows pipe air deeper into the soil, stimulating microbial nutrient cycling at those deeper levels. When earthworms are present in high numbers, the tillage provided by their burrows can replace some expensive tillage work done by machinery.



Figure 1. The soil is teeming with organisms that cycle nutrients from soil to plant and back again.

Worms eat dead plant material left on top of the soil and redistribute the organic matter and nutrients throughout the topsoil layer. Nutrient-rich organic compounds line their tunnels, which may remain in place for years if not disturbed. During droughts these tunnels allow for deep plant root penetration into subsoil regions of higher moisture content. In addition to organic matter, worms also consume soil and soil microbes. The soil clusters they expel from their digestive tracts are known as *worm casts* or *castings*. These range from the size of a mustard seed to that of a sorghum seed, depending on the size of the worm.

The soluble nutrient content of worm casts is considerably higher than that of the original soil (see Table 2). A good population of earthworms can process 20,000 pounds of topsoil per year – with turnover rates as high as 200 tons per acre having been reported in some exceptional cases (5). Earthworms also secrete a plant growth stimulant. Reported increases in plant growth following earthworm activity may be partially attributed to this substance, not just to improved soil quality.

**Table 2. Selected nutrient analyses of worm casts compared to those of the surrounding soil.**

Nutrient	Worm casts	Soil
	Lbs/ac	Lbs/ac
Carbon	171,000	78,500
Nitrogen	10,720	7,000
Phosphorus	280	40
Potassium	900	140

From Graff (6). Soil had 4% organic matter.

Earthworms thrive where there is no tillage. Generally, the less tillage the better, and the shallower the tillage the better. Worm numbers can be reduced by as much as 90% by deep and frequent tillage (7). Tillage reduces earthworm populations by drying the soil, burying the plant residue they feed on, and making the soil more likely to freeze. Tillage also destroys vertical worm burrows and can kill and cut up the worms themselves. Worms are dormant in the hot part of the summer and in the cold of winter. Young worms emerge in spring and fall – they are most active just when farmers are likely to be tilling the soil. Table 3 shows the effect of tillage and cropping practices on earthworm numbers.

**Table 3. Effect of crop management on earthworm populations.**

Crop	Management	Worms/foot <sup>2</sup>
Corn	Plow	1
Corn	No-till	2
Soybean	Plow	6
Soybean	No-till	14
Bluegrass/ clover	--	39
Dairy pasture	--	33

From Kladiwko (8).

As a rule, earthworm numbers can be increased by reducing or eliminating tillage (especially fall tillage), not using a moldboard plow, reducing residue particle size (using a straw chopper on the combine), adding animal manure, and growing green manure crops. It is beneficial to leave as much surface residue as possible year-round.

Cropping systems that typically have the most earthworms are (in descending order) perennial cool-season grass grazed rotationally, warm-season perennial grass grazed rotationally, and annual croplands using no-till. Ridge-till and strip tillage will generally have more earthworms than clean tillage involving plowing and disking. Cool season grass rotationally grazed is highest because it provides an undisturbed (no-tillage) environment plus abundant organic matter from the grass roots and fallen grass litter. Generally speaking, worms want their food on top, and they want to be left alone.

Earthworms prefer a near-neutral soil pH, moist soil conditions, and plenty of plant residue on the soil surface. They are sensitive to certain pesticides and some incorporated fertilizers. Carbamate insecticides, including Furadan, Sevin, and Temik, are harmful to earthworms, notes worm biologist Clive Edwards of Ohio State University (4). Some insecticides in the organophosphate family are mildly toxic to earthworms, while synthetic pyrethroids are harmless to them (4). Most herbicides have little effect on worms except for the triazines, such as Atrazine, which are moderately toxic. Also, anhydrous ammonia kills earthworms in the injection zone because it dries the soil and temporarily increases the pH there. High rates of ammonium-based fertilizers are also harmful.

For more information on managing earthworms, order *The Farmer's Earthworm Handbook: Managing Your Underground Money-makers*, by David Ernst. Ernst's book contains details on what earthworms need to live, how to increase worm numbers, the effects of tillage, manure, and livestock management on earthworms, how 193 chemicals affect earthworms, and more. See the **Additional Resources** section of this publication for ordering information. Also visit the earthworm Web sites listed in that section.

As a rule, earthworm numbers can be increased by reducing or eliminating tillage.

## Arthropods

In addition to earthworms, there are many other species of soil organisms that can be seen by the naked eye. Among them are sowbugs,

millipedes, centipedes, slugs, snails, and springtails. These are the primary decomposers. Their role is to eat and shred the large particles of plant and animal residues. Some bury residue, bringing it into contact with other soil organisms that further decompose it. Some members of this group prey on smaller soil organisms. The springtails are small insects that eat mostly fungi. Their waste is rich in plant nutrients released after other fungi and bacteria decompose it. Also of interest are dung beetles, which play a valuable role in recycling manure and reducing livestock intestinal parasites and flies.

## Bacteria

Bacteria are the most numerous type of soil organism: every gram of soil contains at least a million of these tiny one-celled organisms. There are many different species of bacteria, each with its own role in the soil environment. One of the major benefits bacteria provide for plants is in making nutrients available to them. Some species release nitrogen, sulfur, phosphorus, and trace elements from organic matter. Others break down soil minerals, releasing potassium, phosphorus, magnesium, calcium, and iron. Still other species make and release plant growth hormones, which stimulate root growth.

Several species of bacteria transform nitrogen from a gas in the air to forms available for plant use, and from these forms back to a gas again. A few species of bacteria fix nitrogen in the roots of legumes, while others fix nitrogen independently of plant association. Bacteria are responsible for converting nitrogen from ammonium to nitrate and back again, depending on certain soil conditions. Other benefits to plants provided by various species of bacteria include increasing the solubility of nutrients, improving soil structure, fighting root diseases, and detoxifying soil.

## Fungi

Fungi come in many different species, sizes, and shapes in soil. Some species appear as thread-like colonies, while others are one-celled yeasts. Slime molds and mushrooms are also fungi. Many fungi aid plants by breaking down organic matter or by releasing nutrients from soil

minerals. Fungi are generally quick to colonize larger pieces of organic matter and begin the decomposition process. Some fungi produce plant hormones, while others produce antibiotics including penicillin. There are even species of fungi that trap harmful plant-parasitic nematodes.

The mycorrhizae (my-cor-ry'-zee) are fungi that live either on or in plant roots and act to extend the reach of root hairs into the soil. Mycorrhizae increase the uptake of water and nutrients, especially phosphorus. They are particularly important in degraded or less fertile soils. Roots colonized by mycorrhizae are less likely to be penetrated by root-feeding nematodes, since the pest cannot pierce the thick fungal network. Mycorrhizae also produce hormones and antibiotics that enhance root growth and provide disease suppression. The fungi benefit by taking nutrients and carbohydrates from the plant roots they live in.

### Actinomycetes

Actinomycetes (ac-tin-o-my'-cetes) are thread-like bacteria that look like fungi. While not as numerous as bacteria, they too perform vital roles in the soil. Like the bacteria, they help decompose organic matter into humus, releasing nutrients. They also produce antibiotics to fight diseases of roots. Many of these same antibiotics are used to treat human diseases. Actinomycetes are responsible for the sweet, earthy smell noticed whenever a biologically active soil is tilled.

### Algae

Many different species of algae live in the upper half-inch of the soil. Unlike most other soil organisms, algae produce their own food through photosynthesis. They appear as a greenish film on the soil surface following a saturating rain. Algae improve soil structure by producing slimy substances that glue soil together into water-stable aggregates. Some species of algae (the blue-greens) can fix their own nitrogen, some of which is later released to plant roots.

### Protozoa

Protozoa are free-living microorganisms that crawl or swim in the water between soil particles. Many soil protozoa are predatory, eating other microbes. One of the most common is an amoeba that eats bacteria. By eating and digesting bacteria, protozoa speed up the cycling of nitrogen from the bacteria, making it more available to plants.

### Nematodes

Nematodes are abundant in most soils, and only a few species are harmful to plants. The harmless species eat decaying plant litter, bacteria, fungi, algae, protozoa, and other nematodes. Like other soil predators, nematodes speed the rate of nutrient cycling.

### Soil organisms and soil quality

All these organisms—from the tiny bacteria up to the large earthworms and insects—interact with one another in a multitude of ways in the soil ecosystem. Organisms not directly involved in decomposing plant wastes may feed on each other or each other's waste products or the other substances they release. Among the substances released by the various microbes are vitamins, amino acids, sugars, antibiotics, gums, and waxes.

---

**Research on life in the soil has determined that there are ideal ratios for certain key organisms in highly productive soils.**

---

Roots can also release into the soil various substances that stimulate soil microbes. These substances serve as food for select organisms. Some scientists and practitioners theorize that

plants use this means to stimulate the specific population of microorganisms capable of releasing or otherwise producing the kind of nutrition needed by the plants.

Research on life in the soil has determined that there are ideal ratios for certain key organisms in highly productive soils (9). The Soil Foodweb Lab, located in Oregon, tests soils and makes fertility recommendations that are based on this understanding. Their goal is to alter the makeup

of the soil microbial community so it resembles that of a highly fertile and productive soil. There are several different ways to accomplish this goal, depending on the situation. For more on the Soil Foodweb Lab, see the **Additional Resources** section of this publication.

Because we cannot see most of the creatures living in the soil and may not take time to observe the ones we can see, it is easy to forget about them. See [Table 4](#) for estimates of typical amounts of various organisms found in fertile soil. There are many Web sites that provide in-depth information on soil organisms. Look for a list of these Web sites in the **Additional Resources** section. Many of these sites have color photographs of soil organisms and describe their benefits to soil fertility and plant growth.

**Table 4. Weights of soil organisms in the top 7 inches of fertile soil.**

Organism	Pounds of liveweight/acre
Bacteria	1000
Actinomycetes	1000
Molds	2000
Algae	100
Protozoa	200
Nematodes	50
Insects	100
Worms	1000
Plant roots	2000

From Bollen (10).

## Organic Matter, Humus, and the Soil Foodweb

Like cattle and other farm animals, soil livestock require proper feed.

Understanding the role that soil organisms play is critical to sustainable soil management. Based on that understanding, focus can be directed toward strategies that build both the numbers and the diversity of soil organisms. Like cattle and other farm animals, soil livestock require proper feed. That feed comes in the form of organic matter.

*Organic matter* and *humus* are terms that describe somewhat different but related things. Organic matter refers to the fraction of the soil that is composed of both living organisms and once-living residues in various stages of decomposition. Humus is only a small portion of the organic matter. It is the end product of organic matter decomposition and is relatively stable. Further decomposition of humus occurs very slowly in both agricultural and natural settings. In natural systems, a balance is reached between the amount of humus formation and the amount of humus decay (11). This balance also occurs in most agricultural soils, but often at a much lower level of soil humus. Humus contributes to well-structured soil that, in turn, produces high-quality plants. It is clear that management of organic matter and humus is essential to sustaining the whole soil ecosystem.

The benefits of a topsoil rich in organic matter and humus are many. They include rapid decomposition of crop residues, granulation of soil into water-stable aggregates, decreased crusting and clodding, improved internal drainage, better water infiltration, and increased water and nutrient holding capacity. Improvements in the soil's physical structure facilitate easier tillage, increased water storage capacity, reduced erosion, better formation and harvesting of root crops, and deeper, more prolific plant root systems.

Soil organic matter can be compared to a bank account for plant nutrients. Soil containing 4% organic matter in the top seven inches has 80,000 pounds of organic matter per acre. That 80,000 pounds of organic matter will contain about 5.25% nitrogen, amounting to 4,200 pounds of nitrogen per acre. Assuming a 5% release rate during the growing season, the organic matter could supply 210 pounds of nitrogen to a crop. However, if the organic matter is allowed to degrade and lose nitrogen, purchased fertilizer will be necessary to prop up crop yields.

All the soil organisms mentioned previously, except algae, depend on organic matter as their food source. Therefore, to maintain their populations, organic matter must be renewed from plants growing on the soil, or from animal manure, compost, or other materials imported from

off site. When soil livestock are fed, fertility is built up in the soil, and the soil will feed the plants.

Ultimately, building organic matter and humus levels in the soil is a matter of managing the soil's living organisms—something akin to wildlife management or animal husbandry. This entails working to maintain favorable conditions of moisture, temperature, nutrients, pH, and aeration. It also involves providing a steady food source of raw organic material.

---

**Ultimately, building organic matter and humus in the soil is a matter of managing the soil's living organisms.**

---

these aggregates become wet again, however, their stability is challenged, and they may break apart. Aggregates can also be held together by plant roots, earthworm activity, and by glue-like products pro-

duced by soil microorganisms. Earthworm-created aggregates are stable once they come out of the worm. An aggregate formed by physical forces can be bound together by fine root hairs or threads produced by fungi.

Aggregates can also become stabilized (remain intact when wet) through the by-products of organic matter decomposition by fungi and bacteria—chiefly gums, waxes, and other glue-like substances. These by-products cement the soil particles together, forming water-stable aggregates (Figure 2). The aggregate is then strong enough to hold together when wet—hence the term “water-stable.”

USDA soil microbiologist Sara Wright named the glue that holds aggregates together “glomalin” after the Glomales group of common root-dwelling fungi (12). These fungi secrete a gooey protein known as glomalin through their hair-like filaments, or hyphae. When Wright measured glomalin in soil aggregates she found levels as high as 2% of their total weight in eastern U.S. soils. Soil aggregates from the West and Midwest had lower levels of glomalin. She found that tillage tends to lower glomalin levels. Glomalin levels and aggregation were

## Soil Tilth and Organic Matter

A soil that drains well, does not crust, takes in water rapidly, and does not make clods is said to have good tilth. Tilth is the physical condition of the soil as it relates to tillage ease, seed-bed quality, easy seedling emergence, and deep root penetration. Good tilth is dependent on aggregation—the process whereby individual soil particles are joined into clusters or “aggregates.”

Aggregates form in soils when individual soil particles are oriented and brought together through the physical forces of wetting and drying or freezing and thawing. Weak electrical forces from calcium and magnesium hold soil particles together when the soil dries. When

MICROBIAL AND FUNGAL  
BYPRODUCTS GLUE  
THE PARTICLES TOGETHER

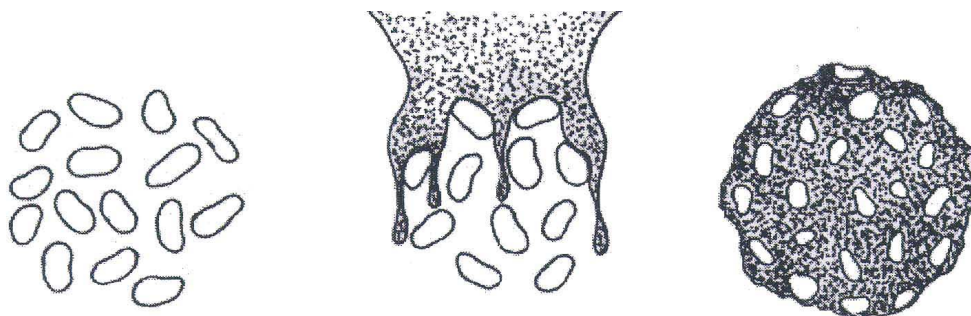

DISPERSED STATE

AGGREGATED STATE

Figure 2. Microbial byproducts glue soil particles into water-stable aggregates.



higher in no-till corn plots than in tilled plots (12). Wright has a brochure describing glomalin and how it benefits soil, entitled *Glomalin, a Manageable Soil Glue*. To order this brochure see the **Additional Resources** section of this publication.

A well-aggregated soil allows for increased water entry, increased air flow, and increased water-holding capacity (13). Plant roots occupy a larger volume of well-aggregated soil, high in organic matter, as compared to a finely pulverized and dispersed soil, low in organic matter. Roots, earthworms, and soil arthropods can pass more easily through a well-aggregated soil (14). Aggregated soils also prevent crusting of the soil surface. Finally, well-aggregated soils are more erosion resistant, because aggregates are much heavier than their particle components. For a good example of the effect of organic matter additions on aggregation, as shown by subsequent increase in water entry into the soil, see Table 5.

**Table 5. Water entry into the soil after 1 hour**

Manure Rate (tons/acre)	Inches of water
0	1.2
8	1.9
16	2.7

Boyle et al. (13).

The opposite of aggregation is dispersion. In a dispersed soil, each individual soil particle is free to blow away with the wind or wash away with overland flow of water.

Clay soils with poor aggregation tend to be sticky when wet, and cloddy when dry. If the clay particles in these soils can be aggregated together, better aeration and water infiltration will result. Sandy soils can benefit from aggregation by having a small amount of dispersed clay that tends to stick between the sand particles and slow the downward movement of water.

Crusting is a common problem on soils that are poorly aggregated. Crusting results chiefly from the impact of falling raindrops. Rainfall causes clay particles on the soil surface to disperse and

clog the pores immediately beneath the surface. Following drying, a sealed soil surface results in which most of the pore space has been drastically reduced due to clogging from dispersed clay particles. Subsequent rainfall is much more likely to run off than to flow into the soil (Figure 3).

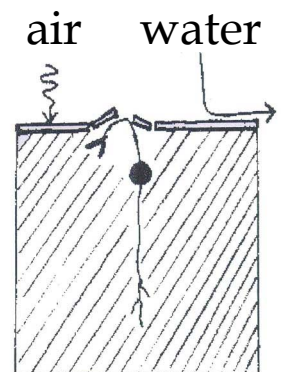

Crusted

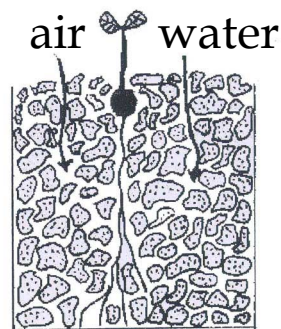

Well-Aggregated

Figure 3. Effects of aggregation on water and air entry into the soil.

Derived from Land Stewardship Project Monitoring Toolbox (15).

Since raindrops start crusting, any management practices that protect the soil from their impact will decrease crusting and increase water flow into the soil. Mulches and cover crops serve this purpose well, as do no-till practices, which allow the accumulation of surface residue. Also, a well-aggregated soil will resist crusting because the water-stable aggregates are less likely to break apart when a raindrop hits them.

Long-term grass production produces the best-aggregated soils (16). A grass sod extends a mass of fine roots throughout the topsoil, con-

tributing to the physical processes that help form aggregates. Roots continually remove water from soil microsites, providing local wetting and drying effects that promote aggregation. Fine root hairs also bind soil aggregates together.

Roots also produce food for soil microorganisms and earthworms, which in turn generate compounds that bind soil particles into water-stable aggregates. In addition, perennial grass sods provide protection from raindrops and erosion. Thus, a perennial cover creates a combination of conditions optimal for the creation and maintenance of well-aggregated soil.

Conversely, cropping sequences that involve annual plants and extensive cultivation provide less vegetative cover and organic matter, and usually result in a rapid decline in soil aggregation. For more information on aggregation, see the soil quality information sheet entitled *Aggregate Stability* at the Soil Quality Institute's home page, <[http://soils.usda.gov/sqi/files/sq\\_eig\\_1.pdf](http://soils.usda.gov/sqi/files/sq_eig_1.pdf)>. From there, click on Soil Quality Information Sheets, then click on Aggregate Stability.

Farming practices can be geared to conserve and promote soil aggregation. Because the binding substances are themselves susceptible to microbial degradation, organic matter needs to be replenished to maintain microbial populations and overall aggregated soil status. Practices should conserve aggregates once they are formed, by minimizing factors that degrade and destroy aggregation. Some factors that destroy or degrade soil aggregates are:

- bare soil surface exposed to the impact of raindrops
- removal of organic matter through crop production and harvest without return of organic matter to the soil
- excessive tillage
- working the soil when it is too wet or too dry
- use of anhydrous ammonia, which speeds up decomposition of organic matter
- excess nitrogen fertilization

- allowing the build-up of excess sodium from irrigation or sodium-containing fertilizers

## Tillage, Organic Matter, and Plant Productivity

---

**The best-aggregated soils are those that have been in long-term grass production.**

---

Several factors affect the level of organic matter that can be maintained in a soil. Among these are organic matter additions, moisture, temperature,

tillage, nitrogen levels, cropping, and fertilization. The level of organic matter present in the soil is a direct function of how much organic material is being produced or added to the soil versus the rate of decomposition. Achieving this balance entails slowing the speed of organic matter decomposition, while increasing the supply of organic materials produced on site and/or added from off site.

Moisture and temperature also profoundly affect soil organic matter levels. High rainfall and temperature promote rapid plant growth, but these conditions are also favorable to rapid organic matter decomposition and loss. Low rainfall or low temperatures slow both plant growth and organic matter decomposition. The native Midwest prairie soils originally had a high amount of organic matter from the continuous growth and decomposition of perennial grasses, combined with a moderate temperature that did not allow for rapid decomposition of organic matter. Moist and hot tropical areas may appear lush because of rapid plant growth, but soils in these areas are low in nutrients. Rapid decomposition of organic matter returns nutrients back to the soil, where they are almost immediately taken up by rapidly growing plants.

Tillage can be beneficial or harmful to a biologically active soil, depending on what type of tillage is used and when it is done. Tillage affects both erosion rates and soil organic matter decomposition rates. Tillage can reduce the organic matter level in croplands below 1%, rendering them biologically dead. Clean tillage involving moldboard plowing and disking breaks down soil aggregates and leaves the soil prone to erosion from wind and water. The moldboard plow can bury crop residue and topsoil to a depth of 14 inches. At this depth, the oxy-

gen level in the soil is so low that decomposition cannot proceed adequately. Surface-dwelling decomposer organisms suddenly find themselves suffocated and soon die. Crop residues that were originally on the surface but now have been turned under will putrefy in the oxygen-deprived zone. This rotting activity may give a putrid smell to the soil. Furthermore, the top few inches of the field are now often covered with subsoil having very little organic matter content and, therefore, limited ability to support productive crop growth.

The topsoil is where the biological activity happens—it's where the oxygen is. That's why a fence post rots off at the surface. In terms of organic matter, tillage is similar to opening the air vents on a wood-burning stove; adding organic matter is like adding wood to the stove. Ideally, organic matter decomposition should proceed as an efficient burn of the "wood" to release nutrients and carbohydrates to the soil organisms and create stable humus. Shallow tillage incorporates residue and speeds the decomposition of organic matter by adding oxygen that microbes need to become more active.

In cold climates with a long dormant season, light tillage of a heavy residue may be beneficial; in warmer climates it is hard enough to maintain organic matter levels without any tillage.

As indicated in Figure 4, moldboard plowing causes the fastest decline of organic matter, no-till the least. The plow lays the soil up on its side, increasing the surface area exposed to oxygen. The other three types of tillage are intermediate in their ability to foster organic matter decomposition. Oxygen is the key factor here. The moldboard plow increases the soil surface area, allowing more air into the soil and speeding the decomposition rate. The horizontal line on Figure 4 represents the replenishment of organic matter provided by wheat stubble. With the moldboard plow, more than the entire organic matter contribution from the wheat straw is gone within only 19 days following tillage. Finally, the passage of heavy equipment increases compaction in the wheel tracks, and some tillage implements themselves compact the soil further, removing oxygen and increasing the chance that deeply buried residues will putrefy.

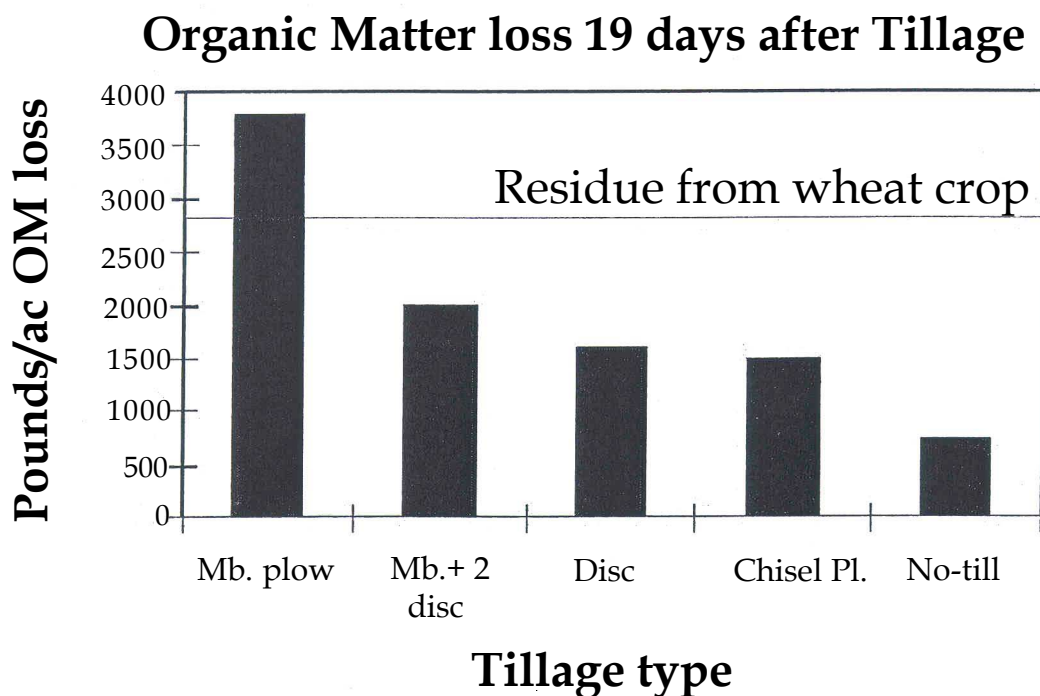

Reicosky & Lindstrom, 1995

Figure 4. Organic matter losses after various tillage practices (17).

Tillage also reduces the rate of water entry into the soil by removal of ground cover and destruction of aggregates, resulting in compaction and crusting. Table 6 shows three different tillage methods and how they affect water entry into the soil. Notice the direct relationship between tillage type, ground cover, and water infiltration. No-till has more than three times the water infiltration of the moldboard-plowed soil. Additionally, no-till fields will have higher aggregation from the organic matter decomposition on site. The surface mulch typical of no-till fields acts as a protective skin for the soil. This soil skin reduces the impact of raindrops and buffers the soil from temperature extremes as well as reducing water evaporation.

**Table 6. Tillage effects on water infiltration and ground cover.**

	Water Infiltration mm/minute	Ground Cover Percent
No-till	2.7	48
Chisel Plow	1.3	27
Moldboard Plow	0.8	12

From Boyle et al., 1989 (13).

Both no-till and reduced-tillage systems provide benefits to the soil. The advantages of a no-till system include superior soil conservation, moisture conservation, reduced water runoff, long-term buildup of organic matter, and increased water infiltration. A soil managed without tillage relies on soil organisms to take over the job of plant residue incorporation formerly done by tillage. On the down side, no-till can foster a reliance on herbicides to control weeds and can lead to soil compaction from the traffic of heavy equipment.

Pioneering development work on chemical-free no-till farming is proceeding at several research stations and farms in the eastern U.S. Pennsylvania farmer Steve Groff has been farming no-till with minimal or no herbicides for several years. Groff grows cover crops extensively in his fields, rolling them down in the spring using a 10-foot rolling stalk chopper. This rolling chopper kills the rye or vetch cover crop and creates a nice no-till mulch into which he plants a variety of vegetable and grain crops. After several years of no-till production, his soils are mellow and easy to plant into. Groff farms 175

acres of vegetables, alfalfa, and grain crops on his Cedar Meadow Farm. Learn more about his operation in the **Farmer Profiles** section of this publication, by visiting his Web site, or by ordering his video (see **Additional Resources** section).

Other conservation tillage systems include ridge tillage, minimum tillage, zone tillage, and reduced tillage, each possessing some of the advantages of both conventional till and no-till. These systems represent intermediate tillage systems, allowing more flexibility than either a no-till or conventional till system might. They are more beneficial to soil organisms than a conventional clean-tillage system of moldboard plowing and disking.

Adding manure and compost is a recognized means for improving soil organic matter and humus levels. In their absence, perennial grass is the only crop that can regenerate and increase soil humus (18). Cool-season grasses build soil organic matter faster than warm-season grasses because they are growing much longer during a given year (18). When the soil is warm enough for soil organisms to decompose organic matter, cool-season grass is growing. While growing, it is producing organic matter and cycling minerals from the decomposing organic matter in the soil. In other words, there is a net gain of organic matter because the cool-season grass is producing organic matter faster than it is being used up. With warm-season grasses, organic matter production during the growing season can be slowed during the long dormant season from fall through early spring. During the beginning and end of this dormant period, the soil is still biologically active, yet no grass growth is proceeding (18). Some net accumulation of organic matter can occur under warm-season grasses, however. In a Texas study, switchgrass (a warm-season grass) grown for four years increased soil carbon content from 1.1% to 1.5% in the top 12 inches of soil (19). In hot and moist regions, a cropping rotation that includes several years of pasture will be most beneficial.

### Effect of Nitrogen on Organic Matter

Excessive nitrogen applications stimulate increased microbial activity, which in turn speeds organic matter decomposition. The extra nitro-

gen narrows the ratio of carbon to nitrogen in the soil. Native or uncultivated soils have approximately 12 parts of carbon to each part of nitrogen, or a C:N ratio of 12:1. At this ratio, populations of decay bacteria are kept at a stable level (20), since additional growth in their population is limited by a lack of nitrogen. When large amounts of inorganic nitrogen are added, the C:N ratio is reduced, which allows the populations of decay organisms to explode as they decompose more organic matter with the now abundant nitrogen. While soil bacteria can efficiently use moderate applications of inorganic nitrogen accompanied by organic amendments (carbon), excess nitrogen results in decomposition of existing organic matter at a rapid rate. Eventually, soil carbon content may be reduced to a level where the bacterial populations are on a starvation diet. With little carbon available, bacterial populations shrink, and less of the free soil nitrogen is absorbed. Thereafter, applied nitrogen, rather than being cycled through microbial organisms and re-released to plants slowly over time, becomes subject to leaching. This can greatly reduce the efficiency of fertilization and lead to environmental problems.

---

**Excessive nitrogen stimulates increased microbial activity, which in turn speeds organic matter decomposition.**

---

To minimize the fast decomposition of soil organic matter, carbon should be added with nitrogen. Typical carbon sources—such as green manures, animal manure, and compost—serve this purpose well.

Amendments containing too high a carbon to nitrogen ratio (25:1 or more) can tip the balance the other way, resulting in nitrogen being tied up in an unavailable form. Soil organisms consume all the nitrogen in an effort to decompose the abundant carbon; tied up in the soil organisms, nitrogen remains unavailable for plant uptake. As soon as a soil microorganism dies and decomposes, its nitrogen is consumed by another soil organism, until the balance between carbon and nitrogen is achieved again.

## Fertilizer Amendments and Biologically Active Soils

What are the soil mineral conditions that foster biologically active soils? Drawing from the work of Dr. William Albrecht (1888 to 1974), agronomist at the University of Missouri, we learn that balance is the key. Albrecht advocated bringing soil nutrients into a balance so that none were in excess or deficient. Albrecht's theory (also called base-saturation theory) is used to guide lime and fertilizer application by measuring and evaluating the ratios of positively charged nutrients (bases) held in the soil. Positively charged bases include calcium, magnesium, potassium, sodium, ammonium nitrogen, and several trace minerals. When optimum ratios of bases exist, the soil is believed to support high biological activity, have optimal physical properties (water intake and aggregation), and become resistant to leaching. Plants growing on such a soil are also balanced in mineral levels and are considered to be nutritious to humans and animals alike. Base saturation percentages that Albrecht's research showed to be optimal for the growth of most crops are:

Calcium	60–70%
Magnesium	10–20%
Potassium	2–5%
Sodium	0.5–3%
Other bases	5%

According to Albrecht, fertilizer and lime applications should be made at rates that will bring soil mineral percentages into this ideal range. This approach will shift the soil pH automatically into a desirable range without creating nutrient imbalances. The base saturation theory also takes into account the effect one nutrient may have on another and avoids undesirable interactions. For example, phosphorus is known to tie up zinc.

The Albrecht system of soil evaluation contrasts with the approach used by many state laboratories, often called the "sufficiency method." Sufficiency theory places little to no value on nutrient ratios, and lime recommendations are typically based on pH measurements alone. While in many circumstances base saturation and sufficiency methods will produce identical

soil recommendations and similar results, significant differences can occur on a number of soils. For example, suppose we tested a cornfield and found a soil pH of 5.5 and base saturation for magnesium at 20% and calcium at 40%. Base saturation theory would call for liming with a high-calcium lime to raise the percent base saturation of calcium; the pH would rise accordingly. Sufficiency theory would not specify high-calcium lime and the grower might choose instead a high-magnesium dolomite lime that would raise the pH but worsen the balance of nutrients in the soil. Another way to look at these two theories is that the base saturation theory does not concern itself with pH to any great extent, but rather with the proportional amounts of bases. The pH will be correct when the levels of bases are correct.

Albrecht's ideas have found their way onto large numbers of American farms and into the programs of several agricultural consulting companies. Neal Kinsey, a soil fertility consultant in Charleston, Missouri, is a major proponent of the Albrecht approach. Kinsey was a student under Albrecht and is one of the leading authorities on the base-saturation method. He teaches a short course on the Albrecht system and provides a soil analysis service (21). His book, *Hands On Agronomy*, is widely recognized as a highly practical guide to the Albrecht system. ATTRA can provide more information on Albrecht Fertility Management Systems.

Several firms—many providing backup fertilizer and amendment products—offer a biological-farming program based on the Albrecht theory. Typically these firms offer broad-based soil analysis and recommend balanced fertilizer materials considered friendly to soil organisms. They avoid the use of some common fertilizers and amendments such as dolomite lime, potassium chloride, anhydrous ammonia, and oxide forms of trace elements because they are considered harmful to soil life. The publication *How to Get Started in Biological Farming* presents such a program. See the **Additional Resources** section for ordering information. For names of companies offering consulting and products, order the ATTRA publications *Alternative Soil Testing*

*Laboratories* and *Sources of Organic Fertilizers and Amendments*. Both of these are also available on the ATTRA Web site located at <<http://www.attra.ncat.org>>.

## Conventional Fertilizers

Commercial fertilizer can be a valuable resource to farmers in transition to a more sustainable system and can help meet nutrient needs during times of high crop nutrient demand or when weather conditions result in slow nutrient release from organic resources. Commercial fertilizers have the advantage of supplying plants with immediately available forms of nutrients. They are often less expensive and less bulky to apply than many natural fertilizers.

Not all conventional fertilizers are alike. Many appear harmless to soil livestock, but some are not. Anhydrous ammonia contains approximately 82% nitrogen and is applied subsurface as a gas. Anhydrous speeds the decomposition of organic matter in the soil, leaving the soil more compact as a result. The addition of anhydrous causes increased acidity in the soil, requiring 148 pounds of lime to neutralize 100 pounds of anhydrous ammonia, or 1.8 pounds of lime for every pound of nitrogen contained in the anhydrous (22). Anhydrous ammonia initially kills many soil microorganisms in the application zone. Bacteria and actinomycetes recover within one to two weeks to levels higher than those prior to treatment (23). Soil fungi, however, may take seven weeks to recover. During the recovery time, bacteria are stimulated to grow more, and decompose more organic matter, by the high soil nitrogen content. As a result, their numbers increase after anhydrous applications, then decline as available soil organic matter is depleted. Farmers commonly report that the long-term use of synthetic fertilizers, especially anhydrous ammonia, leads to soil compaction and poor tilth (23). When bacterial populations and soil organic matter decrease, aggregation declines, because existing glues that stick soil particles together are degraded, and no other glues are being produced.

Potassium chloride (KCl) (0-0-60 and 0-0-50), also known as muriate of potash, contains approximately 50 to 60% potassium and 47.5% chloride (24). Muriate of potash is made by refining potassium chloride ore, which is a mixture of potassium and sodium salts and clay from the brines of drying lakes and seas. The potential harmful effects from KCl can be surmised from the salt concentration of the material. Table 7 shows that, pound for pound, KCl is surpassed only by table salt on the salt index. Additionally, some plants such as tobacco, potatoes, peaches, and some legumes are especially sensitive to chloride. High rates of KCl must be avoided on such crops. Potassium sulfate, potassium nitrate, sul-po-mag, or organic sources of potassium may be considered as alternatives to KCl for fertilization.

Sodium nitrate, also known as Chilean nitrate or nitrate of soda, is another high-salt fertilizer. Because of the relatively low nitrogen content of sodium nitrate, a high amount of sodium is added to the soil when normal applications of nitrogen are made with this material. The concern is that excessive sodium acts as a dispersant of soil particles, degrading aggregation. The salt index for KCl and sodium nitrate can be seen in Table 7.

**Protecting soil from erosion is the first step toward a sustainable agriculture.**

## Top\$oil – Your Farm’s Capital

Topsoil is the capital reserve of every farm. Ever since mankind started agriculture, erosion of topsoil has been the single largest threat to a

**Table 7. Salt index for various fertilizers.**

Material	Salt Index	Salt index per unit of plant food
Sodium chloride	153	2.9
Potassium chloride	116	1.9
Ammonium nitrate	105	3.0
Sodium nitrate	100	6.1
Urea	75	1.6
Potassium nitrate	74	1.6
Ammonium sulfate	69	3.3
Calcium nitrate	53	4.4
Anhydrous ammonia	47	.06
Sulfate-potash-magnesia	43	2.0
Di-ammonium phosphate	34	1.6
Monammonium phosphate	30	2.5
Gypsum	8	.03
Calcium carbonate	5	.01

soil's productivity – and, consequently, to farm profitability. This is still true today. In the U.S., the average acre of cropland is eroding at a rate of 7 tons per year (2). To sustain agriculture means to sustain soil resources, because that's the source of a farmer's livelihood.

The major productivity costs to the farm associated with soil erosion come from the replacement of lost nutrients and reduced water holding ability, accounting for 50 to 75% of productivity loss (2). Soil that is removed by erosion typically contains about three times more nutrients than the soil left behind and is 1.5 to 5 times richer in organic matter (2). This organic matter loss not only results in reduced water holding capacity and degraded soil aggregation, but also loss of plant nutrients, which must then be replaced with nutrient amendments.

Five tons of topsoil (the so-called tolerance level) can easily contain 100 pounds of nitrogen, 60 pounds of phosphate, 45 pounds of potash, 2 pounds of calcium, 10 pounds of magnesium, and 8 pounds of sulfur. Table 8 shows the effect of slight, moderate, and severe erosion on organic matter, soil phosphorus level, and plant-available water on a silt loam soil in Indiana (25).

Water erosion gets started when falling rainwater collides with bare ground and detaches soil particles from the parent soil body. After enough water builds up on the soil surface, following detachment, overland water flow transports suspended soil down-slope (Figure 5). Suspended soil in the runoff water abrades and detaches additional soil particles as the water travels overland. Preventing detachment is the most effective point of erosion control because it keeps the soil in place. Other erosion control practices seek to slow soil particle transport and cause soil to be deposited before it reaches streams. These methods are less effective at protecting the quality of soil within the field.

Commonly implemented practices to slow soil transport include terraces and diversions. Terraces, diversions, and many other erosion "control" practices are largely unnecessary if the ground stays covered year-round. For erosion prevention, a high percentage of ground cover is a good indicator of success, while bare ground is an "early warning" indicator for a high risk of erosion (27). Muddy runoff water and gullies are "too-late" indicators. The soil has already eroded by the time it shows up as muddy water, and it's too late to save soil already suspended in the water.

**Table 8. Effect of erosion on organic matter phosphorus and plant-available water.**

Erosion level	Organic matter	Phosphorus	Plant-available water
	%	Lbs./ac	%
Slight	3.0	62	7.4
Moderate	2.5	61	6.2
Severe	1.9	40	3.6

From Schertz et al., 1984. (24)

When erosion by water and wind occurs at a rate of 7.6 tons/acre/year it costs \$40 per acre each year to replace the lost nutrients as fertilizer and around \$17/acre/year to pump well irrigation water to replace the soil water holding capacity of that lost soil (26). The total cost of soil and water lost annually from U.S. cropland amounts to an on-site productivity loss of approximately \$27 billion each year (2).

Protecting the soil from erosion is *the* first step toward a sustainable agriculture. Since water erosion is initiated by raindrop impact on bare soil, any management practice that protects the soil from raindrop impact will decrease erosion and increase water entry into the soil. Mulches, cover crops, and crop residues serve this purpose well.



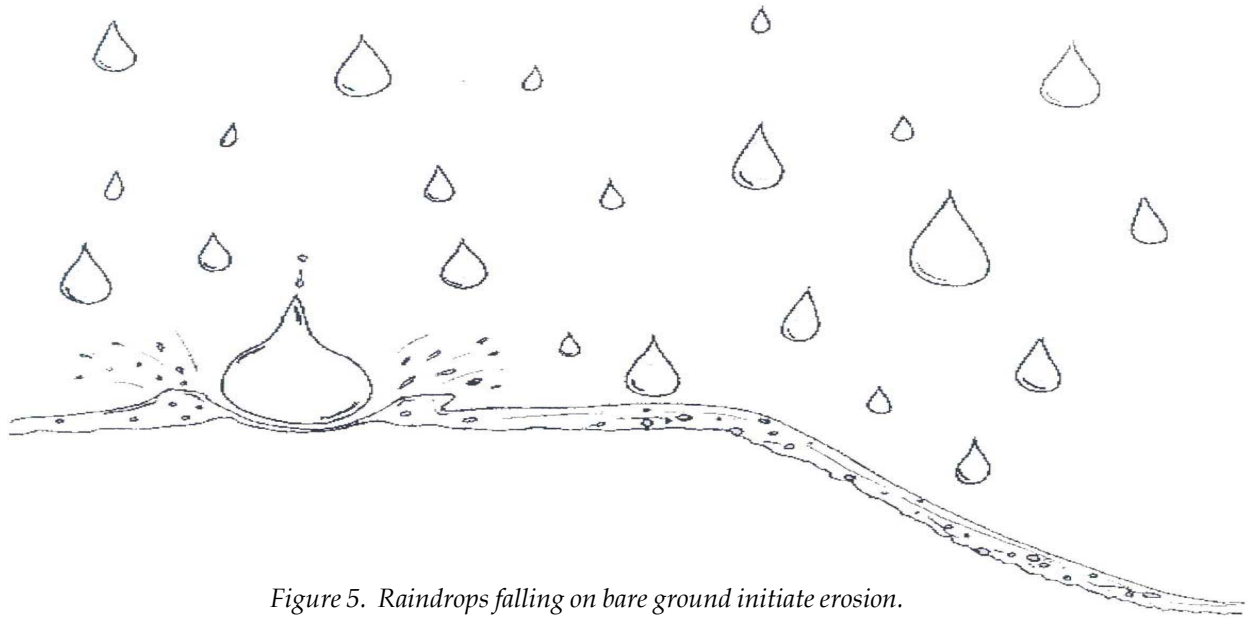

Figure 5. Raindrops falling on bare ground initiate erosion.  
Drawing from cropland monitoring guide (27).

Additionally, well-aggregated soils resist crusting because water-stable aggregates are less likely to break apart when the raindrop hits them. Adequate organic matter with high soil biological activity leads to high soil aggregation.

Many studies have shown that cropping systems that maintain a soil-protecting plant canopy or residue cover have the least soil erosion. This is universally true. Long-term cropping studies begun in 1888 at the University of Missouri provide dramatic evidence of this. Gantzer and colleagues (28) examined the effects of a century of cropping on soil erosion. They compared depth of topsoil remaining after 100 years of cropping (Table 9). As the table shows, the cropping system that maintained the highest amount of permanent ground cover (timothy grass) had the greatest amount of topsoil left.

**Table 9. Topsoil depth remaining after 100 years of different cropping practices.**

Crop Sequence	Inches of topsoil remaining
Continuous Corn	7.7
6-year rotation*	12.2
Continuous timothy grass	17.4

\*Corn, oats, wheat, clover, timothy  
From: Gantzer et al. (28).

The researchers commented that subsoil had been mixed with topsoil in the continuous corn plots from plowing, making the real topsoil depth less than was apparent. In reality, all the topsoil was lost from the continuous corn plots in only 100 years. The rotation lost about half the topsoil over 100 years. How can we feed future generations with this type of farming practice?

In a study of many different soil types in each of the major climatic zones of the U.S., researchers showed dramatic differences in soil erosion when comparing row crops to perennial sods. Row crops consisted of cotton or corn, and sod crops were bluegrass or bermuda grass. On average, the row crops eroded more than 50 times more soil than did the perennial sod crops. The two primary influencing factors are ground cover and tillage. The results are shown in Table 10.

So, how long do fields have before the topsoil is gone? This depends on where in the country the field is located. Some soils naturally have very thick topsoil, while other soils have thin topsoil over rock or gravel. Roughly 8 tons/acre/year of soil-erosion loss amounts to the thickness of a dime spread over an acre. Twenty dimes stack up to 1-inch high. So a landscape with an 8-ton erosion rate would lose an inch of topsoil about every 20 years. On a soil with a thick topsoil, this amount is barely detectable within a person's lifetime and may not be no-

**Table 10. Effect of cropping on soil erosion rates**

Soil type	Location	Slope	Row crop soil loss	Sod soil loss
	<i>State</i>	<i>%</i>	<i>Tons/ac</i>	<i>Tons/ac</i>
Silt loam	Iowa	9	38	.02
Loam	Missouri	8	51	.16
Silt loam	Ohio	12	99	.02
Fine sandy loam	Oklahoma	7.7	19	.02
Clay loam	N. Carolina	10	31	.31
Fine sandy loam	Texas	8.7	24	.08
Clay	Texas	4	21	.02
Silt loam	Wisconsin	16	111	.10
Average	Average	9.4	49	.09

*Adapted from Shiflet and Darby, 1985 (29).*

ticed. Soils with naturally thin topsoils or topsoils that have been previously eroded can be transformed from productive to degraded land within a generation.

Forward-thinking researcher Wes Jackson, of the Land Institute, waxes eloquent about how tillage has become engrained in human culture since we first began farming. Beating our swords into plowshares surely embodies the triumph of good over evil. Someone who creates something new is said to have “plowed new ground.” “Yet the plowshare may well have destroyed more options for future generations than the sword” (30).

Tillage for the production of annual crops is the major problem in agriculture, causing soil erosion and the loss of soil quality. Any agricultural practice that creates and maintains bare ground is inherently less sustainable than practices that keep the ground covered throughout the year. Wes Jackson has spent much of his career developing perennial grain crops and cropping systems that mimic the natural prairie. Perennial grain crops do not require tillage to establish year after year, and the ground is left covered. Ultimately, this is the future of grain production and truly represents a new vision for how we produce food. The greatest research need in agriculture today is breeding work to develop perennial crops that will replace annual crops requiring tillage. Farming practices using annual crops in ways that mimic perennial

systems, such as no-till and cover crops, are our best alternative until perennial systems are developed.

## Summary of Part I

Soil management involves stewardship of the soil livestock herd. The primary factors affecting organic matter content, build-up, and decomposition rate in soils are oxygen content, nitrogen content, moisture content, temperature, and the addition and removal of organic materials. All these factors work together all the time. Any one can limit the others. These are the factors that affect the health and reproductive rate of organic matter decomposer organisms. Managers need to be aware of these factors when making decisions about their soils. Let’s take them one at a time.

*Increasing oxygen* speeds decomposition of organic matter. Tillage is the primary way extra oxygen enters the soil. Texture also plays a role, with sandy soils having more aeration than heavy clay soils. *Nitrogen content* is influenced by fertilizer additions. Excess nitrogen, without the addition of carbon, speeds the decomposition of organic matter. *Moisture content* affects decomposition rates. Soil microbial populations are most active over cycles of wetting and drying. Their populations increase following wetting, as the soil dries out. After the soil becomes dry, their activity diminishes. Just like

humans, soil organisms are profoundly affected by *temperature*. Their activity is highest within a band of optimum temperature, above and below which their activity is diminished.

*Adding organic matter* provides more food for microbes. To achieve an increase of soil organic matter, additions must be higher than removals. Over a given year, under average conditions, 60 to 70 percent of the carbon contained in organic residues added to soil is lost as carbon dioxide (20). Five to ten percent is assimilated into the organisms that decomposed the organic residues, and the rest becomes 'new' humus. It takes decades for new humus to develop into stable humus, which imparts the nutrient-holding characteristics humus is known for (20). The end result of adding a ton of residue would be 400 to 700 pounds of new humus. One percent organic matter weighs 20,000 pounds per acre. A 7-inch depth of topsoil over an acre weighs 2 million pounds. Building organic matter is a *slow* process.

It is more feasible to stabilize and maintain the humus present, before it is lost, than to try to rebuild it. The value of humus is not fully realized until it is severely depleted (20). If your soils are high in humus now, work hard to preserve what you have. The formation of new humus is essential to maintaining old humus, and the decomposition of raw organic matter has many benefits of its own. Increased aeration caused by tillage coupled with the absence of organic carbon in fertilizer materials has caused more than a 50% decline in native humus levels on many U.S. farms (20).

Appropriate mineral nutrition needs to be present for soil organisms and plants to prosper. Adequate levels of calcium, magnesium, potassium, phosphorus, sodium, and the trace elements should be present, but not in excess. The base saturation theory of soil management helps guide decision-making toward achieving optimum levels of these nutrients in the soil. Several books have been written on balancing soil mineral levels, and several consulting firms provide soil analysis and fertility recommendation services based on this theory.

Commercial fertilizers have their place in sustainable agriculture. Some appear harmless to soil livestock and provide nutrients at times of high nutrient demand from crops. Anhydrous ammonia and potassium chloride cause problems, however. As noted above, anhydrous kills soil organisms in the injection zone. Bacteria and actinomycetes recover within a few weeks, but fungi take longer. The increase in bacteria, fed by highly available nitrogen from the anhydrous, speeds the decomposition of organic matter. Potassium chloride has a high salt index, and some plants and soil organisms are sensitive to chloride.

Topsoil is the farmer's capital. Sustaining agriculture means sustaining the soil. Maintaining ground cover in the form of cover crops, mulch, or crop residue for as much of the annual season as possible achieves the goal of sustaining the soil resource. Any time the soil is tilled and left bare it is susceptible to erosion. Even small amounts of soil erosion are harmful over time. It is not easy to see the effects of erosion over a human lifetime; therefore, erosion may go unnoticed. Tillage for production of annual crops has created most of the erosion associated with agriculture. Perennial grain crops not requiring tillage provide a promising alternative for drastically improving the sustainability of future grain production.

## Summary of Sustainable Soil Management Principles

- Soil livestock cycle nutrients and provide many other benefits.
- Organic matter is the food for the soil livestock herd.
- The soil should be covered to protect it from erosion and temperature extremes.
- Tillage speeds the decomposition of organic matter.
- Excess nitrogen speeds the decomposition of organic matter; insufficient nitrogen slows down organic matter decomposition and starves plants.

- Moldboard plowing speeds the decomposition of organic matter, destroys earthworm habitat, and increases erosion.
- To build soil organic matter, the production or addition of organic matter must exceed the decomposition of organic matter.
- Soil fertility levels need to be within acceptable ranges before a soil-building program is begun.



## PART II. MANAGEMENT STEPS TO IMPROVE SOIL QUALITY

### 1. Assess Soil Health and Biological Activity on Your Farm

A basic soil audit is the first and sometimes the only monitoring tool used to assess changes in the soil. Unfortunately, the standard soil test done to determine nutrient levels (P, K, Ca, Mg, etc.) provides no information on soil biology and physical properties. Yet most of the farmer-recognized criteria for healthy soils (see p. 2) include, or are created by, soil organisms and soil physical properties. A better appreciation of these biological and physical soil properties, and how they affect soil management and productivity, has resulted in the adoption of several new soil health assessment techniques, which are discussed below.

#### The USDA Soil Quality Test Kit

The USDA Soil Quality Institute provides a Soil Quality Test Kit Guide developed by Dr. John Doran and associates at the Agricultural Research Service's office in Lincoln, Nebraska. Designed for field use, the kit allows the measurement of water infiltration, water holding capacity, bulk density, pH, soil nitrate, salt concentration, aggregate stability, earthworm numbers, and soil respiration. Components necessary to build a kit include many items commonly available—such as pop bottles, flat-bladed knives, a garden trowel, and plastic wrap. Also necessary to do the tests is some equipment that

is not as readily available, such as hypodermic needles, latex tubing, a soil thermometer, an electrical conductivity meter, filter paper, and an EC calibration standard. The Soil Quality Test Kit Guide can be ordered from the USDA through the Soil Quality Institute's Web page, <<http://soils.usda.gov/sqi/files/KitGuideComplete.pdf>>. The 88-page on-line version of the guide is available in Adobe Acrobat Reader format through the above Web page and may be printed out. A summary of the tests is also available from the Web page. To order a print version, see the Soil Quality Institute reference under **Additional Resources**.

A greatly simplified and quick soil quality assessment is available at the Soil Quality Institute's Web page as well, by clicking on "Getting to Know your Soil," near the bottom of the homepage. This simplified method involves digging a hole and making some observations. Here are a few of the procedures shown at this Web site: Dig a hole 4 to 6 inches below the last tillage depth and observe how hard the digging is. Inspect plant roots to see whether there is a lot of branching and fine root hairs or whether the roots are balled-up. A lack of fine root hairs indicates oxygen deprivation, while sideways growth indicates a hardpan. The process goes on to assess earthworms, soil smell, and aggregation. Another useful, hands-on procedure for assessing pasture soils is discussed in the ATTRA publication *Assessing the Pasture Soil Resource*.

## Early Warning Monitoring for Croplands

A cropland monitoring guide has been published by the Center for Holistic Management (27). The guide contains a set of soil health indicators that are measurable in the field. No fancy equipment is needed to make the assessments described in this monitoring guide. In fact, all the equipment is cheap and locally available for almost any farm. Simple measurements can help determine the health of croplands in terms of the effectiveness of the nutrient cycle and water cycle, and the diversity of some soil organisms. Assessments of living organisms, aggregation, water infiltration, ground cover, and earthworms can be made using this guide. The monitoring guide is easy to read and understand and comes with a field sheet to record observations. It is available for \$12 from the Savory Center for Holistic Management (see [Additional Resources](#)).

## Direct Assessment of Soil Health

Some quick ways to identify a healthy soil include feeling it and smelling it. Grab a handful and take a whiff. Does it have an earthy smell? Is it a loose, crumbly soil with some earthworms present? Dr. Ray Weil, soil scientist at the University of Maryland, describes how he would make a quick evaluation of a soil's health in just five minutes (31).

Look at the surface and see if it is crusted, which tells something about tillage practices used, organic matter, and structure. Push a soil probe down to 12 inches, lift out some soil and feel its texture. If a plow pan were present it would have been felt with the probe. Turn over a shovelful of soil to look for earthworms and smell for actinomycetes, which are microorganisms that help compost and stabilize decaying organic matter. Their activity leaves a fresh earthy smell in the soil.

Two other easy observations are to count the number of soil organisms in a square foot of surface crop residue and to pour a pint of water on the soil and record the time it takes to sink in. Comparisons can be made using these simple observations, along with Ray Weil's evaluation above, to determine how farm practices affect soil quality. Some of the soil quality assessment systems discussed above use these

and other observations and provide record keeping sheets to record your observations.

## A Simple Erosion Demonstration

This simple procedure demonstrates the value of ground cover. Tape a white piece of paper near the end of a three-foot-long stick. Hold the stick in one hand so as to have the paper end within one inch of a bare soil surface (see [Figure 6](#)). Now pour a pint of water onto the bare soil within two to three inches of the white paper and observe the soil accumulation on the white paper. Tape another piece of white paper to the stick and repeat the operation, this time over soil with 100% ground cover, and observe the accumulation of soil on the paper. Compare the two pieces of paper. This simple test shows how effective ground cover can be at preventing soil particles from detaching from the soil surface.

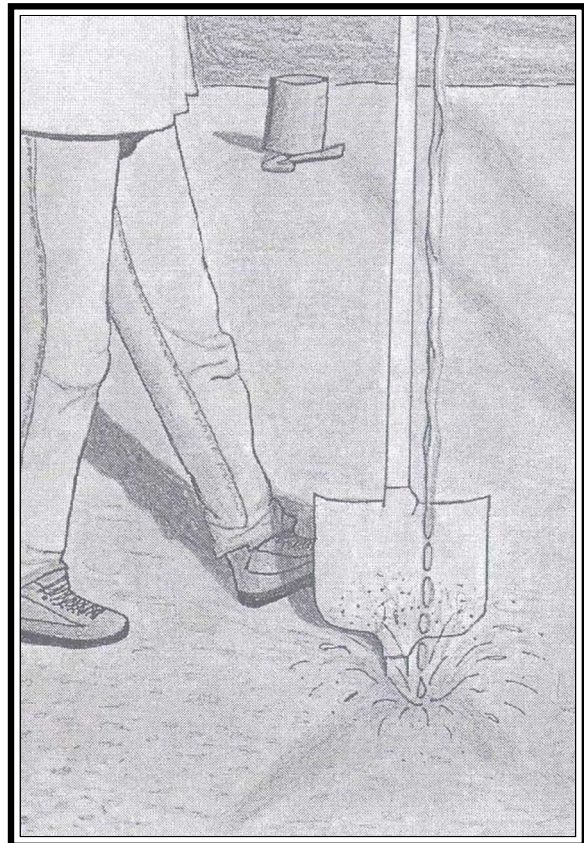

Figure 6. Simple erosion test.  
Drawing from [Cropland monitoring guide](#) (27).

## 2. Use Tools and Techniques to Build Soil

Can a cover crop be worked into your rotation?  
How about a high-residue crop or perennial

sod? Are there economical sources of organic materials or manure in your area? Are there ways to reduce tillage and nitrogen fertilizer? Where feasible, bulky organic amendments may be added to supply both organic matter and plant nutrients. It is particularly useful to account for nutrients when organic fertilizers and amendments are used. Start with a soil test and a nutrient analysis of the material you are applying. Knowing the levels of nutrients needed by the crop guides the amount of amendments applied and can lead to significant reductions in fertilizer cost. The nutrient composition of organic materials can vary, which is all the more reason to determine the amount you have with appropriate testing. In addition to containing the major plant nutrients, organic fertilizers can supply many essential micronutrients. Proper calibration of the spreading equipment is important to ensure accurate application rates.

## Animal Manure

Manure is an excellent soil amendment, providing both organic matter and nutrients. The amount of organic matter and nitrogen in animal manure depends on the feed the animals consumed, type of bedding used (if any), and whether the manure is applied as a solid or liquid. Typical rates for dairy manure would be 10 to 30 tons per acre or 4,000 to 11,000 gallons of liquid for corn. At these rates the crop would get between 50 and 150 pounds of available nitrogen per acre. Additionally, lots of carbon would be added to the soil, resulting in no loss of soil organic matter. Residues from crops grown with this manure application and left on the soil would also contribute organic matter.

However, a common problem with using manure as a nutrient source is that application rates are usually based on the nitrogen needs of the crop. Because some manures have about as much phosphorus as they do nitrogen, this often leads to a buildup of soil phosphorus. A classic example is chicken litter applied to crops that require high nitrogen levels, such as pasture grasses and corn. Broiler litter, for example, contains approximately 50 pounds of nitrogen and phosphorus and about 40 pounds of potassium per ton.

---

**A common problem with using manure as a nutrient source is that application rates are usually based on the nitrogen needs of the crop.**

---

Since an established fescue pasture needs twice as much nitrogen as it does phosphorus, a common fertilizer application would be about 50 pounds of nitrogen and 30 pounds of phosphorus per acre. If a ton of poultry litter were applied to supply the nitrogen needs of the fescue, an over-application of phosphorus would result, because the litter has about the same levels of nitrogen and phosphorus. Several years of litter application to meet nitrogen needs can build up soil phosphorus to excessive levels. One easy answer to this dilemma is to adjust the manure rate to meet the phosphorus needs of the crop and to supply the additional nitrogen with fertilizer or a legume cover crop. On some farms this may mean that more manure is being produced than can be safely used on the farm. In this case, farmers may need to find a way to process and sell (or barter) this excess manure to get it off the farm.

## Compost

Composting farm manure and other organic materials is an excellent way to stabilize their nutrient content. Composted manure is also easier to handle, less bulky, and better smelling than raw manure. A significant portion of raw manure nutrients are in unstable, soluble forms. Such unstable forms are more likely to run off if surface-applied, or to leach if tilled into the soil. Compost is not as good a source of readily available plant nutrients as raw manure. But compost releases its nutrients slowly, thereby minimizing losses. Quality compost contains more humus than its raw components because primary decomposition has occurred during the

composting process. However, it does not contribute as much of the sticky gums and waxes that aggregate soil particles together as does raw manure, because these substances are also released during the primary decomposition

phase. Unlike manure, compost can be used at almost any rate without burning plants. In fact, some greenhouse potting mixes contain 20 to 30% compost. Compost (like manure) should be analyzed by a laboratory to determine the nutrient value of a particular batch and to ensure that it is being used effectively to produce healthy crops and soil, and not excessively so that it contributes to water pollution.

Composting also reduces the bulk of raw organic materials—especially manures, which often have a high moisture content. However, while less bulky and easier to handle, composts can be expensive to buy. On-farm composting cuts costs dramatically, compared with buying compost. For more comprehensive information on composting at the farm or the municipal level, see the ATTRA publication [Farm-Scale Composting Resource List](#).

## Cover Crops and Green Manures

Many types of plants can be grown as cover crops. Some of the more common ones include rye, buckwheat, hairy vetch, crimson clover, subterranean clover, red clover, sweet clover, cowpeas, millet, and forage sorghums. Each of these plants has some advantages over the others and differs in its area of adaptability. Cover crops can maintain or increase soil organic matter if they are allowed to grow long enough to produce high herbage. All too often, people get in a hurry and take out a good cover crop just a week or two before it has reached its full potential. Hairy vetch or crimson clover can yield up to 2.5 tons per acre if allowed to go to 25% bloom stage. A mixture of rye and hairy vetch can produce even more.

In addition to organic matter benefits, legume cover crops provide considerable nitrogen for crops that follow them. Consequently, the nitrogen rate can be reduced following a productive legume cover crop taken out at the correct time. For example, corn grown following two tons of hairy vetch should produce high yields of grain with only half of the normal nitrogen application.

When small grains such as rye are used as cover crops and allowed to reach the flowering stage, additional nitrogen may be required to help offset the nitrogen tie-up caused by the high carbon addition of the rye residue. The same would be true of any high-carbon amendment, such as sawdust or wheat straw. Cover crops also suppress weeds, help break pest cycles, and through their pollen and nectar provide food sources for beneficial insects and honeybees. They can also cycle other soil nutrients, making them available to subsequent crops as the green manure decomposes. For more information on

cover crops, see ATTRA's [Overview of Cover Crops and Green Manures](#). This publication is comprehensive and provides many references to other available information on growing cover crops.

## Humates

Humates and humic acid derivatives are a diverse family of products, generally obtained from various forms of oxidized coal. Coal-derived humus is essentially the same as humus extracts from soil, but there has been a reluctance in some circles to accept it as a worthwhile soil additive. In part, this stems from a belief that only humus derived from recently decayed organic matter is beneficial. It is also true that the production and recycling of organic matter in the soil cannot be replaced by coal-derived humus.

However, while sugars, gums, waxes and similar materials derived from fresh organic-matter decay play a vital role in both soil microbiology and structure, they are not humus. Only a small portion of the organic matter added to the soil will ever be converted to humus. Most will return to the atmosphere as carbon dioxide as it decays.

Some studies have shown positive effects of humates, while other studies have shown no such effects. Generally, the consensus is that they work well in soils with low organic matter. In small amounts they do not produce positive results on soils already high in organic matter; at high rates they may tie up soil nutrients.

There are many humate products on the market. They are not all the same. Humate products should be evaluated in a small test plot for cost effectiveness before using them on a large scale. Salespeople sometimes make exaggerated claims for their products. ATTRA can provide more information on humates upon request.

## Reduced Tillage

While tillage has become common to many production systems, its effects on the soil can be counter-productive. Tillage smoothes the soil surface and destroys natural soil aggregations and earthworm channels. Porosity and water

infiltration decrease following most tillage operations. Plow pans may develop in many situations, particularly if soils are plowed with heavy equipment or when the soil is wet. Tilled soils have much higher erosion rates than soils left covered with crop residue.

Because of all the problems associated with conventional tillage operations, acreage under reduced tillage systems is increasing in America. Any tillage system that leaves in excess of 30% surface residue is considered a “conservation tillage” system by USDA (32). Conservation tillage includes no-till, zero-till, ridge-till, zone-till, and some variations of chisel plowing and disking. These conservation till strategies and techniques allow for establishing crops into the previous crop’s residues, which are purposely left on the soil surface. The principal benefits of conservation tillage are reduced soil erosion and improved water retention in the soil, resulting in more drought resistance. Additional benefits that many conservation tillage systems provide include reduced fuel consumption, flexibility in planting and harvesting, reduced labor requirements, and improved soil tilth. Two of the most common conservation tillage systems are ridge tillage and no-till.

Ridge tillage is a form of conservation tillage that uses specialized planters and cultivators to maintain permanent ridges on which row crops are grown. After harvest, crop residue is left until planting time. To plant the next crop, the planter places the seed in the top of the ridge after pushing residue out of the way and slicing off the surface of the ridge top. Ridges are re-formed during the last cultivation of the crop.

Often, a band of herbicide is applied to the ridge top during planting. With banded herbicide applications, two cultivations are generally used: one to loosen the soil and another to create the ridge later in the season. No cultivation may be necessary if the herbicide is applied by broadcasting rather than banding. Because ridge tillage relies on cultivation to control weeds and reform ridges, this system allows farmers to further reduce their dependence on herbicides, compared with either conventional till or strict no-till systems.

Maintenance of the ridges is key to successful ridge tillage systems. The equipment must accurately reshape the ridge, clean away crop residue, plant in the ridge center, and leave a viable seedbed. Not only does the ridge-tillage cultivator remove weeds, it also builds up the ridge. Harvesting in ridged fields may require tall, narrow dual wheels fitted to the combine. This modification permits the combine to straddle several rows, leaving the ridges undisturbed. Similarly, grain trucks and wagons cannot be driven randomly through the field. Maintenance of the ridge becomes a consideration for each process.

Conventional no-till methods have been criticized for a heavy reliance on chemical herbicides for weed control. Additionally, no-till farming requires careful management and expensive machinery for some applications. In many cases, the spring temperature of untilled soil is lower than that of tilled soil. This lower temperature can slow germination of early-planted corn or delay planting dates. Also, increased insect and rodent pest problems have been reported. On the positive side, no-till methods offer excellent soil erosion prevention and decreased trips across the field. On well-drained soils that warm adequately in the spring, no-till has provided the same or better yields than conventional till.

A recent equipment introduction into the no-till arena is the so-called “no-till cultivator.” These cultivators permit cultivation in heavy residue and provide a non-chemical option to post-emergent herbicide applications. Farmers have the option to band herbicide in the row and use the no-till cultivator to clean the middles as a way to reduce herbicide use. ATTRA can provide a number of resource contacts on cultural methods, equipment, and management for conservation-till cropping systems.

### **Minimize Synthetic Nitrogen Use**

If at all possible, add carbon with nitrogen sources. Animal manure is a good way to add both carbon and nitrogen. Growing legumes as a green manure or rotation crop is another way. When using nitrogen fertilizer, try to do



it at a time when a heavy crop residue is going onto the soil, too. For example, a rotation of corn, beans, and wheat would do well with nitrogen added after the corn residue was rolled down or lightly tilled in. Spring-planted soybeans would require no nitrogen. A small amount of nitrogen could be applied in the fall for the wheat. Following the wheat crop, a legume winter-annual cover crop could be planted. In the spring, when the cover crop is taken out, nitrogen rates for the corn would be reduced to account for the nitrogen in the legume. Avoid continual hay crops accompanied by high nitrogen fertilization. The continual removal of hay accompanied by high nitrogen speeds the decomposition of soil organic matter. Heavy fertilization of silage crops, where all the crop residue is removed (especially when accompanied by tillage), speeds soil decline and organic matter depletion.

### 3. Continue to Monitor for Indicators of Success or Failure

As you experiment with new practices and amendments, continue to monitor the soil for changes using some of the tools discussed above in **Assess Soil Health and Biological Activity**. Several of these monitoring guides have sheets you can use in the field to record data and use for future comparison after changes are made to the farming practices. Review the principles of sustainable soil management and find ways to apply them in your operation. If the thought of pulling everything together seems overwhelming, start with only one or two new practices and build on them. Seek additional motivation by reading the next section on people who have successfully built their soils.



## PART III. EXAMPLES OF SUCCESSFUL SOIL BUILDERS (FARMER PROFILES)

### Steve Groff

Steve and his family produce vegetables, alfalfa, and grain crops on 175 acres in Lancaster County, Pennsylvania. When Steve took over operation of the family farm 15 years ago, his number one concern was eliminating soil erosion. Consequently, he began using cover crops extensively in his fields. In order to transform his green cover crop into no-till mulch, Steve

uses a 10-foot Buffalo rolling stalk chopper. Under the hitch-mounted frame, the stalk chopper has two sets of rollers running in tandem. These rollers can be adjusted for light or aggressive action and set for continuous coverage. Steve says the machine can be run up to eight miles an hour and does a good job of killing the cover crop and pushing it right down on the soil. It can also be used to flatten down other

crop residues after harvest. Steve improved his chopper by adding independent linkages and springs to each roller. This modification makes each unit more flexible and allows continuous use over uneven terrain. Other farmers report similar results using a disk harrow with the gangs set to run straight or at a slight angle. Following his cover crop chopping, Steve transplants vegetable seedlings into the killed mulch; sweet corn and snap beans are direct-seeded. Since conversion to a cover crop mulch system, his soils are protected from erosion and have become much mellower. For more information on his system, order Steve's videos listed under **Additional Resources**, or visit his Web page at <<http://www.cedarmeadowfarm.com/about.html>>. At Steve's Web site you can see photos of his cover crop roller and no-till transplanter in action, as well as test-plot results comparing flail mowing, rolling, and herbicide killing of cover crops.

### **Bob Willett**

Bob started no-tilling 20 years ago on his corn and soybean farm in Pride, Kentucky. He not only reduced his machinery costs by switching to no-till but also made gains in conserving topsoil. His goal is to develop a healthy level of humus in the top two inches, which keeps the seed zone loose. He has stopped the sidewall compaction in the seed slot that still plagues his neighbors during wet springs. He attributes this improvement to the increase in humus and organic matter. His soil surface layer is crumbly and doesn't smear when the disk openers pass through. Bob proclaims that earthworms take the place of tillage by incorporating residue and converting it to humus. Worms help aerate his soil and improve internal drainage, which contributes to good rooting for his crops (33).

### **David Iles**

On the Iles's North Carolina dairy farm the soil has actually changed from red to a dark, almost black color since conversion to no-till in 1970. David first learned about no-till from his college professor at North Carolina State University in 1964. Before he switched to no-till, David's corn silage yielded between 12 and 15 tons per acre in years with adequate rainfall and 4 to 5 tons in dry years—indicating that mois-

ture was his major limiting factor (34). David realized that his water runoff losses and soil erosion were a direct result of tillage. Addressing the root cause of the problem, he switched to no-till and began to spread manure on 1/3 of his land annually. Since these changes, soil water is no longer limiting. With adequate rainfall he makes nearly 20 tons of silage now. David says his land is vastly more productive, with increased cation exchange capacity and increased phosphorus levels due to the humus present in his soil. Though his soil pH ranges in the 5.6 to 5.8 level, he applies no lime. His fields are more productive now than when he applied lime in the '70s and more productive than those of his neighbors who currently use lime and fertilizer.

David laments that this country has lost half of its topsoil in less than 100 years (34). North Carolina State agronomist Bobby Brock agrees and says that for the first time in history we have the opportunity to produce food and build soil at the same time. David reasons that no-till is the way to improve the soil structure, increase tilth, and increase productivity while still practicing intensive agriculture. He realizes that organic matter is the engine that drives his system and provides food for earthworms and microorganisms. David built his soil by fallowing out 20 to 25 acres of his 380-acre farm each year. On these fallow acres he spreads manure and then sows crops that are not harvested but grown just for their organic matter. Even weeds are not clipped but left for their organic matter. David loves his earthworms and says they are the best employees he has. "They work all the time and eat dirt for a living" (34).

His best field is one he cleared himself in the '70s. In spite of traditional native pHs in the high 4s in his area, he did not lime this new ground but instead just planted rye on it. He had a fine rye crop that year, so he applied manure liberally and planted rye a second time. His second rye crop was excellent as well and was followed by corn the third year. That field yielded the most corn on the entire farm. This field has been in continuous corn since 1981 and has never been fertilized with conventional products or tilled (34). This field has a pH of

6.1 at a 6-inch depth, an exchange capacity of 8, and an 80% base saturation. David believes this field's productivity is high because it has never been harmed by tillage.

## References

- 1) Cramer, Craig. 1994. Test your soils' health—first in a series. *The New Farm*. January. p. 17-21.
- 2) Pimentel, D., et al. 1995. Environmental and economic costs of soil erosion and conservation benefits. *Science*. Vol. 267, No. 24. p. 1117-1122.
- 3) U.S. Department of Agriculture. 1998. Soil Biodiversity. Soil Quality Information Sheet, Soil Quality Resource Concerns. January. 2 p.
- 4) Edwards, Clive A., and P.J. Bohlen. 1996. *Biology and Ecology of Earthworms*. Chapman and Hall, New York. 426 p.
- 5) Edwards, Clive A., and Ian Burrows. 1988. The potential of earthworm composts as plant growth media. p. 211-219. *In: Earthworms in Waste and Environmental Management*. C.A. Edwards and E.F. Neuhauser (eds.). SPB Academic Publishing, The Hague, The Netherlands.
- 6) Graff, O. 1971. Stikstoff, phosphor und kalium in der regenwormlösung auf der wiesenversuchsfleche des sollingprojektes. *Annales de Zoologie: Ecologie Animale*. Special Publication 4. p. 503-512.
- 7) Anon. 1997. Product choices help add to worm counts. *Farm Industry News*. February. p. 64
- 8) Kladvko, Eileen J. No date. Earthworms and crop management. *Agronomy Guide*, AY-279. Purdue University Extension Service, West Lafayette, IN. 5 p.
- 9) Soil Foodweb. 1228 NE 2<sup>nd</sup> Street. Corvallis, OR.
- 10) Bollen, Walter B. 1959. *Microorganisms and Soil Fertility*. Oregon State College. Oregon State Monographs, Studies in Bacteriology, No. 1. 22 p.
- 11) Jackson, William R. 1993. *Organic Soil Conditioning*. Jackson Research Center, Evergreen, CO. 957 p.
- 12) Comis, Don. 1997. Glomalin—soil's superglue. *Agricultural Research*. USDA-ARS. October. p. 22.
- 13) Boyle, M., W.T. Frankenberger, Jr., and L.H. Stolzy. 1989. The influence of organic matter on soil aggregation and water infiltration. *Journal of Production Agriculture*. Vol. 2. p. 209-299.
- 14) Pipel, N. 1971. Crumb formation. *Endeavor*. Vol. 30. p. 77-81.
- 15) Land Stewardship Project. 1998. *The Monitoring Toolbox*. White Bear Lake, MN. Page number unknown.
- 16) Allison, F.E. 1968. Soil aggregation—some facts and fallacies as seen by a microbiologist. *Soil Science*. Vol. 106, No. 2. p. 136-143.
- 17) Reicosky, D.C., and M.J. Lindstrom. 1995. Impact of fall tillage on short-term carbon dioxide flux. p. 177-187. *In: R.Lal, J. Kimble, E. Levine, and B.A. Stewards (eds.). Soils and Global Change*. Lewis Publisher, Chelsea, MI.
- 18) Nation, Allan. 1999. Allan's Observations. *Stockman Grass Farmer*. January. p. 12-14.
- 19) Sanderson, M.A., et al. 1999. Switchgrass cultivars and germplasm for biomass feedstock production in Texas. *Bioresource Technology*. Vol. 67, No 3. p. 209-219.
- 20) Sachs, Paul D. 1999. *Edaphos: Dynamics of a Natural Soil System*, 2<sup>nd</sup> edition. The Edaphic Press. Newbury, VT. 197 p.

- 21) Kinsey's Agricultural Services, 297 County Highway 357, Charleston, MO 63834 573-683-3880
- 22) Tisdale, S.L., W.L. Nelson, and J.D. Beaton. 1985. *Soil Fertility and Fertilizers*, 4th Edition. Macmillian Publishing Company, New York. 754 p.
- 23) Francis, Charles A., Cornelia B. Flora, and Larry D. King. 1990. *Sustainable Agriculture in Temperate Zones*. John Wiley and Sons, Inc., New York. 487 p.
- 24) Parker, M.B., G.J. Gasho, and T.P. Gaines. 1983. Chloride toxicity of soybeans grown on Atlantic coast flatwoods soils. *Agronomy Journal*. Vol. 75. p. 439-443.
- 25) Schertz. 1985. Field evaluation of the effect of soil erosion on crop productivity. p. 9-17. *In: Erosion and Soil Productivity. Proceedings of the National Symposium on Erosion and Soil Productivity*. American Society of Agricultural Engineers. December 10-11, 1984. New Orleans, LA. ASAE Publication 8-85.
- 26) Troeh, F.R., J.A Hobbs, and R.L. Donahue. 1991. *Soil and Water Conservation*. Prentice Hall, Englewood Cliffs, NJ.
- 27) Sullivan, Preston G. 1998. *Early Warning Monitoring Guide for Croplands*. Center for Holistic Management, Albuquerque, NM. 22 p.
- 28) Gantzer, C.J., S.H. Anderson, A.L. Thompson, and J.R. Brown. 1991. Evaluation of soil loss after 100 years of soil and crop management. *Agronomy Journal*. Vol. 83. p. 74-77.
- 29) Shiflet, T.N., and G.M. Darby. 1985. Table 3.4: Effect of row and sod crops on runoff and erosion [from G.M. Browning, 1973]. p. 26. *In: M.E. Heath, R.F. Barnes, and D.S. Metcalfe (eds.). Forages: The Science of Grassland Agriculture*, 4<sup>th</sup> ed. Iowa State University Press, Ames, IA.
- 30) Jackson, Wes. 1980. *New Roots for Agriculture*, 1st edition. Friends of the Earth, San Francisco, CA. 150 p.
- 31) Bowman, Greg. 1994. Why soil health matters. *The New Farm*. January. p. 10-16.
- 32) Magdoff, Fred. 1992. *Building Soils for Better Crops*, 1st ed. University of Nebraska Press, Lincoln, NE. 176 p.
- 33) Sickman, Tim. 1998. Building soil with residue farming. *Tennessee Farmer*. August. p. 32, 34.
- 34) Dirnburger, J.M., and John M. Larose. 1997. No-till saves dairy farm by healing the harm that tillage has done. *National Conservation Tillage Digest*. Summer. p. 5-8.

## Additional Resources

### Videos

**No-till Vegetables.** By Steve Groff. 1997.

*This video leads you from selection of the proper cover crop mix to plant into, through how to control cover crops with little or no herbicide, as shown on Steve Groff's Pennsylvania farm. You will see mechanical cover-crop-kill and vegetables being planted right into this mulch using a no-till transplanter. You'll also hear comments from leading researchers in the no-till vegetable area. Order this video for \$21.95 + \$3.00 shipping from:*

Cedar Meadow Farm  
679 Hilldale Road  
Holtwood, PA 17532  
717-284-5152

### Books and Periodicals

**The Farmer's Earthworm Handbook: Managing Your Underground Money Makers.** 1995. By David T. Ernst. Lessiter Publications, Brookfield, WI. 112 p.

To order, send \$15.95 + \$4.00 shipping and handling to:

Lessiter Publications  
245 Regency Court  
Brookfield, WI 53045  
262-782-4480  
800-645-8455

**The Soul of Soil: A Guide to Ecological Soil Management**, 4th edition. 1995. By Grace Gershuny and Joe Smillie. AgAccess, Davis, CA. 158 p.

To order, send \$8.50 + \$4.00 shipping and handling to:

Fertile Ground Books  
3912 Vale Ave. Oakland, CA 94619  
530-297-7879  
[books@agribooks.com](mailto:books@agribooks.com)  
<http://www.agribooks.com/>

**Neal Kinsey's Hands-On Agronomy**. 1993. By Neil Kinsey. Acres, USA. Metairie, LA. 340 p.

To order, send \$24.00 + \$3.00 shipping and handling to:

ACRES USA  
P.O. Box 91299  
Austin, TX 78709-1299  
800-355-5313 (toll-free)  
512-892-4400

**Building Soils for Better Crops**, 2nd edition. 2000. By Fred Magdoff and Harold van Es. University of Nebraska Press, Lincoln, NE. 240 p.

To order, send \$19.95 + \$3.95 shipping to:

Sustainable Agriculture Publications  
Hills Building, Room 10,  
University of Vermont  
Burlington, VT 05405-0082  
802-656-0484;  
[sanpubs@uvm.edu](mailto:sanpubs@uvm.edu).

**Edaphos: Dynamics of a Natural Soil System**, 2nd edition. 1999. By Paul D Sachs. The Edaphic Press, Newbury, VT. 197 p.

To order, send \$14.95 + \$1.50 shipping and handling to:

North Country Organics  
P.O. Box 372  
Bradford, VT 05033  
802-222-4277

**Soil Quality Test Kit Guide**. 1998. USDA. Soil Quality Institute. 82 p.

*This publication has detailed, step-by-step instructions with color photographs on how to assess soil quality, soil respiration, soil water infiltration, bulk density, electrical conductivity, soil pH, soil nitrate, soil aggregate stability, slaking, and earthworms. It also covers soil physical observations and estimations and water quality tests, and includes background information on the tests and appendices. To order this free test kit publication, paid for by your federal tax dollars, contact:*

Dr. Charles Kome, Soil Scientist  
Soil Quality National Technology  
Development Team  
USDA-NRCS ENTSC  
200 E. Northwood St., Ste. 410  
Greensboro, NC 27401  
phone: (336) 370-3363  
[charles.kome@gnb.usda.gov](mailto:charles.kome@gnb.usda.gov)

**Early Warning Monitoring for Croplands**. 1998. By Preston G. Sullivan. Center for Holistic Management, Albuquerque, NM. 22 p.

To order this guide, send \$13.00 ppd. to:

Savory Center for Holistic Management  
1010 Tijeras, N.W.  
Albuquerque, NM 87102

505-842-5252

<http://www.holisticmanagement.org/>

**LaMotte Soil Handbook.** 1994. Lamotte Company. Chestertown, MD. 81 p.

*Covers soil basics, nutrients, pH, acidity and alkalinity, and principles of the LaMotte soil testing system. Has relative nutrient and pH requirements for common crops and plants. To order this handbook ask for reference # 1504 and send \$4.85 to:*

LaMotte Company  
P.O. Box 329  
Chestertown, MD 21620  
410-778-3100  
800-344-3100 (toll-free)  
410-778-6394 FAX  
[ese@lamotte.com](mailto:ese@lamotte.com)  
<http://www.lamotte.com/>

**How to Get Started in Biological Farming.** No date. Gary F. Zimmer. 11 p.

*To order this publication, send \$3 + \$1 shipping to:*

Midwestern Bio-Ag  
Highway ID, Box 160  
Blue Mounds, WI 53517  
608-437-4994

**Glomalinal, a Manageable Soil Glue.** 1999. Sara Wright. 1-page brochure.

*To order this free publication contact:*

Sara Wright  
USDA-ARS-SMSL  
Bldg. 001, Room 140, BARC-W  
10300 Baltimore Avenue  
Beltsville, MD 20705-2350  
301-504-8156  
<http://www.ba.ars.usda.gov/sasl/research/glomalinal/brochure.pdf>

## Soil Web Sites

### Life in the Soil

<http://www.saburchill.com/chapters/chap0059.html>

*This excellent Web site includes brief overviews of many subjects, including nutrient transformation, biological degradation, soil structure, crop rotation, tillage, soil testing for microbes, and organic matter turnover. Color photos of many soil critters with short descriptions appear on the main Web page. Other drawings and black and white photos of soil microbes and their effects on soil are on other pages at this site.*

### The Pedosphere and its Dynamics: A Systems Approach to Soil Science

University of Alberta's Soil Science

<http://www.pedosphere.com/main.html>

*A complete on-line soils textbook covering what soil is, ecological functions of soil, soil texture, structure and color, soil formation, Canadian soil classification system, mineralogy, soil reaction, soil water, soil air, soil ecology, soil organic matter, and soil survey. To view this textbook click on the textbook icon at the homepage. Much more information is available from the homepage, including educational resources, tutorials, workshops, publications, etc.*

### Soil Biological Communities

Idaho state office of the Bureau of Land Management

<http://www.blm.gov/nstc/soil/>

*For drier areas, the Idaho state office of the Bureau of Land Management has an interesting Web site on soil biological communities that covers biological crusts, fungi, bacteria, protozoa, nematodes, arthropods, the soil food web, and mammals. The site has many photographs that bring to life many of the soil inhabitants.*

### **Soil Foodweb Inc.**

[http://www.soilfoodweb.com/sfi\\_html/index.html](http://www.soilfoodweb.com/sfi_html/index.html)

*S. F. I. is the soil microbial analysis lab founded by Dr. Elaine Ingham. In addition to general background on the importance of the soil foodweb, the Web site contains information on commercial products and agricultural practices that support different microbial communities. This site has much interesting information, including how to have soil tested for different soil organisms.*

### **New Generation Cropping Systems**

<http://www.cedarmeadowfarm.com/about.html>

*This is the Web site describing Steve Groff's innovative Cedar Meadow Farm in Lancaster County, Pennsylvania. Cedar Meadow is a model sustainable agriculture farm. Steve and his family grow corn, alfalfa, tomatoes, pumpkins, soybeans, small grains, and other vegetables. They use no-till and mechanically killed cover crop mulches in a tight crop rotation. At this Web page you will see action shots of no-till planting into mechanically killed cover crops and find ordering information for Steve Groff's video mentioned above.*

### **Soil Quality Information Sheets**

Soil Quality Institute, Natural Resources Conservation Service

[http://soils.usda.gov/sqi/soil\\_quality/what\\_is/sqiinfo.html](http://soils.usda.gov/sqi/soil_quality/what_is/sqiinfo.html)

*Produced by the Soil Quality Institute, Natural Resources Conservation Service, this Web site features on-line information sheets on soil quality topics. Among the topics are erosion, sedimentation, deposition, compaction, salinization, soil biodiversity, available water capacity, pesticides, indicators for soil quality evaluation, organic matter, soil crusts, aggregate stability infiltration, and soil pH.*

**By Preston Sullivan**

**NCAT Agriculture Specialist**

**©2004 NCAT**

**May 2004**

**IP027**

**Slot 133**

**Version 062104**

The electronic version of **Sustainable Soil Management** is located at:

HTML

<http://www.attra.ncat.org/attra-pub/soilmgmt.html>

PDF

<http://www.attra.ncat.org/attra-pub/PDF/soilmgmt.pdf>

By Preston Sullivan  
 NCAT Agriculture  
 Specialist  
 Published 2001  
 Updated April 2010  
 By Hannah Sharp  
 NCAT Intern  
 © NCAT

## Contents

Making fertility assessments .....	1
Assessing soil biological activity and health .....	2
When to make these assessments .....	2
Equipment needed .....	3
Locating sample sites ...	3
Points of assessment ....	3
1) Living organisms ....	3
2) Earthworms .....	3
3) Soil smell .....	4
4) Aggregation .....	4
5) Water infiltration ....	4
6) Soil compaction .....	4
Conclusion .....	5
References .....	6
Further resources .....	6
Assessment sheet .....	7

ATTRA—National Sustainable Agriculture Information Service ([www.attra.ncat.org](http://www.attra.ncat.org)) is managed by the National Center for Appropriate Technology (NCAT) and is funded under a grant from the United States Department of Agriculture's Rural Business-Cooperative Service. Visit the NCAT website ([www.ncat.org/sarc\\_current.php](http://www.ncat.org/sarc_current.php)) for more information on our sustainable agriculture projects.



This technical note provides methods to determine biological activity of pasture soils and practical tips on improving the usefulness of typical soil and plant samples. The soil biology sampling methods are easy to learn and utilize commonly available tools found around any farm. Once these biological assessments are made, more insight into the many benefits of nutrient cycling becomes apparent. Methods for strategically using soil and plant samples are also covered.

## Introduction

### Making fertility assessments

A typical soil analysis will provide a guide to the current plant nutrient levels in a pasture soil. For an analysis to be accurate, good sampling procedure must be followed. Before sampling a pasture soil:

1. Visit the county Cooperative Extension Office and get their guide on soil sampling procedure.
2. Look across the landscape and locate all hotspots. Hotspots are areas of excessive or unusual nutrient concentration, such as soils around feed bunks, hay feeding areas, shade trees, watering sites, loafing areas and wet spots.
3. Sample these hotspots separately, or avoid them during your sampling.
4. Sample according to apparent patterns such as slope and previous fertilization. When field areas appear dissimilar, sample them separately. Nutrients tend to flow downhill in pastures, meaning that top slopes will tend to have lower nutrient levels and the down slope will tend to have higher levels. Mixing soil samples from all over the pasture will mask these differences and lead to wasted fertilizer dollars. When it comes time to buy fertilizer, you may only need to fertilize the



Photo by Susan Tallman, NCAT.

ridge tops and will be glad you sampled top, side and end slopes separately.

5. Make sure that sampling depth matches the depth that the soil test report will be based on. Many agronomists advise taking pasture samples at 3 or 4 inches deep because most of the grass roots are in the top 4 inches. The prescribed depth should be in the soil sampling procedure from your Cooperative Extension Office. If you do take a sample at a depth other than the one the lab specifies, make note of it on your sample sheet so the lab can adjust accordingly.
6. Prepare the sample for shipping according to the lab's recommendations.

Producers generally have the choice of using a private laboratory or the state university lab to do their soil analysis. Commercial labs cost more but generally have a quicker turnaround time and a more complete soil test report than university labs. Though hotly contested by some researchers, soil analysis featuring the base saturation percentages



provides useful information for making fertilizer choices. If you would like to get a second opinion, it may be worthwhile to hire a consultant to help you with the sampling and the fertilizer recommendations.

To back up your fertilization program you may want to take forage samples to see what effect the fertilizer had. You can also strategically utilize soil and forage tissue sampling by making comparisons between poor growth areas and good growth areas, or before-and-after comparisons. The three tables below show some hypothetical examples of strategic soil and plant tissue sampling.

Forage analysis can be used to judge the success of a fertilization program by identifying any remaining nutrient deficits. For example, the before-and-after forage analysis shown in **Table 1** shows that the applied fertilizer met all crop needs for major and secondary nutrients. In addition, soil and forage analysis taken from adjacent poor and productive field areas can be used to better identify nutrient imbalances. This is illustrated in **Tables 2 and 3**. Visit your county extension agent or a private consultant to learn effective methods for taking a forage sample.

### Related ATTRA publications

Nutrient Cycling in Pastures

A Brief Overview of Nutrient Cycling in Pastures

Sustainable Soil Management

**Table 1. Forage tissue analysis before and after fertilization**

Nutrient	Before fert.	After fert.
Nitrogen	low	OK
Phosphorus	OK	OK
Potassium	low	OK
Calcium	OK	OK
Magnesium	OK	OK
Sulfur	low	OK

**Table 2. Forage tissue analysis between a poor area and a good area**

Nutrient	Poor area	Good area
Nitrogen	low	OK
Phosphorus	OK	OK
Potassium	low	OK
Calcium	OK	OK
Magnesium	OK	OK
Sulfur	low	OK

**Table 3. Soil test analysis between a poor area and good area of a pasture**

Nutrient	Poor area	Good area
Nitrogen	—	—
Phosphorus	OK	OK
Potassium	low	OK
Calcium	OK	OK
Magnesium	OK	OK
Sulfur	OK	OK

## Assessing soil biological activity and health

While nutrient status is essential to soil health and vitality, biological activity and soil structure should be appraised to get a more complete picture. The biological soil component creates and maintains many desirable soil conditions. Many biological parameters are quite costly to measure and require hours of laboratory time. Others can be quite inexpensive and convenient. The following assessment procedures can be performed in an hour or so using inexpensive, locally available materials (Holistic Management International, 2007). These procedures are derived from *Holistic Management Biological Monitoring Manual* available from Holistic Management International. For a more complete cropland assessment, order this publication. Ordering information is listed in the **Further resources** section.

### When to make these assessments

Choose a time of year when soil biological activity is high, usually in late spring and mid-fall. Select a day when the soil is moist but not wet, after all excess water has drained away. Generally, the soil is right for this assessment when you cannot roll the soil into a ball and it crumbles easily in your hand.

Avoid taking samples:

- From wet soils. When the soil sticks to your shoes, it is too wet.
- During drought periods or times of excessive heat.

- From cold soils.
- Within a month following tillage, fertilization or liming.

## Equipment needed

- Pencil
- Assessment sheet
- Clipboard to hold the paper
- Shovel
- Can or jar capable of holding 16 fluid ounces (1 pint) but no more
- Small round bottle capable of holding ½ cup of water
- Bucket with 2 gallons of water for each assessment sheet to be filled out
- Watch with a second hand or a stopwatch
- Tape measure
- Hand grass clippers
- Homemade soil penetrometer, described below
- A wire ring that measures 1 foot across, made of wire or flexible pipe

*Note: The length of wire required to make a circle with a 1-foot diameter is approximately 39 inches, depending on the thickness of the wire. Remember to allow some extra length to attach the two ends and make the ring. Measure the diameter of the wire ring when the ends are attached to make sure it is 1 foot across.*

## Locating sample sites

An individual assessment sheet should be used for each pasture. If a pasture is highly variable, assess each distinct area separately. In each pasture unit, three sampling sites should be selected. Use field maps, compasses, landmarks or global positioning systems to locate representative sample sites that can be relocated year after year. These sites become permanent locations for assessing change over time. Each field site can be marked on a map to aid relocation. At each sampling site, choose two points to take the actual assessment.

Begin by selecting the first point for evaluation at the sampling site and lay the 1-foot diameter ring on the ground. The following assessments are most conveniently done by completing all six at the first point before moving on to the second point.

## Points of assessment

### 1) Living organisms

Clip all the standing vegetation within the wire circle down to the ground and remove it. Pull back the soil surface litter and look for signs of living organisms other than plants. A small hand rake may help in turning the surface litter. Count the number of different kinds of living critters, such as beetles, ants, millipedes, centipedes, snails and more, on the soil surface within the ring. Record the numbers on the assessment sheet.

It is advisable to start turning the surface litter from the outside of the ring toward the center. This forces mobile critters to the center where they will be seen by the observer. If you start at the center and work toward the ring, the critters have a chance to escape outside the ring undetected. With this assessment the number of species, or diversity, is more important than the number of individuals.

A higher number of different types of organisms indicates more biodiversity. The more biodiversity, the better the first stage of decomposition will proceed.

### 2) Earthworms

While still at the circle, count the number of wormholes inside the ring. The surface holes are the vertical burrows of nightcrawler worms. After counting the wormholes, insert the shovel to its maximum depth and turn over the shovelful of soil. Break the soil apart with your hands and count the number of earthworms present. The smaller worms found with the shovel will most likely be the surface-dweller earthworms that do not burrow vertically.

Record the numbers on the assessment sheet. Also note how easy or difficult it was to shovel the soil. Turning a shovelful of

**I**f a pasture is highly variable, assess each distinct area separately. In each pasture unit, three sampling sites should be selected.

soil also correlates well with tillage and ease of tillage. The more earthworms found in this process, the better. Earthworm burrows enhance water infiltration and soil aeration. Earthworm digestion of soil and organic matter cycles nutrients. Worms are a general indicator of soil health. Earthworms may not be present in croplands recently converted to pasture. They should slowly return over several years from adjacent field margins as soil health improves.

### 3) Soil smell

While still at the hole dug for worm counts, grab a handful of topsoil and take a whiff. Record the smell on the assessment sheet as follows:

0.0 = putrid/chemical/sour

0.2 = no smell

0.4 = fresh/earthy/sweet

### 4) Aggregation

Select a soil aggregate, or crumb, from a handful of topsoil. Make sure the aggregate is not a rock or pebble. Put the aggregate in the small round bottle of water or the 1-pint container. Allow it to stand for one minute, using the stopwatch to keep time. Observe if the aggregate is breaking apart or staying intact. If it stays intact after one minute, gently swirl the bottle several times and observe again. If it is still intact, swirl the bottle vigorously and observe the aggregate again for intactness. Record the following scores:

1 = aggregate broke apart within one minute in standing water

2 = aggregate remained intact in standing water but broke apart after gentle swirling

3 = aggregate remained intact after gentle swirling

4 = aggregate remained intact after vigorous swirling

After vigorous swirling, remove the aggregate and smash it between your fingers to make sure it was not a pebble. If it was a pebble, select another aggregate and do the test again. Healthy soils have very stable aggregates,

indicated here by a high score. Unstable aggregates break apart easily and the individual soil particles can be easily eroded by runoff water. Higher scores are generally more common under perennial sod. Lower scores are generally more common on soils with annual tillage operations and clean cultivation.

Move away from the wire circle to a fresh area. Clip a small area of grass to ground level if necessary to see the soil surface clearly. Fill a 1-pint container with water. Holding the container as close to the soil surface as possible, gently pour the water on the soil. Try to pour all the water out within five seconds, the idea being to avoid disrupting the soil surface with the water flow, but pouring fast enough to determine how quickly the water soaks into the ground. Using the stopwatch, start timing once all the water has been poured out. Stop timing when the last of the water just finishes soaking into the ground. This is the infiltration time to be recorded on the assessment sheet.

Next, measure the wet spot across its widest point with the tape measure and record the length on the assessment sheet. Pouring on a slope will influence the rate of runoff. If you are comparing two cropping practices on sloping ground, make sure the slope is the same under both practices since slope will influence the runoff rate.

### 5) Water infiltration

The faster water enters the soil, the less likely it is to run off overland and cause erosion. A well-aggregated soil will take in water rapidly, as will a soil with high numbers of vertical wormholes. Texture plays a significant role in water infiltration. Sandy soils will take in water more quickly than silty-loam soils, and clay soils will take in water quite slowly. Finally, since soil moisture at the time will influence this assessment, don't put too much confidence in an infiltration comparison between two fields if one is irrigated and the other is dry.

### 6) Soil compaction

Assessing soil compaction requires making a simple tool beforehand. A soil penetrometer

**A** well-aggregated soil will take in water rapidly, as will a soil with high numbers of vertical wormholes.

can be constructed from a 1/4-inch rod sharpened on the end as seen in **Figure 1** below. Start with a rod that is 3 feet long. Use a file to make 1-inch marks from the pointed end, as shown in the drawing.

Push your homemade penetrometer into the soil as deep as you can with modest effort. Record the inches of penetration up to a maximum of 12 inches. Do not record any penetration depths beyond 12 inches, as we are not testing for deep penetration. Avoid putting all your weight into the pushing or stomping on the penetrometer to make it go deeper. Record the penetrometer depth on the assessment sheet. If you hit a rock or tree root, try again. For comparison, probe an undisturbed natural area nearby with your penetrometer. As a secondary test, you may wish to probe deeper with a longer penetrometer to locate any deeper hard pans to note on the comment section of the assessment sheet.

The deeper the probe easily penetrates the soil, the better. Ease of soil penetration with the penetrometer correlates to deep root development, ease of downward water flow, or no hardpan, and tillage ease. A probe that won't penetrate the soil indicates

compaction of the surface layer, which restricts downward water movement (Holistic Management International, 2007).

## Conclusion

Performing the soil organism assessment described will enhance observational skills, which is always beneficial. Some other useful observations include plant vigor, plant coloration, drought tolerance and the rate at which livestock manure is dispersed and decayed. Healthy soil conditions are largely created by the helpful soil organisms, which are beneficial with a little management to meet their needs.

Don't be discouraged if the pasture assessment numbers come up lower than expected the first time. Rather, let the results be an incentive for continued commitment to soil improvement. Pursue progress rather than perfection. An assessment provides a starting point from which to build toward the future. Set your sights high. Discard the idea that soils require hundreds of years to build up. Soils can begin to improve just a few months after appropriate decisions are made.

**Figure 1: Homemade soil penetrometer**

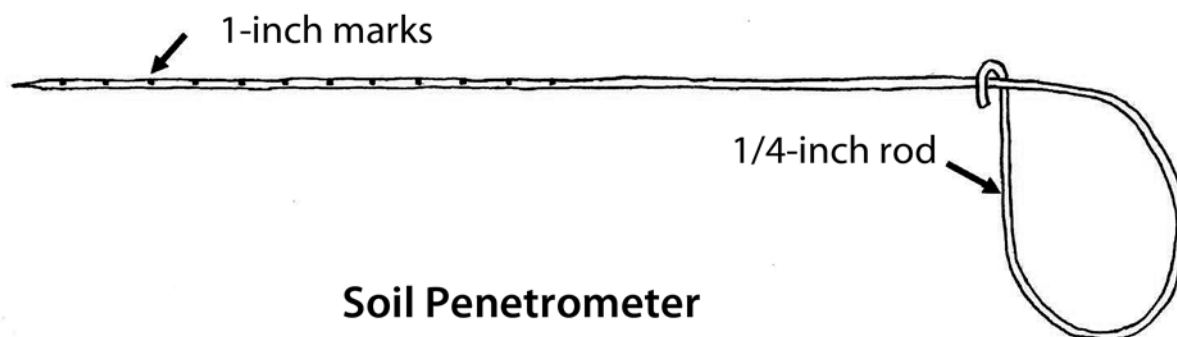

## References

---

Holistic Management International. Holistic Management Biological Monitoring Manual. 2007. 59 p. <http://holisticmanagement.org/store//page4.html>

### Further resources

Anon. 1999. Soil Quality Test Kit Guide. Soil Quality Institute. Natural Resources Conservation Service. USDA. Accessed May 2009. [http://soils.usda.gov/sqi/assessment/files/test\\_kit\\_complete.pdf](http://soils.usda.gov/sqi/assessment/files/test_kit_complete.pdf)

Anon. 2003. Pastureland Soil Quality – Indicators for Assessment and Monitoring. Natural Resources Conservation Service. USDA. Accessed May 2009. <http://soils.usda.gov/sqi/management/files/PSQIS2.pdf>

Evanylo, Greg and Robert McGuinn. 2000. Agricultural Management Practices And Soil Quality. Natural Resources and Environmental Management. Virginia Cooperative Extension. Virginia Tech. Accessed May 2009. [www.ext.vt.edu/pubs/compost/452-400/452-400.html](http://www.ext.vt.edu/pubs/compost/452-400/452-400.html)

Fawcett, Richard. No date. An Introduction to Nutrient Management. Conservation Technology Information Center. Accessed May 2009. [http://ctic.org/media/pdf/nutrient\\_mgmt\\_primer\\_1.pdf](http://ctic.org/media/pdf/nutrient_mgmt_primer_1.pdf)

Nation, Allan. 1995. Quality Pasture. Mississippi Valley Publishing, Corp., Jackson, MS. 285 p.

*To order this publication, visit the Stockman Grass Farmer online store at [www.stockmangrassfarmer.net/cgi-bin/page.cgi?id=364.html](http://www.stockmangrassfarmer.net/cgi-bin/page.cgi?id=364.html) or contact Stockman Grass Farmer, PO Box 2300, Ridgeland, MS 39158-9911, 1-800-748-9808, (601) 853-1861, (601) 853-8087 FAX, [sgf@stockmangrassfarmer.com](mailto:sgf@stockmangrassfarmer.com)*

Tugel, A.J., A.M. Lewandowski and D. Happe-vonArb, eds. 2000. Soil Biology Primer. Ankeny, IA: Soil and Water Conservation Society. 48 p.

*To order this publication, visit the Soil and Water Conservation Society online store at [http://store.swcs.org/index.cfm?fuseaction=c\\_Products.viewProduct&catID=574&productID=5154](http://store.swcs.org/index.cfm?fuseaction=c_Products.viewProduct&catID=574&productID=5154)*

Holistic Management International. Holistic Management Biological Monitoring Manual. 2007. 59 p.

*To order this publication, visit the HMI online store at <http://holisticmanagement.org/store//page4.html> or contact Holistic Management International (HMI), 1010 Tijeras, NW, Albuquerque, NM 87102, (505) 842-5252, (505) 843-7900 FAX, [hmi@holisticmanagement.org](mailto:hmi@holisticmanagement.org)*

# Pasture Soil Assessment Sheet

Property \_\_\_\_\_ Field \_\_\_\_\_ Date \_\_\_\_\_ Examiner \_\_\_\_\_

Points	Living organism types	Earthworm holes	Earth-worms	Soil smell	Aggregation	Water infiltration	Water infiltration	Soil penetration
	species/circle	#/circle	#/shovel	score <sup>a</sup>	score <sup>b</sup>	time <sup>c</sup>	distance <sup>d</sup>	inches
Site I	1							
	2							
Site II	1							
	2							
Site III	1							
	2							
Totals								
Average*								

<sup>a</sup> smell score = 0 putrid/chemical/sour; 2 no smell; 4 fresh/earthy/sweet; for in-between smell, use odd numbers 1 or 3.

<sup>b</sup> aggregation score – 1 = broke apart in water after 1 minute; 2 = broke apart after gentle swirling; 3 = intact after gentle swirling; 4 = intact after vigorous swirling

<sup>c</sup> time required for water to infiltrate into the soil

<sup>d</sup> distance across wet spot at widest point

\* divide the total in each column by 6

## Supporting Information

1. Are there signs of erosion in this field? yes \_\_\_\_\_ no \_\_\_\_\_

2. List the crops and practices done in this field in the last 2 years: \_\_\_\_\_

\_\_\_\_\_

\_\_\_\_\_

\_\_\_\_\_

\_\_\_\_\_

## Comments:

**Assessing the Pasture Soil Resource**

By Preston Sullivan, NCAT Agriculture Specialist

Published 2001

Updated April 2010 by Hannah Sharp, NCAT Intern

© NCAT

Holly Michels, Editor

Amy Smith, Production

This publication is available on the Web at:

[www.attra.ncat.org/attra-pub/pastsoil.html](http://www.attra.ncat.org/attra-pub/pastsoil.html)

or

[www.attra.ncat.org/attra-pub/PDF/pastsoil.pdf](http://www.attra.ncat.org/attra-pub/PDF/pastsoil.pdf)

IP128

Slot 46

Version 042810

# A Brief Overview of Nutrient Cycling in Pastures

LIVESTOCK SYSTEMS GUIDE

*Abstract: Nutrients in a pasture system cycle through soil organisms, pasture plants, and grazing livestock. Appropriate management can enhance the nutrient cycle, increase productivity, and reduce costs. Two practical indicators of soil health are the number of earthworms and the percentage of organic matter in the soil. A diversity of pasture plants growing on healthy soils use sunlight and the nutrient resources in the soil to effectively produce animal feed. Paddock design and stocking density can also affect the efficiency of nutrient cycling in a pasture system. Supplementation of natural fertility, based on soil tests, balances the soil's mineral composition, resulting in better plant and animal growth and increased soil health.*

By **Alice E. Beetz**  
NCAT Agriculture Specialist  
November 2002

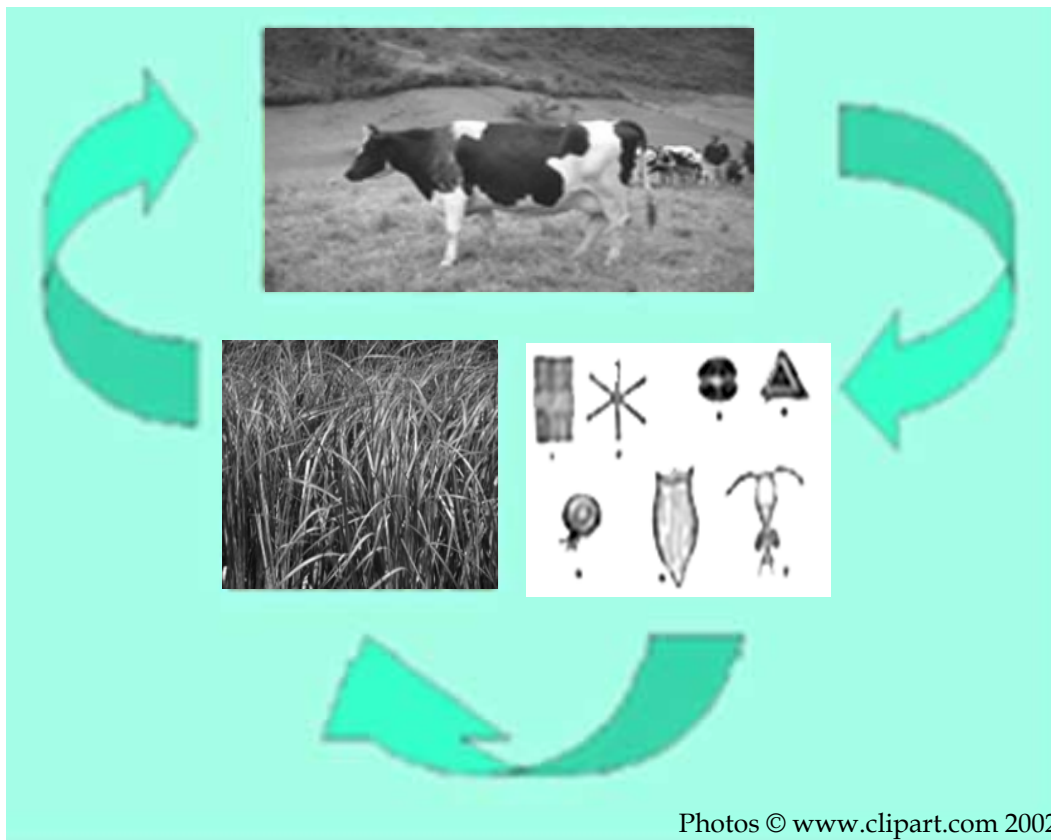

ATTRA is the national sustainable agriculture information service, operated by the National Center for Appropriate Technology through a grant from the Rural Business-Cooperative Service, U.S. Department of Agriculture. These organizations do not recommend or endorse products, companies, or individuals. NCAT has offices in Fayetteville, Arkansas (P.O. Box 3657, Fayetteville, AR 72702), Butte, Montana, and Davis, California.



## Table of Contents

<b>Introduction .....</b>	<b>2</b>
<b>Soil Organisms and Nutrient Cycling .....</b>	<b>2</b>
<b>Organic Matter is Essential to Soil Health .....</b>	<b>4</b>
<b>Pasture Plants Also Cycle Nutrients .....</b>	<b>5</b>
<b>Grazing Livestock Affect Pasture Nutrient Cycles .....</b>	<b>5</b>
<b>Nutrient Cycling in Relation to Other Natural Cycles .....</b>	<b>7</b>
<b>Supplementing the Nutrient Cycle .....</b>	<b>8</b>
<b>Conclusion .....</b>	<b>9</b>
<b>References .....</b>	<b>9</b>
<b>Further Resources .....</b>	<b>10</b>

## Introduction

When nutrients cycle efficiently in a pasture system, they move through various soil organisms and pasture plants, then through the grazing animals, and back to the soil again as manure and urine. This publication provides a general outline of the nutrient cycle, and gives pasture managers some guidelines for working with the many elements of these complex systems. For more detail and more technical information, refer to the companion ATTRA publication, [Nutrient Cycling in Pastures](#).

Pasture managers can effectively increase soil fertility by understanding the functions of the plants and animals living in and on the soil. Not only can soil organisms generate mineral nutrients or make them available, but these same minerals can also be recycled several times in a growing season, if the soil ecosystem is healthy and plant cover is optimal. With good management, nutrients can cycle quickly with minimal losses to air and water. Less fertilizer will be required, and this means increased profitability for the entire farm.

Three different groups of living organisms drive the nutrient cycle: soil organisms, pasture plants,

and grazing livestock. Each will be discussed separately below. They all work together to produce good-quality soils, which in turn produce good-quality pastures. Good-quality soils don't erode, since water flows quickly into the ground and is stored there. Good-quality pastures are springy underfoot, with deep green forage that covers the soil and a moderate amount of dead residue under the canopy. They produce nutritious forage with balanced mineral levels. Livestock find these forages palatable and thrive on them. Animal manure and plant residues quickly break down to be used again.

Producers create this kind of soil through good management. They use smart grazing strategies. They test their soils regularly and apply fertilizers, lime, and organic amendments as needed. They monitor the results of these decisions and make note of their observations for future reference. They understand their forages and adjust stocking rates and paddock rest periods. They make harvesting and seeding decisions to maintain and improve their soil and pasture resources.

## Soil Organisms and Nutrient Cycling

The soil is alive with organisms, ranging from visible insects and earthworms to microscopic bacteria and fungi. These living organisms are working for the grass farmer, to whom they are extremely important. We might even refer to them as *soil livestock*. In fact, the soil can be viewed as home to a great complexity of life, rather than just a medium to support plants. An acre of living soil may contain 900 pounds of earthworms, 2400 pounds of fungi, 1500 pounds of bacteria, 133 pounds of protozoa, 890 pounds of arthropods and algae, and even small mammals in some cases (1). An understanding of underground biological cycling can enable the pasture manager to benefit from this herd of soil livestock.

Soil bacteria are the most numerous, with every gram of soil containing at least a million of these tiny one-celled organisms. There are many different species of bacteria, each with its own role in the soil environment. One of the major

benefits bacteria provide for plants is to help them take up nutrients. One of the primary ways they do this is by releasing nutrients from organic matter and soil minerals. Certain species release nitrogen, sulfur, phosphorus, and trace elements from organic matter. Other species break down some soil minerals and release potassium, phosphorus, magnesium, calcium, and iron. Still other species make and release plant growth hormones, which stimulate root activity. Some bacteria, either living inside the roots of legumes or free-living in the soil, fix nitrogen. Other services provided to plants by various species of bacteria include improving soil structure, fighting root diseases, and detoxifying the soil.

Actinomycetes are thread-like bacteria that look like fungi. While not as numerous as other bacteria, they perform vital roles in the soil. Like other bacteria, they help decompose organic matter into humus, releasing nutrients. They also produce antibiotics to fight root diseases. And they are responsible for the sweet earthy smell of biologically active soil.

Fungi come in many different species, sizes, and shapes in soil. Some species appear as thread-like colonies, while others are one-celled yeasts. Slime molds and mushrooms are also fungi. Many fungi aid plants by breaking down organic matter or by releasing nutrients from soil minerals. Some produce hormones and antibiotics that enhance root growth and provide disease suppression. There are even species of fungi that trap harmful plant-parasitic nematodes. Mycorrhizae are fungi that live either on or in plant roots and act to extend the reach of root hairs into the soil. Mycorrhizae increase the uptake of water and nutrients, especially in soils with nutrient deficiencies. The fungi, in turn, benefit by taking nutrients and carbohydrates from the plant roots they live with.

Many species of algae also live in the soil. Unlike most other soil organisms, algae produce their own food through photosynthesis. They appear as a greenish film on the soil surface following a rain. Their primary role is to improve soil structure by producing sticky materials that glue soil particles together into water-stable aggregates. A soil aggregate looks like a miniature

crumb of granola. In addition, some species of algae (the blue-greens) can fix nitrogen, some of which is later released to plant roots.

Protozoa are free-living animals that crawl or swim in the water between soil particles. Many soil protozoa species are predatory, eating other microbes. By consuming bacteria, protozoa speed up the release of nitrogen and other nutrients through their waste products.

Nematodes are abundant in most soils, and only a few species are harmful to plants. The harmless species eat decaying plant litter, bacteria, fungi, algae, protozoa, and other nematodes. Like the other soil predators, nematodes speed the rate of nutrient cycling.

These living organisms are working for the grass farmer, to whom they are extremely important. We might even refer to them as *soil livestock*.

Earthworms are good indicators of soil health. Research in New Zealand pastures has repeatedly shown improved soil qualities where worms thrive. Studies have also proved that forage production nearly doubles when worms are introduced and establish themselves in pastures. This higher production might be attributed to other related changes, not just the direct activity of the worms themselves. Nevertheless, there is a demonstrated correlation between worm population and forage production (2).

Earthworm burrows enhance water infiltration and soil aeration. Earthworms pass soil, organic matter, and soil microbes through their digestive systems as they move through the soil. This process increases the soil's soluble nutrient content considerably. Worms eat dead plant material left on top of the soil and redistribute the organic matter and plant nutrients throughout the soil horizon. Research shows that a thick layer of dead organic material remains on the surface in pastures without any worms. Earthworms also secrete a material that stimulates plant growth. Some increase in plant growth, as well as the improved soil quality, can

be attributed to this substance. In addition, a Dutch study revealed that worms reduced the transmission of some parasitic nematodes in cow pats (3).

As Charles Griffith of the Noble Foundation has said, you can never have too many earthworms. He was working toward a goal of 25 per square foot, but reports from New Zealand mention 40 per square foot in soils where worms were introduced only seven years earlier (4). Earthworms thrive where there is no tillage, especially in the spring and fall, their most active periods. They prefer a near-neutral pH, moist soil, and plenty of plant residue on top. They are sensitive to some pesticides. Fertilizers applied to the soil surface are often beneficial, but anhydrous ammonia is deadly, and tillage destroys nightcrawler burrows. Efforts to protect and increase worm populations will be rewarded with healthier, more productive pastures.

In addition to earthworms, there are many other species of soil organisms visible to the naked eye. Among them are dung beetles, sowbugs, millipedes, centipedes, slugs, snails, and springtails. These are the primary decomposers. They start eating the large particles of plant residue. Some bury residue, bringing it in contact with other soil organisms, which further decompose it. The springtails eat mostly fungi, and their waste is rich in plant nutrients. All these organisms – from the tiny bacteria up to the large earthworms and snails – function together in a whole-soil ecosystem. Because humans cannot see most of the critters living in the soil and may not take time to observe the visible ones, it is easy to forget about them. They are present in biologically active soils and perform many useful functions, if pastures are managed for their survival.

## Organic Matter is Essential to Soil Health

Organic matter is critical for storing water and nutrients in the soil. It holds nutrients in plant-available forms that don't easily wash away. It

creates an open soil structure into which water, dissolved minerals, and oxygen can move, ready for plants to use. It provides further nutrient storage in the soil and can disable certain plant toxins. In addition, beneficial soil organisms depend upon organic matter as a source of food. These countless tiny plants and animals create an ecosystem that releases mineral nutrients, increases their availability to plants, and helps protect plant roots from disease.

Testing for soil organic matter (OM) is a simple way to make sure there is a functioning community of organisms in the soil. All the organisms mentioned above, except algae, depend on organic matter for their food. The primary decomposers start with raw plant residues and manure. Their by-products are eaten by other species whose wastes feed still other microbes. After moving through several species, these raw materials become soluble plant nutrients and humus. The humus contributes to well-structured soil, which in turn produces high-quality forage. It is clear that when this soil ecosystem is working, there are many benefits to the pasture system visible above ground. The complex ecosystem underground would be hard to evaluate, but soil organic matter, as measured in regular soil tests, is a simplified way to monitor the health of this invisible world.

The organic matter test can be requested through local Extension facilities. This kind of soil analysis measures, by weight, the percentage of soil that is OM. Organic matter includes minerals that are part of living organisms, as well as dead plant material that has not yet been digested. Because organic matter levels are harder to maintain in warmer, more humid climates, what constitutes a "high" or "low" percentage will vary in different parts of the country. Local Extension agents or soil scientists can help define relative values. A single test will show a beginning point, and subsequent soil tests can indicate whether progress is being made toward a higher level of soil organic matter.

Maintaining or building organic matter is the first step to developing soil humus. Humus results

from the final stages of organic matter decomposition. Favorable biological processes which decompose the organic matter into humus can be limited or even stopped by lack of nitrogen, lack of oxygen, unfavorable temperature, or unfavorable pH. Once stable humus has accumulated in the soil, it has a host of beneficial effects on plants. These positive effects are directly related to the presence and diversity of microbial life.

***Benefits of a humus-rich soil include:***

- Granulation of soil particles into water-stable aggregates
- Decreased crusting
- Improved internal drainage
- Better water infiltration
- Fixation of atmospheric nitrogen
- Release of bound nutrients
- Increased water and nutrient storage capacity

## **Pasture Plants Also Cycle Nutrients**

Rhizobium bacteria live in legume root nodules and convert nitrogen from the air into forms the legume can use. This nitrogen is used by the plant and generally does not become available to nearby plants until the legume dies. Some of the nitrogen fixed by white clover, however, is available as soon as four months into the season. With red clover, the interval is six months, and alfalfa-fixed nitrogen takes 6 to 12 months to become available. Although white clover is credited with fixing less nitrogen than either red clover or alfalfa, if that nitrogen is available sooner, with efficient nutrient cycling it could be used more than once in a growing season. It therefore becomes just as important as other legumes as a source of new nitrogen in the nutrient cycle. In addition, some nodules separate naturally from the legume roots during a grazing cycle, thus becoming available to other plants. Some legumes have “leaky” nodules and share more of their fixed nitrogen than others.

A nitrogen molecule can be fixed by white clover in one day. If eaten by a cow and excreted in

urine, it could take as little as two weeks before it’s again available in plant tissue. If the clover isn’t eaten directly, the nitrogen that it harvested from the air may naturally become available to nearby grasses in as little as four months. Nitrogen in a leaf that falls on biologically active soil can be used again in the same growing season.

A final way in which nutrients become available to the forage plants (and thus to the grazing animal) is through the action of deeply rooted plants. Trees, many broadleaf weeds, and forages such as alfalfa have taproots that go deep into the soil horizon where some grass roots cannot reach. The nutrients from these deeper soil levels are used by the plant, but become available at the soil surface once the tree leaves fall or the weeds die, decompose, and release their nutrients.

The roots constitute at least half the weight of a grass plant. Many native warm-season perennial grasses have root systems that reach six feet or more into the soil horizon. They occupy a huge underground area and form a network that holds the soil in place. Every year 20–50% of this mass, as well as all of the top growth in temperate climates, dies and becomes organic matter which, in biologically active soil, is broken down quickly. Cool-season grasses also contribute organic matter through root and shoot dieback.

## **Grazing Livestock Affect Pasture Nutrient Cycles**

Livestock feeding on pasture use a small proportion of the minerals they ingest in forages to build bones, meat, and hide. The rest is excreted in dung and urine. In general, urine contains most of the nitrogen (N) and potassium (K) wastes, and dung contains most of the phosphorus (P) the animals don’t use. Refer to the box on page six to learn about the value of urine and dung in pastures.

Nutrients in urine are soluble and move in the soil solution to the roots. When N and K are present at higher levels in the feed, they are

excreted in manure as well. The liquid forms can be taken up by a plant at once and are then very quickly available again as food. Sheep, which do not avoid urine spots as cattle do, can immediately cycle this mineral again.

### *Value Of NPK In Manure And Urine*

One 1000-pound cow produces 50–60 lbs. of manure and urine per day, which contains:

0.35 lb. N @ 24¢/lb. = 8¢ N  
0.23 lb. P @ 22¢/lb. = 5¢ P  
0.28 lb. K @ 14¢/lb. = 4¢ K  
Total NPK = 17¢

Therefore:

10 cows ⇒ \$ 1.70/day  
100 cows ⇒ \$17.00/day  
500 cows ⇒ \$85.00/day

Note: If you add the value of organic matter and trace minerals in the manure, the total value of the manure doubles!

Source: Salatin, Joel. 1993. *One Cow Day of Manure: What's It Worth*. *Stockman Grass Farmer*. September. p. 11.

Phosphorus and some other minerals cycle through animals primarily in manure. It can take from six months to two years for manure to break down and for the phosphorus to cycle back into the plants. The speed of the cycle is affected by various biological agents as well as by mechanical means. Dung beetles bury manure with their eggs in burrows. This activity not only places the minerals back into the roots can use them but it prevents fly eggs from hatching as well. Some pesticides designed to control livestock parasites unfortunately kill dung beetles as well. This side effect can deal a serious blow to the ability of the natural ecosystem to function. For more information on this subject, call and request [\*Dung Beetle Benefits in the Pasture Ecosystem\*](#) or find it on the ATTRA website (<http://www.attra.ncat.org>).

Other agents that help to break up manure piles include ants, birds, and earthworms. Pesticides that are lethal to these non-target species can thus have unforeseen negative consequences for nutrient availability. If dragging or clipping is economical, these operations physically scatter the dung so that smaller organisms can cycle it. The potential of creating a larger area of forage rejection, however, is a consideration. Another negative effect is that more nutrients are lost into the air during mechanical scattering.

To recapture and evenly distribute these nutrients for soil organisms and plants to use requires some knowledge about grazing behavior. In smaller paddocks, with high stock density, urine and dung are more evenly distributed than in large ones. Livestock are less selective in their grazing habits and space themselves more evenly within the area allotted for a grazing period. They will graze closer to dung piles and exhibit less avoidance of urine spots so that more forage is used for animal production.

In large areas, cattle act as a herd and go to water together. When water is available nearby, however, animals drink individually and return to graze in other areas. If they must travel in a lane to the water, manure will concentrate in these non-productive areas en route. When there is not enough room at the water tank for all to water at once, those waiting will manure that area, concentrating nutrients where they are less likely to contribute to plant and animal productivity.

Good management helps distribute nutrients that will feed soil microbes and encourage healthy soil ecosystems. Locating water, minerals, shade, and fly-control devices in different parts of the paddock also discourages nutrient concentration. It is even more beneficial if these high-use areas can be relocated for each grazing cycle or placed in areas that would not otherwise attract livestock use. Supplemental feed, likewise, should be placed either where nutrients are needed or under the fence. The location should vary with each feeding.

## Nutrient Cycling in Relation to Other Natural Cycles

Two other cycles—water and energy—interact with the nutrient cycle. They are separated for purposes of discussion here, but in reality they function as a whole system.

### *Water Cycle*

Water is a nutrient, in one sense, since it is one of the raw ingredients used by plants to make carbohydrates. It is also key to nutrient cycling because plant nutrients are soluble and move with water. Downward leaching of plant nutrients occurs with water movement. Soil itself moves in water, taking with it insoluble nutrients such as phosphorus. The area around roots must be moist, since nutrients are taken up dissolved in water.

Management determines how effective the water cycle will be in pastures. If rainwater can enter the soil easily, runoff losses are less. Maximum infiltration of rainfall keeps groundwater tables charged up, wells running year round, and drought damage to a minimum.

Soil surface conditions that foster high rainwater intake are abundant ground cover (by living plants and surface litter) and good soil aggregation. The best-aggregated soils are those that have been in well-managed perennial grass (5). Though aggregation can be maintained under crops, the perennial activity of grass provides both aggregate-forming processes and aggregate-stabilizing humus.

A grass sod extends a mass of fine roots throughout the topsoil. The grass sod also provides protection from raindrop impact. A moderate amount of thatch continually provides food for soil microorganisms and earthworms that generate the glue-like substances that bind aggregates into water-stable units. The dead material, as well as the plants themselves, shade the soil, maintaining a cooler temperature and higher humidity at the soil surface.

Conditions that reduce water intake and percolation are bare ground, surface crusting, compaction, and soil erosion. These conditions are not usually present in well-managed perennial pastures. Bare ground leads to erosion, crusting, and weeds. Crusting seals the soil surface when the soil aggregates break down. Excessive trampling—especially in wet conditions—and the impact of falling raindrops on bare soil are two common causes of crusting. Therefore, it is important to move water sources, feedbunks, and minerals before bare ground and crusting develop.

### *Energy Cycle*

The energy cycle is powered by sunlight, which plants convert into carbohydrates. In order to capture the most solar energy, the plant canopy needs to be very dense. If the pasture has both broadleaf plants and grasses, the different leaf orientations further increase energy transformation. Taller plants receive light, even at the extreme angles of sunrise and sunset. Horizontal leaves capture the noon sun better than upright grass leaves. Increased efficiency in energy conversion can be achieved if the pasture is considered a three-dimensional solar collector. Even trees, if they are trimmed high and do not make dense shade, contribute to such a system.

Energy from plants is also transferred into the soil ecosystem through the death and decay of plant roots and residue. The plant roots and residue are decomposed first by soil-dwelling insects and other primary decomposers. The waste and by-products from the primary decomposers are broken down still further by secondary decomposers. Finally the components of the residue become humus. At each step of the decomposition process, energy is either being used to create the next generation of decomposer or is lost as heat. The energy cycle and the nutrient and water cycles require a biologically active soil to function.

A thick stand of green plants covering the soil for as long a time as possible creates high energy

### ***Farm Nutrient Budget***

#### *Nutrients imported to the farm in:*

- Purchased livestock
- Chemical fertilizers
- Manures from off-farm (credit for multiple years)
- Livestock feed (grain, hay)
- Wind and water

#### *Nutrients generated on the farm:*

- Atmospheric nitrogen captured by legumes
- Rock minerals dissolved by microbial acids
- Subsoil minerals mined by deep roots of trees and other plants
- Nutrients made available to the crop by changes in pH

#### *Nutrients exported from the farm:*

- In products sold (crops, livestock)
- By wind and water (erosion)
- By leaching into groundwater
- Volatilized as gas

flow. This good-quality forage, provided to livestock at the right stage of maturity, is the next link in the energy cycle. Livestock convert plant material into meat, milk, and fiber. The leftovers become urine and manure. Livestock products are sold, and the waste products again cycle through the decomposer organisms. Minimal loss of energy depends on proper stocking rates, good decisions about when animals are moved, and how much rest the plants require.

## **Supplementing the Nutrient Cycle**

One of the first steps in assessing the nutrient cycle on any farm is to consider nutrient inputs and outputs. In what forms do nutrients enter the farm? What nutrients leave and in what form? What nutrients are generated or made available on the farm? The box above provides some examples.

Lime is a particularly important amendment in pasture management. While it has always been considered necessary for adjusting pH, there is growing evidence that the amount of calcium has

important consequences for plant production and animal health. Allan Nation, editor of *The Stockman Grass Farmer* and student of grass-based livestock systems, listed many reasons to apply agricultural lime annually. His list is reproduced below.

Soil tests, taken according to recommended procedures (consult Extension), provide a basic analysis of plant nutrient levels in a pasture. Fertilizer recommendations that accompany test results, however, are typically based on the assumption that forages will be harvested and removed from the area. In a grazing system this is not necessarily so.

### ***Lime***

200–500 lbs. of finely ground, face-powder-consistency ag lime applied annually:

- Helps prevent weeds such as dandelion, plantain, chickweed, and buttercup.
- Helps with the movement and absorption of phosphorus, nitrogen, and magnesium.
- Benefits bacteria, fungi, protozoa and other soil life so important for nutrient cycling.
- Releases important trace and growth nutrients by its pH-altering effect.
- Helps clover, which requires twice the calcium of grass. Abundant calcium is necessary for clover nodulation. No lime, little clover.
- Creates soil tilth and structure so that air and water can move more freely through soil by causing clay particles to stick together. Soil must be able to breathe to grow great grass.
- Allows pastures to hang on longer in a drought.
- Improves the palatability of grass and clover, makes the pasture softer for animals to graze, and lessens grass-pulling in new stands.
- Reportedly makes an animal more docile and content.

*Source: Nation, Allan. 1995. Quality Pasture – Part II. Stockman Grass Farmer. January. p. 13.*

Supplementing the nutrient cycle with commercial fertilizers, compost, or manure can increase both plant and animal production, which will, in turn, increase soil organic matter. In the early years of a pasture improvement plan, adding small amounts of fertilizer several times during the growing season is a good way to increase the amount of available forage. With good grazing management, more forage will translate into more pounds of livestock as well as increased soil organic matter.

To back up a fertilization program, forage samples can be taken to see what effect the fertilizer has had. Strategic forage-tissue testing can be done by taking samples between areas of poor and good growth or by making before- and after-fertilizer comparisons. County Extension agents or private consultants can explain how to take a forage sample. Because samples are analyzed for the purpose of ration balancing or to assess actual mineral content, it is necessary to specify the latter to learn whether fertilizers are achieving their purpose. More information on soils is available in the ATTRA publications [Sustainable Soil Management](#), [Alternative Soil Testing Laboratories](#) and [Assessing the Pasture Soil Resource](#).

Sole reliance on commercial fertilizer short-circuits the natural mineral cycle. High fertilization coupled with frequent harvesting of hay speeds organic matter decomposition and releases minerals faster than plants growing on the site can absorb them. As a result, nutrients are leached deeper into the soil, out of the reach of plant roots, or they are lost to run off. The use of some commercial fertilizer is always an option to be exercised when necessary. However, continuing to look for ways to use natural systems to produce nutritious forage and healthy animals, while lessening one's dependence on purchased, non-renewable resources, is worthwhile.

## Conclusion

This publication has described the many paths travelled by pasture nutrients. While some minerals leave the farm as animal products, the

majority move through a series of living beings in a continuous cycle. Some nutrients escape to the air, some are lost to water erosion, and some leach down past the reach of forage plant roots. The grazer who understands these cycles and their interactions can, by making smart daily decisions, retain more nutrients on site.

The health and growth of the grazing livestock depend on high-quality pastures, which in turn spring from the soil "livestock" in a balanced underground ecosystem. Soil organic matter and earthworm numbers are simple indicators that producers can use to monitor soil health. Good grazing management, based in part on a basic understanding of grazing behavior, combined with a knowledge of how animals affect the whole pasture system, contributes to lush pastures that livestock need only to harvest. Then, with good marketing, profit is the natural result!

For more in-depth discussion of the topics raised in this publication, consult the companion ATTRA booklet, [Nutrient Cycling in Pastures](#). Some other good resources are listed below.

## References

- 1) Pimentel, David et al. 1995. Environmental and economic costs of soil erosion and conservation benefits. *Science*. Vol. 267, No. 24. p. 1117-1122.
- 2) Stockdill, S.M.J. 1966. The effect of earthworms on pastures. *Proceedings: New Zealand Ecological Society*. Volume 13. p. 68-75.
- 3) Gronvold, Jorn. 1987. Field experiment on the ability of earthworms (Lumbricidae) to reduce the transmission of infective larvae of *Cooperia oncophora* (Trichostrongylidae) from cow pats to grass. *Journal of Parasitology*. Vol. 73, No. 6. p. 1133-1137.
- 4) Stockdill, S.M.J. 1959. Earthworms improve pasture growth. *New Zealand Journal of Agriculture*. March. p. 227-233.



- 5) Allison, F.E. 1968. Soil aggregation—some facts and fallacies as seen by a microbiologist. Soil Science. Vol. 106, No. 2. p. 136-143.

## Further Resources

### Proceedings:

Joost, Richard E. and Craig A. Roberts. 1996. **Nutrient Cycling in Forage Systems.** Proceedings of a Symposium held March 7-8, 1996, Columbia, MO. Potash and Phosphate Institute and Foundation for Agronomic Research, Manhattan, KS. 243 p.

*Anyone interested in pursuing this subject further should obtain a copy of this book. It contains many bibliographic references. Available for \$15 ppd. from:*

Potash and Phosphate Institute  
772 22nd Ave. S.  
Brooking, SD 57006  
(605) 692-6280

### Periodicals:

*These carry articles on practical aspects of grazing management, including nutrient cycling.*

#### **The Forage Leader**

American Forage and Grassland Council  
P.O. Box 891  
Georgetown, TX 78627  
(800) 944-2342

#### **Graze**

P.O. Box 48  
Belleville, WI 53508  
(608) 455-3311

<http://www.grazeonline.com>

*\$30 for 1-year subscription (10 issues)*

#### **Hay and Forage Grower**

Webb Division  
Intertec Publishing Corp.  
9800 Metcalf  
Overland Park, KS 66212-2215  
(800) 441-0294.

#### **Pasture Prophet**

Grazing Lands Technology Institute  
Pasture Systems and Watershed Research Laboratory  
Building 3702, Curtin Rd.  
University Park, PA 16802-3702

#### **The Stockman Grass Farmer**

282 Commerce Park Drive  
Ridgeland, MS 39157  
(601) 853-1861  
(601) 853-8087 FAX.  
(800) 748-9808  
<http://www.stockmangrassfarmer.com>

### Electronic Listservers:

#### **Graze-L**

To subscribe send an e-mail to:  
[majordomo@taranaki.ac.nz](mailto:majordomo@taranaki.ac.nz) or  
[listserv@taranaki.ac.nz](mailto:listserv@taranaki.ac.nz)  
In the body of the e-mail type "subscribe graze-1"

#### **The Grazer's Edge**

To subscribe send an e-mail to:  
[grazersedge-subscribe@onelist.com](mailto:grazersedge-subscribe@onelist.com)  
In the body of the e-mail type "subscribe grazersedge"

### Web Sites:

Soil Foodweb, Inc.

<http://www.soilfoodweb.com/index.html>

*More detail on the underground soil ecosystem and its above-ground interactions can be found on this website.*

#### **Related ATTRA Publications**

[Nutrient Cycling in Pastures](#)  
[Assessing the Pasture Soil Resource](#)  
[Sustainable Pasture Management](#)  
[Rotational Grazing](#)  
[Dung Beetle Benefits in the Pasture Ecosystem](#)

By **Alice E. Beetz**  
NCAT Agriculture Specialist

Edited by Richard Earles  
Formatted by Cynthia Arnold

November 2002

The electronic version of **A Brief Overview of Nutrient Cycling in Pastures** is located at:  
HTML  
<http://www.attra.ncat.org/attra-pub/nutcycle.html>  
PDF  
<http://www.attra.ncat.org/attra-pub/PDF/nutcycle.pdf>



# NUTRIENT CYCLING IN PASTURES

LIVESTOCK SYSTEMS GUIDE

By **Barbara Bellows**

**NCAT Agriculture Specialist**

**December 2001**

*Abstract: Good pasture management practices foster effective use and recycling of nutrients. Nutrient cycles important in pasture systems are the water, carbon, nitrogen, and phosphorus cycles. This publication provides basic descriptions of these cycles, and presents guidelines for managing pastures to enhance nutrient cycling efficiency — with the goal of optimizing forage and livestock growth, soil health, and water quality. Includes 19 Tables and 14 Figures.*

## Table of Contents

Introduction and Summary .....	2
Publication Overview .....	5
Chapter 1. Nutrient Cycle Components, Interactions, and .....	
Transformations .....	6
Water Cycle .....	6
Carbon Cycle .....	10
Nitrogen Cycle .....	13
Phosphorus Cycle .....	18
Secondary Nutrients .....	21
Chapter 2. Nutrient Availability in Pastures .....	23
Soil Parent Material .....	23
Soil Chemistry .....	23
Prior Management Practices .....	24
Soil Compaction .....	24
Organic Matter .....	25
Soil pH .....	27
Timing of Nutrient Additions .....	27
Chapter 3. Nutrient Distribution and Movement in Pastures .....	30
Pasture Nutrient Inputs and Outputs .....	30
Manure Nutrient Availability .....	32
Pasture Fertilization .....	33
Grazing Intensity .....	34
Diversity and Density of Pasture Plants .....	36
Chapter 4. The Soil Food Web and Pasture Soil Quality .....	40
Diversity of the Soil Food Web .....	40
Organic Matter Decomposition .....	40
Primary Decomposers .....	41
Secondary Decomposers .....	43
Soil Organisms and Soil Health .....	44
Chapter 5. Pasture Management and Water Quality .....	47
Risk Factors for Nutrient Losses .....	47
Pathogens .....	48
Nitrate Contamination .....	49
Phosphorus Contamination .....	49
Subsurface Drainage .....	51
Riparian Buffers .....	52
Riparian Grazing .....	53
References .....	55
Resource List .....	61
Agencies and Organizations .....	61
Publications in Print .....	61
Web Resources .....	63

ATTRA is the national sustainable agriculture information service operated by the National Center for Appropriate Technology under a grant from the Rural Business-Cooperative Service, U.S. Department of Agriculture. These organizations do not recommend or endorse products, companies, or individuals. ATTRA is headquartered in Fayetteville, Arkansas (P.O. Box 3657, Fayetteville, AR 72702), with offices in Butte, Montana and Davis, California.



## Introduction and Summary

As a pasture manager, what factors do you look at as indicators of high production and maximum profitability? You probably look at the population of animals stocked within the pasture. You probably look at the vigor of plant regrowth. You probably also look at the diversity of plant species growing in the pasture and whether the plants are being grazed uniformly. But do you know how much water seeps into your soil or how much runs off the land into gullies or streams? Do you monitor how efficiently your plants are taking in carbon and forming new leaves, stems, and roots through photosynthesis? Do you know how effectively nitrogen and phosphorus are being used, cycled, and conserved on your farm? Are most of these nutrients being used for plant and animal growth? Or are they being leached into the groundwater or transported through runoff or erosion into lakes, rivers, and streams? Do you know how to change your pasture management practices to decrease these losses and increase the availability of nutrients to your forages and animals?

**Figure 1. Nutrient Cycles in Pastures.**

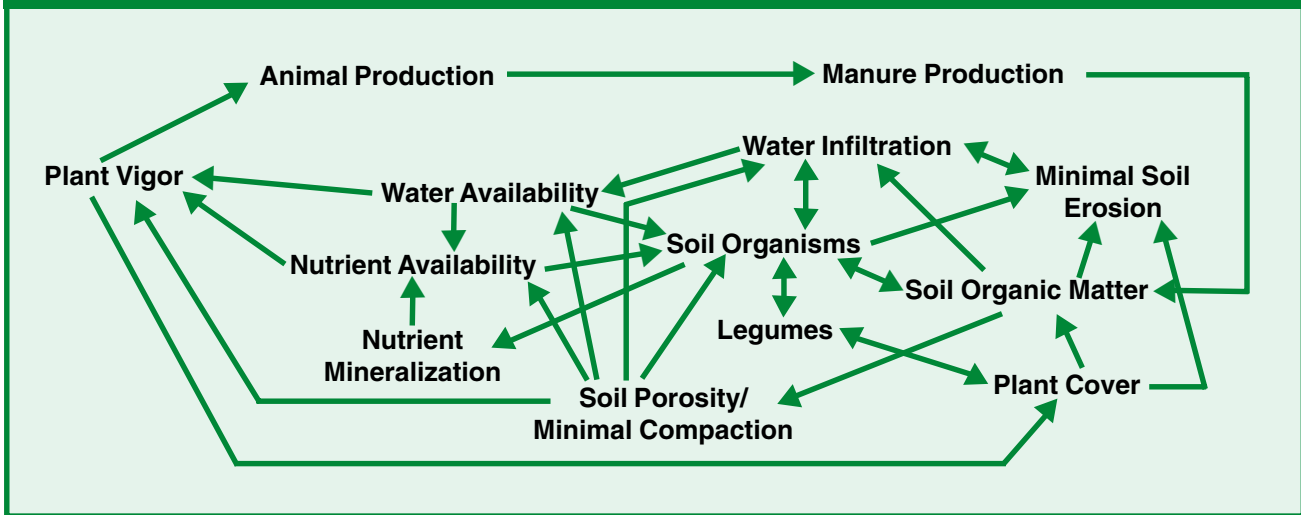

Healthy plant growth provides plant cover over the entire pasture. Cover from growing plants and plant residues protects the soil against erosion while returning organic matter to the soil. Organic matter provides food for soil organisms that mineralize nutrients from these materials and produce gels and other substances that enhance water infiltration and the capacity of soil to hold water and nutrients.

**Effective use and cycling of nutrients** is critical for pasture productivity. As indicated in [Figure 1](#) above, nutrient cycles are complex and interrelated. This document is designed to help you understand the unique components of water, carbon, nitrogen, and phosphorus cycles and how these cycles interact with one another. This information will help you to monitor your pastures for breakdowns in nutrient cycling processes, and identify and implement pasture management practices to optimize the efficiency of nutrient cycling.

### WATER

Water is necessary for plant growth, for dissolving and transporting plant nutrients, and for the survival of soil organisms. Water can also be a destructive force, causing soil compaction, nutrient leaching, runoff, and erosion. Management

practices that facilitate water movement into the soil and build the soil's water holding capacity will conserve water for plant growth and groundwater recharge, while minimizing water's potential to cause nutrient losses. Water-conserving pasture management practices include:

- Minimizing soil compaction by not overgrazing pastures or using paddocks that have wet or saturated soils
- Maintaining a complete cover of forages and residues over all paddocks by not overgrazing pastures and by implementing practices that encourage animal movement across each paddock
- Ensuring that forage plants include a diversity of grass and legume species with a variety of root systems capable of obtaining water and nutrients throughout the soil profile

## CARBON

Carbon is transformed from carbon dioxide into plant cell material through photosynthesis. It is the basic structural material for all cell life, and following the death and decomposition of cells it provides humus and other organic components that enhance soil quality. Plant nutrients such as nitrogen and phosphorus are chemically bound to carbon in organic materials. For these nutrients to become available for plant use, soil organisms need to break down the chemical bonds in a process called *mineralization*. If the amount of carbon compared to other nutrients is very high, more bonds will need to be broken and nutrient release will be slow. If the amount of carbon compared to other nutrients is low, fewer bonds will need to be broken and nutrient release will proceed relatively rapidly. Rapid nutrient release is preferred when plants are growing and are able to use the nutrients released. Slower nutrient release is preferred when plants are not actively growing (as in the fall or winter) or if the amount of nutrients in the soil is already in excess of what plants can use. Pasture management practices that favor effective carbon use and cycling include:

- Maintaining a diversity of forage plants with a variety of leaf shapes and orientations (to enhance photosynthesis) and a variety of root growth habits (to enhance nutrient uptake). A diversity of forages will provide a balanced diet for grazing animals and a variety of food sources for soil organisms
- Promoting healthy regrowth of forages by including a combination of grasses with both low and elevated growing points, and by moving grazing animals frequently enough to minimize the removal of growing points
- Maintaining a complete cover of forages and residues over all paddocks to hold soil nutrients against runoff and leaching losses and ensure a continuous turnover of organic residues

## NITROGEN

Nitrogen is a central component of cell proteins and is used for seed production. It exists in several chemical forms and various microorganisms are involved in its transformations. Legumes, in association with specialized bacteria

called rhizobia, are able to transform atmospheric nitrogen into a form available for plant use. Nitrogen in dead organic materials becomes available to plants through mineralization. Nitrogen can be lost from the pasture system through the physical processes of leaching, runoff, and erosion; the chemical process of volatilization; the biological process of denitrification; and through burning of plant residues. Since it is needed in high concentration for forage production and can be lost through a number of pathways, nitrogen is often the limiting factor in forage and crop production. Productive pasture management practices enhance the fixation and conservation of nitrogen while minimizing the potential for nitrogen losses. Practices that favor effective nitrogen use and cycling in pastures include:

- Maintaining stable or increasing percentages of legumes by not overgrazing pastures and by minimizing nitrogen applications, especially in the spring
- Protecting microbial communities involved in organic matter mineralization by minimizing practices that promote soil compaction and soil disturbance, such as grazing of wet soils and tillage
- Incorporating manure and nitrogen fertilizers into the soil, and never applying these materials to saturated, snow-covered, or frozen soils
- Avoiding pasture burning. If burning is required, it should be done very infrequently and by using a slow fire under controlled conditions
- Applying fertilizers and manure according to a comprehensive nutrient management plan

## PHOSPHORUS

Phosphorus is used for energy transformations within cells and is essential for plant growth. It is often the second-most-limiting mineral nutrient to plant production, not only because it is critical for plant growth, but also because chemical bonds on soil particles hold the majority of phosphorus in forms not available for plant uptake. Phosphorus is also the major nutrient needed to stimulate the growth of algae in lakes and streams. Consequently, the inadvertent fertilization of these waterways with runoff water from fields and streams can cause

degradation of water quality for drinking, recreational, or wildlife habitat uses. Regulations on the use of phosphorus-containing materials are becoming more widespread as society becomes increasingly aware of the impacts agricultural practices can have on water quality. Pasture management practices must balance the need to ensure sufficient availability of phosphorus for plant growth with the need to minimize movement of phosphorus from fields to streams. Pasture management practices that protect this balance include:

- Minimizing the potential for compaction while providing organic inputs to enhance activities of soil organisms and phosphorus mineralization
- Incorporating manure and phosphorus fertilizers into the soil and never applying these materials to saturated, snow-covered, or frozen soils
- Relying on soil tests, phosphorus index guidelines, and other nutrient management practices when applying fertilizers and manure to pastures

### SOIL LIFE

Soil is a matrix of pore spaces filled with water and air, minerals, and organic matter. Although comprising only 1 to 6% of the soil, living and decomposed organisms are certainly of the essence. They provide plant nutrients, create soil structure, hold water, and mediate nutrient transformations. Soil organic matter is composed of three components: stable humus, readily decomposable materials, and living organisms — also described as the very dead, the dead, and the living components of soil (1).

Living organisms in soil include larger fauna such as moles and prairie dogs, macroorganisms such as insects and earthworms, and microorganisms including fungi, bacteria, yeasts, algae, protozoa, and nematodes. These *living* organisms break down the *readily decomposable* plant and animal material into nutrients, which are then available for plant uptake. Organic matter residues from this decomposition process are subsequently broken down by other organisms until all that remains are complex compounds resistant to decomposition. These complex end products of decomposition are known as *humus*.

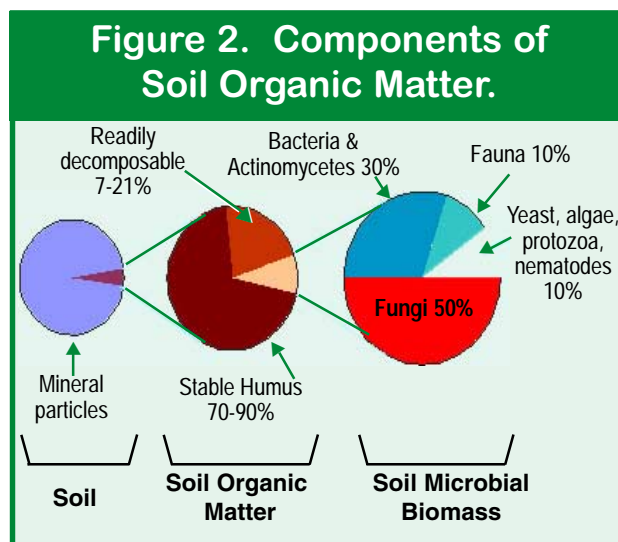

Soil contains 1-6% organic matter. Organic matter contains 3-9% active microorganisms. These organisms include plant life, bacteria and actinomycetes, fungi, yeasts, algae, protozoa, and nematodes.

Humus, along with fungal threads, bacterial gels, and earthworm feces, forms glues that hold soil particles together in *aggregates*. These constitute soil structure, enhance soil porosity, and allow water, air, and nutrients to flow through the soil. These residues of soil organisms also enhance the soil's nutrient and water holding capacity. Lichens, algae, fungi, and bacteria form biological crusts over the soil surface. These crusts are important, especially in arid rangelands, for enhancing water infiltration and providing nitrogen fixation (2). Maintaining a substantial population of legumes in the pasture also ensures biological nitrogen fixation by bacteria associated with legume roots.

Effective nutrient cycling in the soil is highly dependent on an active and diverse community of soil organisms. Management practices that maintain the pasture soil as a habitat favorable for soil organisms include:

- Maintaining a diversity of forages, which promotes a diverse population of soil organisms by providing them with a varied diet
- Adding organic matter, such as forage residues and manure, to the soil to provide food for soil organisms and facilitate the formation of aggregates
- Preventing soil compaction and soil saturation, and avoiding the addition of amendments that might kill certain populations of soil organisms

## Publication Overview

---

This publication is divided into five chapters:

1. *Nutrient cycle components, interactions, and transformations*
2. *Nutrient availability in pastures*
3. *Nutrient distribution and movement in pastures*
4. *The soil food web and pasture soil quality*
5. *Pasture management and water quality*

The first chapter provides an overview of nutrient cycles critical to plant production and water-quality protection: the water, carbon, nitrogen, phosphorus, and secondary-nutrient cycles. The components of each cycle are explained, with emphasis on how these components are affected by pasture management practices. The description of each cycle concludes with a summary of pasture management practices to enhance efficient cycling of that nutrient.

The second chapter focuses on the effects of soil chemistry, mineralogy, and land-management practices on nutrient cycle transformations and nutrient availability. Management impacts discussed include soil compaction, organic matter additions and losses, effects on soil pH, and consequences of the method and timing of nutrient additions. The chapter concludes with a summary of pasture management practices for enhancing nutrient availability in pastures.

The third chapter discusses nutrient balances in grazed pastures and the availability of manure, residue, and fertilizer nutrients to forage growth. Factors affecting nutrient availability include nutrient content and consistency of manure; manure distribution as affected by paddock location and layout; and forage diversity. These factors, in turn, affect grazing intensity and pasture regrowth. A graph at the end of the chapter illustrates the interactions among these factors.

The fourth chapter describes the diversity of organisms involved in decomposing plant residues and manure in pastures, and discusses the impact of soil biological activity on nutrient cycles and forage production. The impacts of pasture management on the activity of soil organisms are explained. A soil health card developed for pastures provides a tool for qualitatively assessing the soil's ability to support healthy populations of soil organisms.

The publication concludes with a discussion of pasture management practices and their effects on water quality, soil erosion, water runoff, and water infiltration. Several topical water concerns are discussed: phosphorus runoff and eutrophication, nutrient and pathogen transport through subsurface drains, buffer management, and riparian grazing practices. A guide for assessing potential water-quality impacts from pasture-management practices concludes this final chapter.



# Chapter 1

## Nutrient Cycle Components, Interactions, and Transformations

---

The water, carbon, nitrogen, phosphorus, and sulfur cycles are the most important nutrient cycles operating in pasture systems. Each cycle has its complex set of interactions and transformations as well as interactions with the other cycles. The water cycle is essential for photosynthesis and the transport of nutrients to plant roots and through plant stems. It also facilitates nutrient loss through leaching, runoff, and erosion. The carbon cycle forms the basis for cell formation and soil quality. It begins with photosynthesis and includes respiration, mineralization, immobilization, and humus formation. Atmospheric nitrogen is fixed into plant-available nitrate by one type of bacteria, converted from ammonia to nitrate by another set of bacteria, and released back to the atmosphere by yet another group. A variety of soil organisms are involved in decomposition processes that release or mineralize nitrogen, phosphorus, sulfur, and other nutrients from plant residues and manure. Balances in the amount of these nutrients within organic materials, along with temperature and moisture conditions, determine which organisms are involved in the decomposition process and the rate at which it proceeds.

Pasture management practices influence the interactions and transformations occurring within nutrient cycles. The efficiency of these cycles, in turn, influences the productivity of forage growth and the productivity of animals feeding on the forage. This chapter examines each of these cycles in detail and provides management guidelines for enhancing their efficiency.

---

### WATER CYCLE

---

Water is critical for pasture productivity. It dissolves soil nutrients and moves them to plant roots. Inside plants, water and the dissolved nutrients support cell growth and photosynthesis. In the soil, water supports the growth and reproduction of insects and microorganisms that decompose organic matter. Water also can degrade pastures through runoff, erosion, and leaching, which cause nutrient loss and water pollution. Productive pastures are able to absorb and use water effectively for plant growth. Good pasture management practices promote water absorption by maintaining forage cover over the entire soil surface and by minimizing soil compaction by animals or equipment.

**A forage cover over the entire paddock promotes water infiltration and minimizes soil compaction.**

Geology, soil type, and landscape orientation affect water absorption by soils and water movement through soils. Sloping land encourages water runoff and erosion; depressions and footslopes are often wet since water from upslope collects in these areas. Clay soils absorb water and nutrients, but since clay particles are very

small, these soils can easily become compacted. Sandy soils are porous and allow water to enter easily, but do not hold water and nutrients against leaching. Organic matter in soil absorbs water and nutrients, reduces soil compaction, and increases soil porosity. A relatively small increase in the amount of organic matter in soil can cause a large increase in the ability of soils to use water effectively to support plant production.

#### INFILTRATION AND WATER HOLDING CAPACITY

Water soaks into soils that have a plant or residue cover over the soil surface. This cover cushions the fall of raindrops and allows them to slowly soak into the soil. Roots create pores that increase the rate at which water can enter the soil. Long-lived perennial bunch-grass forms deep roots that facilitate water infiltration by conducting water into the soil (3). Other plant characteristics that enhance water infiltration are significant litter production and large basal coverage (4). In northern climates where snow provides a substantial portion of the annual water budget, maintaining taller grasses and shrubs that can trap and hold snow will enhance water infiltration.



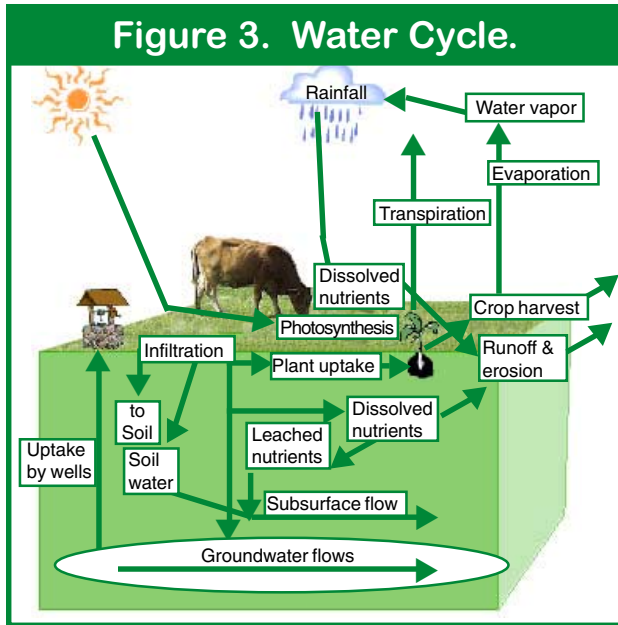

**The Water Cycle.** Rain falling on soil can either be absorbed into the soil or be lost as it flows over the soil surface. Absorbed rain is used for the growth of plants and soil organisms, to transport nutrients to plant roots, or to recharge ground water. It can also leach nutrients through the soil profile, out of the reach of plant roots. Water flowing off the soil surface can transport dissolved nutrients as runoff, or nutrients and other contaminants associated with sediments as erosion.

Soils with a high water holding capacity absorb large amounts of water, minimizing the potential for runoff and erosion and storing water for use during droughts. Soils are able to absorb and hold water when they have a thick soil profile; contain a relatively high percentage of organic matter; and do not have a rocky or compacted soil layer, such as a hardpan or plowpan, close to the soil surface. An active population of soil organisms enhances the formation of aggregates and of burrowing channels that provide pathways for water to flow into and through the soil. Management practices that enhance water infiltration and water holding capacity include:

- a complete coverage of forages and residues over the soil surface
- an accumulation of organic matter in and on the soil
- an active community of soil organisms involved in organic matter decomposition and aggregate formation
- water runoff and soil erosion prevention
- protection against soil compaction

### SOIL SATURATION

Soils become saturated when the amount of water entering exceeds the rate of absorption or drainage. A rocky or compacted lower soil layer will not allow water to drain or pass through, while a high water table prevents water from draining through the profile. Water soaking into these soils is trapped or perched above the hard

layer or high water table. Soils prone to saturation are usually located at the base of slopes, near waterways, or next to seeps.

**Impact on crop production.** Soil saturation affects plant production by exacerbating soil compaction, limiting air movement to roots, and ponding water and soil-borne disease organisms around plant roots and stems. When soil pores are filled with water, roots and beneficial soil organisms lose access to air, which is necessary for their healthy growth. Soil compaction decreases the ability of air, water, nutrients, and roots to move through soils even after soils have dried. Plants suffering from lack of air and nutrients are susceptible to disease attack since they are under stress, and wet conditions help disease organisms move from contaminated soil particles and plant residues to formerly healthy plant roots and stems.

**Runoff and erosion potential.** Soil saturation enhances the potential for runoff and erosion by preventing entry of additional water into the soil profile. Instead, excess water will run off the soil surface, often carrying soil and nutrients with it. Water can also flow horizontally under the surface of the soil until it reaches the banks of streams or lakes. This subsurface water flow carries nutrients away from roots, where they could be used for plant growth, and into streams or lakes where they promote the growth of algae and eutrophication.

**Artificial drainage** practices are often used on soils with a hardpan or a high water table to decrease the duration of soil saturation following rainfalls or snowmelts. This practice can increase water infiltration and decrease the potential for water runoff (5). Unfortunately, most subsurface drains were installed before water pollution from agriculture became a concern and thus empty directly into drainage ways. Nutrients, pathogens, and other contaminants on the soil surface can move through large cracks or channels in the soil to drainage pipes where they are carried to surface water bodies (6).

### SOIL COMPACTION

Soil compaction occurs when animals or equipment move across soils that are wet or saturated, with moist soils being more easily compacted than saturated soils (7). Compaction can also occur when animals or equipment continually move across a laneway or stand around watering tanks and headlands or under shade. Animals trampling over the ground press down on soils, squeezing soil pore spaces together. Trampling also increases the potential for compaction by disturbing and killing vegetation.

Soils not covered by forages or residues are easily compacted by the impact of raindrops. When raindrops fall on bare soil, their force causes fine soil particles to splash or disperse. These splash particles land on the soil surface, clog surface soil pores, and form a crust over the soil. Clayey soils are more easily compacted than sandy soils because clay particles are very small and sticky.

**Animals trampling over the ground press down on soils, squeezing soil pores together, which limits root growth and the movement of air, water, and dissolved nutrients.**

Compaction limits root growth and the movement of air, water, and dissolved nutrients through the soil. Compressing and clogging soil surface pores also decreases water infiltration and increases the potential for runoff. The formation of hardpans, plowpans, traffic pans, or other compacted layers decreases downward movement of water through the soil, causing rapid soil saturation and the inability of soils to absorb additional water. Compaction in pas-

tures is remediated by root growth, aggregate formation, and activities of burrowing soil organisms. In colder climates, frost heaving is an important recovery process for compacted soils (8).

### RUNOFF AND EROSION

Runoff water dissolves nutrients and removes them from the pasture as it flows over the soil surface. Soil erosion transports nutrients and any contaminants, such as pesticides and pathogens, attached to soil particles. Because nutrient-rich clay and organic matter particles are small and lightweight, they are more readily picked up and moved by water than the nutrient-poor, but heavier, sand particles. Besides depleting pastures of nutrients that could be used for forage production, runoff water and erosion carry nutrients and sediments that contaminate lakes, streams, and rivers.

Landscape conditions and management practices that favor runoff and erosion include sloping areas, minimal soil protection by forage or residues, intense rainfall, and saturated soils. While pasture managers should strive to maintain a complete forage cover over the soil surface, this is not feasible in practice because of plant growth habits and landscape characteristics. Plant residues from die-back and animal wastage during grazing provide a critical source of soil cover and organic matter. As mentioned above, forage type affects water infiltration and runoff. Forages with deep roots enhance water infiltration while plants with a wide vegetative coverage area or prostrate growth provide good protection against raindrop impact. Sod grasses that are short-lived and shallow-rooted inhibit water infiltration and encourage runoff. Grazing practices that produce clumps of forages separated by bare ground enhance runoff potential by producing pathways for water flow.

**Runoff water and erosion carry nutrients and sediments that contaminate lakes, streams, and rivers.**

### EVAPORATION AND TRANSPIRATION

Water in the soil profile can be lost through evaporation, which is favored by high temperatures and bare soils. Pasture soils with a thick cover of grass or other vegetation lose little water to evaporation since the soil is shaded and soil temperatures are decreased. While evapo-

ration affects only the top few inches of pasture soils, transpiration can drain water from the entire soil profile. Transpiration is the loss of water from plants through stomata in their leaves. Especially on sunny and breezy days, significant amounts of water can be absorbed from the soil by plant roots, taken up through the plant, and lost to the atmosphere through transpiration. A diversity of forage plants will decrease transpiration losses and increase water-use efficiency.

This is because forage species differ in their ability to extract water from the soil and conserve it against transpiration (9). Some invasive plant species, however, can deplete water stores through their high water use (4). Water not used for immediate plant uptake is held within the soil profile or is transported to groundwater reserves, which supply wells with water and decrease the impacts of drought.

**Table 1. Water Cycle Monitoring.**

If you answer no to all the questions, you have soils with high water-use efficiency. If you answer yes to some of the questions, water cycle efficiency of your soil will likely respond to improved pasture management practices. See Table 2, next page.

	YES	NO
<b><u>Water infiltration / Water runoff</u></b>		
1. Do patches of bare ground separate forage coverage?		
2. Are shallow-rooted sod grasses the predominant forage cover?		
3. Can you see small waterways during heavy rainfalls or sudden snowmelts?		
4. Are rivulets and gullies present on the land?		
<b><u>Soil saturation</u></b>		
5. Following a rainfall, is soil muddy or are you able to squeeze water out of a handful of soil?		
6. Following a rainfall or snowmelt, does it take several days before the soil is no longer wet and muddy?		
7. Do forages turn yellow or die during wet weather?		
<b><u>Soil compaction</u></b>		
8. Do you graze animals on wet pastures?		
9. Are some soils in the pasture bare, hard, and crusty?		
10. Do you have difficulty driving a post into (non-rocky) soils?		
<b><u>Water retention /Water evaporation and transpiration</u></b>		
11. Do you have a monoculture of forages or are invasive species prominent components of the pasture?		
12. Do soils dry out quickly following a rainstorm?		
13. During a drought, do plants dry up quickly?		

**Table 2. Pasture Management Practices for Efficient Water Cycling in Pastures.**

**Ensure forage and residue coverage across the entire pasture**

- Use practices that encourage animal movement throughout the pasture and discourage congregation in feeding and lounging areas
- Use practices that encourage regrowth of forage plants and discourage overgrazing
- Use a variety of forages with a diversity of root systems and growth characteristics

**Pasture management during wet weather**

- Use well-drained pastures or a “sacrificial pasture” that is far from waterways or water bodies
- Avoid driving machinery on pastures that are wet or saturated
- Avoid spreading manure or applying fertilizers

**Artificial drainage practices**

- Avoid grazing animals on artificially drained fields when drains are flowing
- Avoid spreading manure or applying fertilizers when drains are flowing
- Ensure that drains empty into a filter area or wetland rather than directly into a stream or drainage way

---

## CARBON CYCLE

---

Effective carbon cycling in pastures depends on a diversity of plants and healthy populations of soil organisms. Plants form carbon and water into carbohydrates through photosynthesis. Plants are most able to conduct photosynthesis when they can efficiently capture solar energy while also having adequate access to water, nutrients, and air. Animals obtain carbohydrates formed by plants when they graze on pastures or eat hay or grains harvested from fields. Some of the carbon and energy in plant carbohydrates is incorporated into animal cells. Some of the carbon is lost to the atmosphere as carbon dioxide, and some energy is lost as heat, during digestion and as the animal grows and breathes.

**Humus maintains soil tilth and enhances water and nutrient absorption.**

Carbohydrates and other nutrients not used by animals are returned to the soil in the form of urine and manure. These organic materials provide soil organisms with nutrients and energy. As soil organisms use and decompose organic materials, they release nutrients from these materials into the soil. Plants then use the released, inorganic forms of nutrients for their growth and reproduction. Soil organisms also use nutrients from organic materials to produce substances that bind soil particles into aggregates. Residues of organic matter that resist further decomposition by soil organisms form *soil humus*. This stable organic material is critical for maintaining soil tilth and enhancing the ability of soils to absorb and hold water and nutrients.

---

### CARBOHYDRATE FORMATION

For productive growth, plants need to effectively capture solar energy, absorb carbon dioxide, and take up water from the soil to produce carbohydrates through photosynthesis. In pastures, a combination of broadleaf plants and grasses allows for efficient capture of solar en-

ergy by a diversity of leaf shapes and leaf angles. Taller plants with more erect leaves capture light even at the extreme angles of sunrise and sunset. Horizontal leaves capture the sun at midday or when it is more overhead.

Two methods for transforming carbon into carbohydrates are represented in diversified pas-

**Figure 4. Carbon Cycle.**

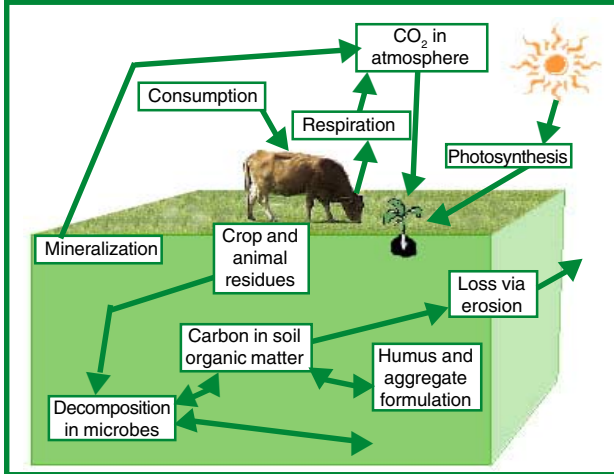

*The Carbon Cycle begins with plants taking up carbon dioxide from the atmosphere in the process of photosynthesis. Some plants are eaten by grazing animals, which return organic carbon to the soil as manure, and carbon dioxide to the atmosphere. Easily broken-down forms of carbon in manure and plant cells are released as carbon dioxide when decomposing soil organisms respire. Forms of carbon that are difficult to break down become stabilized in the soil as humus.*

tures. Broadleaf plants and cool-season grasses have a photosynthetic pathway that is efficient in the production of carbohydrates but is sensitive to dry conditions. Warm-season grasses have a pathway that is more effective in producing carbohydrates during hot summer conditions. A combination of plants representing these two pathways ensures effective forage growth throughout the growing season. A diversity of root structures also promotes photosynthesis by giving plants access to water and nutrients throughout the soil profile.

### ORGANIC MATTER DECOMPOSITION

Pasture soils gain organic matter from growth and die-back of pasture plants, from forage waste during grazing, and from manure deposition. In addition to the recycling of aboveground plant parts, every year 20 to 50% of plant root mass dies and is returned to the soil system. Some pasture management practices also involve the regular addition of manure from grazing animals housed during the winter or from poultry, hog, or other associated livestock facilities.

A healthy and diverse population of soil organisms is necessary for organic matter decomposition, nutrient mineralization, and the formation of soil aggregates. Species representing almost every type of soil organism have roles in the breakdown of manure, plant residues, and dead organisms. As they use these substances for food and energy sources,

they break down complex carbohydrates and proteins into simpler chemical forms. For example, soil organisms break down proteins into carbon dioxide, water, ammonium, phosphate, and sulfate. Plants require nutrients to be in this simpler, decomposed form before they can use them for their growth.

To effectively decompose organic matter, soil organisms require access to air, water, and nutrients. Soil compaction and saturation limit the growth of beneficial organisms and promote the growth of anaerobic organisms, which are inefficient in the decomposition of organic matter. These organisms also transform some nutrients into forms that are less available or unavailable to plants. Nutrient availability and nutrient balances in the soil solution also affect the growth and diversity of soil organisms. To decompose organic matter that contains a high amount of carbon and insufficient amounts of other nutrients, soil organisms must mix soil- solution nutrients with this material to

achieve a balanced diet.

Balances between the amount of carbon and nitrogen (C:N ratio) and the amount of carbon and sulfur (C:S ratio) determine whether soil organisms will release or immobilize nutrients

when they decompose organic matter. *Immobilization* refers to soil microorganisms taking nutrients from the soil solution to use in the decomposition process of nutrient-poor materials. Since these nutrients are within the bodies of soil

**A healthy and diverse population of soil organisms is necessary for organic matter decomposition, nutrient mineralization, and the formation of soil aggregates.**

organisms, they are temporarily unavailable to plants. In soils with low nutrient content, this can significantly inhibit plant growth. However, immobilization can be beneficial in soils with excess nutrients. This process conserves nutrients in bodies of soil organisms, where they are less likely to be lost through leaching and runoff (10).

Populations of soil organisms are enhanced by soil that is not compacted and has adequate air and moisture, and by additions of fresh residues they can readily decompose. Soil-applied pesticides can kill many beneficial soil organisms, as will some chemical fertilizers. Anhydrous ammonia and fertilizers with a high chloride content, such as potash, are particularly detrimental to soil organisms. Moderate organic or synthetic fertilizer additions, however, enhance populations of soil organisms in soils with low fertility.

**In soils with low nutrient content, nutrient immobilization inhibits plant growth. In soils with excess nutrients, immobilization conserves nutrients in the bodies of soil organisms, where they are less likely to be lost through leaching and runoff.**

### SOIL HUMUS AND SOIL AGGREGATES

Besides decomposing organic materials, bacteria and fungi in the soil form gels and threads that bind soil particles together. These bound particles are called soil aggregates. Worms, beetles, ants, and other soil organisms move partially decomposed organic matter through the soil or mix it with soil in their gut, coating soil particles with organic gels. As soil particles become

aggregated, soil pore size increases and soils become resistant to compaction. The organic compounds that hold aggregates together also increase the ability of soils to absorb and hold water and nutrients.

As soil organisms decompose manure and plant residues, they release carbon dioxide and produce waste materials, which are further decomposed by other soil organisms. Because carbon is lost to respiration at each stage of this decomposition process, the remaining material increases in relative nitrogen content. The remaining material also increases in chemical complexity and requires increasingly specialized species of decomposers. Efficient decomposition of organic matter thus requires a diversity of soil organisms. Humus is the final, stable product of decomposition, formed when organic matter can be broken down by soil organisms only slowly or with difficulty. Humus-coated soil particles form aggregates that are soft, crumbly, and somewhat greasy-feeling when rubbed together.

### PREVENTING ORGANIC MATTER LOSSES

Perennial plant cover in pastures not only provides organic matter inputs, it also protects against losses of organic matter through erosion. Soil coverage by forages and residues protects the soil from raindrop impact while dense root systems of forages hold the soil against erosion while enhancing water infiltration. Fine root hairs also promote soil aggregation. In addition, a

**Table 3. Typical C:N, C:S, and N:S Ratios.**

Typical C:N, C:S, and N:S ratios of plant residues, excreta of ruminant animals, and biomass of soil microorganisms decomposing in grassland soils (based on values for % in dry matter)

	%N	C:N	%S	C:S	N:S
Dead grass	1.8	26.6:1	0.15	320:1	12:1
Dead clover	2.7	17.7:1	0.18	270:1	15:1
Grass roots	1.4	35:1	0.15	330:1	9:1
Clover roots	3.8	13.2:1	0.35	140:1	10:1
Cattle feces	2.4	20:1	0.30	160:1	8:1
Cattle urine	11.0	3.9:1	0.65	66:1	17:1
Bacteria	15.0	3.3:1	1.1	45:1	14:1
Fungi	3.4	12.9:1	0.4	110:1	8.5:1

From Whitehead, 2000 (reference #11)

dense forage cover shades and cools the soil. High temperatures promote mineralization and loss of organic matter, while cooler temperatures promote the continued storage of this material within the plant residues and the bodies of soil organisms.

#### Table 4. Pasture Management Practices for Efficient Carbon Cycling.

##### Ensure forage and residue coverage and manure deposition across the entire pasture

- Use practices that encourage animal movement throughout the pasture and discourage congregation in feeding and lounging areas

##### Promote healthy forage growth and recovery following grazing

- Use a variety of forages with a diversity of leaf types and orientations
- Use a combination of cool- and warm-season forages with a diversity of shoot and root growth characteristics
- Conserve sufficient forage leaf area for efficient plant regrowth by monitoring pastures and moving grazing animals to another pasture in a timely manner
- Maintain soil tilth for healthy root growth and nutrient uptake

##### Encourage organic matter decomposition by soil organisms

- Use management practices that minimize soil compaction and soil erosion
- Minimize tillage and other cultivation practices
- Maintain a diversity of forage species to provide a variety of food sources and habitats for a diversity of soil organisms
- Avoid the use of soil-applied pesticides and concentrated fertilizers that may kill or inhibit the growth of soil organisms

##### Encourage soil humus and aggregate formation

- Include forages with fine, branching root systems to promote aggregate formation
- Maintain organic matter inputs into the soil to encourage the growth of soil organisms
- Maintain coverage of forages and plant residues over the entire paddock to provide organic matter and discourage its rapid degradation

---

## NITROGEN CYCLE

---

Nitrogen is a primary plant nutrient and a major component of the atmosphere. In a pasture ecosystem, almost all nitrogen is organically bound. Of this, only about 3% exists as part of a living plant, animal, or microbe, while the remainder is a component of decomposed organic matter or humus. A very small percentage of the total nitrogen (less than 0.01%) exists as plant-available nitrogen in the form of ammonium or nitrate (12).

Nitrogen becomes available for the growth of crop plants and soil organisms through nitrogen fixation, nitrogen fertilizer applications, the

return of manure to the land, and through the mineralization of organic matter in the soil. Nitrogen fixation occurs mainly in the roots of legumes that form a symbiotic association with a type of bacteria called *rhizobia*. Some free-living bacteria, particularly cyanobacteria (“blue-green algae”), are also able to transform atmospheric nitrogen into a form available for plant growth. Fertilizer factories use a combination of high pressure and high heat to combine atmospheric nitrogen and hydrogen into nitrogen fertilizers. Animals deposit organically-bound nitrogen in feces and urine. Well-managed pastures accu-

**Figure 5. Nitrogen Cycle.**

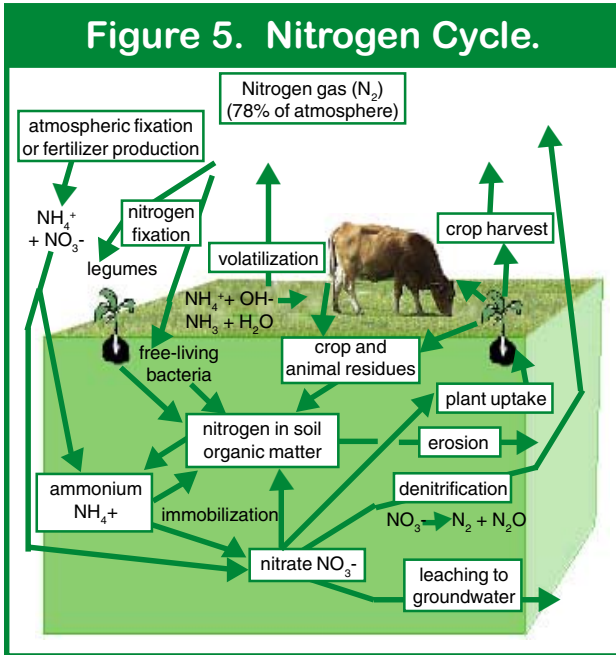

**The Nitrogen Cycle.** Nitrogen enters the cycle when atmospheric nitrogen is fixed by bacteria. Nitrogen in the ammonical form is transformed into nitrite and nitrate by bacteria. Plants can use either ammonia or nitrate for growth. Nitrogen in plant cells can be consumed by animals and returned to the soil as feces or urine. When plants die, soil organisms decompose nitrogen in plant cells and release it as ammonia. Nitrate nitrogen can be lost through the physical process of leaching or through the microbially-mediated process of denitrification. Nitrogen in the ammonical form can be lost to the atmosphere in the chemical process of volatilization.

mulate stores of organic matter in the soil and in plant residues. Decomposition and mineralization of nutrients in these materials can provide significant amounts of nitrogen to plants and other organisms in the pasture system.

Plants use nitrogen for the formation of proteins and genetic material. Grazing animals that consume these plants use some of the nitrogen for their own growth and reproduction; the remainder is returned to the earth as urine or manure. Soil organisms decompose manure, plant residues, dead animals, and microorganisms, transforming nitrogen-containing compounds in their bodies into forms that are available for use by plants.

Nitrogen is often lacking in pasture systems since forage requirements for this nutrient are high and because it is easily lost to the environment. Nitrogen is lost from pasture systems through microbiological, chemical, and physical processes. Dry followed by wet weather provides optimal conditions for bacteria to transform nitrogen from plant-available forms into atmospheric nitrogen through *denitrification*. Chemical processes also transform plant-available nitrogen into atmospheric nitrogen through *volatilization*. In pastures, this often occurs after manure or nitrogen fertilizers are applied to the soil surface, especially during warm weather. Physical processes are involved in the downward movement of nitrogen through the soil profile during *leaching*.

## NITROGEN FIXATION

Plants in the legume family, including alfalfa, clover, lupines, lespedeza, and soybeans, form a relationship with a specialized group of bacteria called *rhizobia*. These bacteria have the ability to fix or transform atmospheric nitrogen into a form of nitrogen plants can use for their growth. Rhizobia form little balls or nodules on the roots of legumes. If these balls are white or pinkish on the inside, they are actively fixing nitrogen. Nodules that are grey or black inside are dead or no longer active. Legume seeds should be dusted with inoculum (a liquid or powder containing the appropriate type of rhizobia) prior to planting to ensure that the plant develops many nodules and has maximal ability to fix nitrogen. Other microorganisms that live in the soil are also able to fix and provide nitrogen to plants.

**Table 5. Nitrogen Fixation by Legumes.**

	#N/acre/ year
Alfalfa -----	150-350
White clover -----	112-190
Hairy vetch -----	110-168
Red clover -----	60-200
Soybeans -----	35-150
Annual lespedeza -----	50-193
Birdsfoot trefoil -----	30-130

From Joost, 1996 (Reference # 13)



Legumes require higher amounts of phosphorus, sulfur, boron, and molybdenum than non-legumes to form nodules and fix nitrogen. If these nutrients are not available in sufficient amounts, nitrogen fixation will be suppressed. When nitrogen levels in the soil are high due to applications of manure or nitrogen fertilizers, nitrogen fixation by legumes decreases because nitrogen fixation requires more energy than does root uptake of soluble soil nitrogen. Nitrogen fixed by legumes and rhizobia is available primarily to the legumes while they are growing. When pasture legume nodules, root hairs, and aboveground plant material dies and decomposes, nitrogen in this material can become available to pasture grasses (14).

However, while legumes are still growing, mycorrhizal fungi can form a bridge between the root hairs of legumes and nearby grasses. This bridge facilitates the transport of fixed nitrogen from legumes to linked grasses. Depending on

**Legumes can transfer up to 40% of their fixed nitrogen to grasses during the growing season.**

the nitrogen content of the soil and the mix of legumes and grasses in a pasture, legumes can transfer between 20 and 40% of their fixed nitrogen

to grasses during the growing season (15). A pasture composed of at least 20 to 45% legumes (dry matter basis) can meet and sustain the nitrogen needs of the other forage plants in the pasture (16).

Grazing management affects nitrogen fixation through the removal of herbage, deposition of urine and manure, and induced changes in moisture and temperature conditions in the soil. Removal of legume leaf area decreases nitrogen fixation by decreasing photosynthesis and plant competitiveness with grasses. Urine deposition decreases nitrogen fixation by adjacent plants since it creates an area of high soluble-nitrogen availability. Increased moisture in compacted soils or increased temperature in bare soils will also decrease nitrogen fixation since rhizobia are sensitive to wet and hot conditions.

### NITROGEN MINERALIZATION

Decomposition of manure, plant residues, or soil organic matter by organisms in the soil re-

sults in the formation of ammonia. Protozoa, amoebas, and nematodes are prolific nitrogen mineralizers, cycling 14 times their biomass each year. While bacteria only cycle 0.6 times their biomass, because of their large numbers in soil they produce a greater overall contribution to the pool of mineralized nitrogen (17). Plants can use ammonical nitrogen for their growth, but under aerobic conditions two types of bacteria usually work together to rapidly transform ammonia first into nitrite and then into nitrate before it is used by plants.

Mineralization is a very important source of nitrogen in most grasslands. As discussed above, for efficient decomposition (and release of nitrogen), residues must contain a carbon-to-nitrogen ratio that is in balance with the nutrient needs of the decomposer organisms. If the nitrogen content of residues is insufficient, soil organisms will extract nitrogen from the soil solution to satisfy their nutrient needs.

### NITROGEN LOSSES TO THE ATMOSPHERE

Under wet or anaerobic conditions, bacteria transform nitrate nitrogen into atmospheric nitrogen. This process, called denitrification, reduces the availability of nitrogen for plant use. Denitrification occurs when dry soil containing nitrate becomes wet or flooded and at the edges of streams or wetlands where dry soils are adjacent to wet soils.

Volatilization is the transformation of ammonia into atmospheric nitrogen. This chemical process occurs when temperatures are high and ammonia is exposed to the air. Incorporation of manure or ammonical fertilizer into the soil decreases the potential for volatilization. In general, 5 to 25% of the nitrogen in urine is volatilized from pastures (11). A thick forage cover and rapid manure decomposition can reduce volatilization from manure.

### NITROGEN LEACHING

Soil particles and humus are unable to hold nitrate nitrogen very tightly. Water from rainfall or snowmelt readily leaches soil nitrate downward through the profile, putting it out of reach of plant roots or moving it into the groundwater. Leaching losses are greatest when the water table is high, the soil sandy or porous, or when rainfall or snowmelt is severe. In pastures, probably the most important source of nitrate leaching is from

urine patches (18). Cattle urine typically leaches to a depth of 16 inches, while sheep urine leaches only six inches into the ground (19). Leaching may also be associated with the death of legume nodules during dry conditions (20).

Methods for reducing nitrate leaching include maintaining an actively growing plant cover over the soil surface, coordinating nitrogen applications with the period of early plant growth, not applying excess nitrogen to soils, and encouraging animal movement and distribution of manure across paddocks. Actively growing plant roots take up nitrate from the soil and prevent it from leaching. If the amount of nitrogen applied to the soil is in excess of what plants need or is applied when plants are not actively growing, nitrate not held by plants can leach through the soil. Spring additions of nitrogen to well-managed pastures can cause excessive plant growth and increase the potential for leaching. This is because significant amounts of nitrogen are also being mineralized from soil organic matter as warmer temperatures increase the activity of soil organisms.

Nitrate levels in excess of 10 ppm in drinking water can cause health problems for human infants, infant chickens and pigs, and both infant and adult sheep, cattle, and horses (21). Pasture forages can also accumulate nitrate levels high enough to cause health problems. Conditions conducive for nitrate accumulation by plants include acid soils; low molybdenum, sulfur, and phosphorus content; soil temperatures lower than 55°F; and good soil aeration (22).

Nitrate poisoning is called methemoglobinemia, commonly known as “blue baby syndrome” when seen in human infants. In this syndrome, nitrate binds to hemoglobin in the blood, reducing the blood’s ability to carry oxygen through the body. Symptoms in human infants and young animals include difficulty breathing. Pregnant animals that recover may abort within a few days. Personnel from the Department of Health can test wells to determine whether nitrate levels are dangerously high.

**Table 6. Estimated Nitrogen Balance (pounds/acre) for Two Grassland Management Systems.**

	Moderately managed grass-clover	Extensively grazed grass
<b>Inputs</b>		
Nitrogen fixation	134	9
Atmospheric deposition	34	19
Fertilizer	0	0
Supplemental feed	0	0
<b>Recycled nutrients</b>		
Uptake by herbage	270	67
Herbage consumption by animals	180	34
Dead herbage to soil	90	34
Dead roots to soil	56	34
Manure to soil	134	28
<b>Outputs</b>		
Animal weight gain	28	4
Leaching/runoff/erosion	56	6
Volatilization	17	3
Denitrification	22	2
<b>Gain to soil</b>	<b>56</b>	<b>13</b>

From Whitehead, 2000 (Reference # 11)

**Table 7. Pasture Management Practices for Efficient Nitrogen Cycling.**

**Ensure effective nitrogen fixation by legumes**

- Ensure that phosphorus, sulfur, boron, and molybdenum in the soil are sufficient for effective nitrogen fixation
- Apply inoculum to legume seeds when sowing new pastures to ensure nodulation of legume roots
- Ensure that legumes represent at least 30% of the forage cover
- Maintain stable or increasing ratios of legumes to grasses and other non-legumes in pastures over time
- Establish forages so that legumes and grasses grow close to one another to allow for the transfer of nitrogen from legumes to grasses

**Encourage nitrogen mineralization by soil organisms**

- Use management practices that minimize soil compaction and soil erosion
- Minimize tillage and other cultivation practices
- Maintain a diversity of forage species to provide a variety of food sources and habitats for a diversity of soil organisms
- Use grazing management practices that encourage productive forage growth and that return and maintain residues within paddocks
- Avoid application of sawdust, straw, or other high-carbon materials unless these materials are mixed with manure or composted prior to application
- Avoid the use of soil-applied pesticides and concentrated fertilizers that may kill or inhibit the growth of soil organisms

**Avoid nitrogen losses**

- Minimize nitrogen volatilization by avoiding surface application of manure, especially when the temperature is high or there is minimal forage cover over the soil
- Minimize nitrogen leaching by not applying nitrogen fertilizer or manure when soil is wet or just prior to rainstorms and by encouraging animal movement and distribution of urine spots across paddocks
- Minimize nitrogen leaching by not applying nitrogen fertilizer or manure to sandy soils except during the growing season
- Rely on mineralization of organic residues to supply most or all of your forage nitrogen needs in the spring. Minimize the potential for nitrogen leaching by limiting spring applications of nitrogen
- Minimize nitrogen losses caused by erosion by using management practices that maintain a complete cover of forages and residues over the pasture surface

**Ensure effective use of nitrogen inputs**

- Use management practices that encourage the even distribution of manure and urine across paddocks
- Rely on soil tests and other nutrient management practices when applying fertilizers and manure to pastures

## NITROGEN LOSS THROUGH RUNOFF AND EROSION

Runoff and erosion caused by rainwater or snowmelt can transport nitrogen on the soil surface. Erosion removes soil particles and organic matter containing nitrogen; runoff transports dissolved ammonia and nitrate. Incorporation of manure and fertilizers into the soil reduces the exposure of these nitrogen sources to rainfall or snowmelt, thus reducing the potential for erosion. In pasture systems, however, incorporation is usually impractical and can increase the potential for erosion. Instead, a complete cover

of forages and plant residues should be maintained over the soil surface to minimize raindrop impact on the soil, enhance water infiltration, help trap sediments and manure particles, and reduce the potential for runoff and erosion. A healthy and diverse population of soil organisms, including earthworms and dung beetles that rapidly incorporate manure nitrogen into the soil and into their cells, can further reduce the risk of nitrogen runoff from manure. Since increased water infiltration decreases the potential for runoff but increases the potential for leaching, risks of nitrate losses from runoff need to be balanced against leaching risks.

## PHOSPHORUS CYCLE

Like nitrogen, phosphorus is a primary plant nutrient. Unlike nitrogen, phosphorus is not part of the atmosphere. Instead, it is found in rocks, minerals, and organic matter in the soil. The mineral forms of phosphorus include apatite (which may be in a carbonate, hydroxide, fluoride, or chloride form) and iron or aluminum phosphates. These minerals are usually associated with basalt and shale rocks. Chemical reactions and microbial activity affect the availability of phosphorus for plant uptake. Under acid conditions, phosphorus is held tightly by aluminum and iron in soil minerals. Under alkaline conditions, phosphorus is held tightly by soil calcium.

Plants use phosphorus for energy transfer and reproduction. Legumes require phosphorus for effective nitrogen fixation. Animals consume phosphorus when they eat forages. Phosphorus not used for animal growth is returned to the soil in manure. Following decomposition by soil organisms, phosphorus again becomes available for plant uptake.

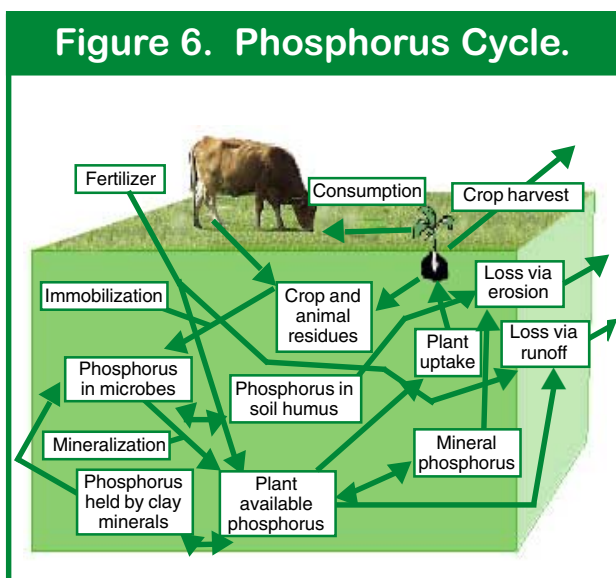

*The Phosphorus Cycle is affected by microbial and chemical transformations. Soil organisms mineralize or release phosphorus from organic matter. Phosphorus is chemically bound to iron and aluminum in acid soils, and to calcium in alkaline soils. Soil-bound phosphorus can be lost through erosion, while runoff waters can transport soluble phosphorus found at the soil surface.*

## MYCORRHIZAE

Mycorrhizal fungi attach to plant roots and form thin threads that grow through the soil and wrap around soil particles. These thin threads increase the ability of plants to obtain phosphorus and water from soils. Mycorrhizae are especially important in acid and sandy soils where phosphorus is either chemically bound or has limited availability. Besides transferring phosphorus and water from the soil solution to plant roots, mycorrhizae also facilitate the transfer of nitrogen from legumes to grasses. Well aerated and porous soils, and soil organic matter, favor mycorrhizal growth.

### SOIL CHEMISTRY AND PHOSPHORUS AVAILABILITY

Phosphorus is tightly bound chemically in highly weathered acid soils that contain high concentrations of iron and aluminum. Active calcium in neutral to alkaline soils also forms tight bonds with phosphorus. Liming acid soils and applying organic matter to either acid or alkaline soils can increase phosphorus availability. In most grasslands, the highest concentration of phosphorus is in the surface soils associated with decomposing manure and plant residues.

### PHOSPHORUS LOSS THROUGH RUNOFF AND EROSION

Unlike nitrogen, phosphorus is held by soil particles. It is not subject to leaching unless soil levels are excessive. However, phosphorus can move through cracks and channels in the soil to artificial drainage systems, which can transport it to outlets near lakes and streams. Depending on the soil type and the amount of phosphorus already in the soil, phosphorus added as fertil-



izer or manure may be readily lost from fields and transported to rivers and streams through runoff and erosion. The potential for phosphorus loss through runoff or erosion is greatest when rainfall or snowmelt occurs within a few days following surface applications of manure or phosphorus fertilizers.

Continual manure additions increase the potential for phosphorus loss from the soil and the contamination of lakes and streams. This is especially true if off-farm manure sources are used to meet crop or forage nutrient needs for nitrogen. The ratio of nitrogen to phosphate in swine or poultry manure is approximately 1 to 1, while the ratio of nitrogen to phosphate taken up by forage grasses is between 2.5 to 1 and 3.8 to 1. Thus, manure applied for nitrogen requirements will provide 2.5 to 3.8 times the amount of phosphorus needed by plants (23). While much of this phosphorus will be bound by chemical bonds in the soil and in the microbial biomass, continual additions will exceed the ability of the soil to store excess phosphorus, and the amount of soluble phosphorus (the form available for loss by runoff) will increase. To decrease the potential for phosphorus runoff from barnyard manure or poultry litter, alum or aluminum oxide can be added to bind phosphorus in the manure (24).

Supplemental feeds are another source of phosphorus inputs to grazing systems, especially for dairy herds. Feeds high in phosphorus increase the amount of phosphorus deposited on pastures as manure. To prevent build up of excess phosphorus in the soil, minimize feeding of unneeded supplements, conduct regular soil tests on each paddock, and increase nutrient removals from excessively fertile paddocks through haying.

Phosphorus runoff from farming operations can promote unwanted growth of algae in lakes and slow-moving streams. Regulations and nutrient-management guidelines are being developed to decrease the potential for phosphorus movement from farms and thus reduce risks of lake eutrophication. Land and animal management guidelines, called “phosphorus indices,” are being developed across the U.S. to provide farmers with guidelines for reducing “non-point” phosphorus pollution from farms (25). These guidelines identify risk factors for phosphorus transport from fields to water bodies based on the concentration of phosphorus in the

**Phosphorus index guidelines consider:**

- the amount of phosphorus in the soil
- manure and fertilizer application rates, methods, and timing
- runoff and erosion potential
- distance from a water body

soil, timing and method of fertilizer and manure applications, potential for runoff and erosion, and distance of the field from a water body (26). Although the total amount of phosphorus lost from fields is greatest during heavy rainstorms, snowmelts, and other high-runoff events, relatively small amounts of phosphorus running off from fields into streams at low water level in summer pose a higher risk for eutrophication. This is because phosphorus is more concentrated in these smaller flows of water (27). Conditions for concentrated flows of phosphorus into low-flow

streams include location near streams of barnyards or other holding areas without runoff containment or filtering systems, extensive grazing of animals near streams without riparian buffers, and unlimited animal access to streams.



**Table 8. Pasture Management Practices for Efficient Phosphorus Cycling.**

**Encourage phosphorus mineralization by soil organisms**

- Use management practices that minimize soil compaction and soil erosion
- Minimize use of tillage and other cultivation practices
- Maintain a diversity of forage species to provide a variety of food sources and habitats for a diversity of soil organisms
- Avoid application of sawdust, straw, or other high-carbon materials unless these materials are mixed with manure or composted prior to application
- Avoid the use of soil-applied pesticides and concentrated fertilizers that may kill or inhibit the growth of soil organisms

**Avoid phosphorus losses**

- Minimize phosphorus losses caused by erosion by using management practices that maintain a complete cover of forages and residues over the pasture surface
- Minimize phosphorus losses caused by runoff by not surface-applying fertilizer or manure to soil that is saturated, snow-covered, or frozen
- Avoid extensive grazing of animals in or near streams especially when land is wet or saturated or when streams are at low flow

**Ensure effective use of phosphorus inputs**

- Use management practices that encourage the even distribution of manure and urine across paddocks
- Rely on soil tests, phosphorus index guidelines, and other nutrient management practices when applying fertilizers and manure to pastures

---

## SECONDARY NUTRIENTS

---

Potassium and the secondary nutrients, calcium, magnesium, and sulfur, play a critical role in plant growth and animal production. Potassium, calcium, and magnesium are components of clay minerals. The soil parent-material primarily influences the availability of these plant nutrients. For example, soils derived from granite contain, on the average, nine times more potassium than soils derived from basalt, while soils derived from limestone have half the amount. Conversely, soils derived from limestone have, on the average, four times more calcium than soils derived from basalt and thirty times more than soils derived from granite (11).

### POTASSIUM

Potassium, like all plant nutrients, is recycled through plant uptake, animal consumption, and manure deposition. The majority of potassium is found in urine. Potassium levels can become excessive in fields that have received repeated high applications of manure. Application of fertilizer nitrogen increases the potassium uptake by grasses if the soil has an adequate supply of potassium. Consumption of forages that contain more than 2% potassium can cause problems in breeding dairy cattle and in their recovery following freshening (28). High potassium levels, especially in lush spring forage, can cause nutrient imbalance resulting in grass tetany.

### CALCIUM AND MAGNESIUM

Calcium and magnesium are components of liming materials used to increase soil pH and reduce soil acidity. However, the use of lime can also be important for increasing the amount of calcium in the soil or managing the balance between calcium and magnesium. Increasing the calcium concentration may enhance biological activity in the soil (29). Managing this balance is especially important for decreasing the occurrence of grass tetany, a nutritional disorder of ruminants caused by low levels of magnesium in the diet. Magnesium may be present in the soil in sufficient amounts for plant growth, but its concentration may be out of balance with the nutrient needs of plants and animals. When calcium and potassium have a high concentration

**Phosphorus fertilization of tall fescue decreased the incidence of grass tetany in cattle since it stimulated grass growth and increased the availability of magnesium during cool wet spring conditions.**

in the soil compared to magnesium, they will limit the ability of plants to take up magnesium. Under these conditions, the magnesium concentration needs to be increased relative to calcium. Dolomite lime, which contains magnesium carbonate, can be used to both lime soils and increase the availability of magnesium. Phosphorus fertilization of tall fescue in Missouri was also shown to increase the availability of magnesium sufficiently to decrease the incidence of grass tetany in cattle (30). This probably resulted from the stimulation of grass growth during cool wet spring conditions that are conducive to the occurrence of grass tetany.

### SULFUR

Sulfur increases the protein content of pasture grasses and increases forage digestibility and effectiveness of nitrogen use (31). In nature, sulfur is contained in igneous rocks, such as granite and basalt, and is a component of organic matter. In areas downwind from large industrial and urban centers, sulfur contributions from the atmosphere in the form of acid rain can be considerable. Fertilizer applications of nitrogen as ammonium sulfate or as sulfur-coated urea also contribute to sulfur concentration in soils. However, pasture needs for sulfur fertilization will increase as environmental controls for acid rain improve, as other sources of nitrogen fertilizer are used, and as forage production increases.

Microbial processes affect sulfur availability. As with nitrogen, the sulfur content of organic matter determines whether nutrients will be mineralized or immobilized. Also as with nitrogen, the sulfur content of grasses decreases as they become older and less succulent. Thus, soil organisms will decompose younger plants more rapidly and thereby release nutrients while they will decompose older plant material more slowly

and may immobilize soil nutrients in the process of decomposition.

Chemical and biological processes are involved in sulfur transformations. In dry soils that become wet or waterlogged, chemical processes transform sulfur from the sulfate to sulfide form. If these wet soils dry out or are drained, bacteria transform sulfide to sulfate. Like nitrate, sulfate is not readily absorbed by soil minerals, especially in soils with a slightly acid to neutral pH. As a result, sulfate can readily leach through soils that are sandy or highly permeable.



### Table 9. Pasture Management Practices for Efficient Cycling of Potassium, Calcium, Magnesium, and Sulfur.

#### Encourage nutrient mineralization by soil organisms

- Use management practices that minimize soil compaction and soil erosion
- Minimize use of tillage and other cultivation practices
- Maintain a diversity of forage species to provide a variety of food sources and habitats for a diversity of soil organisms
- Avoid the use of soil-applied pesticides and concentrated fertilizers that may kill or inhibit the growth of soil organisms
- Encourage animal movement across paddocks for even distribution of manure nutrients

#### Avoid nutrient losses

- Minimize sulfur losses by using management practices that decrease the potential for leaching
- Minimize nutrient losses caused by erosion by using management practices that maintain a complete cover of forages and residues over the pasture surface

#### Maintain nutrient balances in the pasture

- Ensure magnesium availability to minimize the potential for grass tetany. This can be done by balancing the availability of magnesium with the availability of other soil cations, particularly potassium and calcium. Phosphorus fertilization of pastures in spring can also enhance magnesium availability
- Guard against a buildup of potassium in pastures by not overapplying manure. High potassium levels can cause reproductive problems, especially in dairy cows



## Chapter 2

# Nutrient Availability in Pastures

---

Nutrient balances and nutrient availability determine the fate of nutrients in pastures. In the simplest of grazing systems, forage crops take up nutrients from the soil; haying and grazing remove forage crops and their associated nutrients; and animal manure deposition returns nutrients to the soil. Continual nutrient removals deplete soil fertility unless fertilizers, whether organic or synthetic, are added to replenish nutrients. Nutrients may be added to pastures by providing animals with feed supplements produced off-farm.

Chemical and biological interactions determine the availability of nutrients for plant use. Both native soil characteristics and land management practices affect these interactions. Phosphorus can be held chemically by iron or aluminum bonds while potassium can be held within soil minerals. Practices that erode topsoil and deplete soil organic matter decrease the ability of soils to hold or retain nutrients. All crop nutrients can be components of plant residues or soil organic matter. The type of organic matter available and the activity of soil organisms determine the rate and amount of nutrients mineralized from these materials. Nutrient availability and balance in forage plants affect the health of grazing animals. Depleted soils produce unhealthy, low-yielding forages and unthrifty animals; excess soil nutrients can be dangerous to animal health and increase the potential for contamination of wells, springs, rivers, and streams.

---

### SOIL PARENT MATERIAL

---

Chemical, physical, geological, and biological processes affect nutrient content and availability in soils. As discussed in the previous chapter, soils derived from basalt and shale provide phosphorus to soils, granite contains high concentrations of potassium, and limestone is a

source of calcium and magnesium. Some clay soils and soils with high percentages of organic matter contain a native store of nutrients in addition to having the capacity to hold nutrients added by manure, crop residues, or fertilizers. Soils formed under temperate prairies or in flood plains have built up fertility through a long history of organic matter deposition and nutrient accumulation. Sandy soils and weathered,

reddish clay soils contain few plant nutrients and have a limited ability to hold added nutrients. Soils formed under desert conditions are often saline, since water evaporating off the soil surface draws water in the soil profile upward. This water carries nutrients and salts, which are deposited on the soil surface when water evaporates. Tropical soils generally have low fertility since they were formed under conditions of high temperatures, high biological activity, and high rainfall that caused rapid organic matter decomposition and nutrient leaching.

---

### SOIL CHEMISTRY

---

Many clay minerals are able to hold onto water and nutrients and make them available for plant growth. The pH, or level of acidity or alkalinity of the soil solution, strongly influences the strength and type of bonds formed between soil minerals and plant nutrients. Soil pH also affects activities of soil organisms involved in the decomposition of organic matter and the dissolution of plant nutrients from soil minerals. Many clay soil particles are able to bind large amounts of nutrients because of their chemical composition and because they are very small and have a large surface area for forming bonds. Unfortunately, this small size also makes clay particles prone to compaction, which can reduce nutrient and water availability. Sandy soils are porous and allow water to enter the soil rapidly.

**Nutrient-depleted soils produce low-yielding forages and unthrifty animals.**

**Excess soil nutrients can be dangerous to animal health and increase the potential for contamination of wells, springs, rivers, and streams.**

But these soils are unable to hold water or nutrients against leaching. Organic matter has a high capacity to hold both nutrients and water. Soil aggregates, formed by plant roots and soil organisms, consist of mineral and organic soil components bound together in soft clumps. Aggregates enhance soil porosity, facilitate root growth, allow for better infiltration and movement of water and nutrients through soil, and help soils resist compaction.

---

## PRIOR MANAGEMENT PRACTICES

---

In pastures, continual removal of nutrients through harvests or heavy grazing without return or addition of nutrients depletes the soil. Land management practices that encourage soil erosion — such as heavy grazing pressure, plowing up and down a slope, or leaving a field bare of vegetation during times of heavy rains or strong winds — also result in depletion of soil fertility. Some pasture management practices involve the use of fire to stimulate growth of native forages (32). Burning readily mineralizes phosphorus, potassium, and other nutrients in surface crop residues. It also volatilizes carbon and nitrogen from residues and releases these nutrients into the atmosphere, thus minimizing the ability of organic matter to accumulate in the soil. Loss of residues also exposes soil to raindrop impact and erosion. Hot uncontrolled fires increase the potential for erosion by degrading natural biological crusts formed by lichens, algae, and other soil organisms, and by promoting the formation of physical crusts formed from melted soil minerals (33, 34). The continual high application of manure, whey, sludge, or other organic waste products to soils can cause nutrients to build up to excessive levels. Pasture management practices that influence soil compaction, soil saturation, the activity of soil organisms, and soil pH affect both soil nutrient content and availability.



*Compacted soils do not allow for normal root growth. This root grew horizontally when it encountered a compacted layer.*

---

## SOIL COMPACTION

---

Animal movement compacts soil pores, especially when soils are wet or saturated. Continual trampling and foraging, especially in congregation areas and laneways, also depletes plant growth and produces bare spots.

**Soil compaction increases as soil moisture, animal weight, animal numbers, and the length of stay in the paddock increase.**

**Resistance to compaction increases as forage establishment and the percentage of plants with fibrous roots increase.**

Soil compaction reduces nutrient availability for plant uptake by blocking nutrient transport to roots and restricting root growth through the soil profile. Treading and compaction can substantially reduce forage yields. One study showed that the equivalent of 12 sheep treading on mixed ryegrass, white clover, and red clover pasture reduced yields by 25% on dry soil, 30% on moist soil, and 40% on wet soil compared to no treading. On wet soils, root growth was reduced 23% (35).

Compaction also decreases the rate of organic matter decomposition by limiting the access soil organisms have to air, water, or nutrients. In addition, compacted soils limit water infiltration and increase the potential for water runoff and soil erosion. In Arkansas, observers of overgrazed pastures found that manure piles on or near bare, compacted laneways were more readily washed away by runoff than were manure piles in more vegetated areas of the pasture (24).

The potential for animals to cause soil compaction increases with soil moisture, the weight of the animal, the number of animals in the paddock, and the amount of time animals stay in the paddock. The potential for a

paddock to resist compaction depends on the duration of forage establishment and the type of forage root system. Established forages with strong and prolific root growth in the top six to 10 inches of the soil profile are able to withstand treading by grazing animals. Grasses with extensive fibrous root systems, such as bermuda grass, are able to withstand trampling better than grasses like orchardgrass that have non-branching roots or legumes like white clover that have taproots (36). Bunch grasses expose more soil to raindrop impact than closely seeded non-bunch grasses or spreading herbaceous plants. However, these grasses enhance water infiltration by creating deep soil pores with their roots (3). Combining bunch grasses with other plant varieties can increase water infiltration while decreasing the potential for soil compaction and water runoff.

The risk of soil compaction can also be reduced by not grazing animals on paddocks that are wet or have poorly-drained soils. Instead, during wet conditions, graze animals on paddocks that have drier soils and are not adjacent to streams, rivers, seeps, or drainage ways. Soils that are poorly drained should be used only in the summer when the climate and the soil are relatively dry.

Compacted soils can recover from the impacts of compaction, but recovery is

slow. Periods of wet weather alternating with periods of dry weather can reduce compaction in some clay soils. Freezing and thawing decreases compaction in soils subjected to cold weather. Taproots are effective in breaking down compacted layers deep in the soil profile while shallow, fibrous roots break up compacted layers near the soil surface (37). Active populations of soil organisms also reduce soil compaction by forming soil aggregates and burrowing into the soil.

## ORGANIC MATTER

### NUTRIENT RELEASE FROM ORGANIC MATTER DECOMPOSITION

Manure and plant residues must be decomposed by soil organisms before nutrients in these materials are available for plant uptake. Soil organisms involved in nutrient decomposition require a balance of nutrients to break down organic matter efficiently. Manure and wasted forages are succulent ma-

**Time required for organic matter decomposition is affected by:**

- the carbon to nitrogen ratio of organic matter
- temperature
- moisture
- pH
- diversity of soil organisms

**Table 10. Effects of 11 Years of Manure Additions on Soil Properties.**

	Manure application rate (tons/acre/year)			
	<u>None</u>	<u>10 tons</u>	<u>20 tons</u>	<u>30 tons</u>
Organic Matter (%)	4.3	4.8	5.2	5.5
CEC (me/100g)	15.8	17.0	17.8	18.9
PH	6.0	6.2	6.3	6.4
Phosphorus (ppm)	6.0	7.0	14.0	17.0
Potassium (ppm)	121.0	159.0	191.0	232.0
Total pore space (%)	44.0	45.0	47.0	50.0

From Magdoff and van Es, 2000 (Reference #1)

terials that have high nitrogen content and a good balance of nutrients for rapid decomposition.

Dried grasses, such as forages that died back over winter or during a drought, or manure mixed with wood bedding, have lower nitrogen contents and require more time for decomposition. In addition, soil organisms may need to extract nitrogen and other nutrients from the soil to balance their diet and obtain nutrients not available in the organic matter they are decomposing. Composting these materials increases the availability of nutrients and decreases the potential for nutrient immobilization when materials are added to the soil. Temperature, moisture, pH, and diversity of soil organisms affect how rapidly organic matter is decomposed in the soil.

Nutrient release from organic matter is slow in the spring when soils are cold and soil organisms are relatively inactive. Many farmers apply phosphorus as a starter fertilizer in the spring to stimulate seedling growth. Even though soil tests may indicate there is sufficient phosphorus in the soil, it may not be readily available from organic matter during cool springs.



### NUTRIENT HOLDING CAPACITY OF ORGANIC MATTER

Besides being a source of nutrients, soil organic matter is critical for holding nutrients against leaching or nutrient runoff. Stabilized organic matter or humus chemically holds positively-charged plant nutrients (cations). The ability of soil particles to hold these plant nutrients is called *cation exchange capacity* or *CEC*. Continual application of organic materials to soils increases soil humus (38) and enhances nutrient availability, nutrient holding capacity, and soil pore space.

### SOIL AGGREGATES

Soil humus is most effective in holding water and nutrients when it is associated with mineral soil particles in the form of soil aggregates.

Soil aggregates are small, soft, water-stable clumps of soil held together by fine plant-root hairs, fungal threads, humus, and microbial gels. Aggregates are also formed through the activities of earth-

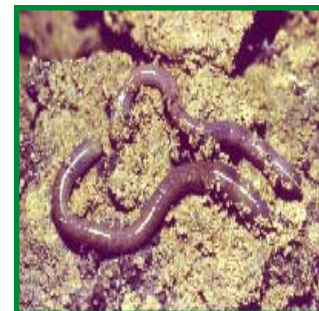

worms. Research has shown that several species of North American earthworms annually consume 4 to 10% of the soil and 10% of the total organic matter in the top 7 inches of soil (39). This simultaneous consumption of organic and mineral matter by earthworms results in casts composed of associations of these two materials. Earthworms, as well as dung beetles, incorporate organic matter into the soil as they burrow.

Besides enhancing the nutrient and water holding capacity, well-aggregated soils facilitate water infiltration, guard against runoff and erosion, protect against drought conditions, and are better able to withstand compaction than less aggregated soils. Since aggregated soils are more granular and less compacted, plant roots grow more freely in them, and air, water, and dissolved plant nutrients are better able to flow through them. These factors increase plant access to soil nutrients.

To enhance aggregation within pasture soils, maintain an optimum amount of forages and residues across paddocks, avoid the formation of bare areas, and minimize soil disturbance. Grazing can degrade soil aggregates by encouraging mineralization of the organic glues that

hold aggregates together. In areas with a good cover of plant residues, animal movement across pastures can enhance aggregate formation by incorporating standing dead plant materials into the soil (40).



---

## SOIL pH

---

Soil mineralogy, long-term climatic conditions, and land-management practices affect soil pH. The acidity or alkalinity of soils affects nutrient availability, nitrogen fixation by legumes, organic matter decomposition by soil organisms, and plant root function. Most plant nutrients are most available for uptake at soil pH of 5.5 to 6.5. Legume persistence in pastures is enhanced by soil pH of 6.5 to 7.0. In low-pH or acid soils, aluminum is toxic to root growth; aluminum and iron bind phosphorus; and calcium is in a form with low solubility. In high-pH or alkaline soils, calcium carbonate binds phosphorus while iron, manganese, and boron become insoluble.

Application of some synthetic nitrogen fertilizers acidifies soils. Soil microorganisms involved in nitrification rapidly transform urea or ammonia into nitrate. This nitrification process releases hydrogen ions into the soil solution, causing acidification, which decreases nutrient availability, thus slowing the growth of plants and soil organisms. Nitrification also occurs in urine patches when soil microorganisms transform urea into nitrate.

Another fertilizer that acidifies the soil is superphosphate. Superphosphate forms a highly acid (pH 1.5) solution when mixed with water. The impact of this acidification is temporary and only near where the fertilizer was applied, but, in this limited area, the highly acid solution can kill rhizobia and other soil microorganisms (9).

The type and diversity of forage species in pastures can alter soil pH. Rangeland plants such as saltbush maintain a neutral soil pH. Grasses and non-legume broadleaf plants tend to increase pH, while legumes tend to decrease it. The impact of plant species on pH depends on the type and amounts of nutrients they absorb. Rangeland plants absorb equal amounts of cation (calcium, potassium, magnesium) and anion (nitrate) nutrients from the soil. Grasses and non-legume broadleaf plants absorb more anions than cations since they use nitrate as their primary source of

nitrogen. Legumes that actively fix nitrogen use very little nitrate; consequently, they reduce soil pH by taking more cations than anions (9). A combination of legumes and non-legumes will tend to stabilize soil pH.

Pasture soils should be tested regularly to determine soil nutrients, soil organic matter, and pH. Based on test results and forage nutrient requirements, management practices can adjust soil pH. Lime and organic matter increase soil pH and decrease soil acidity. Soil organic matter absorbs positive charges, including hydrogen ions that cause soil acidity (41). Lime increases soil pH by displacing acid-forming hydrogen and aluminum bound to the edges of soil particles and replacing them with calcium or magnesium. Limestone that is finely ground is most effective in altering soil pH since it has more surface area to bind to soil particles. All commercial limestone has label requirements that specify its capacity to neutralize soil pH and its reactivity, based on the coarseness or fineness of grind.

“Lime” refers to two types of materials, calcium carbonate and dolomite. Dolomite is a combination of calcium and magnesium carbonate.

Calcium carbonate is recommended for soils low in calcium; where grass tetany or magnesium deficiency is an animal health problem, dolomite limestone should be used. In sandy soils or soils with low to moderate levels of potassium, the calcium or magnesium in lime can displace potassium from the edges of soil particles, reducing its availability. Therefore, these soils should receive both lime and potassium inputs to

prevent nutrient imbalances.

The timing of nutrient additions to fields or pastures determines how effectively plants take up and use nutrients while they are growing and

**Lime soils with calcium carbonate if the soil is low in calcium. Use dolomite limestone if grass tetany or magnesium deficiency is an animal health problem.**

---

## TIMING OF NUTRIENT ADDITIONS

---

setting seed. Different nutrients are important during different stages of plant development. Nitrogen applied to grasses before they begin flowering stimulates tillering, while nitrogen applied during or after flowering stimulates stem and leaf growth (9). However, fall nitrogen applications

for cool-season grasses are more effective and economical than spring applications. In most years, nutrient releases through mineralization are sufficient to stimulate forage growth in the spring. Applications of nitrogen in the late summer and fall allow cool-season grasses to grow and accumulate nutrients until a killing frost. This provides stockpiled growth for winter grazing (42).

Both potassium and phosphorus are important for increasing the nutrient quality of forages, extending stand life, and enhancing the persistence of desirable species in the forage stand (42). Phosphorus is critical for early root growth, for seed production, and for effective nitrogen fixation by legume nodules. Potassium is important during the mid-to-late growing season. It increases the ability of plants to survive winter conditions, by stimulating root growth and reducing water loss through stomata or leaf pores (43). It also is important for legume vigor and for enhancing plant disease resistance (42).

Nutrient uptake by plants corresponds to their growth cycle. Warm-season forages exhibit maximum growth during the summer, whereas cool-season forages exhibit maximum growth during the spring and early fall (32). Pastures containing a diverse combination of forages will use nutrients more evenly across the growing season while less-diverse pastures will show spikes in nutrient uptake requirements.

Legumes provide nitrogen to the pasture system through their relationship with the nitrogen-fixing bacteria, rhizobia. If nitrogen levels in the

**Nitrogen fertilization depresses fixation by legumes since they require less energy to take up nitrogen from the soil than they need to fix nitrogen.**

soil are low, newly planted legumes require nitrogen fertilization until rhizobia have developed nodules and are able to fix nitrogen. Once they start fixing nitrogen, nitrogen fertilization depresses fixation by legumes since they require less energy to take up nitrogen from the soil than they need to fix nitrogen. Legumes can fix up to 200 pounds of nitrogen per year, most of which becomes available to forage grasses in the following years. Phosphorus is essential for effective

nodule formation and nitrogen fixation. In acid soils, liming may make phosphorus already in the soil more available, thereby decreasing the need for fertilization.

As discussed above, the type of organic material added to the soil, as well as temperature, moisture, pH, and diversity of soil organisms, determines how rapidly soil organisms decompose and release nutrients from organic matter. Synthetic fertilizers are soluble and immediately available for plant uptake. Therefore, these fertilizers should be applied during periods when plants can actually use nutrients for growth. A lag time of two to 21 days may pass after fertilizers are applied before increased forage production is observed.

Organic material releases nutrients over a period of several years. On average, only 25 to 35% of the nitrogen in

manure is mineralized and available for plant use during the year of application. Another 12% is available in the following year, 5% in the second year

**A lag time of two to 21 days may pass after fertilizers are applied before increased forage production is observed.**

following application, and 2% in the third year (44). Manure deposited in pastures causes an increase in forage growth approximately 2 to 3 months after deposition, with positive effects on growth extending for up to two years (11). Alfalfa can supply approximately 120 pounds of nitrogen to crops and forages in the year after it is grown, 80 pounds of nitrogen during the following year, and 10 to 20 pounds in the third year (44). Because of this gradual release of nutrients from organic materials, continual additions of manure or legumes will compound the availability of nutrients over time. Accounting for nutrients available from previous years is critical for developing appropriate applications rates for manure and fertilizers during each growing season. Not accounting for these nutrients can result in unnecessary fertilizer expenses and risks of nutrient losses to the environment.

Nutrients from both organic and synthetic fertilizers can be lost through leaching, runoff, or erosion. The potential for nutrient losses is greatest if these materials are applied in the fall or winter, when plants are not actively growing

or during times when soils are frozen, snow-covered, or saturated. During times of high rainfall, nitrate may leach through the soil since it does not bind to soil particles. Rainfall also facilitates the transport of phosphorus to water bodies in runoff water or through artificial drainage tiles. Rainfall or snowmelt water flowing over bare soil causes soil erosion and the transport of nutrients attached to soil particles.

### **Table 11. Pasture Management Practices for Enhancing Nutrient Availability.**

#### **Ensure plant cover and diversity across pastures**

- Use management practices that maintain a complete cover of forages and residues across pastures
- Combine bunch-grass species with a diversity of forage species, including plants with prostrate growth habit, to provide both good water infiltration and protection against erosion and soil compaction

#### **Grazing management practices during wet weather**

- Use well-drained pastures or a “sacrificial pasture” that is far from waterways or water bodies
- Avoid driving machinery on pastures that are wet or saturated
- Avoid spreading manure or applying fertilizers on soil that is saturated, snow-covered, or frozen

#### **Ensure effective use of nutrient inputs**

- Use management practices that encourage the even distribution of manure and urine across paddocks
- Rely on soil tests and other nutrient management practices when applying fertilizers and manure to pastures
- Account for nutrients available from manure and legume applications during prior years when developing fertilizer or manure application rates for the current year
- Sample the nutrient content of added manure to determine appropriate rates of application
- Choose the appropriate type of limestone to apply for pH adjustment based on calcium and magnesium needs and balances in pastures
- Either avoid the use of fertilizers that decrease soil pH or use lime to neutralize soils acidified by these fertilizers
- Apply nitrogen fertilizer in the fall to enhance the amount of forages stockpiled for winter grazing
- Apply sufficient phosphorus and potassium while limiting additions of nitrogen in order to favor growth of legumes in your pastures

# Chapter 3

## Nutrient Distribution and Movement in Pastures

Farmers and ranchers graze animals using a variety of management methods. In this document, *extensive grazing* refers to the practice of grazing animals continuously or for extended periods of time on a large land area. *Rotational grazing* is a management-intensive system that concentrates animals within a relatively small area (a paddock) for a short period of time — often less than a day for dairy animals. The animals are then moved to another paddock, while the first paddock is allowed to recover and re-grow. Animals are moved according to a flexible schedule based on the herd size, the amount of land available, quality of forages in the paddock, and forage consumption. Grazing managers determine when and how long to graze animals in specific paddocks based on climatic conditions, soil characteristics, land topography, and the distance the paddock is from streams or rivers.

Pasture size, shape, and topography; stocking rate; grazing duration; and time of day all affect how animals graze, lounge, drink water, and use feed or mineral supplements. Also, different animal species vary in their use of nutrients and their herding behavior. These factors, along with soil characteristics, climate, and forage and soil management practices, affect nutrient cycling in pastures, animal growth and productivity, and potential of manure nutrients to contaminate ground or surface water.

### PASTURE NUTRIENT INPUTS AND OUTPUTS

#### NUTRIENT BALANCES

Maintaining a balance between nutrients removed from pastures and nutrients returned to pastures is critical to ensure healthy and productive forage growth, as well as to control nutrient runoff and water-body contamination. Nutrient balances in pastures are determined by subtracting *nutrient removals* in the form of hay harvested, feed consumed, and animals sold, from *nutrient inputs* including feed, fertilizer, and manure.

**Figure 7. Pasture Nutrient Inputs and Outputs.**

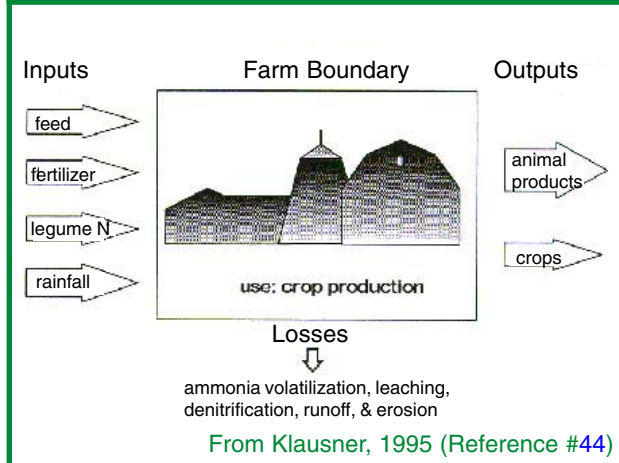

Grazing animals that receive no mineral or feed supplements will recycle between 75 and 85% of forage nutrients consumed. If no fertilizer or outside manure inputs are applied, continual grazing will cause a gradual depletion of plant nutrients. Animals provided feed or mineral supplements also deposit 75 to 85% of the nutrients from these inputs as urine and feces (42). These nutrients represent an input into the pasture system. Nutrient inputs from non-forage feeds can be substantial for dairy and other animal operations that use a high concentration of grain and protein supplements, importing into the pasture approximately 148 lbs. N, 32 lbs. P, and 23 lbs. K per cow per year (42). Winter feeds also form a substantial input into the pasture nutrient budget when animals are fed hay while being kept on pasture.

#### MANURE DEPOSITION AND DISTRIBUTION

A cow typically has 10 defecations per day, with each manure pile covering an area of approximately one square foot (47). They will also urinate between eight and 12 times per day (48). Each urination spot produces a nitrogen application equivalent to 500 to 1,000 lbs./acre while each defecation represents a nitrogen application rate of 200 to 700 lbs./acre (42). An even distribution of nutrients throughout a paddock is required for productive plant and animal growth.



**Table 12. Nutrient Consumption and Excretion by Grazing Animals.**

	Dairy cows	Beef /Sheep
Feed consumption/day	18–33 lbs.	
Nutrients used for growth and reproduction	17% N 26% P	15 -25% N 20% P, 15% K
Nutrients removed from pasture in form of milk and meat	N 84 lbs./cow P 15 lbs./cow K 23 lbs./cow	N 10 lbs./cow-calf P 3 lbs./cow-calf K 1 lbs./cow-calf
Nutrients/ton manure	6–17 lbs.N 3–12 lbs.P <sub>2</sub> O <sub>5</sub> 2-15 lbs. K <sub>2</sub> O	
Nitrogen content of feces	2.0–3.6%	3.4–3.6%
Nitrogen excreted as feces	55 lbs./year	
Nitrogen content of urine	0.42–2.16%	0.30–1.37%
Nitrogen excreted as urine	165 lbs./year	

From Stout, et al. ( 45), Detling ( 46), Russelle ( 17), Wells and Dougherty ( 47) , Haynes and Williams ( 41), Klausner ( 44), Lory and Roberts ( 42)

Unfortunately, grazing animals do not naturally deposit urine and feces evenly across the paddocks where they graze. In one rotational grazing study, urine spots occupied 16.7% of the pasture, while manure spots occupied 18.8%, following 504 grazing days per acre (49). Intensity of grazing rotations affects the distribution of manure coverage in paddocks. Under continuous, extensive grazing practices, 27 years would be needed to obtain one manure pile on every square yard within a paddock; if a two-day rotation were used instead only two years would be needed (42).

Nutrient concentration within pastures results from the tendency of grazing animals to congregate. They tend to leave manure piles or urine spots around food and water sources, on side hills, in depressions, along fence lines, and under shade. Sheep have a greater tendency than cattle to congregate and deposit manure in these areas (50). Prevailing wind direction and exposure to sunlight can also affect animal movement, congregation, and manure deposition (51). Laneways that connect pastures or lead to watering areas are another area of animal congregation and manure deposition. When animals have to walk more than 400 feet from the pas-

ture to water, they deposit between 13 and 22% of their manure on laneways (47, 52).

A study conducted in Iowa showed a buildup of nutrients extending 30 to 60 feet into the pasture around water, shade, mineral supplements, and other areas where cattle congregated (53). Nutrients are concentrated in these congregation areas because animals transport nutrients from areas where they graze. Consequently, they also deplete nutrients from the grazing areas. Grazing practices that encourage foraging and manure distribution across paddocks and discourage congregation in limited areas will improve nutrient balances within pastures.

The time of day when animals congregate in different areas determines the amount and type of nutrients that accumulate in each area. Animals tend to deposit feces in areas where they rest at night or ruminate during the day, while they urinate more in the areas where they graze during the day (47). Nitrogen is present in both feces and urine while phosphorus is primarily deposited as feces, and potassium is found mostly in urine. While most urine is deposited during the day, urine that is deposited at night has a higher nutrient content than urine deposited while grazing (41). As a result of these fac-

**Figure 8.  
3-Paddock System.**

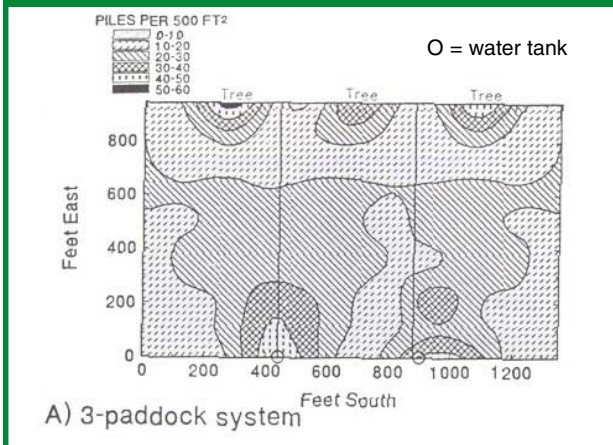

**Figure 9.  
12-Paddock System.**

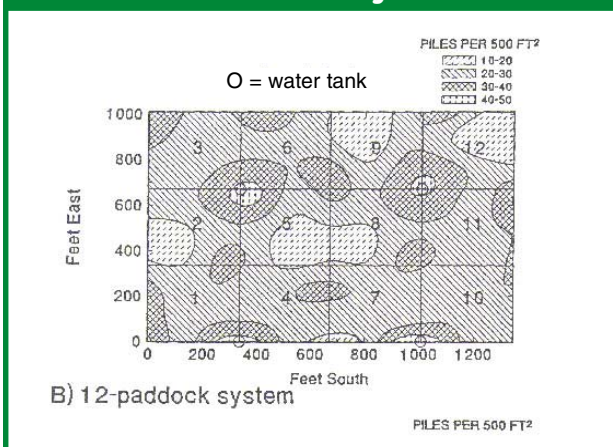

**Figure 10.  
24-Paddock System.**

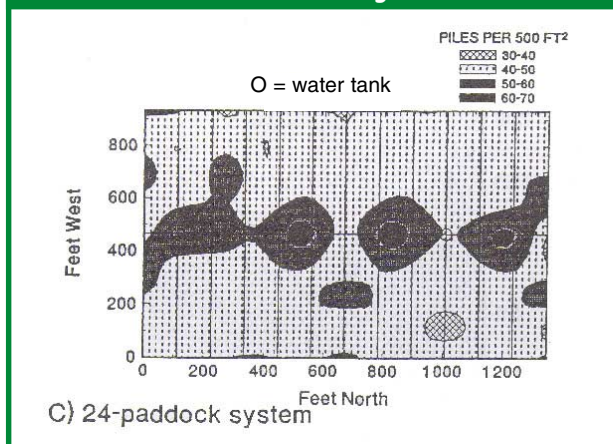

**Manure deposition as affected by paddock size (from Peterson and Gerrish, Reference 52).**

tors, phosphorus will accumulate in resting areas (13) while nitrogen and potassium will accumulate in both resting and grazing areas.

### MINIMIZING ANIMAL CONGREGATION

By working with the normal foraging and herding behavior of grazing animals, distribution of animals across paddocks can be encouraged. In larger paddocks, animals tend to graze and lounge as a herd, while they distribute themselves more evenly across smaller paddocks (41). In larger paddocks, animals visit water, minerals, shade, and fly-control devices as a herd, whereas animals concentrated within small paddocks tend to visit these areas one-by-one. Locating nutrients, shade, and pest-control devices farther apart in the paddock further discourages concentration of animals and manure. If a particular area of a paddock is deficient in nutrients, placement of supplemental feeds in that area can be used to encourage congregation and manure deposition there.

Subdividing depressions, side hills, and shady areas among several paddocks can enhance nutrient distribution across the landscape. Research conducted in Missouri showed that manure nutrients were distributed more evenly across the landscape when a field was managed using 12 or 24 paddocks rather than only three paddocks (54). Animals in the smaller paddocks concentrated around favored areas for less time than did animals in larger paddocks. Since animals tend to graze along the perimeter of fence lines, they distribute nutrients most evenly across paddocks that are small, square, and have water available (55). An efficiently designed paddock allows animals to graze and drink with a minimum amount of time, effort, and trampling of the pasture sod.

### MANURE NUTRIENT AVAILABILITY

While feces contain nitrogen predominantly in the organic form, 60 to 70% of cow-urine nitrogen and 70 to 80% of sheep-urine nitrogen is in the form of urea. Urea and potassium in urine are soluble and therefore immediately available for plant uptake. Phosphorus in feces is predominantly in the organic form and must undergo decomposition before it is available to plants. Soil

organisms will decompose moist, nitrogen-rich manure piles derived from succulent grasses relatively quickly. They will have difficulty breaking down manure derived from hay or older forages that is stiff, dry, and crusty. When a hard crust forms on manure piles during dry weather, both physical breakdown and biological decomposition are inhibited (41). By treading on manure piles as they move around a pasture, animals physically break these piles into smaller pieces that are more easily consumed by soil organisms.

Because nutrients are released slowly from manure, forage plants in the vicinity of manure piles will grow slowly for about two months following manure deposition (41, 42). However, as decomposition of manure piles by soil organisms makes nutrients available for plant use, greater pasture regrowth and forage production occurs in the vicinity of manure and urine compared to other pasture areas (49, 54, 56). Increases in nitrogen availability in areas near manure piles can favor the growth of grasses compared to legumes (9), an impact that can last for up to two years (41).

Animals naturally avoid grazing near dung sites, but will feed closer to manure piles (41) and use forages more efficiently as grazing pressure intensifies. In multispecies grazing systems, sheep do not avoid cattle manure as much as cattle do (57). While both sheep and cattle avoid sheep manure, the pellet form of sheep manure has a large surface area, and thus breaks down more rapidly than cattle manure. Consequently, forages are used more effectively when cattle are combined with sheep.

## PASTURE FERTILIZATION

Manure and fertilizers are applied to pastures to provide nutrients necessary to obtain effective plant growth and animal production. Applications should be based on regular soil testing, the ability of soil to provide and retain nutrients, plant needs, grazing intensity, and nutrient removals through

**Fertilizer and manure applications should be based on regular soil testing, the ability of soil to provide and retain nutrients, plant needs, and grazing intensity.**

haying. Prior to the current concerns over water quality, manure application recommendations were made to meet forage needs for nitrogen. Continued nitrogen-based applications result in a phosphorus build-up in the soil since manure usually contains about the same concentration of phosphorus and nitrogen, while plants only require one-half as much phosphorus as nitrogen. In diverse pastures that contain a combination of grasses and legumes, decreasing or eliminating manure applications can lower phosphorus imbalances while maintaining forage yields. Nitrogen fixation by legumes helps satisfy forage nitrogen requirements while using excess soil phosphorus.

**Figure 11. P Added in Manure/Removed by Crop.**

Applying manure to meet the nitrogen needs of corn (about 200 lbs. N/acre) adds much more phosphorus than corn needs.

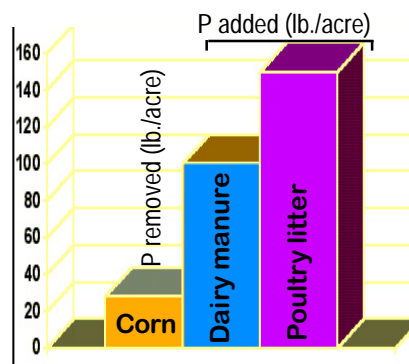

From Sharpley, et al. (Reference 58)

On some farms, manure is applied to soil as a waste product. Instead of being applied according to crop needs, manure is primarily applied according to the need to dispose of manure, the location of fields in relation to the barn, and the accessibility of fields during bad weather. These “waste application” practices present a high potential for nutrient buildup and movement of excess nutrients to ground or surface waters.

To ensure that manure is used effectively as a source of plant nutrients and poses minimal risks to the environment, it should be applied according to a nutrient management plan. Natural Resources Conservation Service or Soil and Water Conservation District personnel, as well

as many commercial crop consultants, are trained in the development of nutrient management plans. Software programs to develop your own nutrient management plan may be available from Cooperative Extension Service educators or Agronomy and Soil Science specialists at land grant universities.

**Table 13. Components of a Comprehensive Nutrient Management Plan.**

**Components of a Comprehensive Nutrient Management Plan**

- Soil tests on all fields or paddocks
- Manure tests
- Load-capacity and rate-of-application of manure spreading equipment
- Timing and method of manure and fertilizer applications
- Prior land management practices including manure applications, legumes used as green manures, fallows, or hay removal
- Assessments of runoff, erosion, and flooding potentials for each field or paddock
- Crops or forages to be produced
- Current pasture management practices, including stocking rates and hay removal

**Format of a nutrient management plan for each paddock or field**

- Soil and manure test results
- Risk factors such as excess nutrient levels, or high runoff, erosion, or flooding potential
- Recommended time, method, and rate for fertilizer and manure applications
- Recommended time for grazing, especially on pastures with moderate to high potentials for runoff, erosion, or flooding
- Management practices to minimize risk factors and maximize nutrient availability to forages

**GRAZING INTENSITY**

**DEFINITION**

Grazing intensity refers to the impact animals have on forage growth and reproduction and on soil and water quality. It is influenced by animal foraging habits, stocking rates, the length of time animals are allowed to graze within a given paddock, and the relation these factors have to soil characteristics and climatic conditions. Continuous high-intensity grazing depletes soil nutrients, decreases the diversity of forage species, inhibits the ability of some forage plants to regrow and reproduce, and increases the potential for nutrient runoff and erosion. Conversely, short-term high-intensity grazing combined with a resting period (as in rotational grazing practices) causes an increase in the diversity of forage spe-

**Short-term high-intensity grazing combined with a resting period (as in rotational grazing practices) causes an increase in the diversity of forage species, enhances the dispersal of forage seeds, and helps conserve nutrient resources within the soil-plant system.**

cies, enhances the dispersal of forage seeds, and helps conserve nutrient resources within the soil-plant system.

**GRAZING BEHAVIOR, PLANT GROWING POINTS, AND PLANT LEAF AREA**

Grazing habits of different animal species have different impacts on forage species composition in pastures. For example, horses graze more closely to the ground than cattle; sheep graze at soil level and can take away the base of grass plants below the area of tiller emergence (59); while cattle tend to graze taller grasses that sheep may reject. Animal grazing behavior, the location of a plant's growing point, and the amount of

leaf area remaining when animals are rotated to another pasture affect the ability of plants to regrow. If grazing animals remove the growing point and substantial leaf area of grasses, new leaf growth must come from buds that have been dormant and the energy for this growth must

come from stored carbohydrates rather than from photosynthesis (60).

Early in the growing season, all grasses have their growing points at or near ground level. Ryegrass, tall fescue, Kentucky bluegrass and many other species of cool-season grasses have growing points that remain at or below ground level throughout most of the growing season. Other, predominantly native, grass species — including smooth broomgrass, timothy, reed canarygrass, switchgrass, and gamagrass — have stems that elongate below the growing point above the soil level (60). As long as the growing point remains intact, the plant is capable of producing new leaves. Grasses with low growing points are able to recover from grazing relatively quickly because the growing point is not disturbed. If the growing point is removed, growth recommences from the emergence of new tillers. Under continuous, intensive grazing practices, warm-season grasses recover more slowly than cool-season grasses, especially during the spring (61). As a result, continuous grazing practices or grazing too early in the season tends to favor the growth of non-native grasses and decrease the diversity of forages in pastures (62).

**Continuous grazing tends to favor the growth of cool-season grasses since grazing animals remove the elevated growing points of native warm-season grasses more readily than they remove the lower growing points of non-native, cool-season grasses.**

For areas with moderate rainfall, leaf area remaining after grazing is more critical for forage recovery than the location of a forage plant's growing point (J. Gerrish, personal communication). Most forbs and legumes, such as alfalfa and red clover, have aerial growing points relatively high up on the plant, which are easily removed by grazing animals. This is not detrimental to plant growth unless a majority of the leaf area or the basal portion of the plant is removed. For optimal recovery, at least 3 to 4 inches of residual leaf area should remain on cool-season grasses while 4 to 8 inches of leaf area should remain for warm-season grasses following grazing (61). Other factors that affect plant regrowth

include treading impact on leaf and root growth, forage composition impact on the ability of plants to intercept sunlight for photosynthesis, and soil conditions (35).

### NUTRIENT UPTAKE

Forage plants that are cut or regrazed frequently during the growing season take up more nutrients than forages that are not cut or grazed. Research conducted in Kansas indicated that cutting pasture forage six times during the growing season resulted in 4.3 times greater nitrogen content and 5.2 times greater phosphorus content in cut forages compared to uncut plots (63). Cutting pastures in the spring when seed heads are forming can also increase the productivity and nutrient uptake of pasture forages (64). Other studies (56, 65) demonstrated that increased grazing intensity resulted in younger, more succulent plants with a higher nitrogen content compared to plants growing in ungrazed areas. The higher nitrogen content was attributed to return of nitrogen to the system through urine and to the availability of nitrogen fixed by legumes. In these studies legumes remained prevalent in the more intensely grazed plots while their populations decreased in the more lightly grazed paddocks (65).

### YIELD

During the first year of intensive grazing, increasing the intensity of cutting or grazing increases the amount of forage produced. Following grazing, photosynthesis is stimulated and plants take up more nutrients. This permits leaf regrowth in broadleaf plants and increased tillering in grasses. Increased leaf area then allows for greater photosynthesis. As photosynthesis and the formation of carbohydrates increase, nutrient uptake by roots and subsequent movement of nutrients from roots to leaves also increase. However, as more energy and nutrients are allocated to leaf production and increased photosynthesis, less energy and nutrients are provided for root growth (63).

**Frequently grazed plots exhibit high biomass production and nutrient uptake during the initial grazing season. But if grazing intensity is too great, forage production will decrease in the following years.**

While frequently mowed or grazed plots exhibit high biomass production and nutrient uptake during the initial grazing season, if the intensity of grazing is too high, forage production will decrease in following years (63, 66). This production decline results from decreased plant ability to take up nutrients because of decreased root growth and depletion of soil nutrients. Severe grazing will also impact plant diversity, since grazing during flowering removes seed heads and flowers, limiting the reseeding of forage plants (64).

**A sufficient resting period allows plants to regrow and produce adequate leaf area for photosynthesis. It also allows plants and soil organisms to reduce soil compaction and increase the availability of nutrients through mineralization.**

Root growth is critical for water and nutrient uptake. Plants can also store food reserves in roots to allow for regrowth during periods of stress. Plants grazed too frequently or cut too short have difficulty producing more leaves because of limited growth and food reserve storage by roots. In one study, plants that were not cut until they reached eight inches tall produced more growth than plants cut every time they reached two inches tall. Similarly, grasses subjected to continuous intensive grazing by sheep produced less vegetation than lightly grazed pastures. In both cases, a longer resting period resulted in better plant growth, since the resting period allowed plants to regrow and produce adequate leaf area for photosynthesis (63). Grass tiller population and pasture production markedly increased in an extensively grazed pasture that was fallowed for one year. This resting period allowed plants and soil organisms to reduce soil compaction and increase the availability of nutrients through mineralization (67).

Cutting grasses short not only depresses plant regrowth, it also increases soil temperature. As soil temperature increases so does nutrient mineralization by soil organisms. While mineralization is necessary to release nutrients from plant and animal residues, if mineralization is too rapid, it can cause a loss of organic matter

(65). Grazing or cutting pastures too short can also expose bare soil to the impact of rainfall, increasing the potential for soil compaction and the loss of topsoil and nutrients through erosion. Nutrient cycling and effective nutrient use by plants depend on pasture management practices that minimize soil compaction, conserve organic matter, and do not hinder plant regrowth following grazing.

**Nutrient cycling and effective nutrient use by plants depend on pasture management practices that minimize soil compaction, conserve organic matter, and do not hinder plant regrowth following grazing.**

The nutrient content of forage plants affects animal feeding habits, the amount of nutrition animals obtain, and the type of manure they produce. Succulent, nutritionally balanced pastures provide good animal productivity and cause animals to deposit moist manure piles (36). Animals feeding on dry, older, or overgrazed forages will obtain limited nutrient value. Manure piles produced from these forages will be stiff because of their high fiber content. Dry, stiff manure piles are difficult for soil organisms to decompose since there is little air within the pile (68). Conversely, animals often deposit very liquid manure as they begin feeding on pastures in the spring after a winter of eating hay. The high moisture content of the pasture forages results in a very wet manure pile that disperses across the soil. Soil organisms are able to decompose manure that has relatively high nitrogen and moisture content more readily than manure that is drier and more carbon-rich.

---

## DIVERSITY AND DENSITY OF PASTURE PLANTS

---

Diverse forage mixtures of both broadleaved plants and grasses use solar energy efficiently. The shape and orientation of plant leaves affect how and when the plant can best conduct photosynthesis. Tall plants and upright grasses cap-

ture light at the extreme angles of sunrise and sunset while horizontal leaves of broadleaf plants use sunlight better at midday. A combination of tall sun-loving plants with shorter shade-tolerant plants allow for the capture of both direct and filtered sunlight. A combination of warm- and cool-season grasses allows for effective photosynthesis throughout the growing season. Warm-season grasses like big bluestem are better able to grow and use solar energy at temperatures between 90 and 100°F, while cool-season grasses like tall fescue grow best between 75 and 90°F (32).

### PERSISTENCE OF PASTURE LEGUMES

Maintaining legumes as part of the forage mix is necessary if nitrogen fixation is to provide most of the nitrogen input to the pasture system. Legumes with a deep taproot and a woody crown, such as alfalfa, red clover, and birdsfoot trefoil, are able to persist in a well-drained pasture because they are able to obtain water and nutrients from deep below the soil surface. They also tolerate drought and cold, and are able to regrow unless their growing points are elevated and exposed to defoliation. Rotational grazing has been shown to increase the proportion of red clover and alfalfa in mixed pastures (69).

White clover has rhizomes rather than a taproot. This growth habit allows it to colonize bare soils (64) by forming additional plants through the growth of stolons.

White clover is competitive with grass at low production densities while legumes with taproots are more competitive at high production densities (70).

The diversity of forage species also affects the persistence of legumes within a pasture. When six to eight forage species were planted

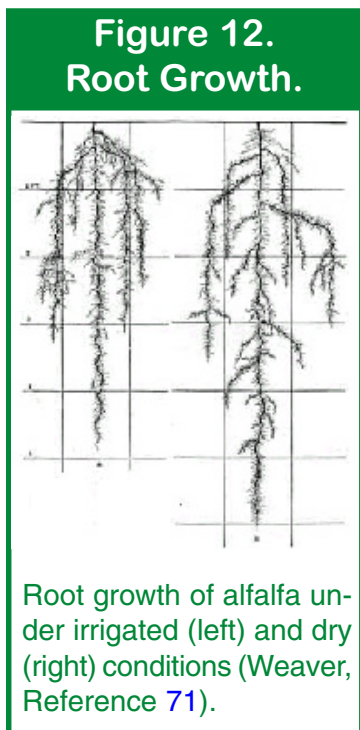

**Timing of grazing affects species composition and diversity in pastures.**

together in a Missouri pasture, pasture plant diversity remained high after three years of grazing. Pastures with a diversity of forage species also maintained a higher

percentage of forage cover during this time than pastures planted to monocultures or simple mixtures of forages (72). Productivity within pastures is more stable when forages provide a diversity of function and structure, such as height, root growth habit, life cycle, and habitat requirements (4).

**Nitrogen transfer between grasses and legumes is greatest when there is a close population balance between these species and they are growing close together.**

Nitrogen fixation is directly related to the ability of legumes to accumulate energy through photosynthesis. Thus, leaf removal decreases nitrogen fixation, and leaf regrowth increases the potential for nitrogen fixation. Legumes not only fix nitrogen for their own needs, but are also able to supply nitrogen to non-nitrogen-fixing forage crops. They primarily supply nitrogen to forage plants following decomposition. Pastures dominated by clover produce around 200 pounds nitrogen per acre per year through nitrogen fixation.

Legumes can also provide nitrogen to companion grass species during the growing season. In New Zealand, perennial ryegrass obtained 6 to 12% of its nitrogen from associated white clover. Alfalfa and birdsfoot trefoil provided up to 75% of the nitrogen used by reed canarygrass in Minnesota. This nitrogen transfer occurs when roots die, nodules detach, or neighboring grasses and legumes become interconnected by their roots or through mycorrhizae. Nitrogen transfer between grasses and legumes is greatest when there is a close population balance between these species and they are growing close together (15). In the first year of legume establishment, nitrogen transfer is relatively low and is derived predominantly from nodule decomposition; it increases in the second year as direct-transfer mechanisms through mycorrhizae become established (14).

## NUTRIENT USE EFFICIENCY

A diverse plant community uses soil nutrients more effectively than a monoculture or simple plant mixtures. Native grasses have a lower requirement for nitrogen and subsequently a lower concentration of nitrogen in their leaf tissue compared to non-native cool-season grasses. As a result, these grasses thrive under low nutrient conditions but they provide lower-quality feed and recycle nutrients more slowly back to the soil system. The low nitrogen content of the plant litter results in slow decomposition, immobilization of nitrogen by organisms involved in decomposition, and a decrease in the nitrogen available for plant uptake.

**Just as a diverse plant canopy covers the entire soil surface, a diversity of root systems occupies the entire soil profile.**

Broadleaf plants require higher nitrogen inputs for productive growth and have higher nitrogen content in their plant tissues than grasses

(73). Due to their high nitrogen content, decomposition of residues from these plants stimulates the mineralization or release of nutrients into the soil solution. Cool-season and warm-season forages grow and take up nutrients at different times of the year. A combination of cool- and warm-season forages ensures a relatively even uptake of nutrients throughout the growing season.

Just as a diverse plant canopy covers the entire soil surface, a diversity of root systems occupies the entire soil profile, from the soil surface down as far as 15 feet. Grasses generally have fine bushy roots. Legumes such as alfalfa or red clover have taproots. Some plants have longer or deeper root systems while other plants have a root system that grows primarily in the surface soil. Pastures that contain plants with a diversity of root systems will be better able to harvest and use nutrients from the soil than a less diverse community. Plants with more shallow roots are effective in recycling nutrients released through the decomposition of thatch and manure on the soil surface, while deep-rooted plants are able to scavenge nutrients that have been leached down through the soil profile.



*Manure is unevenly distributed, concentrated near the fence line*



**Table 14. Enhance Nutrient Balances within the Farm and across Paddocks.**

**Balance nutrient inputs and outputs**

- Replenish nutrients removed by grazing animals
- Recognize that feed supplements, particularly for dairy cows, represent significant nutrient inputs onto farms
- Replace nutrients based on a comprehensive nutrient management plan that takes into account prior manure additions, nitrogen contributions from legumes, and soil tests
- Apply manure based on the phosphorus needs of forages in order to avoid phosphorus build up on pastures; rely on legumes to supply much of the nitrogen needed for forage growth

**Promote even distribution of manure nutrients across paddocks**

- Subdivide pastures to distribute congregation areas among several paddocks
- Keep paddock dimensions as close to square as possible
- Provide animals with water in every paddock; avoid use of laneways to access water
- Locate nutrient supplements, shade, water, and pest-control devices far apart from one another

**Enhance nutrient availability**

- Enhance growth of soil organisms involved in the decomposition of manure by maintaining good soil quality and minimizing use of soil-applied insecticides and high-salt fertilizers
- A combination of cattle and sheep enhances the amount of land available for grazing since sheep graze closer to cattle manure than cattle do and feed on coarser vegetation than cattle will use

**Encourage a diversity of forage species within paddocks**

- Maintain a diversity of forages representing a variety of leaf and root growth habits, life cycles, and habitat preferences
- Rotate pastures while at least 4 inches of the leaf area remains. This allows plants to regrow rapidly and roots to recover
- Maintain a high percentage of legumes in the forage mix by not overgrazing and by minimizing nitrogen fertilizer additions
- Provide paddocks with sufficient rest time to allow forages to regrow

## Chapter 4: The Soil Food Web and Pasture Soil Quality

### DIVERSITY OF THE SOIL FOOD WEB

Soil organisms play a critical role in nutrient cycling. Not only are they responsible for decomposing organic matter, forming soil aggregates, solubilizing mineral nutrients, and adjusting soil pH; they are also responsible for nitrogen fixation, nitrification, phosphorus uptake through mycorrhizae, degradation of soil minerals, and formation of plant hormones. A healthy soil contains millions of or-

**Soil food web refers to the network of dynamic interactions among these organisms as they decompose organic materials and transform nutrients.**

ganisms, ranging from visible insects and earthworms to microscopic bacteria and fungi. An acre of living soil may contain 900 pounds of earthworms, 2400 pounds of fungi, 1500 pounds of bacteria, 133 pounds of protozoa, and 890 pounds of arthropods and algae, as well as small mammals. The term *soil food web* refers to the network of dynamic interactions among these organisms as they decompose organic materials and transform nutrients.

While some of the organisms in this diverse community are plant pests, many more serve as antagonists of plant pests and diseases. Other soil organisms, particularly bacteria, are able to use toxic chemicals, such as pesticides, as a source of food. As they consume these toxic chemicals, they break them down into substances, such as carbon dioxide, water, and atmospheric nitrogen, that are either non-toxic or less-toxic to plants, animals, and humans.

From Killham, 1994 (Reference #74)

**Figure 13. Foodweb of Grassland Soil.**

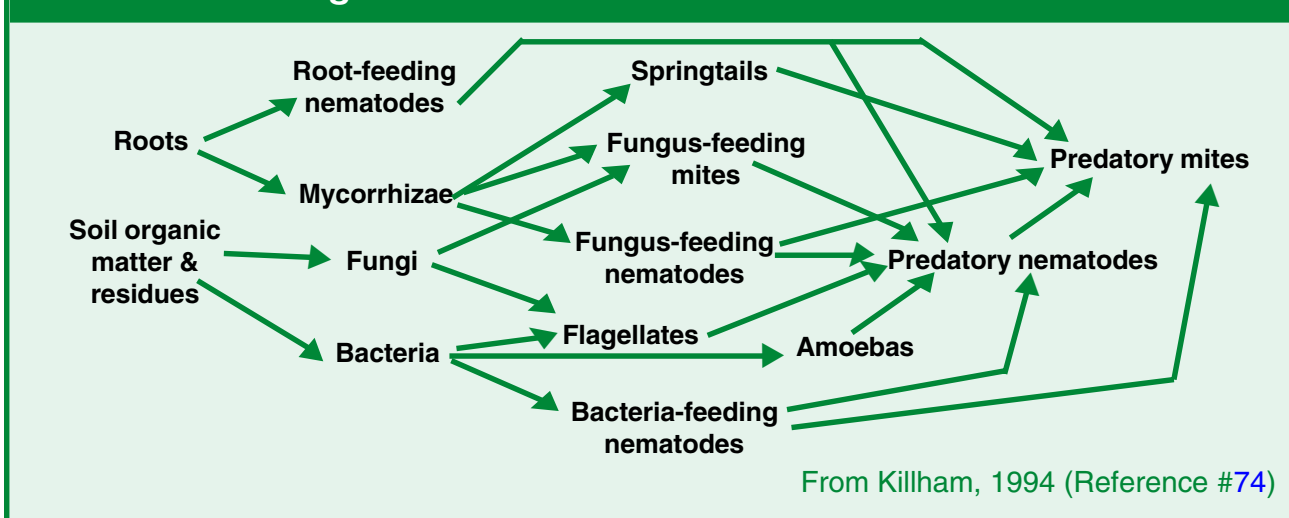

### ORGANIC MATTER DECOMPOSITION

#### SOIL ORGANISMS

Many soil organisms are involved in the decomposition of organic matter. Larger soil organisms, including small mammals, insects, and earthworms, are *primary decomposers*, involved in the initial decomposition and cycling of nutri-

ents. Primary decomposers make greater use of carbon than of nitrogen in their growth and respiration processes. As a result, the feces and casts deposited by them have a lower carbon content and a lower ratio of carbon to nitrogen than the original organic matter. By transforming organic matter into a simpler chemical form as well as physically breaking it down into smaller pieces, primary decomposers make these materials more available to microorganisms or *secondary decom-*

posers for further breakdown. Because the dead bodies of earthworms and insects are high in nitrogen, they are easily decomposed by soil microorganisms (75). Fungi and bacteria are predominant secondary decomposers, but algae, protozoa, amoebas, actinomycetes, and nematodes also play important roles in transforming soil nutrients.

**The chemistry of organic materials and environmental conditions** determines how rapidly organic matter is broken down, which soil organisms are involved in the decomposition process, and whether organic matter decomposition will cause an initial decrease or increase in available nutrients. The soil environment determines which soil organisms are dominant and which soil organisms are less active. Some bacterial species thrive under flooded, anaerobic conditions but most soil organisms require access to oxygen. Earthworms and some soil insects require soil that is aggregated and relatively uncompacted so they can burrow through it. Environments with limited nitrogen availability are dominated by organisms that are able to fix nitrogen from the atmosphere, such as algae, lichens, and rhizobia associated with legumes. Many soil organisms are killed by non-specific insecticides as well as by highly concentrated fertilizers such as anhydrous ammonia.

As discussed previously, organic materials that are old or woody, such as tree branches, old roots, or dried grass, contain a large amount of carbon compared to nitrogen. To decompose these materials, soil organisms may need to extract nitrogen from the soil solution in order to balance their carbon-rich diet, thus temporarily reducing the amount of nitrogen available for plant use. Young, succulent, “first-growth” plant materials, fresh manure, and materials that have gone through primary decomposition processes by larger soil organisms contain a higher concentration of nitrogen in relation to carbon. Soil organisms more readily decompose these materials and make the nutrients in them available for plant uptake.

The type of organic matter will influence the type of soil organisms involved in the decomposition process. As each decomposer feeds, it uses some nutrients for its own growth and reproduction and releases other nutrients into the soil solution where they are available for plant growth and production. Decomposer organisms may also excrete organic materials that can either be further broken down by other soil organisms or become part of the soil humus.

In general, bacteria require more nitrogen in order to break down organic matter than do most fungi. Fungi are the dominant decomposer in forest environments since they require less nitrogen in their diet and are able to feed on woody, older, or more

fibrous materials. They are also able to survive and replicate in environments that are less moist than those required by bacteria. Bacteria are more prevalent in garden and pasture environments because they require higher amounts of nitrogen and moisture, and because they feed readily on fresh manure, young grasses, legumes, and other easy-to-decompose materials (10).

#### **The chemistry of organic materials and environmental conditions determines:**

- **how rapidly organic matter is broken down**
- **which soil organisms are involved in the decomposition process**
- **whether nutrient availability will increase or decrease in the short term**

---

## **PRIMARY DECOMPOSERS**

---

Earthworms are primary decomposers of leaf litter and manure piles. Research conducted in Denmark showed that earthworms were responsible for 50% of the breakdown and disappearance of cow manure, while dung beetle larvae accounted for between 14 and 20% (76). These organisms also consume fresh organic materials, then deposit their feces in the soil. When they burrow, they move manure and other organic

**Earthworms and dung beetles are visible indicators of soil health: their presence shows that nutrient decomposition processes are occurring and the soil food web is effectively operating.**

materials into the soil, where it is more accessible to other organisms involved in decomposition. Burrowing organisms also aerate the soil. Good aeration promotes the growth of the majority of organisms involved in organic matter decomposition. For this reason, earthworms and dung beetles are visible indicators of soil health: their presence shows that nutrient decomposition processes are occurring and the soil food web is effectively operating.

### EARTHWORMS

According to research studies, the weight of earthworms in the soil is directly related to pasture productivity (77). In healthy soils with abundant earthworms, these organisms consume between 65 and 80 tons of manure per acre per year (39). Earthworms also break down pasture thatch and incorporate organic matter from the thatch into the soil. Where few or no earthworms are present, pastures develop a thick thatch layer, slow rates of organic matter decomposition, and a poor crumb structure (39).



Decomposition of organic matter by earthworms speeds up the breakdown and release of plant nutrients, particularly nitrogen and phosphorus. Earthworms consume low-nitrogen plant materials as well as high-nitrogen manure (39). Under pasture conditions, earthworms have been shown to mineralize 10 pounds per acre per year of phosphorus in their casts (5). Earthworms also facilitate the transformation of straw and leaf litter into soil humus (78). The earthworm gut combines decomposed organic matter with particles of mineral soil and microorganisms, forming soil aggregates and humus-coated soil minerals.

Through their feeding and burrowing activities, earthworms move organic matter through the soil enhancing soil aeration, water infiltration, and soil structure. They also improve root growth by creating channels lined with nutrients (79) and help till the soil. They can completely

#### Through their feeding and burrowing activities, earthworms

- break down large residues
- produce nutrient-rich casts
- move organic matter through the soil
- enhance soil aeration, water infiltration, and soil structure
- improve root growth

mix the top six inches of a humid grassland soil in 10 to 20 years (80).

Factors that contribute to an abundant population of earthworms include inputs of fresh organic matter, a medium-textured soil, thick topsoil, a near-neutral pH, moist but well-aerated soil, and moderate temperatures. Tillage, acid-producing fertilizers, insecticides, and poorly-drained soils inhibit earthworm survival (79).

### DUNG BEETLES

Dung beetles improve nutrient cycling, enhance soil aeration, and improve forage growth while feeding on manure and using it to provide housing and food for their young. Adult dung beetles

An adequate population and mix of dung beetle species can remove a complete dung pile from the soil surface within 24 hours.

are drawn to manure by odor. They use the liquid contents for nourishment and the roughage to form a brood ball in which the female lays a single egg. This brood ball is buried in the soil where the larva grows, eating about 40 to 50% of

the interior contents of the ball while depositing its own excrement. After the larva emerges, secondary decomposers readily break down the remaining dung ball (81).

An adequate population and mix of dung beetle species can remove a complete dung pile from the soil surface within 24 hours (82).

This process decreases the potential for ammonia volatilization and nutrient runoff while making manure nutrients available to secondary decomposers within the soil profile. While moving dung into the soil, dung beetles create tunnels that enhance soil aeration and water infiltration. Dung removal also increases forage availability, since it minimizes the areas that animals are avoiding because of the presence of manure.



Environmental conditions that enhance activities of dung beetles include adequate soil moisture levels and warm temperatures. Dung beetle larvae are susceptible to some insecticides used for fly and internal-parasite control for cattle. Both injectable and pour-on formulations of Ivermectin (Ivomec and Doramectin), applied to cattle at the recommended dosages, reduce survival of the larvae for one to three weeks. However, when administered as a bolus, effects on dung beetle populations last up to 20 weeks (83).

---

## SECONDARY DECOMPOSERS

---

Soil organisms are not only responsible for the mineralization and release of nutrients from organic material; they are also important for retaining nutrients in the soil, improving soil structure through the formation of aggregates and humus, degrading toxic substances, and suppressing diseases. Nutrients held in the bodies of soil organisms gradually become available for plant uptake and meanwhile they are protected against being lost through leaching, runoff, or other processes. Soil organisms involved in nutrient cycling release nutrients as they defecate and die. While they are still alive, these organisms conserve nutrients within their bodies.

### Soil microorganisms are responsible for

- mineralizing nutrients
- retaining nutrients in the soil
- forming aggregates
- degrading toxic substances
- suppressing diseases

## BACTERIA AND FUNGI

Bacteria and fungi are the most prevalent soil organisms. Bacterial decomposers feed on root exudates as well as on plant litter and manure. Maintaining actively growing soil roots provides a nutrient-rich habitat for the growth of many bacterial species. Some species of bacteria are able to detoxify pollutants while other species, particularly rhizobia and cyanobacteria (“bluegreen algae”), are able to fix nitrogen. Bacterial gels are an important component of soil aggregates. Fungi decompose complex or more

carbon-rich forms of organic matter. They also form soil aggregates by binding them with fungal threads or *hyphae*.

Mycorrhizal fungi enhance the nutrient and water uptake of plants by extending the length and surface-area of root uptake.

In dry rangelands, crusts composed of green algae, bacteria, cyanobacteria, lichens, and fungi form over

the soil surface. These crusts provide surface cover, erosion control, and soil aggregation. They are also involved in nitrogen fixation and nutrient decomposition. Crust organisms are most active during the cooler, moister part of the year when plant cover is minimal (2).

## AMOEBAS, NEMATODES, AND PROTOZOA

Amoebas, nematodes, and protozoa feed on bacteria and fungi. Nematodes may consume up to 25% of the bacteria in the soil (84). According to one study, nematodes feeding on bacteria accelerated litter decomposition by 23% (85). Both protozoa and nematodes release nutrients to the soil system, making them available to plants and other soil organisms.

## MUTUALISTIC RELATIONSHIPS

In undisturbed ecosystems, plants and soil organisms have coevolved to form mutualistic relationships. Plants provide carbohydrates and other nutrient-rich substances through their root system, providing an excellent source of food for soil organisms. As a result, populations of soil organisms involved in nutrient decomposition are greatest next to plant roots (85). These organisms provide plants with nutrients necessary for their growth, produce hormones and other chemicals that improve plant vigor, and protect the plant against diseases. When the plant’s need for nutrients is low, soil organisms will hold nutrients in their bodies rather than release them into the soil solution (10). This mutualistic relationship is disturbed by cultivation and harvesting. When plant roots are removed, populations of soil organisms decrease since they no longer have a source of nourishment and habitat.



## SOIL ORGANISMS AND SOIL HEALTH

*Soil health* refers to the ability of soils to function as a productive environment for plant growth, an effective filter, and an efficient regulator of water flow. Soil mineralogy and chemistry form the basis for soil composition and soil health. However, much of soil health and function depends on an active community of diverse soil organisms. Nutrient cycling, aggregate for-

mation, degradation of toxins, creation of soil pores, and absorption of water and nutrients are all functions of soil organisms.

The activities of soil organisms serve as effective indicators of current land productivity and its ability to withstand degradation. By monitoring these indicators, farmers, soil conservationists, and other land managers can implement appropriate practices to minimize soil or nutrient losses, enhance nutrient cycling, and increase plant productivity. The Soil Quality Institute has taken the lead in developing and promoting the use of soil health indicators (86).

**Table 15. Pasture Soil Health Card.**

Indicator	Good	Medium	Poor
Pasture cover	Complete cover of forages and litter over entire pasture.	Limited bare patches. No extensive bare areas near drainage areas.	Extensive bare patches especially near watering or other congregation areas.
Plant diversity	Diversity of plant species, including forbs, legumes, and grasses, and differences in leaf and root growth habits.	Limited number of species and limited diversity of growth habit. Some invasive plants present.	Less than three different species, or invasive species are a major component of the plant mix.
Plant roots	Abundant vertical and horizontal roots.	More horizontal roots than vertical.	Few roots; most are horizontal.
Soil life – macroorganisms	Many dung beetles and earthworms present.	Few dung beetles and earthworms present.	No dung beetles or earthworms present.
Soil compaction	Wire flag enters soil easily, and does not encounter hardened area at depth.	Wire flag pushed into soil with difficulty, or encounters hardened area at depth.	Wire flag cannot be pushed into soil.
Erosion	No gullies present; water running off pasture is clear.	Small rivulets present; water running off pasture is somewhat muddy.	Gullies present; water running off pasture is very muddy.
Soil aggregation	Soil in clumps; holds together when swirled in water.	Soil breaks apart after gentle swirling in water.	Soil breaks apart within one minute in water.
Water infiltration	Water soaks in during moderate rain; little runoff or water ponding on soil surface.	Some runoff during moderate rainfall, some ponding on soil surface.	Significant runoff during moderate rainfall; much water ponding on soil surface.

Adapted from the Georgia, Mon-Dak, and Pennsylvania Soil Health Cards (86) Sullivan (88) and USDA (89).

Qualitative “farm-based” and “farmer friendly” indicators are incorporated into soil health cards specific to location and farming practice (87). These cards can be used to monitor the relative health and productivity of soils, identify areas

of concern, and enhance awareness of the relationships between soil health and crop production. Below is a soil health card for pastures based on a compilation of indicators from soil health cards developed in various locations.

## Table 16. Soil Organisms.

**Bacteria** – the most numerous microorganism in the soil. Every gram of soil contains at least a million of these tiny one-celled organisms. Decompose simple or nitrogen-rich organic matter. Require moist environments. Also responsible for nitrogen fixation, soil aggregate formation, and detoxification of pollutants.

**Actinomycetes** – thread-like bacteria, which look like fungi. They are decomposers and are responsible for the sweet, earthy smell of biologically active soil.

**Fungi** – multicellular microorganisms that usually have a thread-like structure. Mycorrhizae form extensions on roots, increasing their ability to take up nutrients and water. They also transport nitrogen from legumes to grasses. Yeasts, slime molds, and mushrooms are other species of fungi.

**Algae** – microorganisms that are able to make their own food through photosynthesis. They often appear as a greenish film on the soil surface following a rainfall.

**Protozoa** – free-living animals that crawl or swim in the water between soil particles. Many soil protozoan species are predatory and eat other microorganisms. By feeding on bacteria they stimulate growth and multiplication of bacteria and the formation of gels that produce soil aggregates.

**Nematodes** – small wormlike organisms that are abundant in most soils. Most nematodes help decompose organic matter. Some nematodes are predators on plant-disease-causing fungi. A few species of nematodes form parasitic galls on plant roots or stems, causing plant diseases.

**Earthworms** – multicellular organisms that decompose and move organic matter through the soil. Earthworms thrive where there is little or no tillage, especially in the spring and fall, which are their most active periods. They prefer a near neutral pH, moist soil conditions, an abundance of plant residues, and low light conditions.

**Other species of soil organisms** – Many other organisms, including dung beetles, sowbugs, millipedes, centipedes, mites, slugs, snails, springtails, ants, and birds facilitate nutrient cycling. They make residues more available to smaller organisms by breaking them down physically and chemically and by burying them in the soil.

## Table 17. Pasture Management Practices to Maintain a Healthy Soil Food Web.

### Provide soil organisms with a balanced diet

- Manure and perennial pastures provide food for soil organisms
- Succulent materials that are more nitrogen-rich are more rapidly decomposed than materials that are older and woodier and contain less nitrogen

### Provide soil organisms with a favorable environment

- Most beneficial soil organisms prefer a well-aerated environment
- Decomposer bacteria generally prefer an environment that is moist, has a near neutral pH, and has easy-to-decompose materials
- Decomposer fungi generally prefer an environment that is acid, moderately dry, and has more carbon-rich, complex organic materials
- Continuous plant growth maintains environment of actively growing roots in the soil. The root or rhizosphere environment is a very nutrient-rich habitat for the growth of many soil organisms

### Use practices that favor the growth of soil organisms

- Maintain a balance between intense grazing and adequate rest or fallow time
- Encourage movement of grazing animals across pastures to feed and distribute manure evenly as well as to kick and trample manure piles
- Maintain a diversity of forage species to provide a variety of food sources and habitats for a diversity of soil organisms

### Avoid practices that kill or destroy the habitat of soil organisms

- Avoid the use of Ivomectin deworming medications, soil-applied insecticides, and concentrated fertilizers such as anhydrous ammonia and superphosphate
- Minimize tillage and other cultivation practices
- Minimize practices that compact the soil, such as extended grazing practices or grazing wet soils





## Chapter 5: Pasture Management and Water Quality

---

Judicious applications of fertilizers and manure enhance plant growth. However, if nutrients are applied at the wrong time or in excess of what plants can use, they increase the potential contamination of nearby rivers and lakes. Similarly, grazing practices can degrade water quality if grazing intensity is too great, if paddocks are used when the soil is too wet, or if the duration of rest periods is too short. Long-term intensive grazing practices can negatively affect water quality, especially when combined with heavy fertilization with either mineral or manure nutrients. Likely impacts include contamination of groundwater with nitrates and contamination of surface water with phosphate, sediments, and pathogens (90, 91).

---

### RISK FACTORS FOR NUTRIENT LOSSES

---

#### NUTRIENT LOSS PATHWAYS

If more manure or fertilizer nutrients are applied to pastures than are used in the growth of forage crops, excess nutrients will either accumulate in the soil or be lost through leaching, runoff, or erosion. Nutrient accumulation occurs when minerals in the soil have the ability to bind or hold particular nutrients. Sandy or silty soils or soils with a near-neutral pH do not bind phosphorus well. When more phosphorus is applied to these soils than is used for plant growth, the excess phosphorus can easily be dissolved and carried away by runoff water to lakes and streams. Both acid clay soils and soils with a high calcium carbonate content have a strong ability to bind large amounts of phosphorus. If only moderate excesses of phosphorus are applied to these soils or if excess phosphorus is applied to the soil only occasionally, these soils will be able to bind the excess phosphorus and hold it against leaching. However, if phosphorus fertilizers or manure are continually applied at high rates, phosphorus levels will eventually build up in the soil to the extent that soils will no longer be able to hold onto the additional phosphorus and these excesses will be susceptible to loss through run-

off. High levels of phosphorus in surface water cause eutrophication and algal blooms. When sources of drinking water have significant algal growth, chlorine in the water-treatment process reacts with compounds in the algae to produce substances that can increase cancer risks.

Unlike phosphorus, nitrogen does not readily bind to soil minerals or organic matter. As a result, it easily leaches through the soil, especially if high rainfall follows manure or nitrogen fertilizer applications and the soil is sandy or gravelly. High levels of nitrate in ground water used for drinking can cause health problems for human babies and immature animals. Management practices that minimize the potential for nitrogen leaching include not applying excessive nitrogen and avoiding manure or nitrogen fertilizer applications during times when plants are not actively growing.

Erosion occurs when water or wind moves soil particles, resulting in the loss of topsoil and of the nutrients, toxins, and pathogens attached to these particles. Erosion by water can also transport surface-applied manure into lakes, rivers, and streams. Water quality concerns associated with erosion include siltation, fish kills, eutrophication, and degraded quality for recreational and drinking-water uses.

#### NUTRIENT BALANCES

Water contamination problems associated with farming are becoming an increasing societal and political concern. The Federal Clean Water Act mandates states to minimize non-point-source pollution or pollution associated with runoff and erosion, much of this originating from agricultural lands (92). Currently, water quality regulations are primarily focused on larger farms that have a high concentration of animals and use high inputs of purchased feeds. Societal concerns about farming operations are increasing as more non-farm families move into rural areas and urban growth decreases the distance between farm and non-farm community members.

On farms that have high numbers of animals, a limited land area, and high use of feeds that are not grown on the farm, nutrient imbalances exist. This is because the amount of nutrients

that accumulate in the animal manure is greater than the needs of all crops being grown on the farm. Maintaining a balance between the amount of nutrients added to the soil as manure and fertilizer and the amount of nutrients removed as forages, hay, crops, or livestock is critical for productive crop growth and water quality protection. If more nutrients are removed than are returned to the system, crop production will decline. If more nutrients are added than can be used for productive crop growth, nutrients will build up in the soil, creating a high risk for leaching, runoff, and water contamination.

While environmental regulations primarily target large farms, these are not the only livestock operations at risk for contaminating water quality. Often, smaller livestock farms pose more risk than larger operations. For instance, on smaller dairy farms the barn is commonly located near a stream because it was built prior to rural electrification and the ability to pump water from wells or streams to watering troughs. On many small livestock operations, animals have access to paddocks located near a well head or over highly permeable soils because land area is limited. Riparian areas are less likely to be protected by fencing or buffer areas. On farms without adequate manure storage facilities, manure is often applied to poorly drained or frozen fields during the winter, resulting in a high potential for surface water contamination. In addition, on smaller farms, necessary equipment or labor is often not available to properly apply manure according to a nutrient management plan. Careful management of grazing and manure-handling practices is critical on all farms in order to protect water resources.

**Manure or fertilizers should be applied when the nutrients in these materials can be most effectively used for plant growth and production, and never to ground that is snow-covered, frozen, or saturated.**

---

## PATHOGENS

---

### PATHOGENS IN MANURE

Although not directly related to nutrient cycling, pathogens are a critical water quality con-

cern associated with manure management. Animal grazing and manure applications can contaminate water bodies not only with excess nutrients but also with parasites in feces. Parasites of greatest concern are *E. coli*, *Giardia*, and *Cryptosporidium*. *E. coli* is of most concern to rural residents dependent on well water and of limited concern to public water users since this parasite is killed by municipal water purification and treatment processes. Typically, this parasite causes mild to moderate gastrointestinal problems. However, new strains of *E. coli* have killed people who are very young, very old, or have weakened immune systems. *Giardia* and *Cryptosporidium* are pathogens with a dormant stage that is very resistant to purification treatment. Almost all municipal water treatment facilities are required to use secondary filtration processes that remove these resistant forms from the water supply. Most private wells, however, do not have the capability of filtering out these pathogens. Like the virulent strain of *E. coli*, *Giardia* and *Cryptosporidium* cause gastrointestinal problems that can be fatal for people with weak or undeveloped immune systems.

Minimizing the risk of pathogen movement into water bodies involves ensuring that animals, especially young calves, are not exposed to, or kept in conditions that make them susceptible to, these diseases. Any manure that potentially contains pathogens should either be completely composted before application, or applied to land far from streams and at low risk of erosion or runoff (93).

### PASTURE MANAGEMENT PRACTICES TO REDUCE RISKS OF PATHOGEN CONTAMINATION

Manure or fertilizers should be applied when the nutrients in these materials can be most effectively used for plant growth and production, and never to ground that is snow-covered, frozen, or saturated. Under such wet or frozen conditions, manure or fertilizer nutrients are not bound by soil particles. Instead, these nutrients are lying unbound on the soil surface where they have a high potential to be carried away by runoff into lakes or streams. Pathogens in manure applied to frozen or snow-covered soil will not be in contact with other soil organisms. In addition, most predatory soil organisms will be in a

dormant state and unable to decrease pathogen numbers before snowmelts or heavy rainfalls cause runoff.

Areas that need to be protected from contamination by nutrients and parasites in animal feces include well heads, depressions at the base of hills, drainage ways, rivers, streams, and lakes. Well heads and water bodies need protection because they serve as drinking and recreational water sources, while foot slopes and drainage ways have a high potential for nutrient runoff and transport of contaminants to water bodies.

---

## NITRATE CONTAMINATION

---

Nitrate is not held by soil particles and is easily leached, especially through porous soils, such as sandy soils or soils with cracks or fissures that allow for rapid movement of excess nitrogen through the soil profile. Where excess nitrogen is not applied, nitrate leaching in pastures is minimal. High nitrate leaching losses were observed, however, when orchard-grass pastures in Pennsylvania were fertilized with 200 pounds per acre of nitrogen as ammonium nitrate (45). These researchers also calculated that a stocking rate for Holstein dairy cows of 200 animal days would result in nitrate leaching from urine in excess of drinking-water standards (10 mg/liter) (45). In pastures where nitrogen was provided by nitrogen-fixing legumes, nitrate leaching was minimal when environmental conditions were normal. But high nitrate leaching was observed when a severe drought followed good growing conditions, causing legume nodules to die and release nitrogen into the soil (20).

Nitrate concentrations greater than 10 ppm in well water may cause nitrate toxicity or methemoglobinemia. This ailment, which affects infant children as well as young chickens and pigs, and both infant and adult sheep, cattle, and horses, increases nitrate concentration in the bloodstream and prevents the uptake and use of oxygen, thus causing suffocation. Pregnant animals that are affected may recover, then abort within a few days (21). Personnel associated with

local health departments can test wells to determine nitrate concentrations.

---

## PHOSPHORUS CONTAMINATION

---

Phosphorus can be transported from fields or pastures into lakes or streams either as a component of erosion or within runoff water. Phosphorus that is dissolved in runoff water has a greater effect on water quality than phosphorus that is attached to soil particles transported to water bodies by erosion (94). This is because the dissolved phosphorus is more available for use by algae and other aquatic organisms that cause eutrophication, noxious greening of water bodies, and fish kills. Phosphorus associated with soil particles tends to settle to the lake or river bottom where it remains biologically stable or only slowly available for use by aquatic organisms.

### DISSOLVED PHOSPHORUS

In pastures, sources of dissolved phosphorus include manure or phosphorus fertilizers lying on the soil surface, and wet soils that have a high phosphorus concentration. Runoff water can readily dissolve soluble phosphorus in manure or phosphorus fertilizers. When the amount of phosphorus in soil exceeds the ability of soil particles to bind onto it, the excess phosphorus can readily be dissolved and transported by runoff water, especially when soils are saturated. Dissolved phosphorus has the greatest potential for being transported from pastures into water bodies when rainfall is heavy, when high levels of phosphorus are present either on the surface of the soil or within the soil, and when pastures are located within 350 feet of water bodies (95).

Increasing forage diversity generally decreases runoff potential. Care should be taken to combine species, such as bunch-grasses, that enhance water infiltration but expose the soil surface between clumps (96), with closer-growing species such as tall fescue or prostrate species such as white clover. A combination of native

**High nitrate leaching occurs when a severe drought follows good growing conditions, causing legume nodules to die and release nitrogen into the soil.**

**When the amount of phosphorus in soil exceeds the ability of soil particles to bind onto it, the excess phosphorus can readily be dissolved and transported by runoff water, especially when soils are saturated.**

forages and low-growing, shade-tolerant plants could enhance both water infiltration and cattle production (D. Brauer, personal communication). Setting up paddocks on the contour can also allow downslope paddocks that are regenerating after grazing to serve as buffer strips for upslope paddocks that are currently being grazed. Potential runoff from manure can also be reduced by applying it to alternate paddocks set up as contour strips (D.E. Carman, personal communication).

### **PHOSPHORUS ASSOCIATED WITH EROSION**

Soil-attached phosphorus can be transported to water bodies by erosion. Low-level sheet erosion contributes more phosphorus than higher-impact rill or gully erosion. This is because sheet erosion primarily transports nutrient-enriched topsoil, manure, and plant residues while gully erosion transports more nutrient-poor subsoil (27). As with runoff, the amount of phosphorus transported by erosion is greatest during intense rainfalls or snowmelts. Pasture soils that are completely covered by vegetation are protected against the forces of erosion. Erosion occurs primarily when soils are bare and land is sloping.

### **IMPACT OF PHOSPHORUS**

#### **CONTAMINATION ON WATER QUALITY**

The impact of phosphorus runoff on stream or lake water quality is greatest during summer and fall. While spring rains or snowmelts may transport a greater total amount of phosphorus, the large amount of water in the runoff dilutes the phosphorus so that it is in a relatively low concentration when it reaches water bodies. In contrast, intense rains falling on soils and pastures during the summer are likely to run off rather than soaking into dry, hard soils. When intense rains fall on pastures with surface-applied manure or phosphorus fertilizers, runoff water will carry a high concentration of dissolved phosphorus into streams. If these streams have relatively low water flows, the runoff water will create a high concentration of phosphorus in

streams, which then causes algae and other nuisance plants to grow (27).

### **Table 18. Impacts of excess phosphorus on water quality.**

- **Excessive phosphorus stimulates growth of algae and aquatic weeds in lakes and streams**
- **Rapid algal and aquatic-weed growth depletes oxygen from water, leading to death of fish**
- **Outbreaks of certain aquatic organisms dependent on high phosphorus levels can cause health problems in humans, livestock, and other animals**
- **When water that has high algal growth is chlorinated for use as drinking water, carcinogenic substances are formed**

The type of phosphorus fertilizer used influences the potential risk of water contamination. Highly soluble fertilizers such as superphosphate present a greater short-term potential for phosphorus loss since they are easily dissolved and transported. In the long term, however, less-soluble fertilizers, such as dicalcium phosphate, may pose a greater risk. This is because less-soluble fertilizer remains on the soil surface and available for dissolution and runoff for a longer time (27). Impacts on water quality from sediment-attached phosphorus fertilizer have been observed to persist for up to six months (97). Runoff risks can be substantially decreased if fertilizers are incorporated into soil and applied according to a nutrient management plan.

### **PHOSPHORUS INDEX**

The phosphorus index was developed to address federal and state water quality guidelines while recognizing that phosphorus movement is influenced by local environmental conditions and land management practices. Each state is developing their own phosphorus index to ensure that it is appropriate to local conditions. Each phosphorus index contains a component related to phosphorus sources, soil-test phosphorus, manure phosphorus, and fertilizer phosphorus. (Soil-test phosphorus accounts for the plant-

available or soluble phosphorus in the soil, derived either from the mineral base of the soil or from decomposing organic matter.) The potential for manure or fertilizer phosphorus to be lost through runoff depends on the amount applied, how it was applied, and when it was applied. Manure and fertilizer incorporated into the soil at rates required for crop growth, and at or just prior to the time of crop production, pose minimal risk to water quality. Conversely, surface-applying excessive amounts of manure or fertilizer when crops are not actively growing or when the soil is saturated, frozen, or snow-covered will pose high risks for phosphorus runoff. However, a high concentration of phosphorus in the soil or applied to the soil will not pose a risk to water quality unless there is a means of transporting this phosphorus to water bodies. Methods for transporting phosphorus from farm fields to water bodies include erosion, runoff, and flooding. Locations that have a high source of phosphorus and a high risk of transport are *critical source areas* or locations where land managers need to carefully consider risks of phosphorus losses.

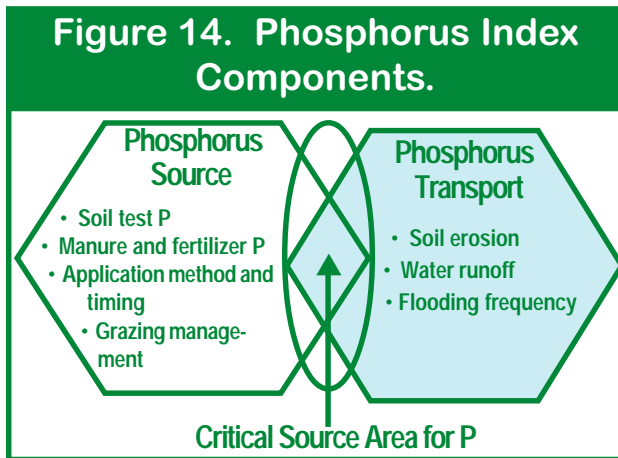

## SUBSURFACE DRAINAGE

Artificial subsurface drainage makes normally wet soils drier, and decreases the wet period for seasonally wet soils, by allowing more water to seep into the soil profile. Subsurface drainage has been shown to decrease water runoff by 72% and total phosphorus losses due to runoff by 50% (5).

## CONTAMINANT TRANSPORT THROUGH DRAINS

Unfortunately, the advantage that subsurface drainage provides in decreasing runoff potential may be overshadowed by the ability of drainage systems to directly transport nutrients from fields to waterways. Most subsurface drainage systems were installed primarily for production reasons: to allow farmers to work their fields earlier in the year and to minimize plant stunting and disease problems associated with saturated soils. Since many of these systems were installed before agricultural impacts on water quality became a societal concern, agricultural drains often empty directly into streams and rivers.

During wet periods of the year, artificially drained fields should be managed as though they were not drained. Grazing, manure spreading, and fertilizer applications should be avoided while drains are flowing.

Because artificial drainage makes fields drier, farmers can drive tractors or other equipment onto these fields earlier in the year. Farmers who have a full manure-storage system to empty, or who have time constraints for spreading manure in advance of planting, may be tempted to apply manure and fertilizers to these fields during times when the soil would be wet if it were not drained. Farmers with a limited land base may want to graze these fields when the weather is wet. However, to protect water quality, these fields should be managed as though artificial drainage had not been installed. Nutrients in fertilizers or manure can leach through the soil to drainage pipes. If artificially drained fields are used for nutrient applications or grazing while water is flowing out of drainage outlets, drainage water can carry these leached nutrients directly to streams or rivers.

In soils with subsurface drainage, cracks and channels provide a direct pathway for nitrate, phosphorus, or soluble manure to move from the soil surface to subsurface drains (6, 78). Because these channels are relatively large, contaminants are not absorbed by soil particles or biologically treated by soil organisms (27). Soil cracks or

**Tile drainage water should be directed to a grassed filter or buffer area, or treated in a wetlands area where biological and chemical processes lower contaminant levels.**

channels develop through earthworm burrowing, death and decomposition of taproots, and soil drying. The direct connection of cracks or channels in soils to artificial drainage pipes can transport phosphorus and pathogens from manure applications directly to drainage outlets within an hour after the onset of a heavy rain (6). One research study showed that a single rotational grazing event doubled the amount of sediment and increased the amount of dissolved phosphorus in tile drainage water 15-fold compared to an ungrazed site (5).

### MANAGEMENT PRACTICES

To minimize the potential for water contamination, land that is artificially drained should not be grazed or have fertilizer or manure applied during times when drainage water is flowing from the field or just prior to a rainstorm. Alternatively, contaminated water flowing out of tile drains should not be allowed to empty directly into rivers or streams. Instead, it should be directed to a grassed filter or buffer area, or treated in a wetlands area where biological and chemical processes lower contaminant levels through sedimentation and absorption (27).

---

## RIPARIAN BUFFERS

---

A well-designed buffer with a combination of trees, shrubs, and herbaceous plants has the ability to trap sediments and nutrients associated with the sediments. Buffers also provide habitat for river-bank and aquatic animals. An effective buffer for trapping sediments contains a combination of grasses and herbaceous plants that are able to catch sediments in their foliage or residues. The root channels around actively growing plants will also absorb slow-moving runoff water and plants in the buffer area will use transported nutrients for their growth. Regular harvest and removal of buffer vegetation can delay or prevent the buildup of nutrients in the buffer area. However, harvests must be conducted in a manner that does not decrease the ability of buff-

ers to capture sediments and absorb runoff water.

Riparian buffers are limited in their ability to remove soluble phosphorus and nitrate from runoff water, especially if flows are intense (98). During heavy rainstorms or rapid snowmelts, buffers generally have limited effectiveness for controlling the movement of runoff-borne nutrients into water bodies. This is because water from these heavy flows concentrates into rapidly moving channels that can flow over or through buffer areas.

**As phosphorus is continually transported into buffers, soils in the buffer area will eventually lose their ability to hold additional phosphorus, thus limiting their effectiveness to control phosphorus movement into streams.**

The continual transport of phosphorus-rich sediments into buffers will cause a buildup of high concentrations of phosphorus in buffer areas. Eventually, these areas will lose their ability to hold additional phosphorus. Buffer areas can actually become a *source* of phosphorus entering water bodies, rather than an area that captures phosphorus before it enters water bodies (99).

---

## RIPARIAN GRAZING

---

When grazing animals have continuous, unlimited access to riparian areas, their activities break down stream banks, alter stream flow, cause decreased vigor of stream-bank vegetation, and diminish the species diversity and populations of fish and aquatic wildlife (100, 101). Cattle



grazing in riparian areas trample on streamside and aquatic organisms, disturb the habitat of these organisms, decrease oxygen availability by suspending bottom sediments, and contaminate streams by directly depositing manure and urine (102). Animal movement along streambanks or within streams also contributes to bank erosion. In addition, grazing activities alter the amount and type of plant residues available for the growth and reproduction of riparian organisms (90).

**Limiting animal access to riparian areas allows a thick vegetative turf to develop throughout the paddock, which stabilizes stream banks and reduces stream-bank erosion.**

Managed grazing of riparian areas can protect water quality and improve riparian habitat. In Wisconsin, researchers studying intensive rotational grazing practices restricted livestock access to riparian areas to 5 to 20 days per season. Limiting animal access to riparian areas allowed a thick vegetative turf to develop throughout the paddock, which stabilized stream banks and reduced streambank erosion (102). For dairy cattle, each grazing period should last only 12 to 24 hours, while beef cattle and sheep can be grazed for 3 to 4 days each time (103). Grazing should not be allowed to reduce herbage stubble to less than 4 to 6 inches in height. This will protect water quality by providing adequate plant

growth, bank protection, and sediment entrapment (104).

Pasture management practices should discourage animals from congregating in the stream or on the stream bank, where their manure can pollute water. Shade, salt licks, and other sources of supplemental nutrients should be located at least 15 feet from the stream bank to provide a buffer between areas of manure deposition and the stream (100).

The season in which riparian areas are grazed is also an important consideration if water quality is to be protected. Grazing in the spring or early summer followed by complete livestock removal in the summer allows riparian plant regrowth to occur before the dormant period in the fall. Animals will damage stream banks if they are allowed to graze riparian areas in the winter when soils are freezing and thawing or in the spring when soils are wet. During drought conditions, streambanks should not be grazed since vegetation will be slow to recover. Animals should not be allowed to graze riparian areas in the summer, when hot dry conditions would encourage cattle to congregate in the water (103). Stream banks that have a high soil moisture content or a fine soil texture, or that are prone to erosion, are subject to early-season grazing damage and should not be grazed in the spring or not until they have dried (104). Use of floating fences and graveled access areas can control animal access to water, minimizing the impacts on stream-bank stability and ecology.

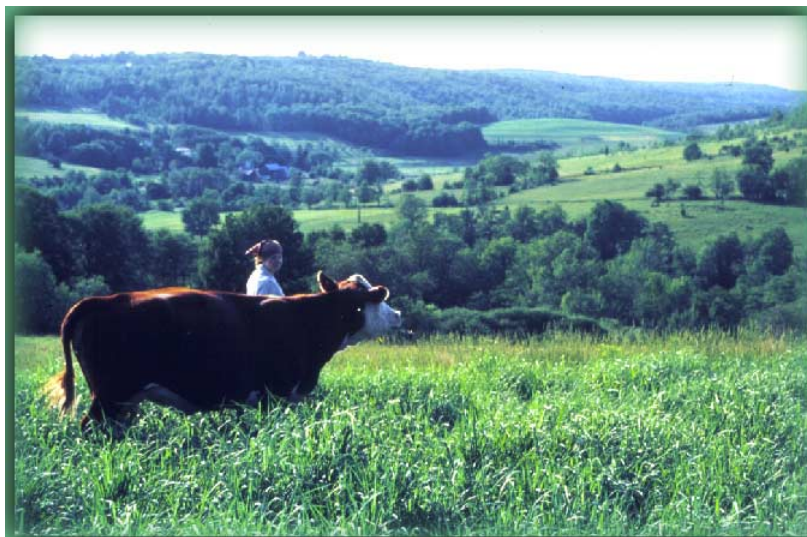

**Table 19.**  
**Pasture Management Practices to Protect Water Quality.**

**Minimize congregation of animals in pastures**

- Use practices that encourage the movement of animals across paddocks
- Avoid overgrazing of pastures

**Minimize the potential for nitrate leaching**

- Encourage animal movement across paddocks
- Maintain a healthy cover of actively growing forages across paddocks
- Rotate pastures to maximize nutrient uptake by plants

**Minimize the potential for nutrient runoff**

- Do not apply fertilizers or manure to saturated, snow-covered, or frozen ground
- If possible, compost manure before applying it to soil. This will minimize pathogen populations while transforming nutrients into more stable compounds
- Do not use pastures that are wet, flooded, or saturated
- Use practices that favor populations of soil organisms that rapidly incorporate manure into the soil
- During cold or wet weather, do not use pastures that are located next to a river, stream, or waterway
- Recognize that buffers are not effective in controlling the movement of nutrients carried by runoff water, especially when flows are intense

**Minimize the potential for erosion**

- Maintain a complete cover of forages and residues across the surface of all paddocks
- Use practices that minimize the congregation of animals or the repeated trampling of animals on the same lounging area or pathway
- Riparian areas should only be grazed using short-term intensive grazing practices, and then only during spring and early summer
- Maintain riparian buffers (including a combination of herbaceous plants, trees, and shrubs) adjacent to rivers, streams, and lakes to act as a filter for eroded soil and other contaminants

**Minimize water contamination from artificial drainage systems**

- During wet weather, do not use pastures that are on artificially-drained land
- Modify outlets from drainage ways to treat drainage water in wetlands or on filter areas before it flows into streams or other water bodies



## References

1. Magdoff, F. and H. van Es. 2000. Building Soils for Better Crops, Second Edition. Sustainable Agriculture Network. Handbook Series Book 4. Beltsville, MD.
2. Belnap, J., H.H. Kaltenecker, R. Rosentreter, J. Williams, S. Leonard, and D. Eldridge. 2001. Biological Soil Crusts: Ecology and Management. Technical Reference 1730-2. United States Department of the Interior. Bureau of Land Management. Denver, CO. Accessed at < <http://www.blm.gov:80/nstc/library/techref.htm>>.
3. Welch, T.G., R.W. Knight, D. Caudle, A. Garza, and J.M. Sweeten. 1991. Impact of Grazing Management on Nonpoint Source Pollution. Texas Agricultural Extension Service. Extension Resource Center. Document L-5002. Accessed at <<http://texaserc.tamu.edu/catalog/query.cgi?id=433>>.
4. Pellant, M., P. Shaver, D.A. Pyke, and J.E. Herrick. 2000. Interpreting Indicators of Rangeland Health. Version 3. Technical Reference 1734-6. United States Department of Agriculture. Bureau of Land Management. National Science and Technology Center Information and Communications Group. Denver, CO. Accessed at <<http://www.ftw.nrcs.usda.gov/glti/pubs.html>>.
5. Sharpley, A.N. and J.K. Syers. 1979. Loss of nitrogen and phosphorus in tile drainage as influenced by urea application and grazing animals. *New Zealand Journal of Agricultural Research*. Volume 22. p. 127-131.
6. van Es, H. and L. Geohring. 1993. Rapid movement of manure to tile drainage lines: Should we be concerned? What's Cropping Up? Vol. 3, No. 4. p. 5, 7.
7. Hillel, D. 1998. *Environmental Soil Physics*. Academic Press. San Diego, CA.
8. Thurow, T.L., W.H. Blackburn, and C.A. Taylor, Jr. 1988. Infiltration and interrill erosion responses to selected livestock grazing strategies, Edwards Plateau, TX. *Journal of Range Management*. Vol. 41. p. 296-302.
9. Pearson, C.J. and R.L. Ison. 1987. *Agronomy of Grassland Systems*. Cambridge University Press, Cambridge. p. 62-78.
10. Ingham, E. 1996. The soil foodweb: Its importance in ecosystem health. Home page. Accessed at <<http://rain.org:80/~sals/ingham.html>>.
11. Whitehead, D.C. 2000. *Nutrient Elements in Grassland Soil-Plant-Animal Relationships*. CAB International Publishing. Wallingford, Oxon, UK.
12. Woodmansee, R.G., I. Vallis, and J.J. Mott. 1981. Grassland Nitrogen. In: F.E. Clark and T. Rosswall. (eds.) *Terrestrial Nitrogen Cycles: Processes, Ecosystem Strategies and Management Impacts*. *Ecological Bulletins*. Stockholm. Vol. 33. p. 443-462.
13. Joost, R. 1996. Pasture Soil Fertility Management. p. 35-46. In: J. Gerrish and C. Roberts (eds.) 1996 *Missouri Grazing Manual*. University of Missouri. Columbia, MO.
14. West, C.P. and A.P. Mallarino. 1996. Nitrogen transfer from legumes to grasses. In: R.E. Joost and C.A. Roberts (eds.) *Nutrient Cycling in Forage Systems*. Potash and Phosphate Institute and Foundation of Agronomic Research. Manhattan, KS.
15. Brophy, L.S., G.H. Hiechel, and M.P. Russelle. 1987. Nitrogen transfer from forage legumes to grasses in a systematic planting design. *Crop Science*. Vol. 27. p. 753-758.
16. Thomas, R.J. 1992. The role of the legume in the nitrogen cycle of productive and sustainable pastures. *Grass Forage Science*. Vol. 47. p. 133-142.
17. Russelle, M.P. 1992. Nitrogen cycling in pasture and range. *Journal of Production Agriculture*. Vol. 5, No. 1 p. 13-23.
18. Clough, T.J., R.R. Sherlock, K.C. Carmeron, and S.F. Ledgard. 1996. Fate of urine nitrogen on mineral and peat soils in New Zealand. *Plant and Soil*. Vol. 178. p. 141-152.
19. Williams, P.H. and R.J. Haynes. 1994. Comparison of initial wetting pattern, nutrient concentrations in soil solution and the fate of <sup>15</sup>N-labelled urine in sheep and cattle urine patch areas of pasture soil. *Plant and Soil*. Vol. 162. p. 49-59.

20. Stout, W.L., S.L. Fales, L.D. Muller, R.R. Schnabel, and S.R. Weaver. 2000. Water quality implications of nitrate leaching from intensively grazed pasture swards in the northeast US. *Agriculture, Ecosystems, and Environment*. Vol. 77. p. 203-210.
21. Eubank, W., J.D. Carpenter, B.A. Maltberger, N. Anderson, and K. Mancl. 1998. Nitrate in Drinking Water. Water quality Initiative publication WQ103. Available at <<http://muextension.missouri.edu/xplor/waterq/wq0103.htm>>.
22. Anon. 1988. Watch out for nitrate toxicity. *Wallace's Farmer*. August 9, 1988. p. 48.
23. Daniels, M., T. Daniel, D. Carman, R. Morgan, J. Langston, and K. VanDevender. 1998. Soil Phosphorus Levels: Concerns and Recommendations. University of Arkansas. Division of Agriculture. Cooperative Extension Service. Accessed at <<http://www.soil.ncsu.edu/sera17/publicat.htm>>.
24. Moore, P.A. Jr. and P.R. DeLaune. 2000. Development of a phosphorus index for pastures: I. Rainfall simulation data. Proceedings of the Southern American Society of Agronomy Meeting.
25. Lemunyon, J.L. and R. G. Gilbert. 1993. The concept and need for a phosphorus assessment tool. *Journal of Production Agriculture*. 6: 483-486.
26. Snyder, C.S., T.W. Bruulsema, A.N. Sharpley, and D.B. Beegle. 1998. Site-specific use of the environmental phosphorus index concept. Site-Specific Management Guideline-1. Potash and Phosphate Institute. Conway, AR.
27. Gillingham, A.G. and B.S. Thorrold. 2000. A review of New Zealand research measuring phosphorus in runoff from pasture. *Journal of Environmental Quality*. Vol. 29. p. 88-96.
28. Cherney, J.H. 1996. Potassium content of grasses for dairy cattle. What's Cropping Up? Vol. 6. No. 3. p. 6-7.
29. Albrecht, W.A. and C. Walters, Jr. (eds.) 1975. *The Albrecht Papers (Vols. I-IV)*. Acres U.S.A., Kansas, MO.
30. Lock, T.R., R.L. Kallenbach, D.G. Blevins, T.M. Reinbott, G.J. Bishop-Hurley, R.J. Crawford, Jr. and M.D. Massie. 2001. Fertilizing tall fescue pastures with phosphorus to prevent grass tetany in grazing beef cows. In: T. Terrill and K. Cassida (eds.) *American Forage and Grassland Council Proceedings*. American Grassland Council. Georgetown, TX.
31. Manning, E. 2000. Sulfur's big boost. *Progressive Farmer*. Vol. 15, No. 11. p. 74.
32. Kallenbach, R., R. Mammen, T. Hansen. 2000. Forage crops for pasture-based dairies. In: J. Bishop-Hurley, S.A. Hamilton, and R. Kallenbach (eds.) *Missouri Dairy Grazing Manual*. Missouri University Extension. University of Missouri, Columbia, MO.
33. Evans, R.D. and J.R. Johansen. 1999. Microbiotic crusts and ecosystem processes. *Critical Reviews in Plant Sciences*. Vol. 18, No. 2. p. 183-225.
34. United States Department of Agriculture/ Natural Resources Conservation Service. 2001. Rangeland Soil Quality-Physical and Biological Soil Crusts. Soil Quality Information Sheet. Rangeland Sheet 7. Accessed at <<http://www.statlab.iastate.edu/survey/SQI/range.html#SQIS>>.
35. Matches, A.G. 1992. Plant response to grazing: A review. *Journal of Production Agriculture*. Vol. 5. p. 1-7.
36. Gerrish, J.R. 1993. Management intensive grazing: principles and techniques. In: *Stockman Grass Farmer North American Grazing Conference*. Jackson, MS.
37. United States Department of Agriculture/ Natural Resources Conservation Service. 2001. Rangeland Soil Quality-Compaction. Soil Quality Information Sheet. Rangeland Sheet 4. Accessed at <<http://www.statlab.iastate.edu/survey/SQI/range.html#SQIS>>.
38. Zinati, G.M., Y.C. Li, and H.H. Bryan. 2001. Utilization of compost increases organic carbon and its humin, humic and fulvic acid fractions in calcareous soil. *Compost Science and Utilization*. Vol. 9. No. 2. p. 156-162.

39. Edwards, C.A. and P.J. Bohlen. 1996. *Biology and Ecology of Earthworms*. Chapman & Hall, New York.
40. United States Department of Agriculture/Natural Resources Conservation Service. 2001. Rangeland Soil Quality-Aggregate Stability. Soil Quality Information Sheet. Rangeland Sheet 3. Accessed at <<http://www.statlab.iastate.edu/survey/SQI/range.html#SQIS>>.
41. Haynes, R.J. and P.H. Williams. 1993. *Nutrient Cycling and Soil Fertility in the Grazed Pasture Ecosystem*. Academic Press Inc.
42. Lory, J. and C. Roberts. 2000. Managing nutrients in pastures to improve profitability and water quality. In: G. J. Bishop-Hurley, S.A. Hamilton, and R. Kallenbach (eds.) *Missouri Dairy Grazing Manual*. Missouri University Extension. University of Missouri. Columbia, MO.
43. Horne, J. 1992. Soil fertility affects pasture winter hardiness and moisture use efficiency. *KCSA Newsletter*. Vol. 18, No. 11. p. 1.
44. Klausner, S. 1995. *Nutrient management: Crop production and water quality*. Cornell Cooperative Extension, Ithaca, NY.
45. Stout, W.L., S.L. Fales, L.D. Muller, R.R. Schnabel, G.F. Elwinger, and S.R. Weaver. 2000. Assessing the effect of management intensive grazing on water quality in the northeast US. *Journal of Soil and Water Conservation*. Vol. 55, No. 2. p. 238-243.
46. Detling, J.K., 1988. Grasslands and savannas: regulation of energy flow and nutrient cycling by herbivores. In: L. R. Pomeroy and J. J. Alberts (eds.) *Concepts of Ecosystem Ecology*. Springer-Verlag Inc., New York, NY.
47. Wells, K.L. and C.T. Dougherty. 1997. *Soil Management for Intensive Grazing*. Vol. 18, No. 2. 6 p. Accessed at <<http://www.uky.edu/Agriculture/Agronomy/files/soils/ssvl182.htm>>.
48. Whitehead, D.C. 1995. Nitrogen leaching from soils. In: D.C. Whitehead (ed.) *Grassland Nitrogen*. CAB International, Oxon, UK.
49. Dalrymple, R.L. 1994. Nutrient recycling. *Agricultural News and Views*. Vol. 12, No. 4. p. 3.
50. Wilkinson, S.R. and R.W. Lowrey. 1973. Cycling of mineral nutrients in pasture ecosystems. In: G.W. Butler and R.W. Bailey (eds.) *Chemistry and Biochemistry of Herbage*. Vol. 2. Academic Press. London.
51. Blanchet, K., H. Moechnig, and J. DeJong-Hughes. 1999. *Grazing Systems Planning Guide*. University of Minnesota Extension Service. United States Department of Agriculture. Natural Resources Conservation Service. Accessed at <<http://www.extension.umn.edu/distribution/livestocksystems/DI7606.html>>.
52. Peterson, P.R. and J.R. Gerrish. 1996. Grazing systems and spatial distribution of nutrients in pastures: Livestock management considerations. In: R.E. Joost and C.A. Roberts (eds.) *Nutrient Cycling in Forage Systems*. Potash and Phosphate Institute and Foundation of Agronomic Research. Manhattan, KS.
53. West, C.P., A.P. Mallanrino, W.F. Wedin, and D.B. Marx. 1989. Spatial variability of soil chemical properties in grazed pastures. *Soil Science Society of America Journal*. Vol. 53. No. 3. p. 784-789.
54. Gerrish, J.R., P.R. Peterson, and J.R. Brown. 1994. *Planned Grazing Systems for Sustainable Livestock Production*. Project 9111031-1.
55. Mueller, J.P. and J.T. Green, Jr. 1995. *Controlled grazing. Forage-Livestock Systems*. West Virginia University Extension Service. Accessed at <<http://www.caf.wvu.edu/~forage/controlgrazenc/fctrl.htm>>.
56. Cid, M.S. and M.A. Brizuela. 1998. Heterogeneity in tall fescue pastures created and sustained by cattle grazing. *Journal of Range Management*. Vol. 51. p. 644-649.
57. Forbes, T.D.A. and J. Hodgson. 1985. The reaction of grazing sheep and cattle to the presence of dung from the same or the other species. *Grass and Forage Science*. Vol. 40. p. 177-182.
58. Sharpley, A.N., T. Daniel, T. Sims, J. Lemunyon, R. Stevens, and R. Parry. 1999. *Agricultural Phosphorus and Eutrophication. ARS-149*. United States Department of Agriculture / Agricultural Research Service. Washington, D.C.

59. Voisin, A. 1960. The different actions of various animal species. In: C.T. Herriott (trans.) *Better Grassland Sward*. Crosby Lockwood & Son, London.
60. Bishop-Hurley, G.J. 2000. Growth of pasture plants. In: G. J. Bishop-Hurley, S.A. Hamilton, and R. Kallenbach (eds.) *Missouri Dairy Grazing Manual*. Missouri University Extension. University of Missouri, Columbia, MO.
61. Barnhart, S.K. 1999. How pasture plants grow. Iowa State University. University Extension. Accessed at <<http://www.extension.iastate.edu/Publications/PM1791.pdf>>.
62. Wienhold, B.J., J.R. Hendrickson, and J.F. Karn. 2001. Pasture management influences on soil properties in the northern great plains. *Journal of Soil and Water Conservation*. Vol. 56, No. 1. p. 27-31.
63. Turner, C.L., T.R. Seastdt, and M.I. Dyer. 1993. Maximization of aboveground grassland production: The role of defoliation frequency, intensity, and history. *Ecological Applications*. February. p. 175.
64. Sheath, G.W. and D.A. Clark. 1996. Management of grazing systems: Temperate pastures. In: J. Hodgson and A.W. Illus (eds.) *The Ecology and Management of Grazing Systems*. CAB International. Wallingford, Oxon, UK.
65. Unkovich, M., P. Sandord, J. Pate, and M. Hyder. 1998. Effects of grazing on plant and soil nitrogen relations of pasture-crop rotations. *Australian Journal of Agricultural Research*. Vol. 49. p. 475-85.
66. Aldous, A.E. 1930. Effect of different clipping treatments on the yield and vigor of prairie grass vegetation. *Ecology*. Vol. 11. p. 752-759.
67. Nie, Z.N., A.D. Mackey, I. Valentine, D.J. Barker, and J. Hodgson. 1997. Influence of pastoral fallow on plant root growth and soil physical and chemical characteristics in a hill pasture. *Plant and Soil*. Kluwer Academic Publishers. Netherlands. Vol. 197. p. 201-208.
68. Russelle, M.P. 1996. Nitrogen cycling in pasture systems. In: R.E. Joost and C.A. Roberts (eds.) *Nutrient Cycling in Forage Systems*. Potash and Phosphate Institute and Foundation of Agronomic Research. Manhattan, KS.
69. Henning, J.C. 2001. Managing Pasture Quality. In: T. Terrill and K. Cassida (eds.) *American Forage and Grassland Council Proceedings*. American Grassland Council. Georgetown, TX.
70. Johnson, T.J. 2001. How Four Legumes Respond to Grazing. Accessed at <<http://www.agron.iastate.edu/moore/434/chapter2.htm>> .
71. Weaver, J.E. 1926. Root development of field crops. McGraw-Hill Book Company, Inc., New York. Accessed at <<http://www.soilandhealth.org/01aglibrary/010139fieldcroproots/010139ch14.html>>.
72. Gerrish, J. 2001. Species stability in diverse pasture mixtures. In: T. Terrill and K. Cassida (eds.) *American Forage and Grassland Council Proceedings*. American Grassland Council. Georgetown, TX.
73. Wedin, D.A. 1995. Species, nitrogen, and grassland dynamics: the constraints of stuff. In: C.G. Jones and J.H. Lawton (ed.) *Linking Species & Ecosystems*. Chapman & Hall Inc., New York.
74. Killham, K. 1994. *Soil Ecology*. Cambridge University Press, Cambridge, U.K.
75. Hunt, H.W., D.C. Coleman, E.R. Ingham, R.E. Ingham, E.T. Elliot, J.C. Moore, S.L. Rose, C.P.P. Reid, and C.R. Moreley. 1987. The detrital food web in a shortgrass prairie. *Biology and Fertility of Soils*. Volume 3. p. 57-68.
76. Holter, P. 1979. *Oikos*. Volume 32. p. 393-402.
77. Suckling, F.E.T. 1975. *New Zealand Journal of Experimental Agriculture*. Vol. 3. p. 351-436.
78. Edwards, C. 1999. *Soil Biology Primer*. United States Department of Agriculture, Natural Resources Conservation Service. Washington, D.C.

79. Soil Quality Institute. 2001. Agricultural management effects on earthworm populations. Soil Quality Technical Note No. 11. United States Department of Agriculture. Natural Resources Conservation Service. Soil Quality Institute. Auburn, AL. Accessed at <<http://www.statlab.iastate.edu/survey/SQI/>>.
80. United States Department of Agriculture/ Natural Resources Conservation Service. Rangeland Soil Quality-Soil Biota. Soil Quality Information Sheet. Rangeland Sheet 8. Accessed at <<http://www.statlab.iastate.edu/survey/SQI/range.html>>.
81. Fincher, G.T. 1981. The potential value of dung beetles in pasture ecosystems. *Journal of Georgia Entomological Society*. Vol. 16. 1<sup>st</sup> Supplement. p. 316-333.
82. Richardson, P. Q. and R.H. Richardson. September 1999. Factsheet: Dung beetles (Work for free, love their work). p. 1-3.
83. Knutson, Allen. 2000. Dung beetles— Biological control agents of horn flies. *Texas Biological Control News*. Texas Agricultural Extension Service, Texas A&M University System. Winter 2000.
84. Yeats, G.W. 1981. Nematode populations in relation to soil environmental factors: a review. *Pedobiologia*. Vol. 22. p. 312-338.
85. Elliott, E.T., D.C. Coleman, R.E. Ingham, and J.A. Trofymow. 1984. Carbon and energy flow through microflora and microfauna in the soil subsystem of terrestrial ecosystems. In: M. J. Klug and C. A. Reddy (eds.) *Proceedings of the Third International Symposium on Microbial Ecology*. American Society for Microbiology. Washington, D.C.
86. Soil Quality Institute. Soil Quality-Managing Soil for Today and Tomorrow. Web Page. United States Department of Agriculture, Natural Resources Conservation Service. Accessed at <<http://www.statlab.iastate.edu/survey/SQI/>>.
87. Garlynd, M.J., A.V. Karakov, D.E. Romig, and R.F. Harris. 1994. Descriptive and analytical characterization of soil quality/health. In: J.W. Doran, D.C. Coleman, D.F. Bezdicek, and B.A. Stewart (eds.) *Defining Soil Quality for a Sustainable Environment*. Soil Science Society of America, Inc. Madison, WI.
88. Sullivan, P.G. 2001. Assessing the Pasture Soil Resource. ATTRA. Fayetteville. AR.
89. United States Department of Agriculture/ Natural Resources Conservation Service. Rangeland Soil Quality-Indicators for Assessment and Monitoring. Soil Quality Information Sheet. Rangeland Sheet 2. Accessed at <<http://www.statlab.iastate.edu/survey/SQI/range.html>>.
90. Correll, D.L. 1996. Environmental impact of pasture systems on surface water quality. In: R.E. Joost and C.A. Roberts (eds.) *Nutrient Cycling in Forage Systems*. Potash and Phosphate Institute and Foundation of Agronomic Research, Manhattan, KS.
91. Beegle, D.B., A.N. Sharpley, W.L. Stout, and D.K. Bhumbra. 1998. Water quality and land resource protection: Nutrient and manure management in pasture systems. In: C.R. Krueger (ed.) *Grazing in the Northeast: Assessing Current Technologies, Research Directions, and Education Needs*. Northeast Regional Agricultural Engineering Service. Ithaca, NY.
92. United States Environmental Protection Agency Department of Water. 1999. Laws and Regulations, Policy and Guidance Documents, and Legislation. Web page. Accessed at <<http://www.epa.gov/OW/laws.html>>.
93. Stehman, S.M., C. Rossiter, P. McDonough, and S. Wade. 1996. Potential pathogens in manure. In: J.S. Popow (ed.) *Animal Agriculture and the Environment: Nutrients, Pathogens, and Community Relations*. Northeast Regional Agricultural Engineering Service. Ithaca, NY.
94. Sharpley, A., T.C. Daniel, J.T. Sims, and D.H. Pote. 1996. Determining environmentally sound soil phosphorus levels. *Journal of Soil and Water Conservation*. Vol. 51, No. 2. p. 160-166.
95. Heathwaite, L, A. Sharpley, and W. Gburek. 2000. A conceptual approach for integrating phosphorus and nitrogen management at watershed scales. *Journal of Environmental Quality*. Vol. 29. p. 158-166.

96. Self-Davis, M.L., M.S. Miller, R.L. Raper, and D.W. Reeves. 1996. Pasture soil and vegetation response to renovation tillage. p. 131-136. *In: New technology and conservation tillage. Proceedings of the Southern Conservation Tillage Conference for Sustainable Agriculture.* Jackson, TN. 23-25 July 1996.
97. Cooke, J.G. 1988. Sources and sinks of nutrients in a New Zealand hill pasture catchment: II. Phosphorus. *Hydrology Proceedings.* Vol. 2. p. 123-133.
98. Tate, K.W., G.A. Nader, D.J. Lewis, E.R. Atwil, and J.M. Connor. 2000. Evaluation of buffers to improve the quality of runoff from irrigated pastures. *Journal of Soil and Water Conservation.* Vol. 55, No. 4. p. 473-478.
99. Uusi-Kamppa, J., E. Tutola, H. Hartikainen, and T. Ylaranta. 1997. The interactions of buffer zones and phosphorus runoff. *In: N.E. Haycock, T.P. Burt, K.W.T. Goulding, and G. Pinay (eds.) Buffer Zones: Their Processes and Potential in Water Protection.* Qwest Environmental. Hertfordshire, UK.
100. Mosley, J.C., P.S. Cook, A.J. Griffis, and J. O'Laughlin. 1998. Guidelines for Managing Cattle Grazing in Riparian Areas to Protect Water Quality: Review of Research and Best Management Practices Policy. Accessed at <[http://www.uidaho.edu/cfwr/\[ag/pag15es.html](http://www.uidaho.edu/cfwr/[ag/pag15es.html)>.
101. Clark, E.A. and R.P. Poincelot. 1996. *The Contribution of Managed Grasslands to Sustainable Agriculture in the Great Lakes Basin.* The Haworth Press Inc., New York.
102. Lyons, J., B.M. Weigel, L.K. Paine, and D.J. Undersander. 2000. Influence of intensive rotational grazing on bank erosion, fish habitat quality, and fish communities in southwestern Wisconsin trout streams. *Journal of Soil and Water Conservation.* Vol. 55, No. 3. p. 271-276.
103. Undersander, D. and B. Pillsbury. 1999. *Grazing Streamside Pastures.* University of Wisconsin Extension. Madison, WI.
104. Clary, W.P. and B.F. Webster. 1989. *Managing grazing of riparian areas in the Intermountain Region.* Gen. Tech. Rep. INT-263. Ogden, UT: U.S. Department of Agriculture, Forest Service, Intermountain Research Station.



## Resource List

### AGENCIES AND ORGANIZATIONS

#### **American Forage and Grassland Council.** Gerorgetown, TX.

*Mission statement: "To promote the use of forages as economically and environmentally sound agriculture through education, communication, and professional development of producers, scientists, educators and commercial representatives and through communication with policy makers and consumers in North America" <<http://www.afgc.org>>.*

#### **Grazing Lands Conservation Initiative**

*A national effort to provide high-quality technical assistance on privately owned grazing lands and increase the awareness of the importance of grazing land resources. <<http://www.glci.org/>>.*

*Grazing Lands Technology Institute (GLTI) Provides technical excellence to the Natural Resources Conservation Service (NRCS) and other appropriate customers in the acquisition, development, coordination, and transfer of technology that meets the needs of grazing land resources, landowners and managers, and the public. <<http://www.ncg.nrcs.usda.gov/glti/homepage.html>>, or contact your county or regional NRCS office.*

#### **Cooperative Extension Service.**

*Educational and technical assistance that links farmers and ranchers with university research expertise. Many county or regional offices address grazing practices. To identify your local office see <<http://www.reeusda.gov/1700/statepartners/usa.htm>>.*

#### **Natural Resource, Agriculture, and Engineering Service.** Ithaca, NY.

*Coordinates and publishes proceedings from conferences on agricultural and environmental issues. Also publishes technical and practical documents on manure management, composting, and animal housing. <<http://www.nraes.org>>.*

### General Grazing

Clark, E.A. and R.P. Poincelot. 1996. **The Contribution of Managed Grasslands to Sustainable Agriculture in the Great Lakes Basin.** The Haworth Press Inc., New York.

*An easy-to-read but technically-based discussion of the relations between grazing management, forage production, and soil quality.*

### PUBLICATIONS IN PRINT

Emmick, D.L. and D.G. Fox. 1993. **Prescribed Grazing Management to Improve Pasture Productivity in New York.** United States Department of Agriculture Soil Conservation Service and Cornell University. <<http://www.wscas.cit.cornell.edu/forage/pasture/index.html>>.

Gerrish, J. and C. Roberts (eds.) **1996 Missouri Grazing Manual.** University of Missouri. Columbia, MO.

*Short papers addressing forage production and nutrient management in pastures.*

Pearson, C.J. and R.L. Ison. 1987. **Agronomy of Grassland Systems.** Cambridge University Press. Cambridge.

*Technical discussion of forage biology and production, nutrient availability, and animal nutrition on forages.*

#### **Stockman Grass Farmer Magazine**

*The nation's leading publication on grass-based livestock systems. Order information <<http://stockmangrassfarmer.com/>>.*

Terrill, T. and K. Cassida. 2001. **American Forage and Grassland Council Proceedings.** American Forage and Grassland Council. Georgetown, TX.

Unsander, D., B. Albert, P. Porter, A. Crossley, and N. Martin. No date. **Pastures for Profit. A Guide to Rotational Grazing.** University of Wisconsin Extension. Madison, WI. Available at <<http://www.uwrf.edu/grazing/>>.

### Soil Quality and Soil Conservation

Magdoff, F. and H. van Es. 2000. **Building Soils for Better Crops, Second Edition.** Sustainable Agriculture Network. Handbook Series Book 4. Beltsville, MD.

*Easy-to-read descriptions of concepts regarding soil quality and agricultural management practices to enhance soil quality. Although many of the practical management descriptions are oriented more towards field crops than to grazing systems, the concepts of soil quality protection and management are the same.*

Edwards, C. 1999. **Soil Biology Primer.** United States Department of Agriculture, Natural Resources Conservation Service. Washington, D.C. Order information <[http://www.statlab.iastate.edu/survey/SQI/soil\\_biology.htm](http://www.statlab.iastate.edu/survey/SQI/soil_biology.htm)>

*A well-illustrated overview of soil organisms and their impact on soil quality.*

Cavigelli, M.A., S.R. Deming, L.K. Probyn, and R.R. Harwood (eds). 1998. **Michigan Field Crop Ecology: Managing biological processes for productivity and environmental quality.** MSU Extension Bulletin E-2646. Michigan State University Extension Service, East Lansing, MI.

*A well-illustrated overview of nutrient cycles in agricultural systems, the organisms that affect these systems, and the impact of environmental conditions and management practices on the activities of these organisms.*

### Journal of Soil and Water Conservation.

Technical articles on soil conservation research and practices. Many articles pertain to grazing systems. Order information: <[http://www.swcs.org/f\\_pubs\\_journal.htm](http://www.swcs.org/f_pubs_journal.htm)>

Whitehead, D.C. 2000. **Nutrient Elements in Grassland Soil-Plant-Animal Relationships.** CAB International Publishing. Wallingford, Oxon, UK.

*An excellent technical resource on nutrient cycle components and interactions in grazing systems.*

Undersander, D. and B. Pillsbury. 1999. **Grazing Streamside Pastures.** University of Wisconsin Extension. Madison, WI.

*An easy-to-read overview of the potential risks and benefits associated with riparian grazing practices.*

### Water Quality Protection

Sharpley, A.N., T. Daniel, T. Sims, J. Lemunyon, R. Stevens, and R. Parry. 1999. **Agricultural Phosphorus and Eutrophication.** ARS-149. United State Department of Agriculture / Agricultural Research Service. Washington, D.C. Order information: <<http://www.soil.ncsu.edu/sera17/publicat.htm>>.

*An illustrated, easy-to-read discussion describing the impact of environmental conditions and land management practices on the risk for phosphorus runoff from agricultural lands.*

Daniels, M., T. Daniel, D. Carman, R. Morgan, J. Langston, and K. VanDevender. 1998. **Soil Phosphorus Levels: Concerns and Recommendations.** University of Arkansas. Division of Agriculture. Cooperative Extension Service. Accessed at: <<http://www.soil.ncsu.edu/sera17/publicat.htm>>.

NRAES. 2000. **Managing Nutrients and Pathogens from Animal Agriculture.** Natural Resource, Agriculture, and Engineering Service. Ithaca, NY.

*Proceedings from a conference that included research reports, field experience, and policy discussions. Available from <<http://www.nraes.org>>.*



---

## WEB RESOURCES

---

### Rotational Grazing – University Programs

Center for Grassland Studies - University of Nebraska-Lincoln <<http://www.grassland.unl.edu/index.htm>>.

Purdue Pasture Management Page- Purdue University Cooperative Extension <<http://www.agry.purdue.edu/ext/forages/rotational/>>.

Texas Agricultural Extension Service. Extension Resource Center <<http://texaserc.tamu.edu/catalog/query.cgi?id=433>>.

Controlled Grazing of Virginia's Pastures – Virginia Cooperative Extension <<http://www.ext.vt.edu/pubs/livestock/418-012/418-012.html>>.

Grazing Dairy Systems at the Center for Integrated Agricultural Systems – University of Wisconsin – Madison <<http://www.wisc.edu/cias/research/livestoc.html#grazing>>.

Pasture Management & Grazing – University of Wisconsin Extension <<http://www.uwrf.edu/grazing/>>.

Grasslands Watershed Management – Clemson University <<http://grasslands.clemson.edu/>>.

*Focuses on the role pasture and forage crop production can play in helping insure a clean, safe water supply.*

### Rotational Grazing – Organizations and Agencies

Grazing Lands Conservation Initiative

*A national effort to provide high-quality technical assistance on privately owned grazing lands and increase the awareness of the importance of grazing land resources <<http://www.gpci.org/>>.*

Grazing Lands Technology Institute - Grazing information from the Natural Resources Conservation Service. <<http://www.ncg.nrcs.usda.gov/glti/homepage.html>>.

Stockman Grass Farmer Magazine - The nation's leading publication on grass-based livestock systems <<http://stockmangrassfarmer.com/>>.

American Farmland Trust information site on grass-based farming systems <<http://grassfarmer.com/>>.

Sustainable Farming Connection's Grazing Menu- good links to grazing sites <<http://www.ibiblio.org/farming-connection/grazing/home.htm>>.

Why Grassfed Is Best - Jo Robinson explores the many benefits of grassfed meat, eggs, and dairy products <<http://www.eatwild.com/>>.

Archived listings from Graze-L, an international forum for the discussion of rotational grazing and seasonal dairying <<http://grazel.taranaki.ac.nz/>>.

### Soil Quality

Soil Quality Institute. United States Department of Agriculture. Natural Resources Conservation Service. <<http://www.statlab.iastate.edu/survey/SQI/>>.

*Soil quality information sheets, soil quality indicators, and soil quality assessment methods*

Rangeland Soil Quality. Soil Quality Institute. United States Department of Agriculture Natural Resources Conservation Service. <<http://www.statlab.iastate.edu/survey/SQI/range.html>>.

*Information sheets on rangeland soil quality*

Soil Biological Communities. United States Department of Agriculture Bureau of Land Management. Information sheets. <<http://www.blm.gov/nstc/soil/index.html>>.

Ingham, E. 1996. The soil foodweb: Its importance in ecosystem health. Accessed at <<http://rain.org:80/~sals/ingham.html>>.

The Soil Foodweb Incorporated. <<http://www.soilfoodweb.com/index.html>>.

*Soil microbiology, soil ecology information and laboratory analyses of soil biology.*

SoilFacts. Soil science related publications from North Carolina State University. Includes: Poultry Manure as a Fertilizer Source, Good Soil Management Helps Protect Groundwater, Nitrogen Management and Water Quality, and Soils and Water Quality <<http://ces.soil.ncsu.edu/soilscience/publications/Soilfacts/AG-439-05/>>.

United States Department of Agriculture – Agricultural Research Service. <<http://www.nps.ars.usda.gov/>>.

*Research programs addressing soil and water quality, rangeland, pastures, and forests, and integrated agricultural systems.*

### Water Quality

Pellant, M., P. Shaver, D.A. Pyke, and J.E. Herrick. 2000. Interpreting Indicators of Rangeland Health. Version 3. Technical Reference 1734-6. National Science and Technology Center Information and Communications Group. Denver, CO. <<http://www.ftw.nrcs.usda.gov/glti/pubs.html>>.

SERA-17. Minimizing Phosphorus Losses from Agriculture. <<http://www.soil.ncsu.edu/sera17/publicat.htm>>.

*National, multi-agency information on phosphorus fate and transport, including the development of the phosphorus index.*

United States Environmental Protection Agency Department of Water. 1999. Laws and Regulations, Policy and Guidance Documents, and Legislation. Accessed at: <<http://www.epa.gov/OW/laws.html>>.

Concentrated Animal Feeding Operations (CAFOs) Effluent Guidelines for larger scale farms. <<http://www.epa.gov/ost/guide/cafo/index.html>>.

*Focuses on confinement systems but many of the nutrient management planning guidelines may also be appropriate for grazing systems.*

Animal Feeding Operations. US EPA Office of Water. <[http://cfpub.epa.gov/npdes/home.cfm?program\\_id=7](http://cfpub.epa.gov/npdes/home.cfm?program_id=7)>.

EPA's National Agriculture Compliance Assistance Center. <<http://es.epa.gov/oeca/ag/>>.

*Information on environmental laws affecting agricultural operations.*

### Riparian Grazing

Riparian Grazing Project - University of California Cooperative Extension <[http://www.calcattlemen.org/riparian\\_grazing\\_project.htm](http://www.calcattlemen.org/riparian_grazing_project.htm)>.

Effects of Cattle Grazing in Riparian Areas of the Southwestern United States <<http://www.earlham.edu/~biol/desert/riparian.htm>>.

Managed Grazing and Stream Ecosystems. Laura Paine and John Lyons. <<http://www.uwrf.edu/grazing/>>.

Driscoll, M. and B. Vondracek. 2001. An Annotated Bibliography of Riparian Grazing Publications. The Land Stewardship Project. <<http://www.landstewardshipproject.org/resources-main.html>>.

By **Barbara Bellows**  
NCAT Agriculture Specialist

Edited by **Richard Earles**  
Formatted by **Gail M. Hardy**

**December 2001**

IP136

The electronic version of **Nutrient Cycling in Pastures** is located at:

**HTML**

<http://www.attra.ncat.org/attra-pub/nutrientcycling.html>

**PDF**

<http://www.attra.ncat.org/attra-pub/PDF/nutrientcycling.pdf>



# DUNG BEETLE BENEFITS IN THE PASTURE ECOSYSTEM

CURRENT TOPIC

By Michelle L. Thomas, NCAT Agriculture Intern  
October 2001

## Introduction

Dung beetles play a small but remarkable role in the pasture ecosystem. They feed on manure, use it to provide housing and food for their young, and improve nutrient cycling, soil structure, and forage growth in the meantime. Dung beetles are important enough in manure and nutrient recycling that they well deserve the pasture manager's attention.

Dung beetles belong to the zoological order Coleoptera and family Scarabaeidae. Of the more than 90 species in the U.S., less than a dozen are significant in dung burial. Three behavioral groups of the beetles are relevant to manure recycling. Probably the best-known group are the 'tumble bugs' or 'rollers' (e.g., the species *Canthon pilularius*). In the behavior characteristic of this group, a male-female pair roll a ball of dung (brood ball) away from a manure pile in order to bury it. Dung beetles generally work in pairs.

Another group are the 'tunnelers.' An example of this group is *Onthophagus gazella*, which typically bury the dung balls under the manure pat or close to the edge. Piles of soil next to the dung pat are indicators of tunneler-type dung beetle activity. Collectively, tunnelers and tumbler are classified as 'nesters' because of their behavior in preparing a home for their young. The third group of beetles that use dung are the 'dwellers'. Most dwellers belong to the subfamily Aphodiidae. They live within the manure pat, engage in little to no digging, and generally do not form brood balls.

## Appearance and Behavior

Dung beetles range in size from 2mm (0.1 inch) to 60 mm (2.5 inches). The front legs usually have serrated edges, used for powerful digging. Colors range from black to brown to red, and can have a metallic appearance. Males often have one or two horns. Scarabs are distinguished from other beetles by the appearance of their antennae, which are segmented and end with a plate-like oval club of three to seven expansible leaves. These lobes create a large surface area for detecting odors. Look for these specialized antennae with a magnifying glass.

Adult dung beetles are drawn to manure by odor. Many are species-specific—they prefer a certain type of animal manure. They will fly up to 10 miles in search of just the right dung, and can attack dung pats within seconds after they drop. Some species will even hitch a ride near the tails of animals in anticipation of a deposit. Once drawn by the odor, the adults use the liquid contents of the manure for their nourishment. Dr. Patricia Richardson, Research Associate at the University of Texas, memorably refers to this as a "dung slurpie."

If they are a nesting species, the pair then goes to work on forming a brood ball out of the dung, which contains a large amount of roughage. The pair continue to work as a team to bury the ball.

ATTRA is the national sustainable agriculture information center operated by the National Center for Appropriate Technology under a grant from the Rural Business-Cooperative Service, U.S. Department of Agriculture. These organizations do not recommend or endorse products, companies, or individuals. ATTRA is located in the Ozark Mountains at the University of Arkansas in Fayetteville (P.O. Box 3657, Fayetteville, AR 72702). ATTRA staff members prefer to receive requests for information about sustainable agriculture via the toll-free number 800-346-9140.



The female, which typically has shorter, thicker legs, digs while the male helps haul the soil from the tunnel. The female lays one egg in each ball. She then seals the brood ball, seals the tunnel, and begins the process again if she is of a species that lays several eggs.

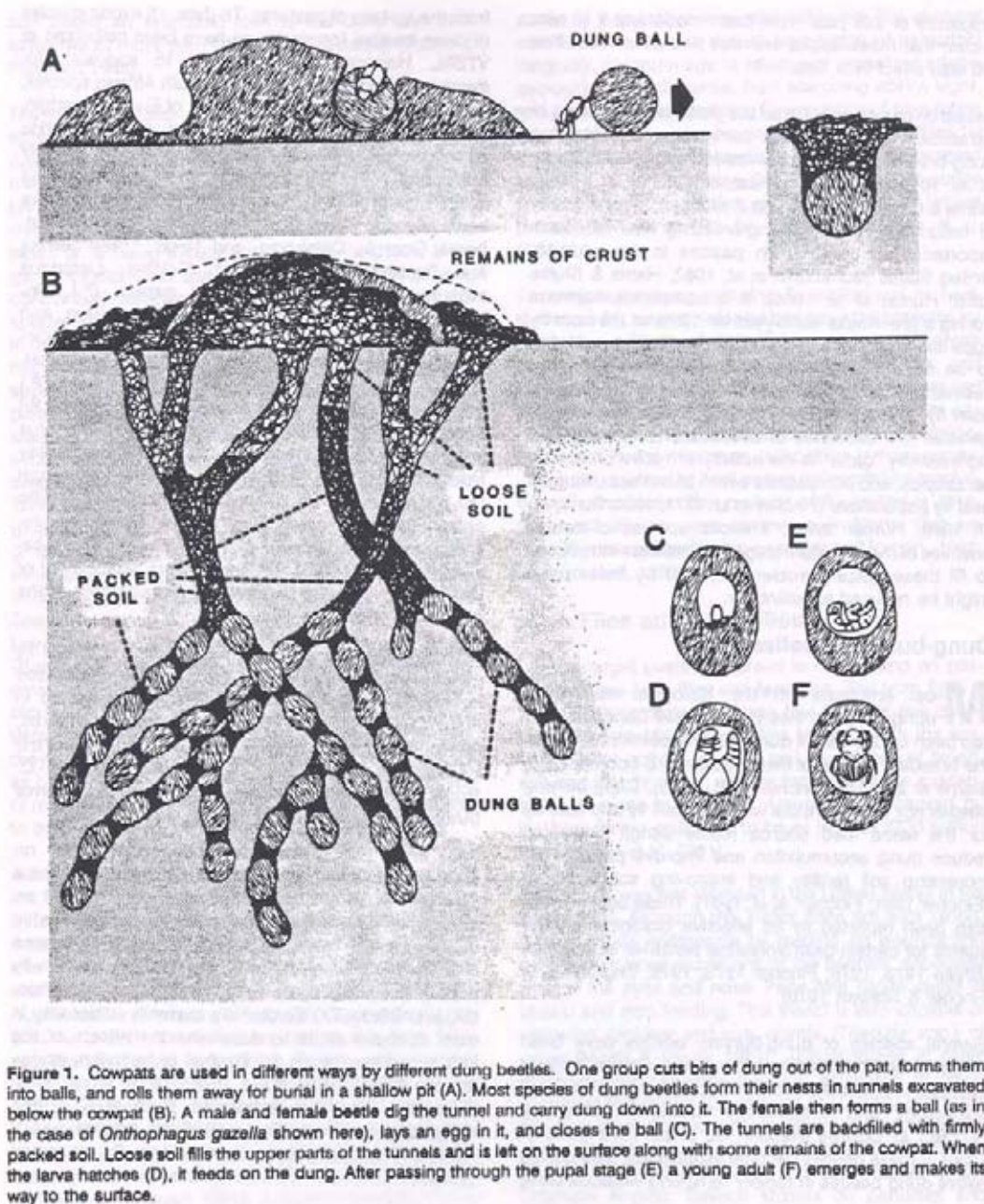

Figure 1. Cowpats are used in different ways by different dung beetles. One group cuts bits of dung out of the pat, forms them into balls, and rolls them away for burial in a shallow pit (A). Most species of dung beetles form their nests in tunnels excavated below the cowpat (B). A male and female beetle dig the tunnel and carry dung down into it. The female then forms a ball (as in the case of *Onthophagus gazella* shown here), lays an egg in it, and closes the ball (C). The tunnels are backfilled with firmly packed soil. Loose soil fills the upper parts of the tunnels and is left on the surface along with some remains of the cowpat. When the larva hatches (D), it feeds on the dung. After passing through the pupal stage (E) a young adult (F) emerges and makes its way to the surface.

Source: Fincher, G.T. and P.B. Morgan. 1990. *Flies affecting livestock and poultry*. p. 152.  
 In: Habeck, et al. (eds.) *Classical Biological Control in the Southern United States*.  
 Southern Cooperative Series Bulletin No. 355. November 1990.

In about a week, the egg hatches within the brood ball. The larva feasts on the interior contents of the ball, eating about 40–50%, and sealing the interior with its own excrement along the way. This

leads to a totally enclosed, protected environment. The larva does not have to compete with others for a food source, and is also protected from predators outside the brood ball. If the integrity of the brood ball is destroyed, the larva will die. Under ideal environmental conditions, the larva will pupate at an average of three weeks. A young adult beetle emerges, eats its way out of the brood ball, forms a new tunnel to crawl out through, and goes on its way in search of fresh manure. The newly emerged beetles will breed two weeks later, with a complete generation taking six weeks under ideal environmental conditions (1).

Soil moisture level is crucial to many species, as breeding and dung burial are decreased in dry periods. During dry weather, the young adults emerge from the brood ball but remain within the soil, waiting for rain. As with most beetles, activity decreases during the coldest months. The larvae remain viable deep within the soil, waiting for environmental cues such as rainfall and temperature to prompt their emergence.

Other dung beetle species prefer an arid climate. *Euoniticellus intermedius*, imported from Australia, is found in south, central, and west Texas where it is especially important ecologically, being active during dry weather when other native beetles are not (2).

## Importing New Species

Dr. Truman Fincher (retired) directed the dung beetle research program at the USDA-ARS Food Animal Protection Research Laboratory at College Station, Texas, until 1998. His research was directed at importing and introducing dung beetle species that would complement and not compete with native populations, in order help balance U.S. pasture ecosystems. According to Fincher, the beetles in the U.S. have not been able to keep up with our increased livestock production and manure waste. Increased fertilizer use and higher-producing forage varieties have boosted forage yields, increasing in turn the animal carrying capacity per unit of pasture. Also, widespread use of insecticides, herbicides, fungicides, and anthelmintics may be responsible for reducing dung beetle populations (3).

If pastures throughout the variety of climates, soil types, and other physical conditions in the U.S. supported Dr. Fincher's ideal complex of dung beetles, manure burial would be ongoing 24 hours a day. Though it may take up to 120 different species of dung beetles to accomplish this goal, the behavioral diversity among species makes it a feasible goal. Some are nighttime flyers, some fly during the day, and some prefer older manure to very fresh. If several species are working together, some may bury the brood ball close to the manure pat, some farther away, some shallow, and some deep (4).

## Benefits to the Pasture System

Dung beetles' benefits to livestock and the pasture environment just might outweigh their somewhat disgusting choice of food. For example, manure is the breeding ground and incubator for horn flies (*Haematobia irritans*) and face flies (*Musca autumnalis*), two economically important pests of cattle. A single manure pat can generate 60–80 horn fly adults if protected from insect predators and competitors such as dung beetles. As dung beetles feed, they compete with the fly larvae for food and physically damage the flies' eggs. Fly populations have been shown to decrease significantly in areas with dung beetle activity. Dr. George Bornemissza found that 95% fewer horn flies emerged from cowpats attacked by *Onthophagus gazella*, than from pats where beetles were excluded (2).

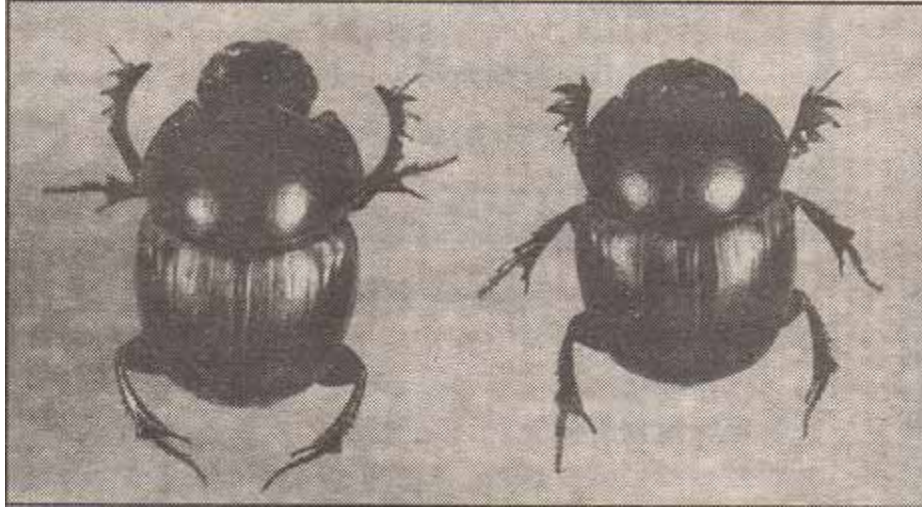

**The Afro-Asian dung beetle, *Onthophagus gazella*, has been successfully established in the southern tier of states, from California to South Carolina. The male is shown at left, the female at right.**

Source: Anon. 1997. *Heroes of the pasture. (Interview with G.T. Fincher.) Acres U.S.A. December. p. 26.*

Dung beetles are also reported to be effective biological control agents for gastrointestinal parasites of livestock. The eggs of most gastrointestinal parasites pass out in the feces of the host. The eggs then hatch into free-living larvae and develop into the infective stage. They then migrate onto grass, where they can be ingested by grazing animals, and complete their life cycle within the animal. If the manure/egg incubator is removed by beetles, the eggs perish and the life cycle of the parasite is broken.

On a pasture-management level, dung pat removal is beneficial for forage availability. Most ruminants will not graze closely to their own species' manure pats. Research has shown that the forage is palatable, but avoided because of the dung pile. Consequently, cattle manure deposits can make from 5% to 10% per acre per year unavailable. By completely and quickly removing the manure, dung beetles can significantly enhance grazing efficiency.

The tunneling behavior of dung beetles increases the soil's capacity to absorb and hold water, and their dung-handling activities enhance soil nutrient cycling. An adequate population and mix of species can remove a complete dung pile from the surface within 24 hours. As the adult dung beetles use the liquid component for nourishment and the roughage for the brood balls, the dung pat quickly disappears. If left on the surface, up to 80% of manure nitrogen is lost through volatilization; by quickly incorporating manure into the soil, dung beetles make more of this nitrogen available for plant use. The larvae use only 40–50% of the brood ball before pupating, leaving behind the remainder of this nutrient-rich organic matter for soil microbes, fungi, and bacteria to use in creating humus (5).

## Management

Dung beetle larvae are susceptible to some insecticides used for fly and internal parasite control for cattle. Ivermectin (Ivomec and Doramectin) injectable, used at the recommended dose, reduced survival of the young of two species for 1 to 2 weeks in a study done by Dr. Fincher. Ivermectin pour-on reduced survival of the larvae for 1 to 3 weeks. Most detrimental was Ivermectin administered as a bolus, with effects lasting up to 20 weeks. Discontinuing the use of this type of insecticide will help increase your population of dung beetles.

Specific chemicals aside, one must consider that any product designed to harm, limit, or kill would have some impact on the ecosystem in general, and should be used judiciously. Backrubbers, ear tags, and the *occasional* use of insecticide dusts and sprays are alternatives that have little or no effect on dung beetles (2). Another option is to treat cattle during the coolest months of the year, as the beetles and larvae are inactive at those times. Better yet, before treating your animals for internal parasites, take a fecal sample to your veterinarian. An egg count can help determine parasite load and whether the symptoms you may be seeing in the form of low gains, weight loss, unthriftiness, etc., are truly being caused by parasites.

Controlled grazing systems increase dung beetle populations and varieties by concentrating the manure in smaller areas, thus reducing the time beetles must spend in search of food. Grazing cycles that match the reproductive cycle of the beetles are favorable, as cattle return to grazing cells at the same time that new adults are emerging from the soil. For more information on controlled grazing systems, refer to the ATTRA publications *Rotational Grazing* and *Sustainable Pasture Management*.

Watch the length of time it takes for the manure pats to disappear in your pasture. If they remain intact for more than a few days, chances are your dung beetle population is low to non-existent. Look for hole formation in the surface of the manure pats. Many types of beetle and other insects also help to desiccate the pats. Management is the key to increasing the number and variety of dung beetles and other beneficial insects.

Dung beetles are just one small part of the pasture ecosystem, but too important to ignore. To summarize the dung beetle benefits highlighted by Dr. Fincher:

- Increased pasture yields resulting from the incorporation of organic matter into the soil with an increase in soil friability, aeration, and water holding capacity
- Reduction of other insect pest populations that breed in animal feces
- Prevention of pasture surface pollution
- Reduction of animal diseases by removing contaminated feces from pasture surfaces
- Return to the soil of nutrients that would otherwise be tied up in fecal deposits and unavailable to pasture grasses
- Increased effective grazing areas of pastures covered by feces
- Reduced nitrogen loss in livestock feces

## On a Personal Note...

My interest in this research area was sparked by observations made during our local grazing group's pasture walks, held monthly in the Northwest Arkansas area. While walking through the pastures, you have to carefully watch your step to avoid those proverbial 'pats.' As the warm spring days arrived, we noticed holes on top of the manure pats, and began to investigate further. Seeing various small beetles, spiders, flies, gnats, and other insects led to more investigation.

Some in the group were more investigative than others, using pocketknives and sticks to plow into the manure. We found dry, hard shells with holes on the outside, and tunnels with moisture underneath. Some of the shells were simply that—shells with hollow interiors. Many pats were spread out, with only a bit of roughage left behind. Several had piles of soil next to the edge of the pat. Having learned about dung beetles and their benefits from veterinarian and ATTRA Specialist Dr. Ann Wells, the group had some ideas about what we were looking at. And as usual, we also had more questions. My curiosity piqued, I began to research the subject during my summer internship. I have since had the opportunity of watching the seasonal changes on the dung scene from late spring, through summer, and into early fall.

Research in the scientific literature was also interesting, but I finally turned to a few experts for the benefit of their applied knowledge. Dr. Patricia Richardson has written several publications on this topic, with a humorous style I admire. When I came across mention of a dung beetle 'farm' used at a workshop in Texas, I decided to try to replicate it for myself. Dr. Richardson very helpfully provided construction details.

Next, I needed the 'workhorse' of all the tunneler dung beetles, the *Onthophagus gazella*. Again I called on Dr. Richardson for advice on how to locate them near my home in the Arkansas River Valley. She suggested watching at dusk and at dawn, as they are nighttime flyers. For several evenings and early mornings I followed her suggestions, to no avail. (I did see three beautiful 'rainbow scarabs' around a pat by flashlight late one evening.) Frustrated, I went to Plan B: I scooped up an entire manure pat with the telltale sign of tunneler activity, a fresh soil mound, next to it—and bagged and froze it. I dissected the pat the next afternoon, sorting out beetles by size and appearance into separate containers, and made a trip to the University of Arkansas Entomology Museum, where Dr. Jeffrey Barnes identified my beetles for me. To my utter dismay (devastation may be a better word), there were no Scarabs, or "true dung beetles." Most of my specimens were of the Histeridae family, which is another very beneficial beetle, but not what I was looking for. Finally I turned to Oklahoma cattleman Walt Davis, who graciously sent several of the *gazella* beetles to me by mail.

I filled the "farm" with sandy soil from the river bottom, and put fresh cattle manure on top. The looming challenge now was to distinguish the males from the females, in order to place two or three pairs into the farm. With Dr. Richardson's notes close at hand, I placed one beetle into a white coffee cup for close viewing. The front legs were serrated as she described, and the antennae had little lobes on the end. Males have two small horns that lie toward the back and are a little difficult to see at first. The females have shorter, thicker legs than the males, and no horns. (I must admit I have become quick at sex identification of these creatures, which is alarmingly rewarding.) I placed two pairs into the farm and waited.

Within three days, we began to see tunnels forming. I added another pair and the brood balls became visible within a few more days. I cannot adequately describe my excitement. After two weeks, at least 38 brood balls were present, indicating time to entice the parents out of the nest. Dr.



Richardson suggested 'starving' them out for a few days, then luring them into a new, fresh pile of manure. The process worked very well.

At this point, I am watching the brood balls for movement and hatching, approximately 4 weeks after their burial. I have seen two larvae moving and eating, and hope they will consider the sheet of Plexiglas an integral part of the brood ball for later pupation. The weather, however, will have an effect since it is cooling off below 55 degrees Fahrenheit at night. This will slow their activity, and, from my understanding, may even arrest their emergence until the warm spring evenings and rainfall begin. Even so, this dung beetle farm can be used for presentations and educational opportunities for several months and that is my intention.

One last note of excitement over this project: I located several dung beetles I believe to be *gazellas* while cleaning the poultry pens at our county fair in September, after a long, much-needed rain. Moisture is critical to their activity, and they showed up when and where I least expected! We have since found these tunnelers on our own farm as well, and they are most welcome to stay as long as they will.



## Dung Beetle Life Cycle Viewing Chamber

You can easily build your own dung beetle farm for observation of burrows, brood balls, larvae, etc. This would make a great school or 4H project for the kids. The chamber consists of two plexiglass sides with a 1/2" space between them held in a wooden frame, with a viewing area (per side) of about 24" wide by 20" tall. Information provided by Dr. G. Truman Fincher via Dr. Patricia Richardson.

### **Lumber needed:** (use treated lumber)

Bottom: (2" x 4") 31" long. Cut a "generous" 7/8"-wide, 1/2"-deep center groove down the entire length of the board.

Sides: make 2—(2" x 2") 21" long. Again, cut a "generous" 7/8"-wide, 1/2"-deep center groove the entire length of the board. At the bottom end of each side piece, cut the board to leave a 1/2"-deep, 7/8" wide tongue to fit into the groove in the bottom piece.

Braces: make 2—(2" x 4") On the outside of each side piece is a wedge-shaped brace about 4" tall, glued to the side and screwed to the bottom.

Top: (1" x 2") 20" long. Cut a "generous" 7/8"-wide, 1/4"-deep center groove the entire length of the board. Make a 16"-long cut (the thickness of the saw blade) *through the board*, in the center of the groove and the middle of the board's length—this is the air slit.

### **Plexiglass needed:**

2 viewing sides: 3/16" thick, 25" wide by 21" tall

2 end strips: 1/2"-thick, 1/2" wide by 20.5" tall

1 bottom strip: 1/2" thick, 1/2" wide by 25" long

3 support circles (or squares, or triangles): 1/2" thick, about the diameter of a quarter, to keep the viewing sides from bowing in or out.

Glue all strips and circles to one of the plexiglass viewing sides. Place one circle in the center, about 16" from the bottom. Place the other two about 6" in from either side and 8" up from the bottom.

When the chamber is assembled, drill a hole through each support circle (in through one plexiglass side and out the other). Secure with bolts and nuts. Glue and screw wood frame pieces into place.

Add sandy loam soil up to about 7" from the top, fresh cow manure (big blob piled in middle), and two or three male/female pairs of adult dung beetles. Keep at warm temperature (they like 85 degrees F). They should begin to burrow and make brood balls within a day or two. Add more fresh manure as needed. Remove the adult dung beetles in a week to ten days (withhold fresh manure for a while, then lure them into a bucket of fresh). Provide 14 hours of light, 10 of darkness.

### **References:**

- 1) Richardson, Patricia Q. and R.H. (Dick) Richardson. 2000. Dung beetles improve the soil community (Texas/Oklahoma). *Ecological Restoration*. Summer. Vol. 18, No. 2. p. 116–117.
- 2) Knutson, Allen. 2000. Dung beetles—Biological control agents of horn flies. *Texas Biological Control News*. Winter. Texas Agricultural Extension Service. The Texas A&M University System.
- 3) Habeck, D.H., F.D. Bennett, and J.H. Frank (eds.) November 1990. Classical biological control in the southern United States. *Southern Cooperative Series Bulletin* No. 355.
- 4) Fincher, G.T. 1981. The potential value of dung beetles in pasture ecosystems. *J. Georgia Entomol. Soc.* Vol. 16. 1<sup>st</sup> Supplement. p. 316–333.

- 5) Richardson, Patricia Q. and R.H. (Dick) Richardson. September 1999. Factsheet: Dung beetles (Work for free, love their work). p. 1–3.
- 6) Behrens, Patricia W. 1994. Dung beetles: Beetlemania in action. Acres U.S.A., October. Vol. 24, No. 10. p. 10–12

### **Another Source of Information:**

Floate, Kevin. 2001. Lethbridge Research Centre. Agriculture and Agri-Food Canada Research Branch. Accessed 6 June, 2001:

*Biological Control of Insect Pests: Insects in Cattle Dung*  
[http://res2.agr.ca/lethbridge/scitech/kdf/dungbugs-bousier\\_e.htm](http://res2.agr.ca/lethbridge/scitech/kdf/dungbugs-bousier_e.htm)

The Electronic version of **Dung Beetle Benefits in the Pasture Ecosystem** is located at:  
**HTML**  
[www.attra.org/attra-pub/dungbeetle.html](http://www.attra.org/attra-pub/dungbeetle.html).  
**PDF**  
[www.attra.org/attra-pub/PDF/dungbeetle.pdf](http://www.attra.org/attra-pub/PDF/dungbeetle.pdf)

Would you give us  
some feedback on  
this publication



# Feedback

1. Does this publication provide the information you were looking for?  
How could it be improved?
2. Do you know a farmer who is implementing techniques discussed in this publication? Can you provide their address and phone number?
3. Do you know of any related research that would add to the information presented here?
4. Do you know a good related website not listed in this publication?
5. Please add any other information, or comments that you wish to share.

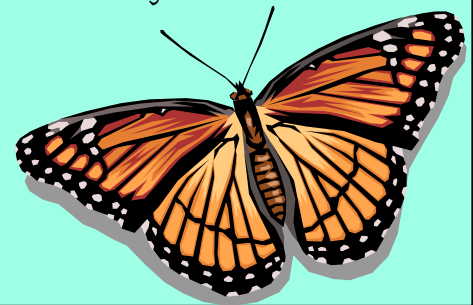

NCAT/ATTRA  
PO Box 3657  
Fayetteville, AR 72702

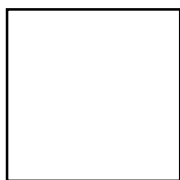

# Assessment of Plant and Soil Resources

## Additional Resources

### Web sites

#### **NRCS**

[www.nrcs.usda.gov](http://www.nrcs.usda.gov)

#### **ARS Range Monitoring Manuals**

[http://usda-ars.nmsu.edu/monit\\_assess/index.html](http://usda-ars.nmsu.edu/monit_assess/index.html)

#### **Interpreting Indicators of Rangeland Health**

[ftp://ftp-fc.sc.egov.usda.gov/GLTI/technical/publications/IIRH\\_v4\\_8-15-05.pdf](ftp://ftp-fc.sc.egov.usda.gov/GLTI/technical/publications/IIRH_v4_8-15-05.pdf)

#### **USDA Pasture Condition Score System**

<http://ddr.nal.usda.gov/bitstream/10113/37920/1/IND44315660.pdf>

#### **Guide to NRCS Pasture Condition Scoring**

<ftp://ftp-fc.sc.egov.usda.gov/GLTI/technical/publications/pasture-score-guide.pdf>

#### **Pasture Condition Score Sheet**

<ftp://ftp-fc.sc.egov.usda.gov/GLTI/technical/publications/pasture-score-sheet.pdf>

# Animal Resources



In this section:

- *An Illustrated Guide to Sheep and Goat Production*
- *Goats: Sustainable Production Overview*
- *Meat Goats: Sustainable Production*
- *Dairy Goats: Sustainable Production*
- *Sheep: Sustainable and Organic Production*
- *Dairy Sheep*
- *Breeds and Production Traits of Meat Goats*
- *Additional Resources*





An Illustrated Guide to



# Sheep and Goat Production

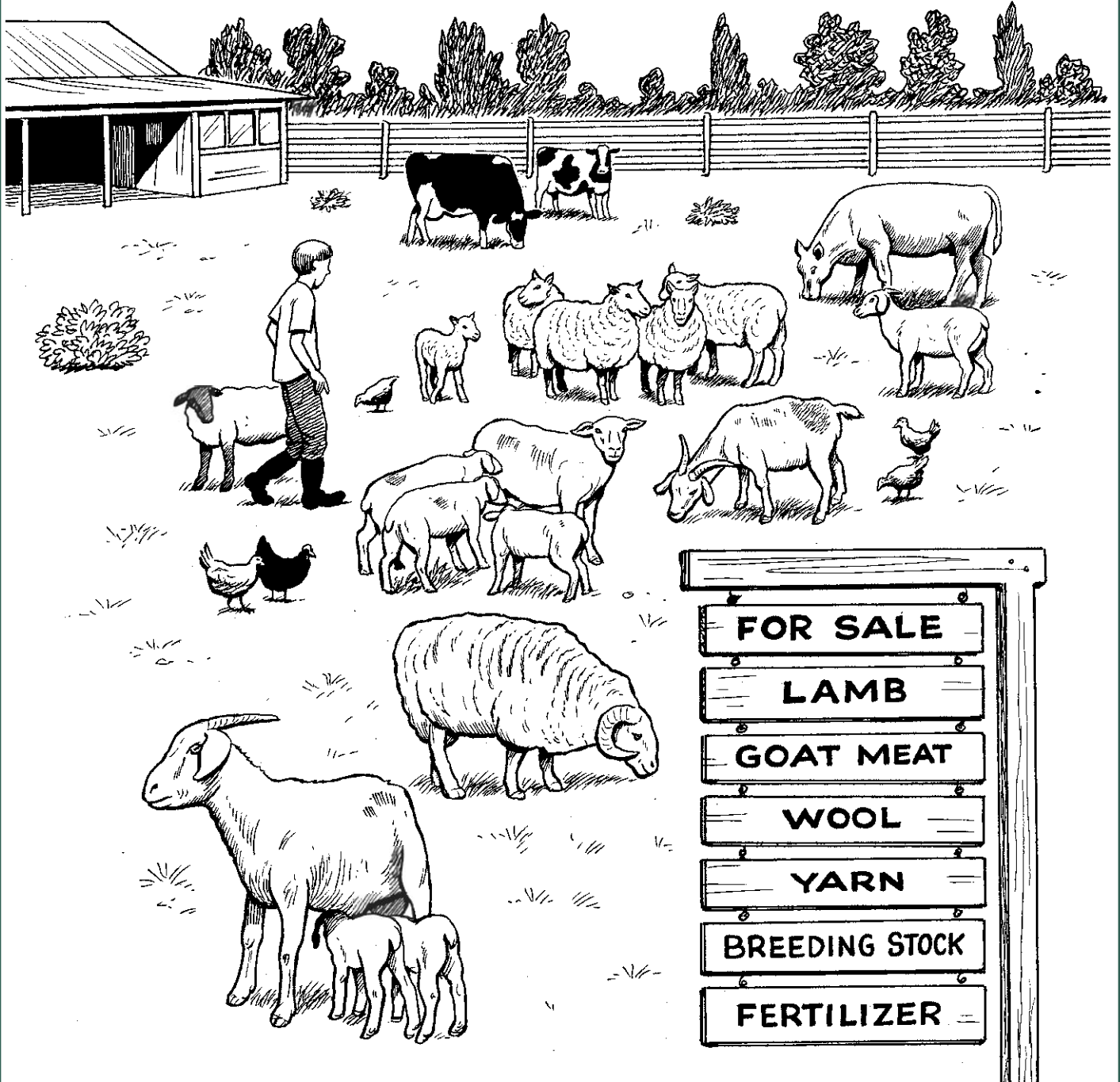

A Publication of ATTRA - National Sustainable Agriculture Information Service • 1-800-346-9140 • [www.attra.ncat.org](http://www.attra.ncat.org)

ATTRA—National Sustainable Agriculture Information Service is managed by the National Center for Appropriate Technology (NCAT) and is funded under a grant from the United States Department of Agriculture's Rural Business-Cooperative Service. Visit the NCAT Web site ([www.ncat.org/sarc\\_current.php](http://www.ncat.org/sarc_current.php)) for more information on our sustainable agriculture projects.

Funding for the development of this publication was provided by the USDA Risk Management Agency.



## Contents

Selection.....	3
Feeding and Pasture.....	5
Breeding and Young Stock .....	8
Health .....	12
Equipment and Handling .....	15
Marketing.....	16
Conclusion.....	18
Resources .....	18

## Related ATTRA Publications

- Goats: Sustainable Production Overview
- Meat Goats: Sustainable Production
- Dairy Goats: Sustainable Production
- Sustainable Sheep Production
- Dairy Sheep
- Small Ruminant Sustainability Checksheet
- Managing Internal Parasites in Sheep and Goats
- Pasture, Rangeland and Grazing Management
- Ruminant Nutrition for Graziers

## INTRODUCTION

Sheep and goats are versatile animals and can be valuable and enjoyable additions to many farms.

### MILK

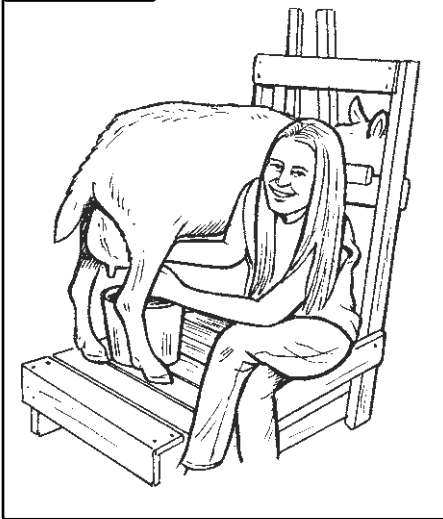

### BRUSH CONTROL



### MEAT

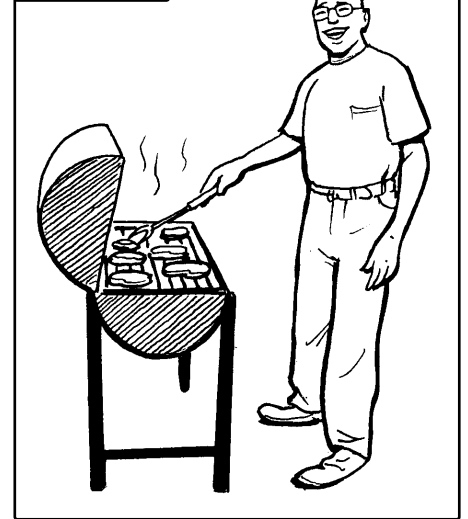

### FIBER



### PASTURE AND RANGE IMPROVEMENT

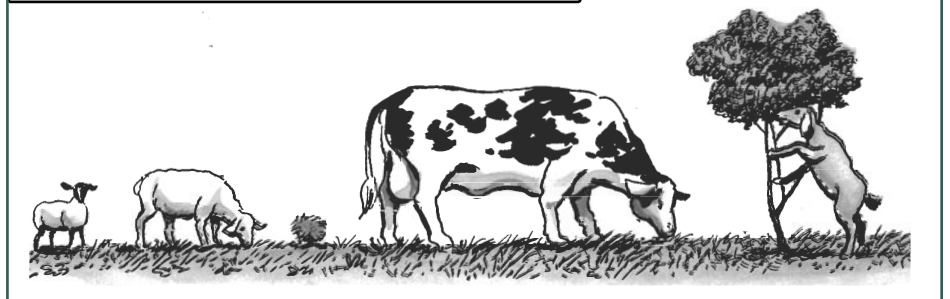

Following are some things you need to know before adding sheep or goats to your farm.

# SELECTION

Your sheep or goat business will be much more enjoyable and successful if you begin with healthy animals with proper conformation. These are characteristics you should look for when selecting stock.

## GOOD GOAT CONFORMATION

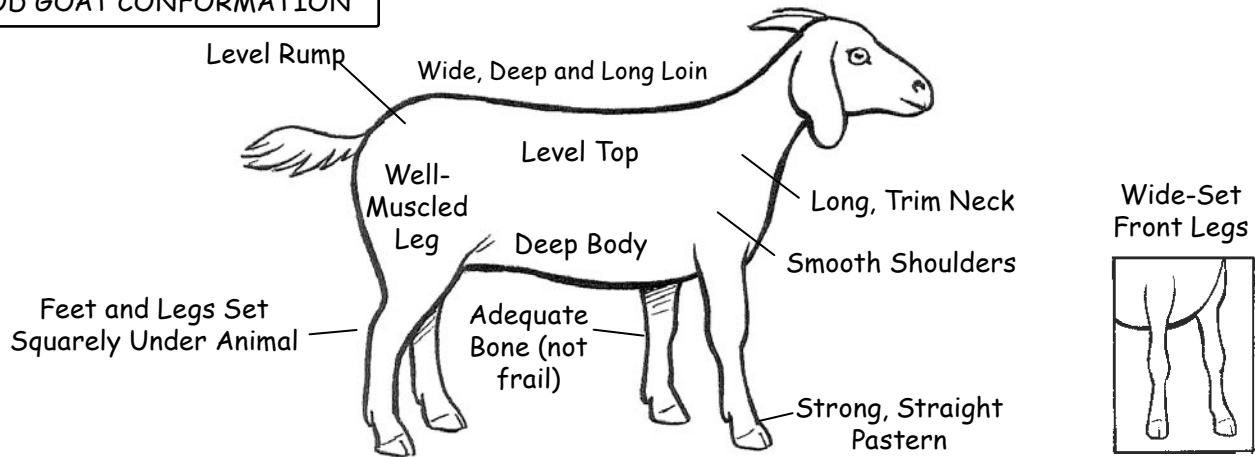

## GOOD SHEEP CONFORMATION

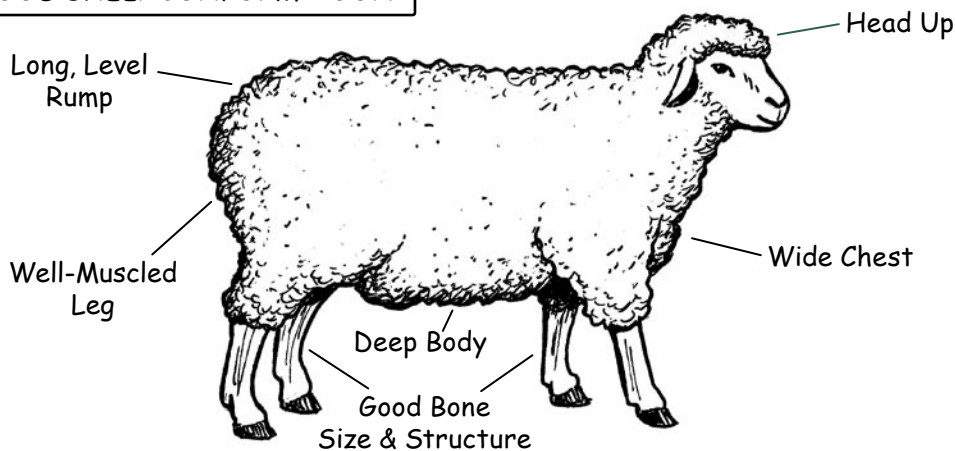

Animals with good conformation are:

- Strong in structure
- Deep bodied
- Wide chested
- Able to walk squarely on feet and legs

Animals in good health are:

- Robust
- Alert
- Bright eyed
- Lively

Healthy goats are shiny with a smooth coat and are free of abscesses.

## AVOID ANIMALS WITH SIGNS OF POOR HEALTH

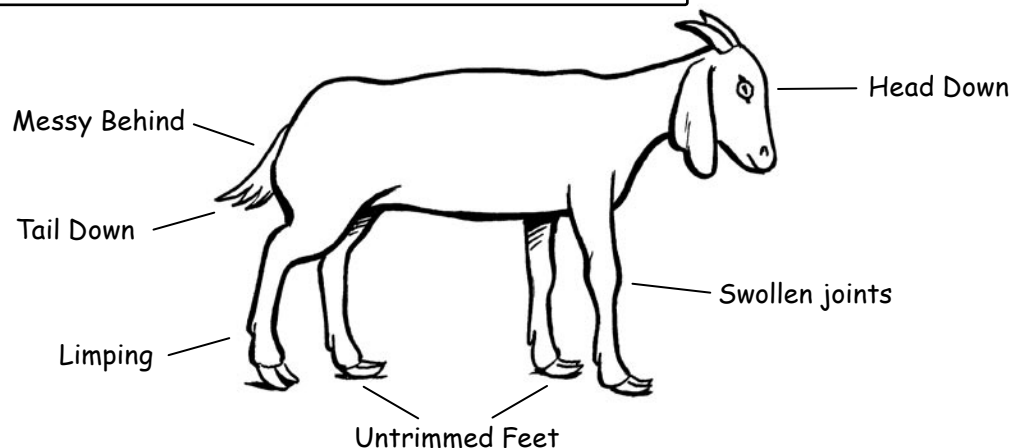

Does and ewes should have a well-balanced udder with two functional teats.

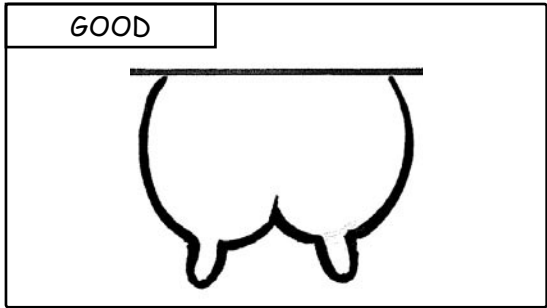
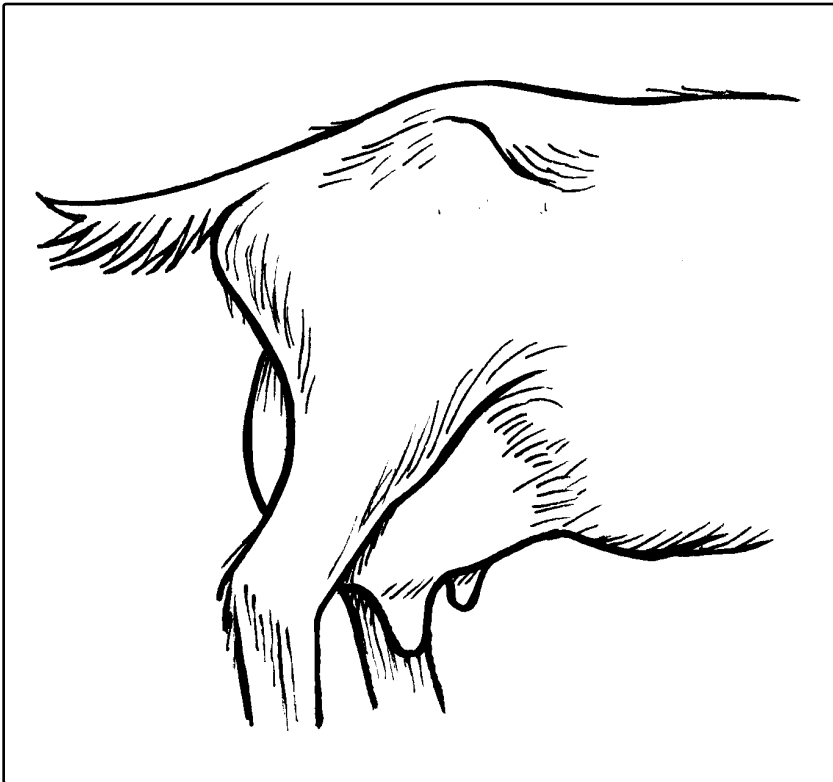

Avoid animals with really small or really large teats. Other udders to avoid:

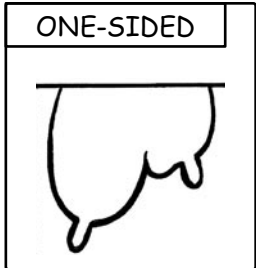
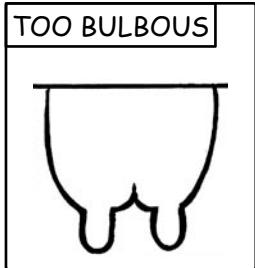

Select animals with good teeth and a proper bite. You can determine an animal's age by looking at its teeth.

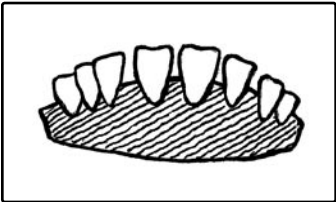

MILK TEETH (Baby Teeth): Less than 1 year of age

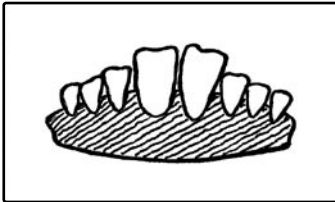

2 ADULT TEETH: 1 Year

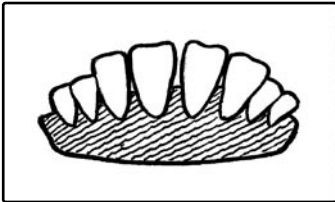

4 ADULT TEETH: 2 years

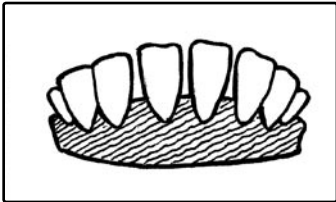

6 ADULT TEETH: 3 years

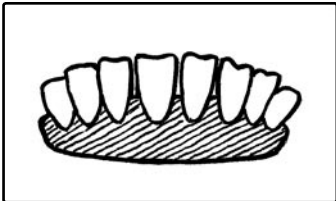

ALL 8 ADULT TEETH: 4 years

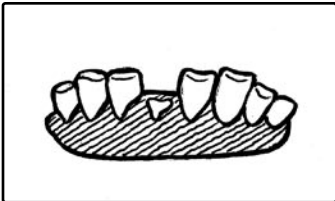

WORN MOUTH or BROKEN MOUTH: Over 5 years of age

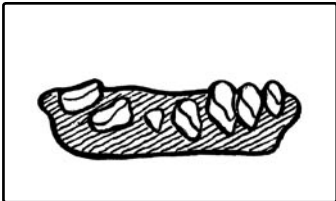

GUMMY: Aged

# FEEDING AND PASTURE

- Goats prefer to browse, or eat things such as brush, leaves, and small trees.
- Sheep prefer to eat broadleaf plants (forbs) and grasses.
- Sheep and goats are able to select the most nutritious parts of a plant.

SHEEP GRAZING

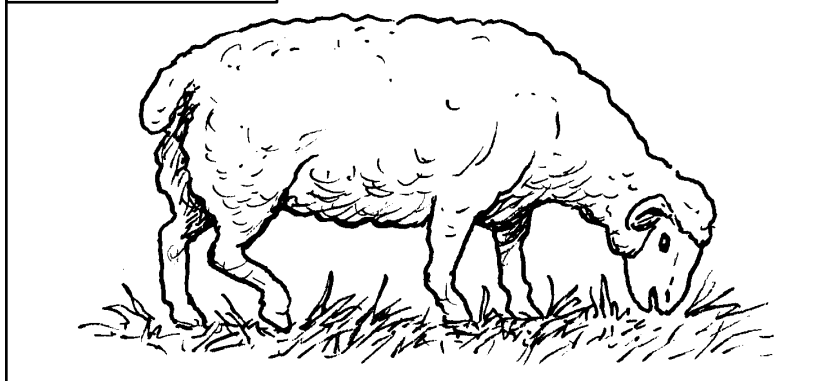

GOAT BROWSING



DIVERSE, HEALTHY PASTURE

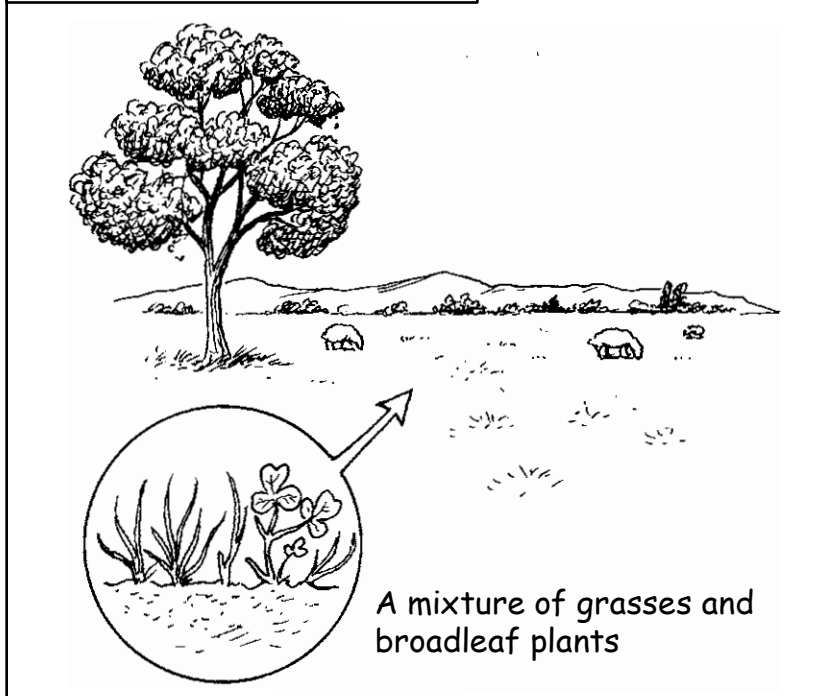

- Sheep and goats like to have a variety of forages to choose from.
- If you provide diverse forages to your animals, they are able to select a diet that meets their nutritional needs.
- It is important to always provide a clean water supply and fresh minerals.

Maintain proper forage height; don't let your animals graze forage under two inches.

OVERGRAZED



SPOT GRAZED

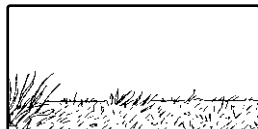

TOO SHORT



JUST RIGHT

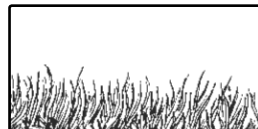

TOO TALL



**FEEDING AND PASTURE** *continued*

- Proper fencing is necessary for sheep and goat production. You must have adequate fencing in place before getting animals!
- There are many options to keep animals in and predators out.

**WOVEN WIRE WITH BARBED WIRE**

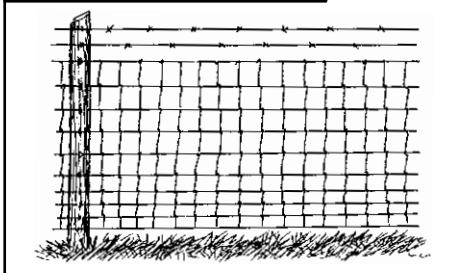

**MULTIPLE STRANDS OF BARBED WIRE**

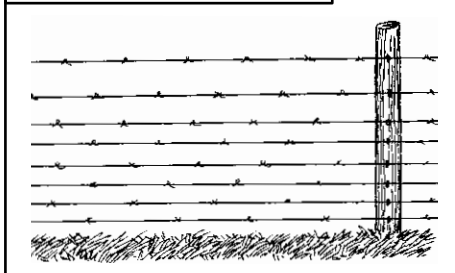

**PORTABLE ELECTRIC NET FENCING**

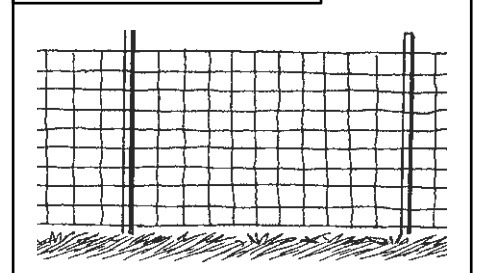

**OFF-SET ELECTRIC FENCE**

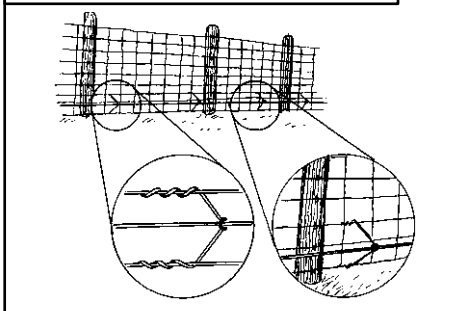

**FIVE STRANDS OF ELECTRIC WIRE**

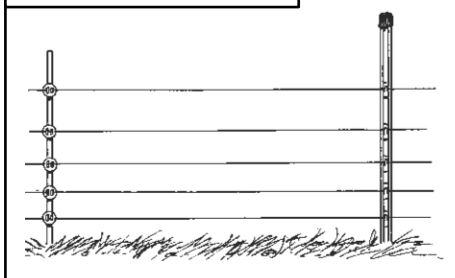

**MULTIPLE STRANDS OF ELECTRIC POLYTAPE**

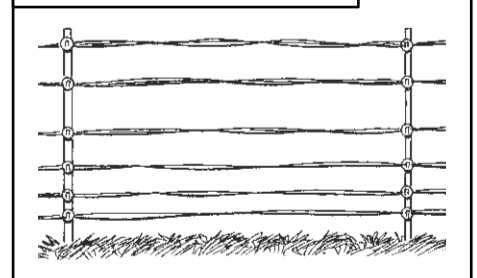

There are many methods for dealing with potential predators.

**GUARDIAN DOG**

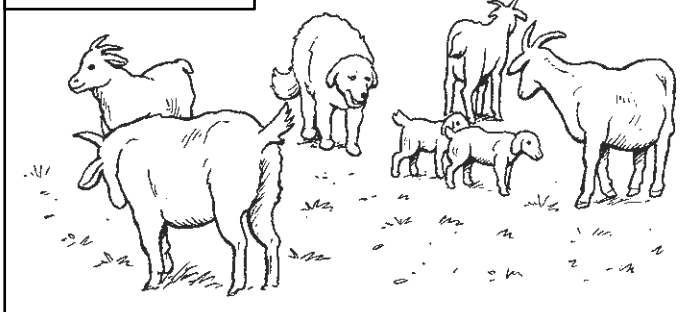

**DONKEY**

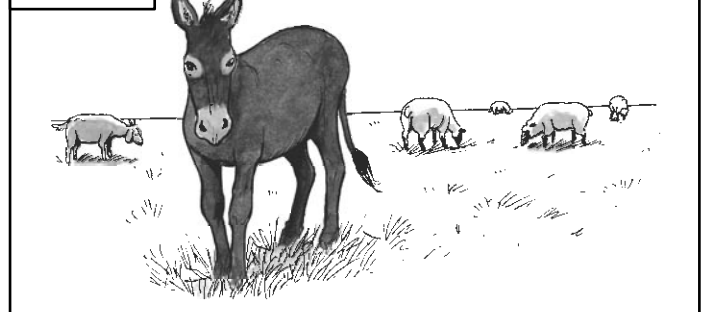

**LLAMA**

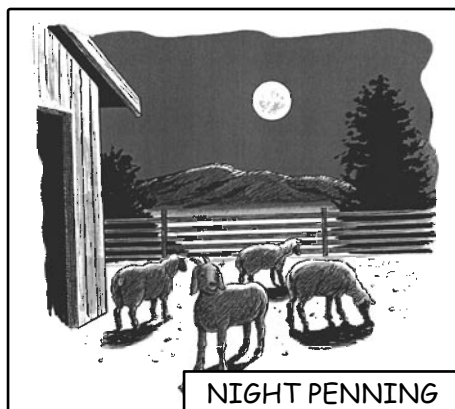
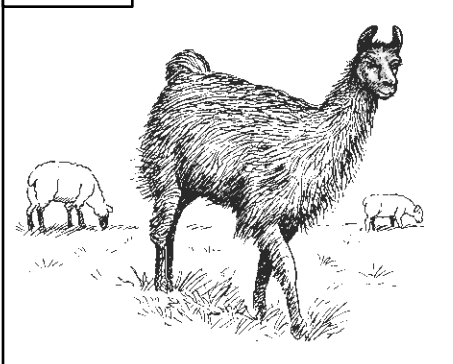

**NIGHT PENNING**

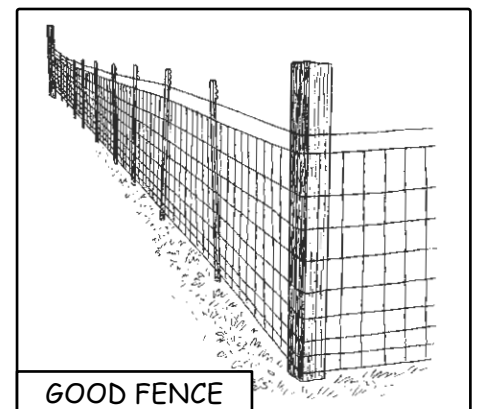

**GOOD FENCE**

**FEEDING AND PASTURE** *continued*

- Allow pastures and forages a time to rest after periods of grazing.
- Having multiple pastures or paddocks (see below) to rotate animals through will use forages more efficiently. Use a combination of permanent and portable fencing to subdivide paddocks. Numbers indicate possible number of paddocks and grazing sequence.

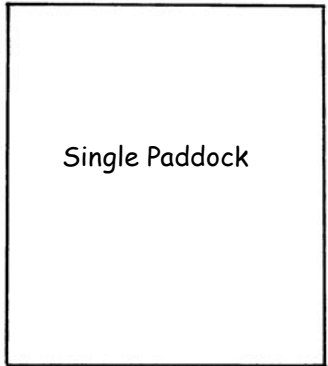

CONTINUOUS  
GRAZING

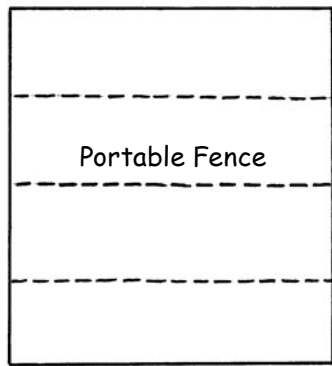

STRIP GRAZING

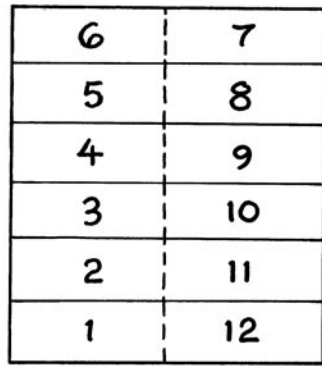

ROTATIONAL  
GRAZING

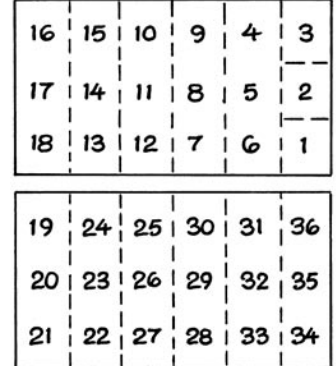

INTENSIVE  
ROTATIONAL GRAZING

- Sheep, goats, and cattle have different forage preferences. The animals won't compete for food, and pastures will be evenly grazed.
- You can run different species together, or you can follow one species with another in a rotation.

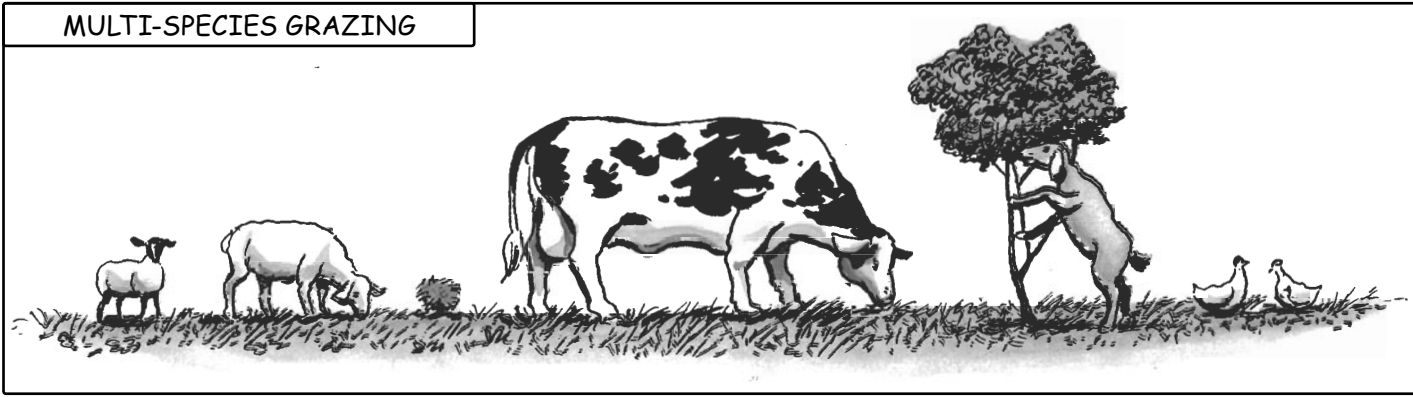

It is important to manage forages so that animals maintain proper body condition. You don't want your animals too fat or too thin. Look at spine, hip bones, ribs, and legs.



TOO THIN



THIN



SATISFACTORY



SATISFACTORY  
BUT TENDING  
TOWARDS FAT

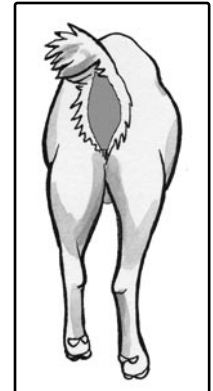

TOO FAT

- Occasionally hay or grain will have to be fed. Use proper feeders to keep feed clean and off of the ground.
- Use a hay feeder to reduce waste.
- There are various options for feeders.

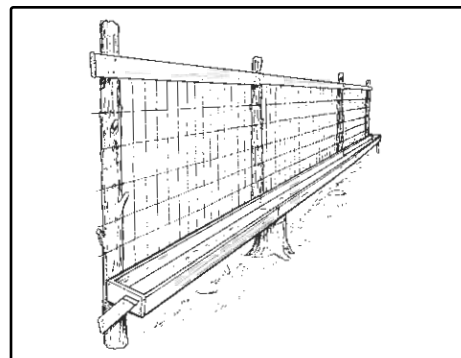
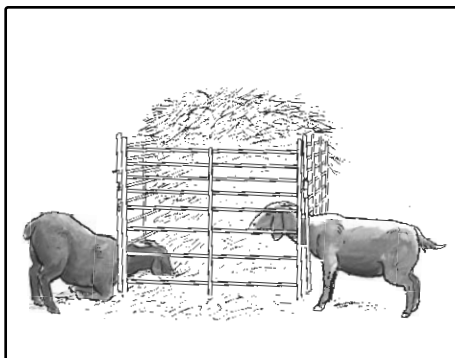
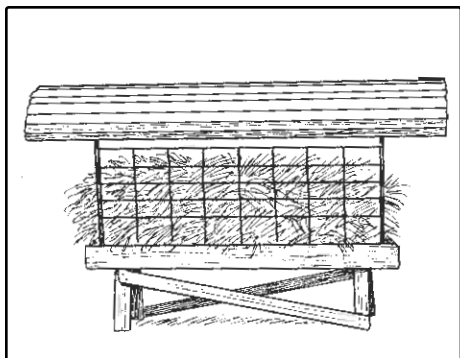
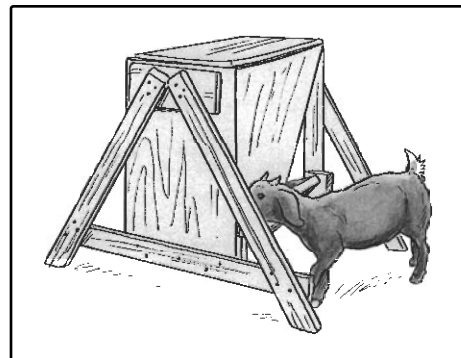
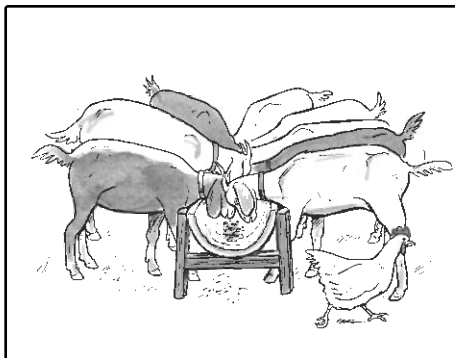
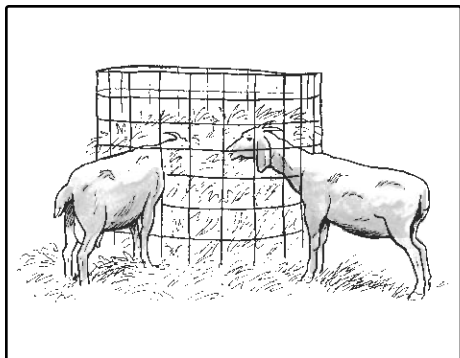
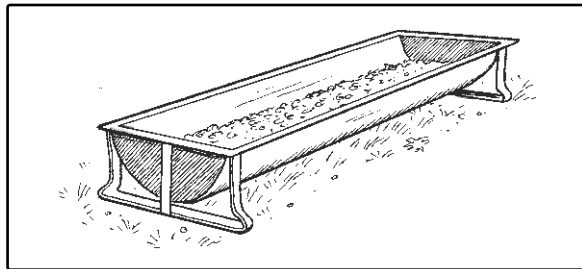

## BREEDING AND YOUNG STOCK

The foundation of your herd is the herd sire. It is worth spending money and attention on a good buck or ram.

Selection considerations:

- Fertility
- Health and hardiness
- Adaptation to environment and management
- Internal parasite resistance
- Body type
- Marketing goals

### MEAT GOAT BUCK

Use caution when handling bucks and rams, and never treat them as pets.

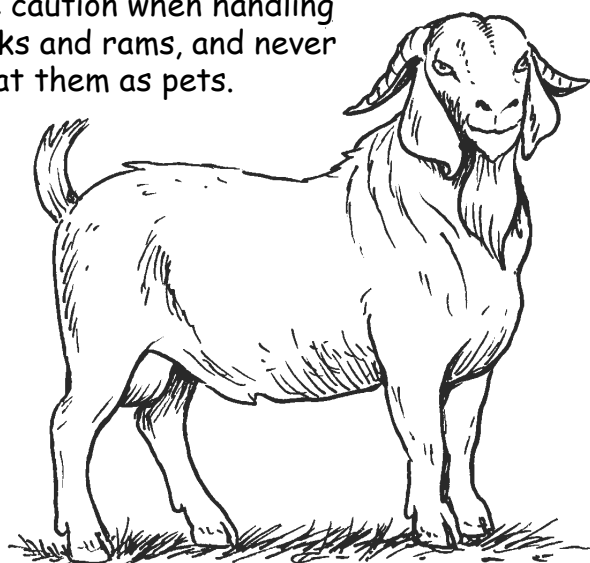



**BREEDING AND YOUNG STOCK** *continued*

If ewes and does are at least 3/4 of their adult size, they can lamb or kid at one year of age.

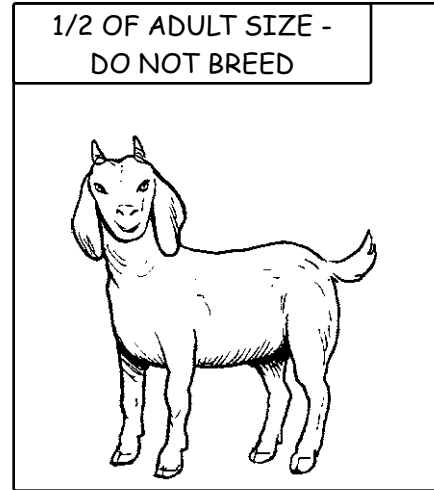
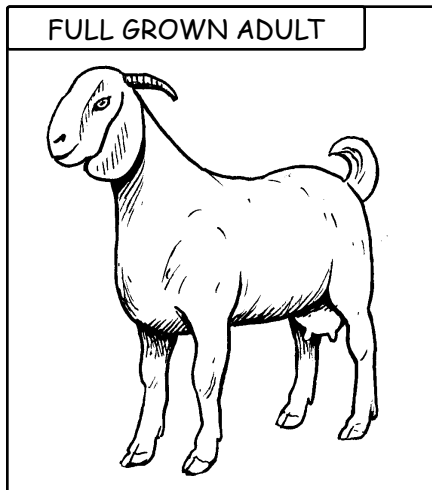

The usual breeding season is August to January. Kids and lambs will arrive five months after breeding.

Turn the buck or ram with the females five months before you want the kids or lambs to be born. Watch the herd or flock and note breeding activity.

CALCULATING DUE DATES	
date BRED	date DUE
Jan. 1	May 31
Feb. 10	July 10
Mar. 2	July 30
Apr. 1	Aug. 29
May 1	Sept. 28
June 30	Nov. 27
July 30	Dec. 27
Aug. 29	Jan. 26
Sept. 28	Feb. 25
Oct. 28	Mar. 27
Nov. 27	Apr. 26
Dec. 27	May 26

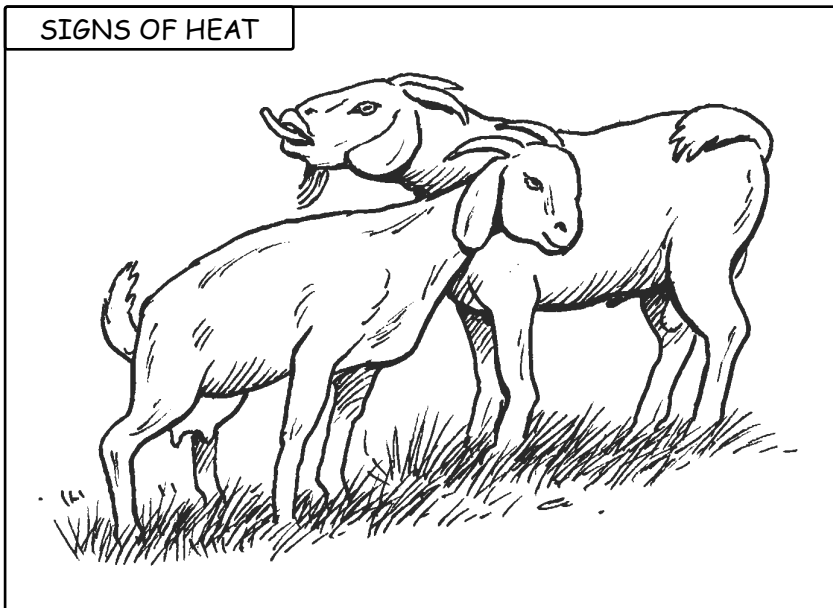

Records are useful for decision-making. Here is an example of a kidding record.

KIDDING						
Animal ID	Bred	Due	Kidded	No. in Litter	Sire	Comments

This is how a kid or lamb is normally born. It usually takes about an hour of labor.

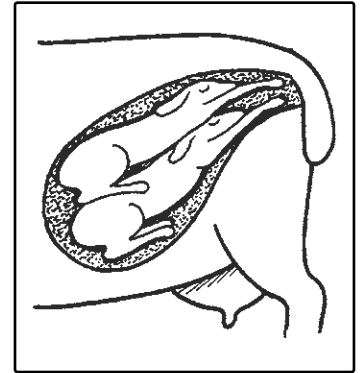
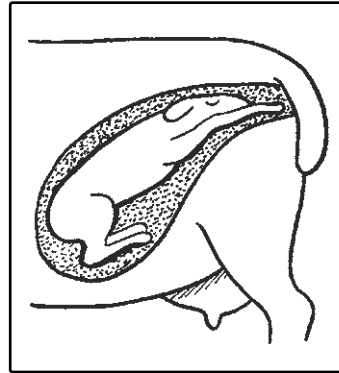
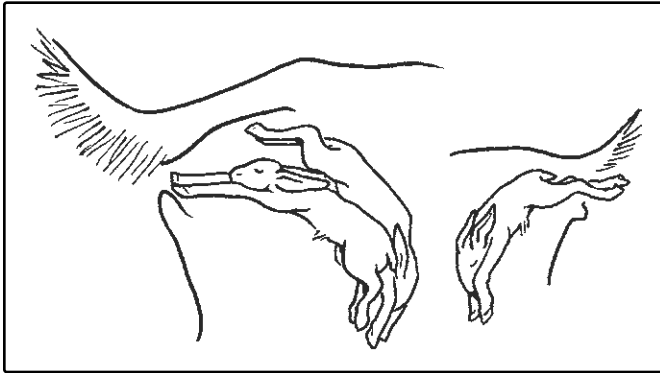

Colostrum (the first milk) contains vital antibodies and nutrients. Be sure all kids and lambs receive colostrum shortly after birth. Contact your vet or ATTRA for more information on newborn care.

Disbudding dairy goat kids (to be done before 10 days of age):

1. heat iron
2. restrain kid
3. hold hot iron over horn bud as shown for 10-20 seconds.
4. check for copper rings on both horn buds.

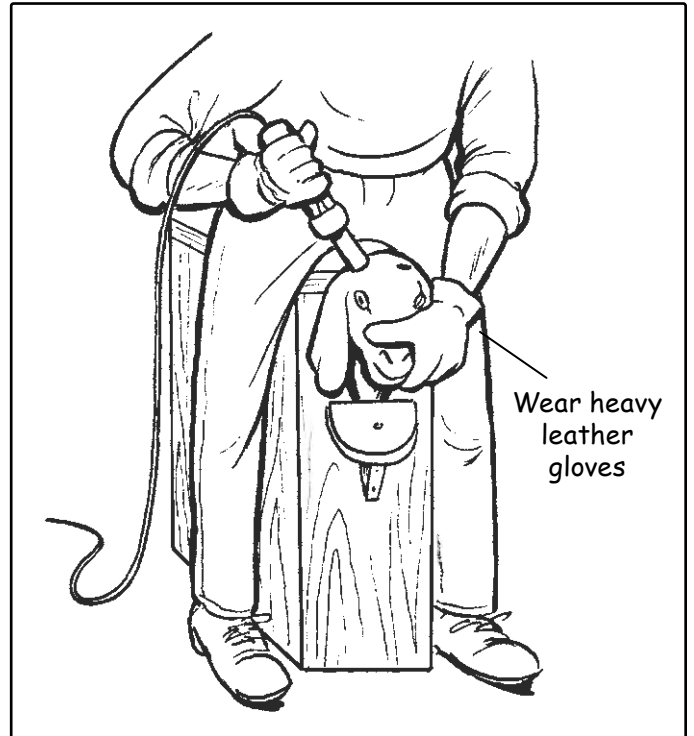

Copper-colored rings



Elastrator tool for docking tails and castrating lambs and kids.

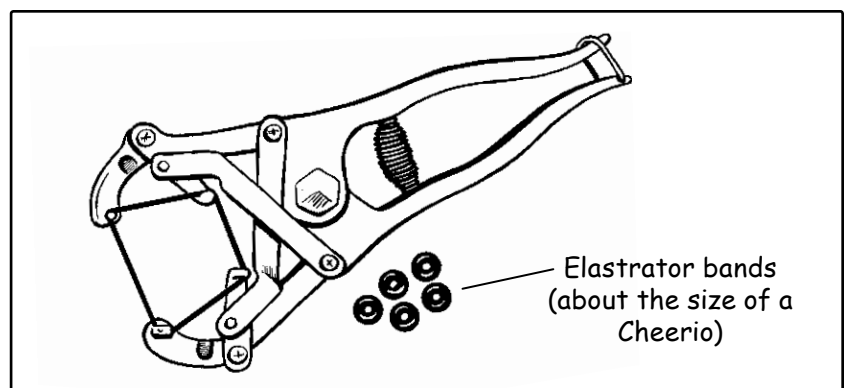

Castrating with elastrator (to be done before 10 days of age).

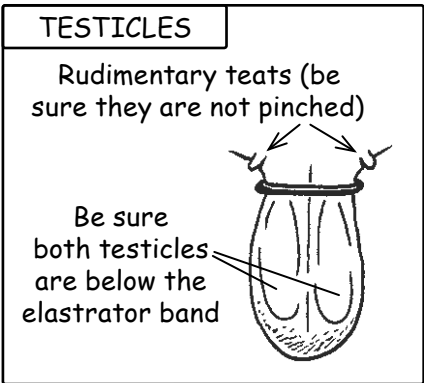
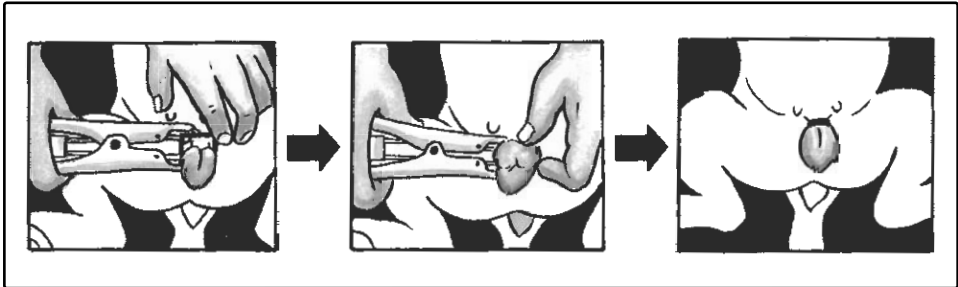

Docking a lamb's tail with elastrator.

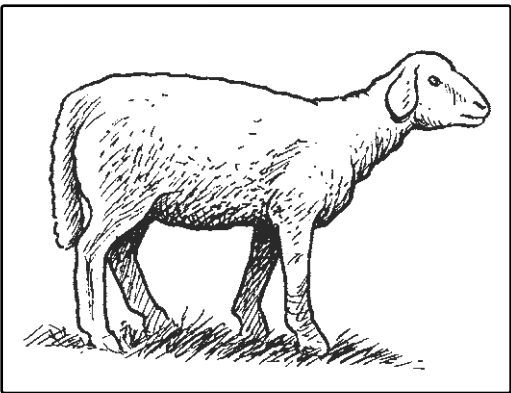
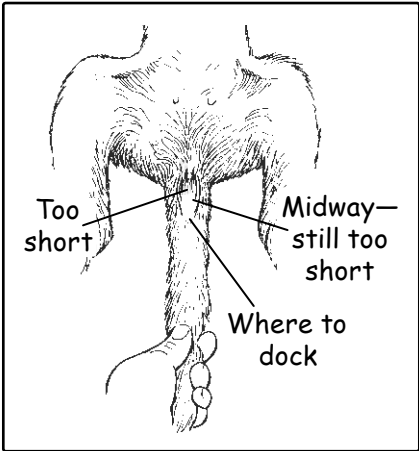
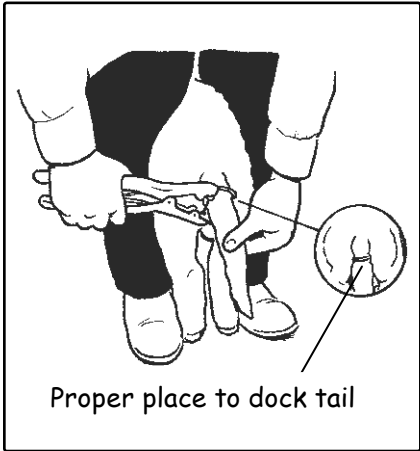

Hair sheep do not need to have their tails docked.

All animals should be permanently identified with ear tags, tattoos, or ear notching.

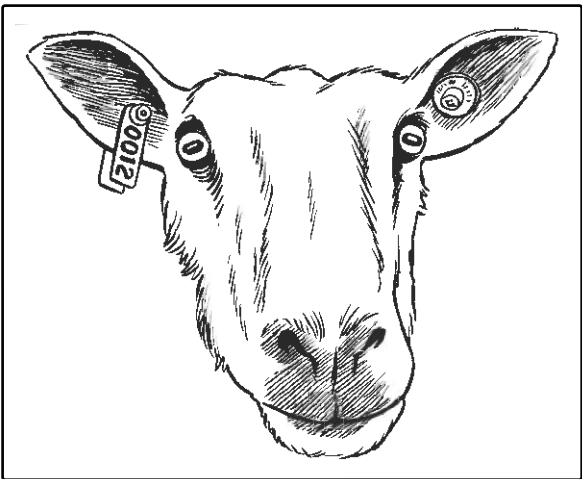
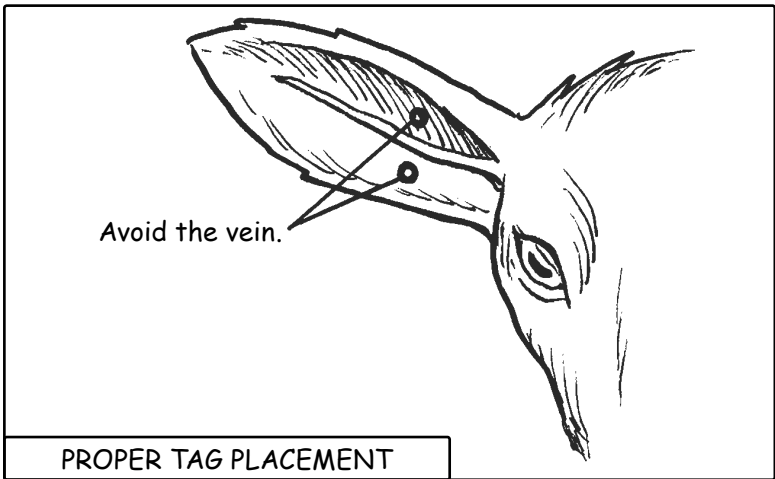

- All states require certain sheep and goats to be officially identified on change of ownership, as part of USDA's Scrapie program.
- Call 1-866-USDA-TAG for information and to request your free tags.

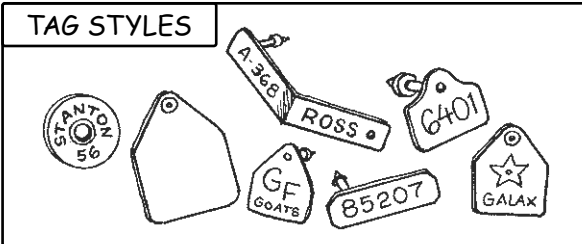

# HEALTH

- Healthy, productive animals are more profitable and enjoyable to raise. Refer to the *Selection* section for signs of healthy and sick animals.
- It is important to have a working relationship with a veterinarian. A veterinarian can help with prevention, diagnosis, and treatment of disease.



Keep records of health treatments, including day of treatment and withdrawal periods.

HEALTH				
Animal ID	Date	Condition	Treatment	Comments

- Internal parasites are one of the primary health concerns for sheep and goat producers.
- Parasite eggs are passed by the animals, and infective larvae are picked up from pasture.

## INTERNAL PARASITE LIFE CYCLE

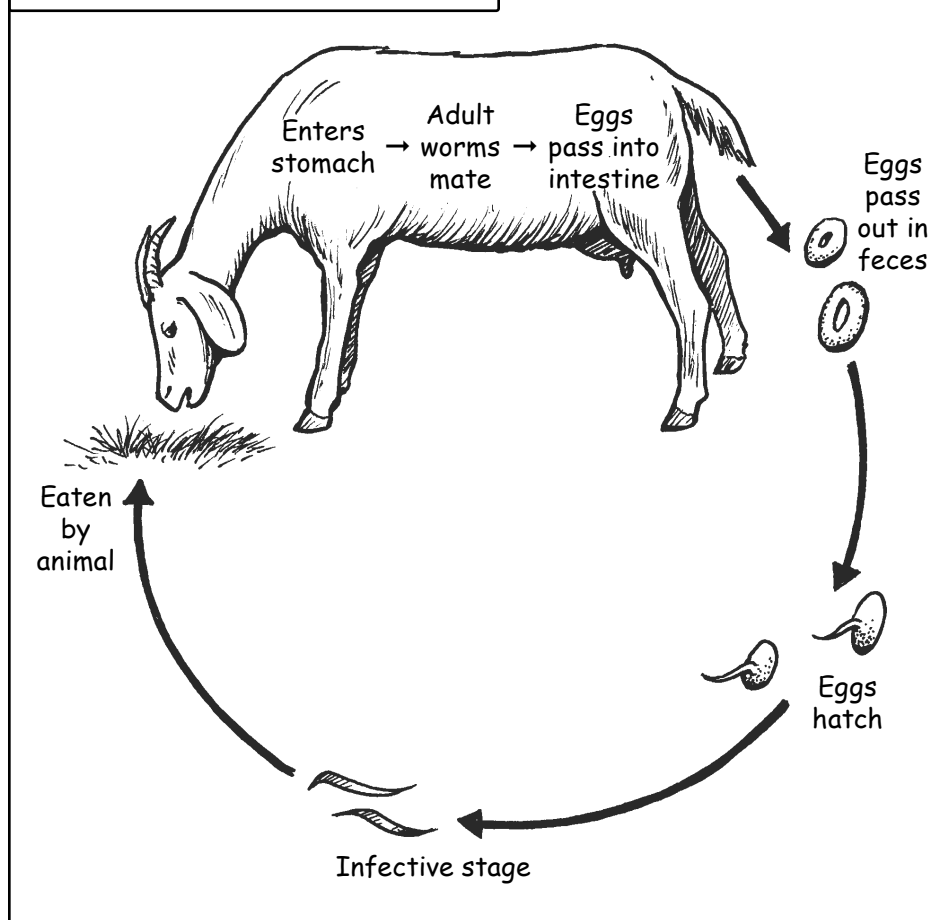

Signs of parasitism include:

- Rough hair coat
- Thin/unthrifty
- Bottle jaw
- Anemia

## BOTTLE JAW



## ROUGH HAIR COAT, THIN

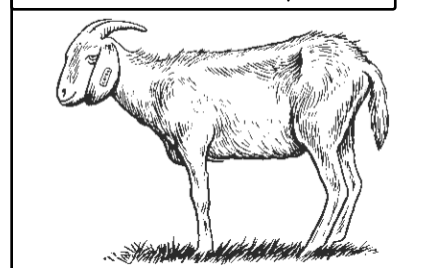

FAMACHA®

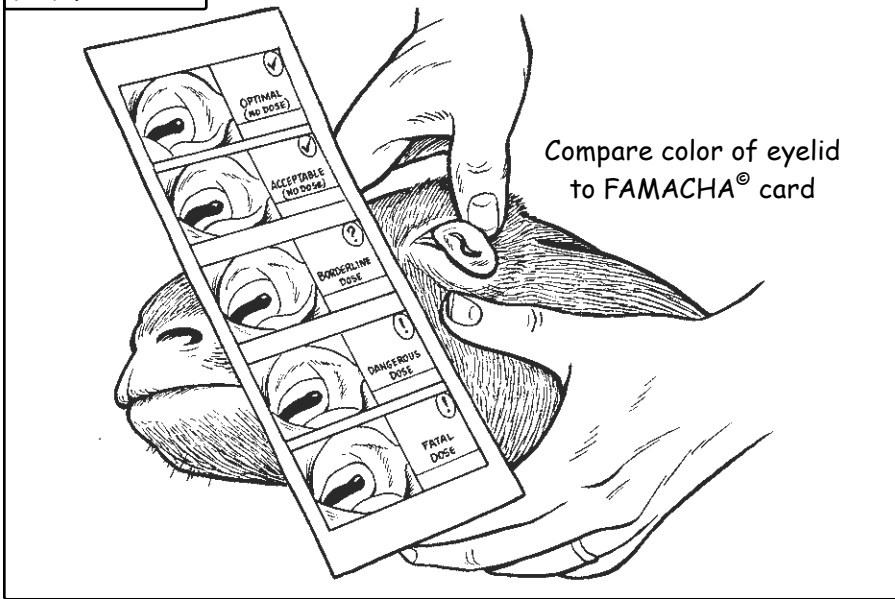

- FAMACHA® is a tool used to identify anemic animals (a sign of parasitism). By using FAMACHA® producers can identify and treat only the animals that need deworming.

- This system is useful where barberpole worms are the main parasite. Contact your veterinarian to learn more about FAMACHA®. Also see [www.scsr.org](http://www.scsr.org).

There are many vaccinations that can be given. The most common vaccinations are CD-T (clostridium/overeating disease and tetanus).

Injection methods

SUBCUTANEOUS

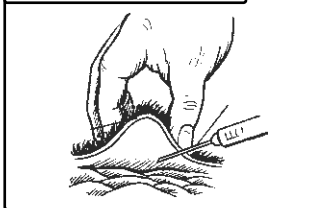

When administering drugs, pay close attention to dosages and withdrawal periods. Most drugs have a withdrawal time for meat and milk.

INJECTION SITES

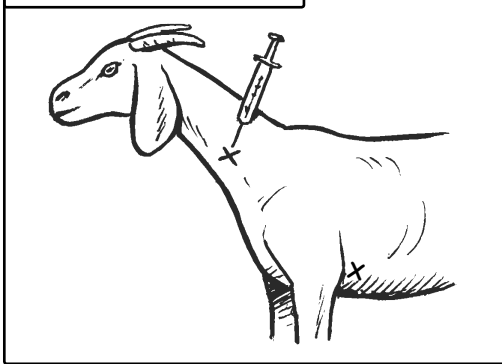

INTRAMUSCULAR

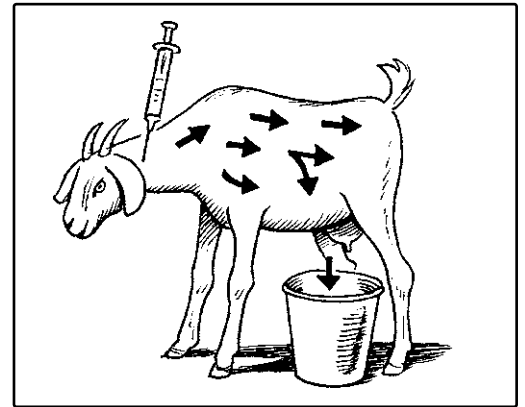

Alligator clip for security

String

Rectal Thermometer  
Inserted in rectum,  
just under tail.

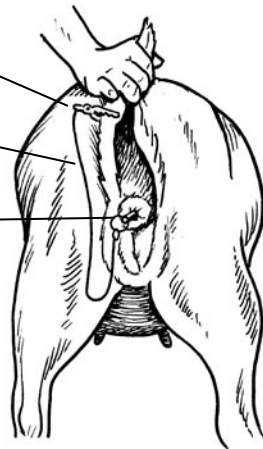

- Knowing how to take your animals' temperature is helpful in determining signs of illness.
- Normal temperature of sheep and goats is 102° F

Occasionally sheep and goats need to have their hooves trimmed. Keeping hooves trimmed helps animals to walk properly and helps prevent other hoof problems such as foot rot.

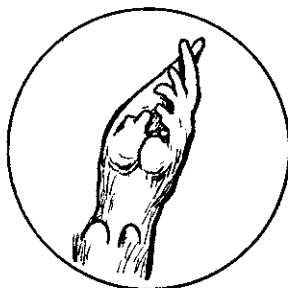
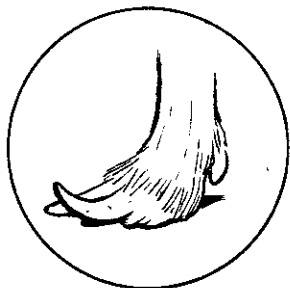

TRIMMING SHEEP HOOVES

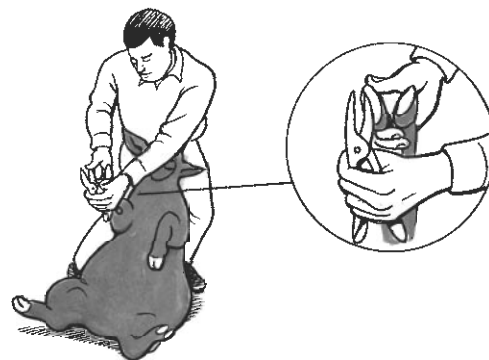

1



Dig dirt out from toes.

2



Trim, parallel to hoof hair-line, all loose excess nail.

3

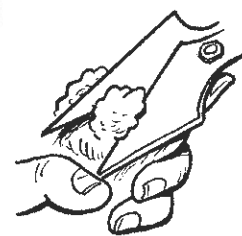

Pare heels to same level as toes.

4

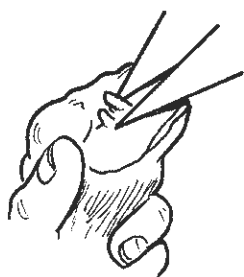

Snip away growth between toes.

5



Pare the soft heel tissue until hoof surface is smooth and flat.

6

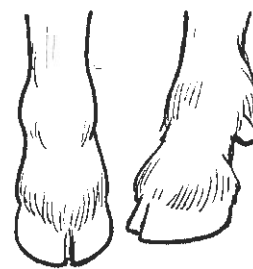

Finished hooves.

- Good health depends on you! To prevent disease, provide:
  - Good nutrition, with plenty of forage
  - Low-stress environment and handling
  - Good pasture management
  - Good sanitation
  - Protection from predators
  - Vaccinations as recommended by your veterinarian.
- Observe your animals and respond quickly to any problems.
- Animals who are poor producers or have chronic health problems should be culled.

# EQUIPMENT AND HANDLING

- Sheep and goats are easy to handle and do not require a lot of equipment.
- You should provide a shelter to protect animals from rain, snow, and cold winds.
- There are many different shelter options, from simple structures to more complex barns.

THREE-SIDED SHELTERS WITH OPEN SIDE AWAY FROM PREVAILING WINDS ARE IDEAL.

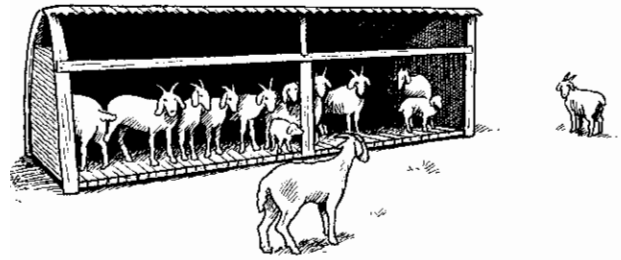

PERMANENT BARN

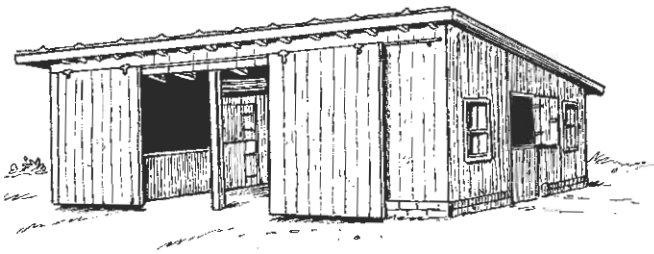

MOVEABLE SHELTER ON SKIDS

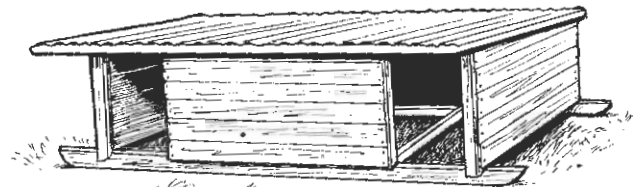

HOOPED CATTLE PANELS WITH TIGHT TARP

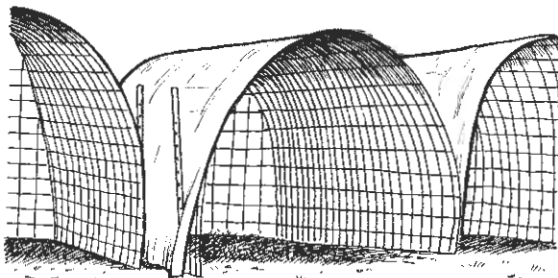

- Clean, dry, well-ventilated shelters help animals stay healthy.
- Moveable shelters help prevent manure buildup in an area.
- Shelters and working facilities can be home built for lower cost.

A catch pen, chute, and head gate are helpful when working with sheep and goats. For very small flocks, a catch pen is sufficient.

CATCH PEN AND CHUTE



HEAD GATE



A scale is very useful. Knowing animal weight helps you:

- Monitor animal growth
- Calculate dosages of medications
- Decide when to market animals
- Determine a selling price

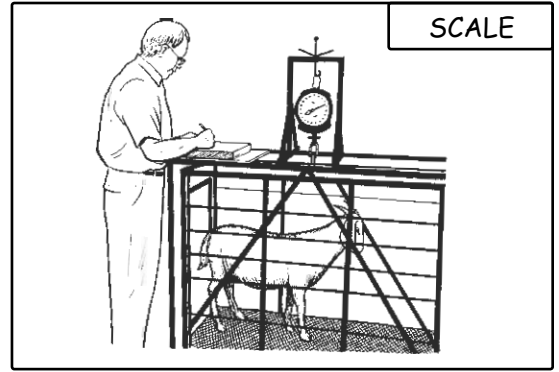

- Sheep can be restrained by setting them on their rump.
- Goats should be restrained by holding them under the jaw and the rump.
- Sheep and goats are easier to control if you keep their heads held high.

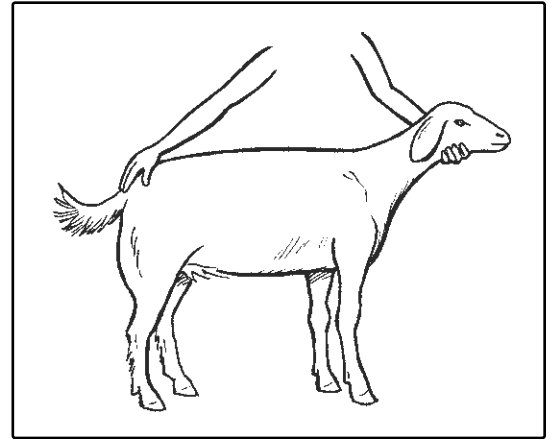

## MARKETING

- When marketing sheep and goats, it is important to determine who your customers are and what they want.
- Many religious and ethnic groups prefer lamb and goat.

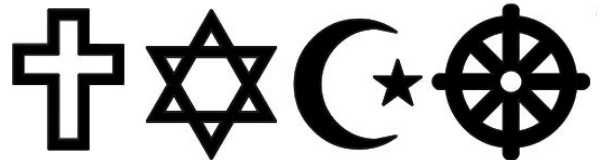

Explore local options for selling your products. Market options include:

ON-FARM SALES

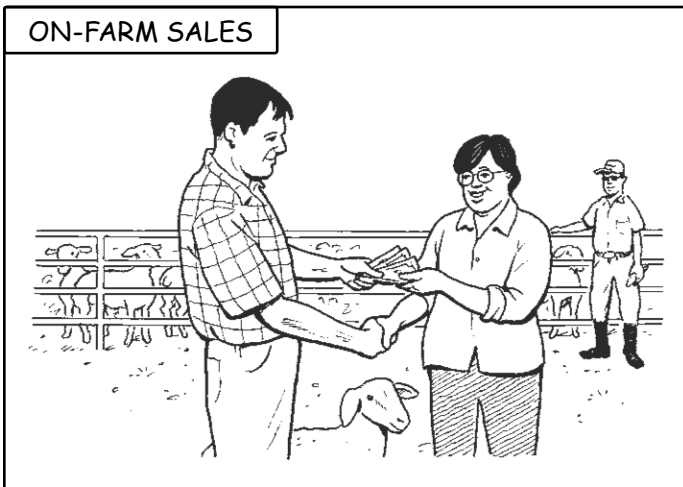

SALE BARN

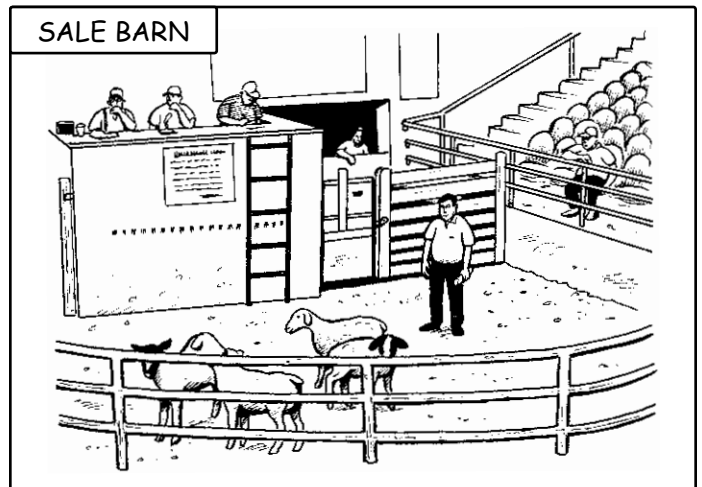



COOPERATIVE SALE

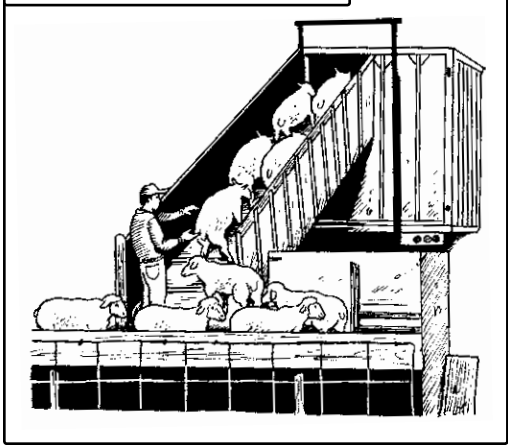

Producers pool their animals to sell a large group to a buyer.

WHOLESALE

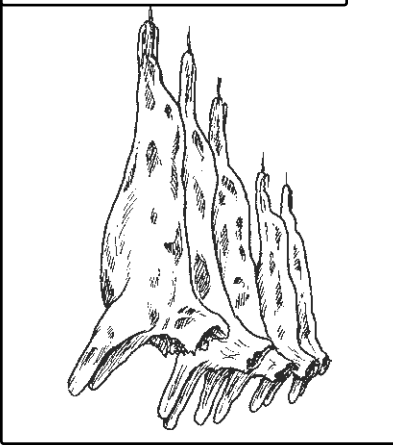

Selling carcasses to butcher shops and restaurants.

RETAIL



Selling packaged cuts.

GRADED SALE

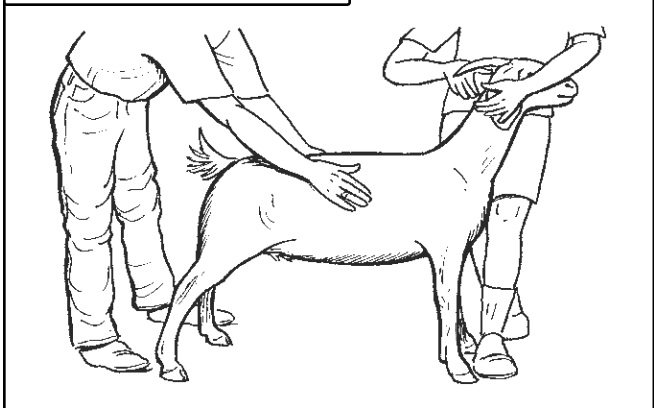

USDA grader inspects animals. Heavier muscled animals bring a premium.

Other products:

ORGANIC



You may explore organic sheep and goat production. First determine if there is a market and if organic production would be profitable. Contact ATTRA for more information.

GRAZING SERVICES



Sheep and goats can improve land by controlling brush or invasive weeds. Some landowners are willing to pay for this service.

FLEECE



Wool and mohair can be sold to individuals or to a pooled sale. Higher grade fleeces will bring a better price.

MILK

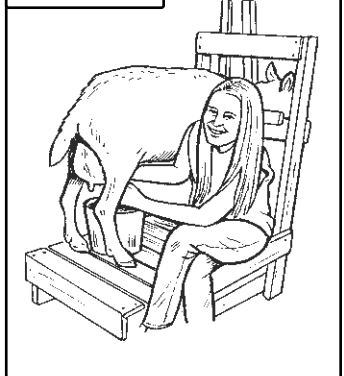

Rules for selling milk and milk products vary by state.

# CONCLUSION

Wherever you live, sheep and goats may have a place on your farm. You must first determine the goals for your farm and then explore profitability of the sheep and goat enterprise. To learn more, see the resources listed on the next page.

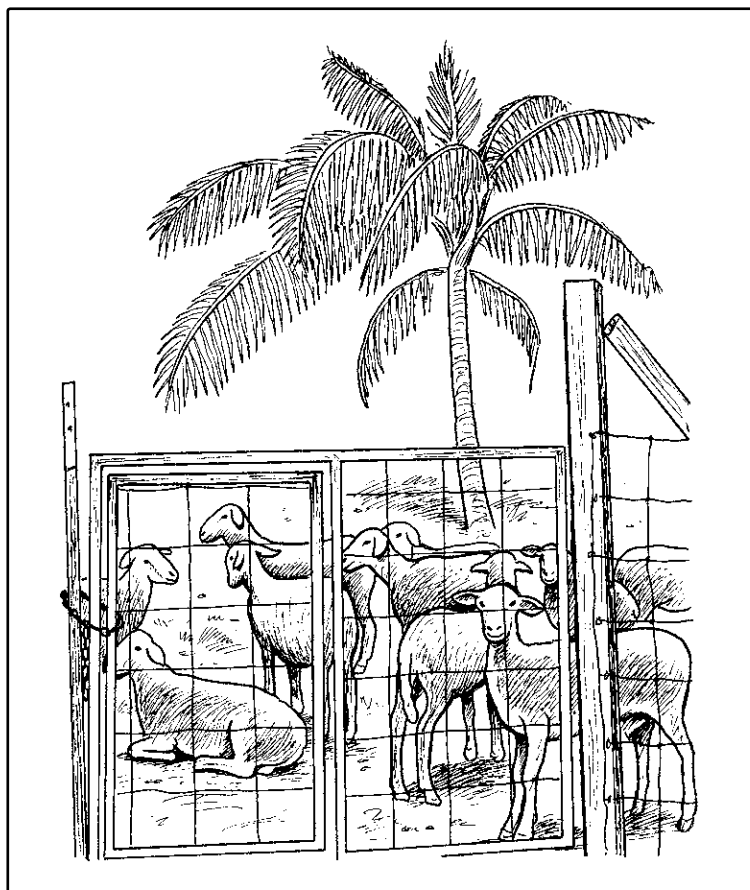
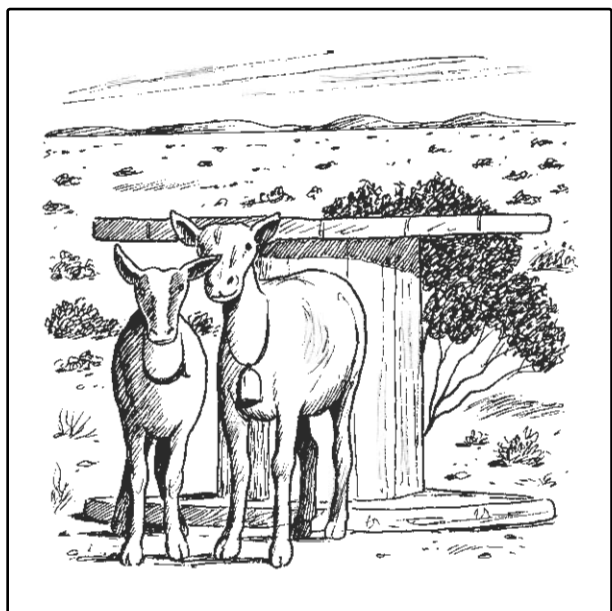
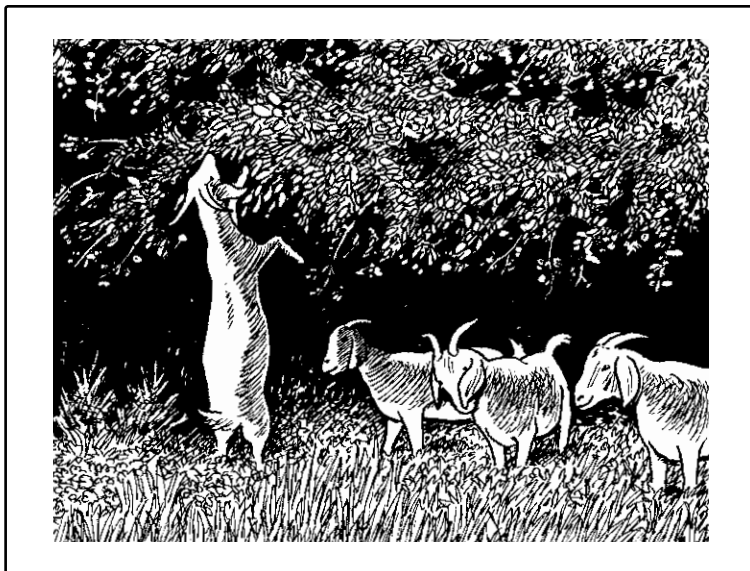
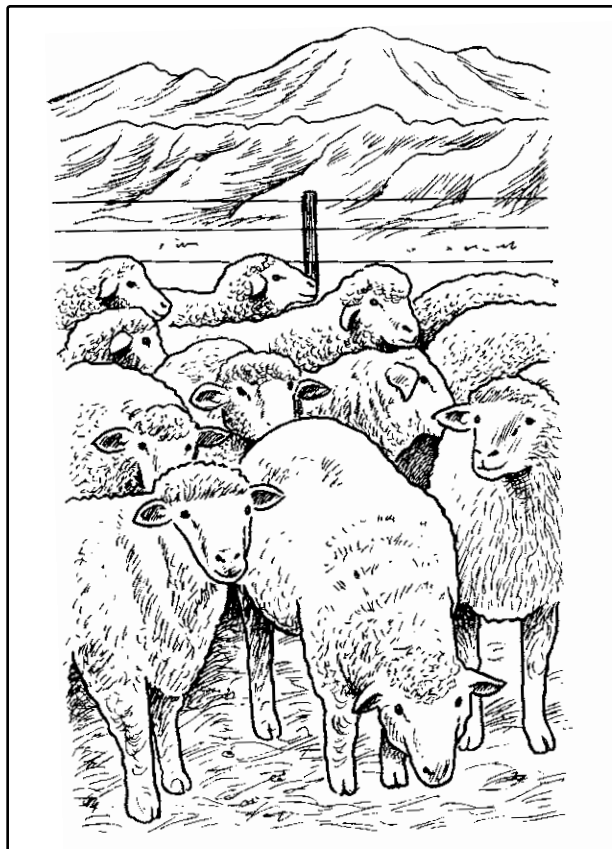

## FINDING OUT MORE: Resources for sheep and goat producers

Call **ATTRA** at 800-346-9140 or visit [www.attra.ncat.org](http://www.attra.ncat.org) for free publications about sheep and goat production, pasture management, predator control, internal parasite control, and more.

Your local **Cooperative Extension Service** will often sponsor workshops and seminars to help you learn more. Your local agent can also put you in touch with other producers, inform you of markets in the area, and assist you in learning about regulations that affect your business. If you have difficulty locating the agent, you may call ATTRA (800-346-9140) and we will find the number.

Visit your **public library** and explore the shelves where agriculture books are located. A partial list of useful titles may be found in the ATTRA publication *Small Ruminant Resource List*. You may call 800-346-9140 to ask for a free copy of the list or download it at [www.attra.ncat.org/attra-pub/small\\_ruminant\\_resources.html](http://www.attra.ncat.org/attra-pub/small_ruminant_resources.html).

You will also find a wealth of information **online**. The *Small Ruminant Resource List* includes many good websites to explore. There are many training courses and short tutorials available online as well, including:

**Maryland Small Ruminant Page**  
[www.sheepandgoat.com](http://www.sheepandgoat.com)

**Sheep 101**  
<http://www.sheep101.info/>

**Sheep 201**  
<http://www.sheep101.info/201/index.html>

**Penn State Meat Goat Course**  
<http://bedford.extension.psu.edu/agriculture/goat/Goat%20Lessons.htm>

**Langston University Master Goat Producer online course**  
<http://www.luresext.edu/goats/training/QAtoc.html>

**The Goat Dairy Library**  
<http://goatdairylibrary.org/>

A good **magazine** is a link to other producers and to continuing education on timely topics. The *Small Ruminant Resource List* includes some of the most relevant magazine titles.

Learning from **other producers** is most beneficial. If you have opportunity to visit another farm, you can observe practices that work well, and some that do not: you can ask questions and look at facilities and discuss markets. If possible, it is good to cooperate with others in your area to build a strong network of sheep and goat producers.

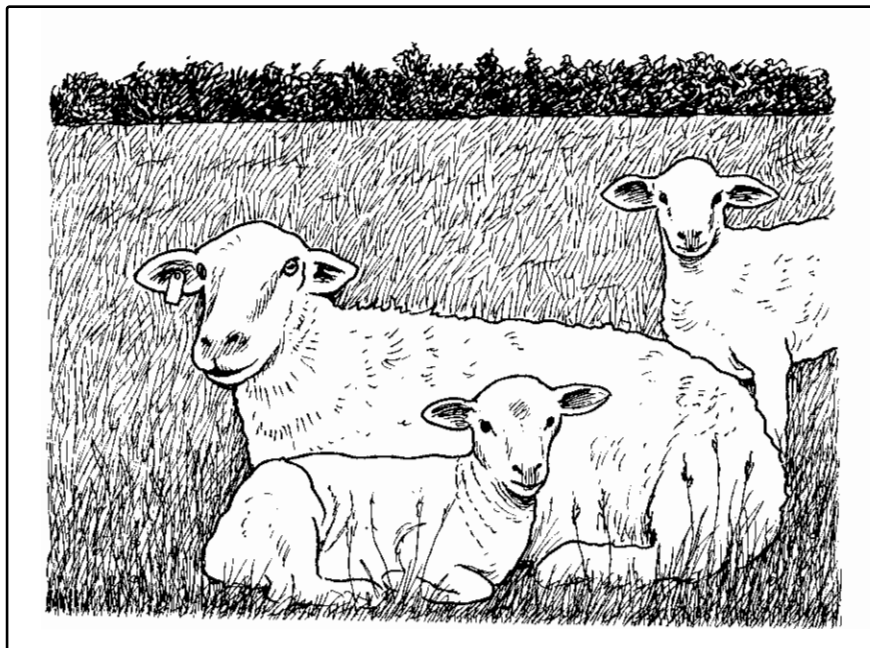

## RELATED ATTRA PUBLICATIONS

---

- Goats: Sustainable Production Overview
- Meat Goats: Sustainable Production
- Dairy Goats: Sustainable Production
- Sustainable Sheep Production
- Dairy Sheep
- Small Ruminant Sustainability Checksheet
- Small Ruminant Resource List
- Managing Internal Parasites in Sheep and Goats
- Pasture, Rangeland and Grazing Management
- Ruminant Nutrition for Graziers
- Tools for Managing Internal Parasites in Small Ruminants: Copper Wire Particles
- Tools for Managing Internal Parasites in Small Ruminants: Sericea Lespedeza
- Predator Control for Sustainable and Organic Livestock Production
- Pastures: Sustainable Management
- Multi-Species Grazing
- Rotational Grazing
- Paddock Design, Fencing, and Water Systems for Controlled Grazing
- Value-added Dairy Options
- NCAT's Organic Livestock Workbook
- The Organic Chronicles
- Pastures: Going Organic
- Organic Farm Certification and the National Organic Program

### ***Special thanks for reviewing this publication to:***

Jack Black	Dr. An Peischel
Joe Black	Dr. Charlotte Clifford Rathert, DVM
Dr. Steve Hart	Dr. Beth Walker
Gary Jones	Stuart Weiss
Bruce Lane	
Janice Neighbor	

We would also like to thank NCAT staff members Karen Van Epen, Rex Dufour, Tracy Mumma, and Lee Rinehart for their review.

An Illustrated Guide to Sheep and Goat Production  
By Linda Coffey and Margo Hale  
NCAT Agriculture Specialists  
© 2008 NCAT

Robert Armstrong, Illustrations  
Robyn Metzger, Production

This publication is available on the Web at:  
[www.attra.ncat.org/attra-pub/sheep\\_illus.html](http://www.attra.ncat.org/attra-pub/sheep_illus.html)  
or  
[www.attra.ncat.org/attra-pub/PDF/sheep\\_illus.pdf](http://www.attra.ncat.org/attra-pub/PDF/sheep_illus.pdf)

IP330  
Slot 323  
Version 101508

# GOATS: SUSTAINABLE PRODUCTION OVERVIEW

## LIVESTOCK PRODUCTION GUIDE

***Abstract:** Goats: Sustainable Production Overview provides fundamental information relevant to all goats, especially about feeding, reproduction, and health. An extensive resource list is included. Read ATTRA's Dairy Goats: Sustainable Production and Sustainable Goat Production: Meat Goats for more complete information, including sections on marketing and profitability.*

By Linda Coffey, Margo Hale, and Ann Wells  
NCAT Agriculture Specialists  
August 2004  
© NCAT 2004



## Table of Contents

Selection.....	2
Feeding Ruminants.....	3
Raising Goats on Pasture.....	3
Marketing.....	15
Profitability .....	16
Resources.....	16
References.....	23

The goat was one of the first animals to be domesticated by humans, about 9,000 years ago. Today, there are some 200 different breeds of goats that produce a variety of products, including milk, meat, and fiber (mohair and cashmere). Worldwide, goat meat production is higher than meat production from cattle or hogs. (Holcomb, 1994)

Raising goats can be a valuable part of a sustainable farm. Integrating livestock into a farm system can increase its economic and environmental health and diversity, thereby making important contributions to the farm's sustainability. Goats often fit well into the biological and economic niches on a farm that otherwise go untapped. Goats can be incorporated into existing grazing operations with sheep and cattle, and they can also be used to control weeds and brush to help make use of a pasture's diversity.

Erosion on land used for row crops declines when the land is converted to pasture. Rotating row crops and pasture every year or two offers both fertility and pest control advantages. Goats eat the forages, the goats' manure replaces some purchased fertilizers, and the life cycles of various crop and animal pests are interrupted. Like other ruminant animals, goats convert plant material that is unsuitable for human consumption into high-quality animal products.

**Related ATTRA publications:**  
Sustainable Goat Production: Meat Goats  
Dairy Goats: Sustainable Production

# Selection

When selecting animals for your herd you must first decide what traits are important to you and what the animals will be used for. Find a producer with the type of animals that you are interested in. You may locate producers by contacting your local Extension agent, searching classified ads in goat publications, contacting goat clubs or associations, or by attending meetings or seminars for goat producers. Once you have found a producer with goats for sale, visit the farm to observe the herd and the management. The animals will adapt more easily to your farm if their prior management and environment are similar to yours.

To develop a productive herd it is imperative that you select healthy animals. Never build your herd with animals from the sale barn. These are often animals that have been culled by another producer. There is a reason they were culled, and you do not want to bring those problems to your herd.

Listed below are some of the signs of a healthy animal.

- Shiny coat
- Lively manner
- Easy movement (no limping, no swollen joints or misshapen udders)

- No abscesses
- Proper conditioning (not fat or excessively thin)
- Firm, pelleted manure
- Well-shaped udder and teats

Also, ask the producer questions such as what diseases have been problems in the herd, what is the vaccination/worming protocol, and what criteria are used for selection and culling. You should also ask your veterinarian about diseases that are possible problems in your area. When selecting your animals, also observe their conformation. Drawings 1 and 2 illustrate some of the characteristics of good and bad conformation in goats. Dr. Steve Hart of Langston University points out that for most operations, conformation is a relatively minor concern; health and soundness are much more important. He advises checking to see that the bite is correct (not over-shot or under-shot) and that the legs and feet are sound.

For more details on selection of goats, see the pertinent ATTRA publication for the goats you intend to raise (*Dairy Goat, Meat Goat*).

To run an efficient operation, it is necessary to identify animals (by tattoos or ear tags) and keep records. Breeding, reproduction, and production records are helpful in identifying which animals are most productive and which should be culled.

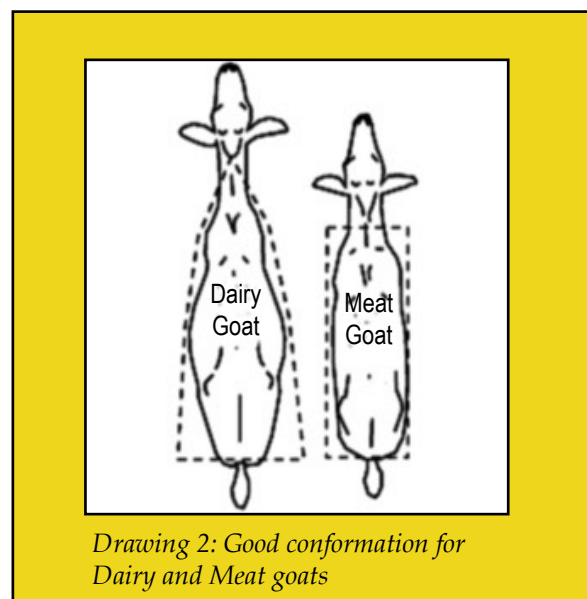
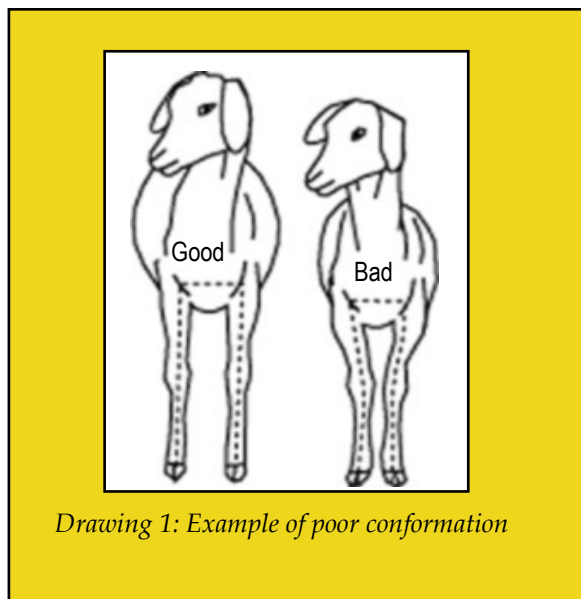

*Drawings from Mississippi State University Extension Service 4-H Club Goat Guide.  
(<http://msucares.com/pubs/publications/p2264.htm>)*

# Feeding Ruminants

---

Goats are ruminants; that is, they have a four-compartment stomach designed to digest large quantities of forages. Ruminants eat quickly and swallow their food at first without much chewing. Later, they regurgitate their food and thoroughly chew it and swallow. This regurgitated food is called the cud, and healthy ruminants will spend as much time chewing their cud as they do grazing or eating hay. This is thought to be a predator avoidance adaptation, as the ruminant can find a sheltered place to peacefully chew its cud and be less vulnerable to predator attack than while grazing.

The ruminants get their name from the *rumen*, which is the largest compartment of the stomach and serves as a fermentation vat. The health and productivity of the goat (as with all ruminants) depends on the rumen function; microorganisms in the rumen digest fiber and carbohydrates and protein to supply the animal with nutrients. Without those microorganisms, the goat will become very sick and may die. Therefore, it is of paramount importance that the animal be fed appropriately so that the ruminal organisms stay healthy.

These rumen organisms require fiber, nitrogen (protein), and energy (carbohydrates). Roughages (forages—pasture, hay, browse) have higher fiber content than grains. More mature forages contain more fiber and are less digestible. Energy is provided by good-quality (digestible) roughages and by concentrates (grains).

The rumen microorganisms have preferred pH ranges; those that digest fiber best thrive in a range of 6.0 to 6.8. Rumination (chewing the cud—required to digest roughage) increases the amount of saliva, which buffers the rumen fluid and maintains the favorable pH. However, grain (especially finely ground grains) decreases rumination; which means less saliva reaches the rumen, and the pH decreases. Also, in the process of digesting grain, lactic acid is produced, which can further lower the pH. When a goat eats too much grain, the rumen pH can drop below 5.5, killing the normal rumen microorganisms and resulting in a very sick animal.

The rumen microorganisms are “healthiest” when goats are eating good-quality forages, such as vegetative pasture. However, it is difficult (if not impossible) to provide good-quality forages

year-round. Therefore, supplementation with concentrates may sometimes be necessary (see *Supplemental Feeding* section of this publication).

## Raising Goats on Pasture

---

Contrary to the popular image of goats thriving on tin cans, goats actually require a more nutritious diet than do other ruminants. Their shorter digestive system does not retain food for as long, and thus does not digest nutrients fully. This quicker digestion allows them to eat larger quantities of food to make up for their reduced absorption of nutrients, but it is goats’ unique grazing behavior that really enables them to thrive on pasture. With their small mouths and flexible lips, grazing goats are able to select the highly nutritious parts of plants and leave parts that are less nutritious. This gives them an advantage over cattle that graze by taking large mouthfuls; within that large mouthful there might be a great quantity of poor-quality forage, including some that is dead or overly mature.

Each goat is able to consume up to 3 to 5% of its body weight in dry matter daily (perhaps more if the forage is highly digestible). To consume that amount, however, goats must be pastured in an area with a large quantity of available vegetative forage. Goats will eat less when they are moved to poor pastures. Listed below are some of the factors that influence intake.

- Age, size, stage, and level of production of the animal
- Animal’s health
- Animal’s forage preferences (which are influenced by its mother and peers)
- Weather
- Palatability of food
- Digestibility (fiber content)
- Maturity of forage

Goats prefer browsing (eating woody plants) but will also graze on grasses and weeds. Goats are known to stand on their hind legs to reach leaves and brush. Since goats, cattle, and sheep prefer different forages, in many pasture situations these species do not compete for the same food. Therefore, they can be managed quite suc-



PHOTO BY CHARLIE RAHM © NRCS 2004

cessfully in a multispecies grazing system, allowing the land to be used more fully and generate more income. Land grazed by both goats and cattle returns 25% more than land grazed only by cattle. (Holcomb, 1994)

Adding goats to a grazing system will have weed control benefits. Goats will eat such weeds as leafy spurge, multiflora rose, and brambles, decreasing the need for commercial herbicides or mowing. Meat and fiber goats are particularly useful for brush control. For a report on work done in North Carolina using goats alone or with cattle, see "Use of Goats as Biological Agents for the Control of Unwanted Vegetation" (Luginbuhl et al., 1996a), at <[www.cals.ncsu.edu/an\\_sci/extension/animal/meatgoat/MGVeget.htm](http://www.cals.ncsu.edu/an_sci/extension/animal/meatgoat/MGVeget.htm)>. For a concise article that explains some of the management issues pertaining to grazing goats to eradicate multiflora rose, see the Ohio State University Bulletin 857, "Multiflora Rose Control," at <<http://ohioline.osu.edu/b857/pdf/b857.pdf>>. One use of grazing goats in the West is to control leafy spurge; see "Controlling Leafy Spurge using Goats and Sheep" (Sedivic et al., 1995), at <[www.ag.ndsu.edu/pubs/plantsci/hay/r1093w.htm](http://www.ag.ndsu.edu/pubs/plantsci/hay/r1093w.htm)>.

htm#goats>.

When grazing goats, farmers must protect their pastures from being overgrazed. There are several reasons for this. Overgrazing forages

- eventually kills the plants
- reduces the longevity of the stand and exposes more soil to erosion
- means the animals don't get enough food
- increases the chance of goats ingesting internal parasite larvae
- creates bare spots, creating opportunities for undesirable weeds and erosion

The end result of overgrazing is reduced performance of both the pasture and the animals, and health problems for the animals. To prevent overgrazing, farmers should be careful to understock rather than overstock land and always remove animals from a pasture when the pasture is grazed down to about 3 to 4 inches. Browse must be managed so that it is maintained and



not killed. If you want long-term production of browse, you must rotate the animals and not allow the area to become over-browsed.

Fencing is the most critical factor in raising goats on pasture. There is nothing more frustrating than having to constantly chase goats back into the pasture. Fencing will also be the greatest expense, other than the initial cost of the animals. The best permanent fencing is 4-foot woven wire with barbed wire along the top. Some graziers are also successfully using four or five strands of high-tensile electric wire. Goats may have to be trained to electric fences by placing them in a small paddock to "test" the wire. Once they have been trained to an electric fence, goats can usually be controlled with two strands of wire in a cross-fence. Electric netting is also an option for temporary or permanent fencing in management intensive grazing systems; however, several goat producers have lost animals that tangled their horns in the netting. It is very important to keep electric fences charged at 4,500 volts or more. Regular checking and testing are necessary, and any problems must be fixed promptly, or goats will escape.

Goats also need shelter. They can tolerate cold weather, but goats will get chilled by wet, cold conditions. The necessary shelter or shelters depend on the producer's operation. A dairy operation will usually have extensive barn and pen set-ups, while a large meat goat operation may use only trees in the pasture as shelter. Buildings used for shelter may be minimal, but they should be well-ventilated and clean. Barns and sheds are not the only options for shelter. There are portable shelters, moveable shades, and even old hog huts that can be used as shelters for your animals.

Predators are a problem in most areas where goats are produced. For information on how to control predators, see the ATTRA publication *Predator Control for Sustainable & Organic Livestock Production*.

## Controlled Grazing

In the U.S., continuous grazing is a common practice, characterized by giving the animals unrestricted access to the pasture throughout the season. This works well for goats. However, feeding goats in a sustainable and economical way is better accomplished by a controlled, rotational

grazing system, also known as management intensive grazing (MIG, commonly pronounced "mig"). The MIG systems have been used more extensively with cattle than with sheep or goats. Much work has been done recently with goats using MIG, although it is not yet widely published. However, for a review of studies of goats and grazing, see "Meat Goats in Land and Forage Management" (Luginbuhl, 1996b), at [www.cals.ncsu.edu/an\\_sci/extension/animal/meat-goat/MGLand.htm](http://www.cals.ncsu.edu/an_sci/extension/animal/meat-goat/MGLand.htm).

The basic principle of MIG is to allow animals to graze for a limited time and then move them to another pasture or paddock (a subdivision of a pasture). The pasture forage plants can then grow back without using up all of their root reserves. Even brush will need a recovery time if it is being used as forage for goats. In fact, woody plants may need to be rested a full year to remain a forage source in the pasture. Without this rest period, the goats can kill the brush through continuous browsing. Under MIG, legumes and native grasses may reappear in the pasture, and producers often report that the pasture plant community becomes more diverse. Management intensive grazing can be used to improve the pasture, extend the grazing season, and enable the producer to provide a higher quality forage at a lower cost with fewer purchased inputs. MIG can also be useful in reducing internal parasite problems, *if* farmers are careful to move the goats to a new pasture before the forage plants are grazed too short (too short is less than about 4 inches – see **Health** section for more about parasites). While the benefits of MIG are substantial, it does require increased management skill and adequate fencing and watering facilities. For more information on pastures and grazing, see the list of ATTRA publications in the **Resources** section.

The goal of MIG is to have paddocks small enough that they can be grazed in a few days (usually one to ten). The time will depend on the number of goats and the quality and quantity of the forage. How long a herd remains in a paddock will vary, depending on the intensity of management, time of year, and stage of growth of the forage. When beginning with MIG, make big paddocks and use long rotations. As producers become more familiar with the pasture plants and the goats' grazing habits, they usually subdivide paddocks with electric fence. Temporary subdivisions allow the grazier to define the pad-

docks in response to different growing conditions and the goats' changing feed requirements.

Fresh, clean water must always be available. In a MIG system, the animals either have access to a central water source available from every subdivision, or water is provided separately to each of the pasture's subdivisions. This can be a challenge, and it is another capital expense. Feed intake will decrease more for goats than for cattle or sheep if clean water is not readily available.

Along with water, minerals need to be available to your animals at all times. It is best to feed calcium, phosphorous, and trace minerals in a salt mixture to ensure that the animals actually eat them. Test your forages to determine their mineral content and adjust mineral supplementation as needed. Your local Extension agent can have your forage analyzed. Mineral content of forage is quite variable across the country, and the type, stage, and level of production of the animals influence mineral requirements; therefore, no one mineral supplement formula is right for all locations or situations. For instance, a heavy-producing dairy goat will need more calcium and phosphorus than a dry (non-lactating) meat goat. Consult a livestock nutritionist for help in identifying a good mineral mix for your operation.

It is very important that you consistently offer this mix (preferably in a loose form), monitor its consumption, and ensure that all the goats are in fact eating adequate amounts of the mineral

supplements.

In some operations – particularly dairies – goats are raised in confinement, and all their feed is brought to them. However, allowing goats to graze can lower costs in the following ways.

- By reducing purchased grain costs
- By eliminating forage harvesting costs
- By eliminating manure removal costs
- By lowering fertilizer costs as manure nutrients are returned to the soil

Goats have the ability to select the more nutritious parts of a plant. Therefore, they typically will consume a higher quality diet if they have the opportunity to be selective. With the exception of lactating dairy goats, goats grazing a high-quality pasture can usually meet their protein requirements without supplemental feeding. In some cases an energy supplement (grain) may be necessary. More information on pasturing goats is provided in ATTRA's *Dairy Goats: Sustainable Production* and *Sustainable Goat Production: Meat Goats*.

## Supplemental Feeding

While good quality forages are usually adequate, goats may sometimes need supplemental feeding, especially during the winter. Goats need a proper balance of energy in the form of

roughage or grain, as well as protein, vitamins, minerals, and clean water. Protein and energy requirements vary, depending on the type of goat and its stage of production (see Table 1).

There is a rule of thumb for all goats: browse and pasture in the summer, hay and grain in the winter, trace-mineralized salt at all times. (The mineral mixture should be fortified with selenium if you live

TABLE 1. DIETARY PROTEIN AND ENERGY REQUIREMENTS OF GOATS*.			
CLASS OF GOAT	AVG. FEED INTAKE / DAY, LB <sup>1</sup>	% CRUDE PROTEIN	%TDN <sup>2</sup>
GROWING DOELING, 45 LB <sup>A</sup>	2.4	8.8	56
GROWING MALE KID, 66LB <sup>B</sup>	2.9	9.0	57
YEARLING DOE, 90 LB <sup>C</sup>	4.6	10.0	56
3 YR. OLD DOE, 110 LB <sup>D</sup>	5.0	11.7	69
MATURE BUCK, 220 LB <sup>E</sup>	5.3	9.0	55
DAIRY DOE, 150 LB <sup>F</sup>	7.5	11.6	71
*APPROXIMATIONS; BASED ON DRY MATTER IN THE FEEDS EATEN			
<sup>1</sup> CALCULATED ON BASIS OF THE DRY MATTER IN THE FEEDS EATEN			
<sup>2</sup> TDN = TOTAL DIGESTIBLE NUTRIENTS			
<sup>A</sup> GROWING AT THE RATE OF .25 LB/DAY			
<sup>B</sup> GROWING AT THE RATE OF .33 LB/DAY			
<sup>C</sup> YEARLING FEMALE, LAST TRIMESTER OF PREGNANCY AND GROWING			
<sup>D</sup> MILKING 2 QT/DAY - ENOUGH FOR TWINS			
<sup>E</sup> NOT GAINING WEIGHT, MODERATE ACTIVITY			
<sup>F</sup> NUBIAN, MILKING 1 GALLON/DAY OF 4.0% BUTTERFAT			

(PINKERTON AND PINKERTON, 2000)

**TABLE 2: SUPPLYING PROTEIN NEEDS FOR LACTATING GOATS**

% PROTEIN IN ROUGHAGE, DRY MATTER BASIS	% PROTEIN NEEDED IN CONCENTRATE
15% AND OVER EXCELLENT LEGUME HAY OR EXCELLENT PASTURE HIGH PRODUCTION (OVER 4 QUARTS/DAY) LOW PRODUCTION	14 12
12 TO 15% LEGUME-GRASS MIXED HAY OR GOOD PASTURE HIGH PRODUCTION LOW PRODUCTION	16 14
10 TO 12% GOOD GRASS HAY OR FAIR PASTURE HIGH PRODUCTION LOW PRODUCTION	18 16
BELOW 10% FAIR QUALITY GRASS HAY OR POOR PASTURE HIGH PRODUCTION LOW PRODUCTION	20 18

(PINKERTON, 1993)

in an area of the country with selenium-poor soil. Check with your Extension agent or veterinarian.) When breeding begins in the fall, producer Sue Drummond feeds her angora goats not only hay, grain, and salt but also vitamins (A, D, and E) and di-calcium phosphate. (Drummond, 1995) Kelp, a seaweed high in minerals, is sometimes used as a supplement, though it is expensive. Alternative feeds such as roots and tubers (sugar beets, mangels, sweet potatoes, turnips) may be fed for the energy content of the roots or the nutritious green tops. Various milling by-products are commonly fed to goats as well.

Grain is the concentrate most often fed to goats; cereal grains such as oats, corn, barley, and wheat are high in energy (carbohydrate/fat). Less commonplace grains such as amaranth and buckwheat are also sometimes used. Soybean meal and cottonseed meal are high-protein supplements. The choice of concentrate is determined by the composition of the forage. High-quality forages usually have adequate or even excess protein; animals eating these will need a higher-energy concentrate to utilize the protein present in the forages. Lower-quality pastures or hays will require feeding a higher-protein supplement to meet the goats' protein requirement.

Dairy goats need both high-quality forage and supplemental grain to reach their full potential, especially during peak lactation or growth. More information on supplemental feeding of dairy goats is available in ATTRA's *Dairy Goats*:

*Sustainable Production.* Fiber goats, on the other hand, may not do well with supplemental grain, because feeding too much protein to angora goats can make mohair fiber coarser and reduce its value, and feeding beyond maintenance requirements will not improve the fiber production of cashmere goats.

Goats can be picky eaters, and they may not immediately accept new feeds. Any feed changes should be made gradually to avoid upsetting the rumen microflora. Feeding very high levels of grain can also upset the rumen. Grain should never be more than 50% of the total diet, except for heavily-producing dairy goats. Adult meat goats should be fed a maximum of 1% of bodyweight in supplemental grain, with lactating does reaching a maximum of 1.5%. Feeding an animal a large amount of concentrate (grain) causes acidosis: the rumen pH will drop and rumen motility will decrease. Usually the animal will go off feed, have diarrhea, and show signs of depression for a couple of days. In severe cases, acidosis can cause death. If you know an animal has consumed too much grain, you can treat it with an antacid (sodium bicarbonate). Call your veterinarian for help, and offer only forage and water until the animal recovers.

Enterotoxemia can also occur if there is a sudden change in diet that stimulates certain rumen microbes to overpopulate and produce toxins that cause symptoms similar to acidosis. Enterotoxemia usually results in death. To prevent this

disease, all animals should be vaccinated for enterotoxemia (see **Health** section) and their access to grain or lush pasture should be controlled (increase access cautiously).

There are programs available to help goat producers determine rations for their herd. Langston University has developed a calculator (available on-line) that will be helpful in

#### Score 1 Very poor body condition

- Deep cavity under tail and around tail head. Skin drawn tight over pelvis with no muscle tissue detectable in between.
- No fatty tissue felt at loin. Pins, hooks, and short ribs can be seen; edges feel sharp.

#### Score 2 Poor body condition

- Cavity around tail head is evident, but less prominent. No fatty tissue felt between skin and pelvis, but skin is supple.
- Ends of short ribs are sharp to the touch, but individual ribs can no longer be seen. While bones are less prominent, they are still angular and can be easily distinguished by touch.

#### Score 3 Good body condition

- Slight cavity lined with fatty tissue apparent at tail head. Area between pins has smoothed out.
- Ends of short ribs can be felt with moderate pressure. Slight depression visible in loin area. Hooks and pins can be felt but have some covering of flesh. Hook, pin, and back bones appear smooth.

#### Score 4 Fatty body condition

- Depression between pins and tail head filling in. Patches of fat apparent under the skin. Pelvis felt only with firm pressure.
- Short ribs cannot be felt even with firm pressure. No depression visible in loin between backbone and hip bones. Back and area between hooks and pins appear flat.

#### Score 5 Grossly fatty body condition

- Tail head buried in fatty tissue. Area between pins and tailbone rounded, skin distended. No part of pelvis felt, even with firm pressure.

(Fredricks, 1993)

balancing rations for any class of goat. See **Contacts** section for Langston University's Web site. The Ohio Dairy Goat Ration program is available by contacting a local county office of Ohio State University Extension or

Ms. Cheryl Hall  
Department of Animal Sciences  
2027 Coffey Road  
Columbus, Ohio 43210  
614-688-3143

Some county Extension offices may have access to software that is helpful, or your agent may refer you to a ruminant nutritionist.

## Body Condition Scoring

Your goal in feeding your animals is to meet their nutritional requirements (economically) and to keep them in a productive condition. One way to monitor the animals' condition is to assign body condition scores (BCS). Body condition scoring evaluates the body fat reserves of your goats and is an easy method to evaluate the effectiveness of your feeding program. Scores range from one to five and are determined by looking at the tail-head and loin areas. Use the following guidelines to determine each goat's score.

A good source for meat goat body condition scoring can be viewed at <<http://bedford.extension.psu.edu/agriculture/goat/Body%20Condition%20Scoring.htm>>.

When scoring your herd, take into consideration the herd average; every herd has individuals that are too fat or too thin. If the herd average is under or over optimal condition, usually a score of three, you need to change your feeding regimen. Body condition will vary depending on the time of year. You should try to have your animals in good body condition before winter, so they can tolerate the cold and still have adequate reserves at kidding season. The animal's stage of production also influences body condition; for example, a doe in early lactation will almost always lose condition.

## Reproduction

Female goats (does) reach puberty at seven to ten months of age, depending on the breed and nutrition, and should be at 60 to 75% of their

adult weight at breeding to prevent difficult kidding. Does will have higher lifetime production and be more profitable if they are bred to kid as yearlings. Does should kid every year thereafter until at least the age of seven or eight, if they remain healthy. Most goats are seasonal breeders, reacting to shorter days as a cue for breeding. The presence of a buck (uncastrated male goat) stimulates the reproductive cycle (estrous) and the behaviors of the does that indicate that they are in the fertile part of their cycle (in heat). The doe's estrous cycle normally occurs from August or September until January, with October to December being the peak time for breeding. The estrous cycle is normally 18 to 22 days long. Does in heat (estrus) are at the proper stage for breeding; at this time, they will be receptive to the buck. Estrus (standing heat) lasts for 12 to 36 hours. Signs of heat include tail wagging, swollen vulva, mounting behavior, decrease in milk yield if lactating, and a general increase in activity and bleating. Kids are born about 150 days after breeding. Planning breeding so that kids are born during the height of forage production in the spring makes efficient use of the pasture. Keeping accurate breeding records will allow you to know when kids are due and help you prepare for their arrival.

Some goat milk markets demand year-round production. Breeding season may be manipulated through the use of lights and hormone therapy. However, milk production is less for a doe that kids in the fall than when she kids in the spring.

Male goats (bucks) reach puberty earlier than females and must either be separated from them by the age of four months or be castrated to prevent unwanted breedings. Buck kids can be used as herd sires at 8 to 10 months, but should not be used as heavily as mature bucks. Have your veterinarian test them for fertility and soundness before the breeding season. This test is called a breeding soundness exam and is described below.

The most important animal in the herd is the buck. He provides half of the genetics of the herd, and using a sound, high-quality buck can make significant improvements to the herd. Spend time and effort to locate a superior buck, one that has the traits you have identified as important. It is well worth the investment. A buck that has production records (has been on test or has relatives that have been on a production test) is the surest

bet. At the very least, you should observe both the herd and the parents of the buck. When selecting a buck, it is important to perform a breeding soundness exam. A general physical exam can check the buck for structural soundness and abnormalities in the sex glands and organs. The scrotal circumference (at the widest point) should be measured, since this correlates with fertility and semen production. As a general rule, dairy bucks should measure 25 to 28 cm at 100 pounds, meat bucks should measure 26 to 29 cm at 100 pounds, and larger bucks should measure at least 34 to 36 cm. (Mobini, 2003) Have a semen sample taken and evaluated. A normal concentration is 2 billion sperm per cubic centimeter of semen. Of those, 70% should be motile, moving forward. The sperms' morphology should be evaluated to determine whether they are mature and whether there are abnormalities. At least 80% of the sperm should be normal. (Mobini, 2003) Finally, the buck's libido should be monitored. A sound buck is of no use if he will not service does. A full-grown, healthy buck should easily service up to 50 does. Bucks should not be bred to their daughters; inbreeding tends to expose genetic problems and lead to weaker stock.

Some goat producers (especially those who raise dairy goats) use artificial insemination (A.I.) for breeding. This requires excellent heat detection skills and is more labor-intensive than natural service, but A.I. allows the economical use of outstanding sires. The American Dairy Goat Association (ADGA) offers a booklet about A.I., classes are offered by Langston University (Oklahoma) and sometimes by goat associations, and A.I. technicians are available in most areas of the country. For more information, contact your local Extension agent, order the booklet from ADGA (see contact information in the **Resource** section), or call ATTRA.

## Kid Management

Kids are raised for replacement stock, sold as breeding stock, or slaughtered for meat. Therefore, raising healthy, productive kids is essential to the profitability of your operation.

It is crucial that kids receive colostrum (the first milk, which contains antibodies to protect the kid from disease) soon after birth. However, in some herds Caprine-arthritis encephalitis (CAE – see **Health** section) is a concern, and kids



from those herds must be bottle-fed heat-treated colostrum instead of nursing their mothers. Kids raised naturally with their mothers usually grow better than those that are bottle-fed. However, for dairy production, it may be more economical to separate the kids from the mothers, feed kids with a milk replacer, and sell the extra goat milk. It is essential, however, that kids receive colostrum on the first day of their lives.

Males should be castrated at an early age to reduce stress on the animal. Castration with elastic bands should be done within a week of birth. There is some concern that animals may contract tetanus if they are castrated with bands. Male slaughter goats are often castrated, since the meat can have a strong flavor in intact males more than four months old. Some ethnic groups, however, want intact males. It is important for you to know your market, so you can plan for the management of your herd. Disbudding is often done in goat dairies to prevent problems with horns in the milking parlor. Kids are disbudded between three and seven days after birth, using a specially designed disbudding iron that is very hot. Equipment and instructions for use are offered by goat supply houses (see **Resource** list).

## Health Concerns

Few diseases afflict goats, and most producers find even fewer health problems when they use management intensive grazing. Practitioners of MIG see their goats at every paddock move. Observation is the best way to avoid, or at least catch early, any diseases or other problems that might occur.

When people buy goats, they should proceed cautiously.

- Check out the seller's herd.
- Ask the seller questions.
- Learn as much as they can about goats and goat diseases.
- Decide what diseases or problems they can or cannot live with, or which ones they are willing to vaccinate for or treat.
- Know what can or cannot be treated and the consequences of getting the disease in their herd.

Keeping livestock as stress-free as possible keeps their immune systems functioning properly. A healthy immune system is the best disease preventive. Conversely, periods of stress, such as weaning or transporting, may trigger disease. Intensively managed livestock become calmer and tamer, and handling them calmly makes them easier to work with when things such as loading, vaccinating, or other tasks need to be done.

Preventive management is fundamental to maintaining health. Proper nutrition, sanitation, and ventilation, as well as timely treatment or culling of problem animals, helps keep the herd in good health and reduces health care costs. For example, the teats of milking does are usually dipped in disinfectant after milking, while the teat opening is dilated, because bacteria

### Recommended Vaccination Program

Enterotoxemia and tetanus— <i>Clostridium perfringens</i> types C, D, + Tetanus Toxoid in one vaccine	
Adult Males	Once a year
Breeding Females	Once a year (4 to 6 weeks before kidding), or twice a year: 4 to 6 weeks before breeding, then 4 to 6 weeks before kidding
Kids	Week 8, then booster on week 12



entering the teat can cause mastitis. Likewise, regular foot-trimming helps prevent footrot and lameness. Having a good predator control strategy (such as a guardian animal and an electric perimeter fence) will also help prevent losses in your herd.

Check with a local veterinarian to get recommendations for a vaccination and health maintenance schedule for your goat herd. Because so few medications are approved for use in goats, it is imperative to work closely with a veterinarian who can advise you on proper drug use and withdrawal times. It is important to find a veterinarian who is compatible with you and with your management style, and who knows (or is willing to learn) about small ruminants. With time and patience, your veterinarian can become competent in the diagnosis and treatment of small ruminants. You may locate a small ruminant veterinarian by contacting the Association of Small Ruminant Practitioners at <[www.aasrp.org/](http://www.aasrp.org/)>. (See **Resources:** Organizations.)

In many areas, veterinarians recommend vaccinations for tetanus and enterotoxemia (overeating disease). Certain selenium-poor regions require the use of a selenium and vitamin injection several times a year. In other areas, additional vaccines or injections may be necessary for

other diseases or deficiencies. Your veterinarian can help you set up a vaccination protocol that will protect your herd from some diseases that are problems in your area.

## Parasites

Parasites, especially internal ones, are the major health concern for goats. Not only are goats very susceptible to internal parasites, but the parasites are rapidly becoming resistant to all of the available anthelmintics (dewormers), and no new dewormers are being developed. Therefore, management **MUST** be the primary method for sustainable control of internal parasites in goats.

If ample pasture is available and goats are not overstocked, a herd may have little difficulty with internal parasites. However, forcing goats to graze close to the ground and overcrowding stock will cause an increase in parasite load. Animals on highly-stocked pastures will usually carry a heavier parasite load, due to the increased amount of fecal matter on the pasture. You can reduce parasite problems by having a low stock density and by rotating your animals to different pastures. An understanding of how

parasite infestations happen will help to avoid major problems.

All parasite infestations occur when the animal ingests the infective larval stage from contaminated pasture, hay, or living quarters. The larvae develop from eggs that were passed from an animal through its feces. If there are no adult worms in any goats in your herd, this infestation cannot occur. Even if larvae are present in the pasture, goats are less likely than other ruminants to consume them, because goats prefer to eat at eye-level, and the larvae do not climb up grass blades to eye level. This is one of several good reasons for managing pastures to prevent grazing them too short. Try to maintain a forage height above 4 inches, at minimum.

Symptoms of a parasite problem include weight loss, rough coat, depression, and anemia (evidenced by pale mucous membranes, especially in the lower eyelid or gums). Animals that are carrying a heavy parasite load will produce less and lag behind their herd mates. It is important to realize that heavily infected animals are “seeding” the pastures with parasite larvae, thus amplifying the problem over time by contaminating the environment. Also, there is a great deal of variation in individual animal resistance to parasites. Culling animals with severe parasite problems will decrease the herd’s problems by reducing pasture contamination and by retaining and encouraging parasite-resistant genetics in the herd.

A clinical on-farm system called FAMACHA© was developed in South Africa for classifying animals into categories based upon level of anemia. This is done by monitoring the color of the lower eyelid on a scale of 1 (healthy color, no treatment needed) to 5 (very pale, anemic). A special colored card is used to determine the

score. The system recommends anthelmintics or culling for animals scoring 5 or 4 and sometimes 3. Keep records and use those individuals with fewest parasite problems for breeding, while those with the most problems should be culled. This selects for parasite resistant animals. The FAMACHA© system is only useful in detecting those animals infected with barber-pole worms (*Haemonchus contortus*), which is the primary species that causes problems in goats and sheep. The FAMACHA© system is now available in the United States through the Southern Region USDA-SARE (Sustainable Agriculture Research and Education) group, which tested the system in the United States. Only veterinarians or properly trained sheep and goat producers will be able to purchase the FAMACHA© charts. Veterinarians may inquire about FAMACHA© by contacting <famacha@vet.uga.edu>. A Web site is being developed by the SARE group. In the meantime, further information can be found at <<http://scsrpc.org/SCSRPC/FAMACHA/famacha.htm>> .

Another way to assess the parasite load in your herd is to have a veterinarian check fecal samples for parasite eggs and recommend an appropriate dewormer, if necessary. Since very few anthelmintics are approved for goats, and since many parasites have developed resistance to anthelmintics, the help of a veterinarian is essential to administering effective anthelmintics. For milk-producing goats, it is necessary to consider the withdrawal period that a chemical dewormer may require (in order for the goat to be free of residues) before the milk can be sold for consumption. Be sure to reworm three weeks after the initial treatment to kill any parasites that were ingested the day of the first worming. (It takes three weeks for larvae to mature to adult

The main points to keep in mind about parasite control in goats are that your best defense is

- 1) good pasture management, including use of browse as a forage source, and
- 2) selecting parasite-resistant animals (culling those that suffer most from parasites).

No dewormer will compensate for poor management, and many dewormers are no longer effective in the United States. New dewormers for goats are not being developed, so we must learn to control parasite problems through good management and selection of resistant animals.



worms.) Worming and then moving the goats 24 hours later will leave behind the vast majority of contaminated feces. Pastures are considered “clean” if goats or sheep have not been grazed on them for 12 months, or if they have been hayed or rotated with row crops. In the meantime, cattle or horses may be grazed in the infested area, because they do not carry the same species of worms. Goats and sheep, however, do share the same parasites.

Researchers have found that plants with high tannin levels show anthelmintic properties. The tannin in sericea l1\espedeza has been shown to suppress the egg laying ability of adult worms and inhibits the hatching of eggs that are shed.(Min et al, 2004) This reduces the worm load on the pasture and in the animals. Other plants, including wormwood, may also have anthelmintic properties. Allowing the animals to graze on a variety of plant species will assist in providing better nutrition, and may also help with controlling internal parasites. Not all plant species have been evaluated to determine whether they have anthelmintic properties. In the future, more research may be done in this area.

The complete eradication of livestock pests is not feasible or economically necessary – some level of pests may be tolerable. Goats, like other species of livestock, may develop some immunity to worms, making a low-level infestation sometimes more advantageous than no parasites at all. Lack of immunity is very damaging to Angoras, for example. When they are moved from arid range conditions, where there are few internal parasites, to more humid areas, where parasite populations are higher, serious problems often develop. Some individual goats have a higher natural immunity than others, and those are the animals that you should select. Young goats will be most susceptible to parasites and should always be weaned to a clean pasture.

Coccidiosis, a disease resulting from infection of the intestinal tract by parasitic protozoa called coccidia, causes scours (diarrhea) in goats, particularly in kids. There are several coccidiostats (anti-coccidia medications) on the market, but again, management is key for control. Coccidiosis occurs in damp, crowded areas. Keeping kids away from those areas prevents serious problems. Animals gain immunity to this organism by nine months of age, and clinical disease rarely occurs in adult animals.

See ATTRA’s *Integrated Parasite Management*

for *Livestock* for more information on managing parasites.

## Caprine arthritis-encephalitis

Caprine arthritis-encephalitis (CAE) is the most serious disease facing the goat industry. It is an incurable viral infection that causes arthritis, a hardened udder that produces no milk, and a general wasting away. There is currently no vaccine for the disease, and the only way to avoid its devastating effects is to prevent animals from becoming infected. To keep your herd free of CAE, cull any animals that have tested positive for CAE or are showing signs of the disease.

The most common route of transmission is through the milk, although saliva and possibly semen are two other routes. Heat-treating colostrum and pasteurizing milk will kill the virus, and these are the only known ways of preventing the infection from passing to uninfected kids. Producers who implement a CAE-prevention program face a rigorous regimen that includes observing all births, preventing kids from nursing, feeding heat-treated colostrum and pasteurized milk, and segregating or culling all CAE-positive animals. This is a very labor-intensive method of kid rearing. Anyone purchasing a goat should ask how the goat kid was raised and whether it has had recent CAE blood tests. Because some goats do not seroconvert to CAE-positive for two years, a single negative blood test is not necessarily reliable. When kids are bottle-raised on non-pasteurized milk, the milk is usually pooled for all kids, so that one positive doe can have a disastrous effect on a goat herd’s CAE status. Goat producers who are really conscientious about ridding a herd of CAE will not allow infected goats to have any contact with non-infected goats. It is always easier to purchase non-infected animals than to rid your herd of CAE once it is introduced. (When purchasing goats, it is a good idea to look at the entire herd; swollen knees or emaciated animals may be signs of CAE infection in the herd.)

Some CAE-positive goats never show any symptoms of CAE; a good kid producer or a heavy-milking doe that is CAE-positive may still have a place within the herd. The producer should consider the goals and priorities for his or her enterprise before determining whether a goat should be culled on the basis of its CAE status.

At one time, it was thought that only dairy

goats had a high incidence of CAE. However, with so many kids of all breeds being fed infected milk, the situation has now changed. Anyone buying any type of goat must be just as concerned about its CAE status as someone purchasing a dairy goat.

There are tests available to determine whether an animal has CAE. Testing should be done every year. Positive animals should be isolated or culled. Contact your veterinarian or diagnostic lab for further information on CAE testing.

## Abortion

There are several factors that can cause a goat to abort. A deficiency in vitamin A, iodine, or copper can cause abortions. Parasites, certain drugs, poisonous plants, and stress can also cause a doe to abort.

If abortion is widespread in the herd, there is most likely an infectious cause. *Chlamydia psittaci* is the most common cause of infectious abortions. However, there are other organisms that may be the culprit, and treatment depends on knowing the infectious agent. Therefore, at the first abortion in the herd, send the placenta to a diagnostic lab. Keep the placenta chilled until it arrives at the lab. Also be sure to wear rubber gloves and be cautious; some agents can infect humans as well.

Toxoplasmosis is another major cause of abortion in goats. This is a disease that can also infect humans, and it is particularly dangerous to pregnant women. Toxoplasmosis organisms are carried by cats, particularly young cats, which develop immunity once infected. It may help to keep one or two adult neutered cats for rodent control and to prevent other cats from coming onto your farm. Toxoplasmosis is contracted by goats ingesting cat feces. It can be brought onto your farm in hay or straw, if there were cats on the farm where the hay or straw was stored. Certain feed additives (Deccox, monensin) can help prevent abortions due to toxoplasmosis. Consult your veterinarian for details on how and where to ship the placenta and how to treat the herd if an infectious cause is identified. (Patton, 2003)

## Footrot

Footrot is a contagious disease caused by

the combination of two different bacteria, one of which cannot survive outside of the host for more than two weeks. The other is present in the environment. The infection is generally painful and is characterized by limping and signs of pockets of pus on the hoof. There is a strong, foul odor associated with footrot.

To treat footrot, first trim the feet so they are level and smooth (stop when you see pink in the sole, but remove loose bits from the side). Then soak the animal's foot in a footbath containing zinc sulfate or copper sulfate or formaldehyde. Ideally, it should stand in the solution for five minutes and then move to a dry area. (The lot should include dry areas, because mud and moisture will aggravate footrot.)

Animals that do not respond to treatment should be culled. Many producers cull animals by sending them to the sale barn: yet another reason to avoid purchasing stock there. Always observe animals with the herd before purchasing them, and do not buy any animals that limp. Quarantine all new goats for two weeks before putting them with your herd, and watch closely for signs of limping. Consult your veterinarian for assistance in treating footrot and other diseases.

## Caseous Lymphadenitis

Caseous lymphadenitis (CL) infects animals through breaks in the skin, such as cuts or scrapes from shearing, barbed wire, thorny brush, etc., and becomes localized in a regional lymph node, most commonly in or around the neck. The resulting abscess can be either external or internal. Draining or opening an external abscess can cause reinfection. CL is transmitted by direct contact; therefore, all infected animals should be isolated. CL can be picked up in bedding or by touching some other area that has been contaminated by goats with abscesses, and the infectious organism persists in the environment for several months. Internal abscesses occur when the thoracic lymph duct is affected. Animals with internal abscesses often waste away – or they may have no clinical signs. Do not buy any animals from a herd that has abscesses. Diagnostic testing is available to determine whether an animal has CL. Extreme caution must be used when aspirating an abscess, because CL is transmittable to humans. All infected material (gloves, bedding, towels) must be burned to minimize the risk of spreading disease.

## Contagious Ecthyma

This disease, also known as soremouth or orf, is caused by a pox virus. It is characterized by blisters and scabs on the lips and can spread to a doe's udder by an infected nursing kid. This disease is usually introduced into a herd from a purchased animal or one returning from a show. The disease is highly contagious, including to humans, and the virus can live for several months to years in the environment.

There is a vaccine for soremouth, but it should not be used in a herd that is free from the disease. It is a live vaccine, meaning it will introduce the disease into your herd. Usually, if an animal has been infected with the disease, it will be immune to further infections.

## Scrapie Eradication Program

Scrapie is a fatal, degenerative disease affecting the central nervous system, one of the class of diseases known as transmissible spongiform encephalopathies (TSEs). Other examples of TSEs include BSE in cattle and Chronic Wasting Disease (CWD) in deer and elk. There is no evidence that scrapie can spread to humans, but negative public perceptions and the loss of export opportunities have encouraged the effort to eradicate scrapie from the U.S. The incidence of scrapie in goats is extremely low, so it is highly unlikely that your herd will be affected. Nevertheless, goat producers (and sheep producers) are required to participate in the Scrapie Eradication Program. Details about this program are available from your state veterinarian or by going to the National Scrapie Education Initiative Web site, <[www.eradicatescrapie.org/index.html](http://www.eradicatescrapie.org/index.html)>. Briefly, you must contact your state veterinarian to request a premises identification number. You will then receive free eartags with your premises ID printed on them, and you must install tags on any breeding animals over the age of 18 months before they leave your farm. Dairy goat producers may use tattoos instead of ear tags; the state veterinarian will assign an ID tattoo that consists of your state abbreviation and the ADGA tattoo sequence assigned to the farm. In addition, any breeding goat (or sheep) that crosses state lines (for shows or to be sold, for example) must be accompanied by an official Certificate of Veterinary Inspection (health certificate) issued by an accredited veterinarian.

See the **Resource** section at the end of this publication for information on several excellent books on goat health and diseases.

## Flies

In confinement situations, implement fly control programs early in the season, before the fly population gets out of control. A sustainable approach is Integrated Pest Management (IPM). Parasitic wasps are a biological control for barn flies. These wasps lay their eggs in fly pupal cases; wasp larvae kill the developing flies by feeding on them. Light traps, baited traps, and sticky tapes are physical controls for barn flies. Because moist manure, spilled feed, and damp bedding encourage fly populations, practicing good sanitation on a regular schedule is important, especially in confinement areas. Eliminate drainage problems that allow water to accumulate. ATTRA has more information on alternative fly control and IPM available on request.

### **The following are the keys to maintaining a healthy goat herd.**

- Buy healthy stock
- Keep animals as stress-free as possible
- Use preventative medicine – good nutrition, sanitation, foot care, vaccinations
- Have a relationship with a veterinarian
- Learn about the major diseases that can affect your herd and how to prevent them
- Be observant and responsive

## Marketing

This section should probably be on the first page, because marketing must be thoroughly researched and planned up-front. Before beginning production, it is essential to know what goat products you are going to sell, and where and how you will market them. Goat meat, which is 50 to 65% leaner than beef, will be either the primary product or, in the case of dairy or fiber enterprises, an important secondary one. Called "cabrito" or "chevon," goat meat is considered a gourmet or health food by some, is popular in areas with certain ethnic populations, and is often processed into products such as sausage or jerky. See ATTRA's *Sustainable Goat Production*:

*Meat Goats and Dairy Goats: Sustainable Production* for more information about goat products and their markets.

It may be possible to establish a niche market through direct marketing. Many consumers would like to buy products that have been raised with a minimum of synthetic chemicals and pesticides. With any agricultural enterprise, it is important to determine market potential before making an investment in production. See ATTRA's *Resources for Organic Marketing, Direct Marketing, and Alternative Meat Marketing* for additional information.

## Certified Organic Production

Certified organic products have found a niche market with growing potential. The U.S. Department of Agriculture released the National Organic Program final rule, effective October 2002, that details the requirements for organic certification. ATTRA has information about the rule and the certification process available on request.

An organic goat feeding program will probably require a combination of organic pasture and purchased organic feed grains. A pasture must be free of synthetic pesticides or other prohibited substances for three years prior to organic certification. Producers may want to request ATTRA's *Organic Livestock Feed Suppliers* Resource List. The major difficulty with organic production of goats may be the issue of how to control internal parasites without recourse to anthelmintics. Cost and availability of organic grains, hay, and bedding may be obstacles to organic production as well.

It is expensive and time-consuming to go through the certification process. Make sure your customers require certification before undertaking it. Refer to *NCAT's Organic Livestock Workbook* for organic requirements.

## Profitability

Unless goat production is just a hobby for you, it is vital to do feasibility and business planning. A feasibility study identifies "make or break" issues that would prevent your business from being successful, and answers whether the business idea makes sense. A feasibility study also provides useful information for the business

plan, especially the marketing section. (University of Wisconsin Center for Cooperatives, 1998) If the feasibility study indicates that your business idea is sound, the next step is a business plan. A business plan is an analysis of how the business will work—your competition, the market, your capital and operating expenses, management and staffing needs, manufacturing process, etc. It is also one of the written documents usually necessary for obtaining a loan. (University of Wisconsin Center for Cooperatives, 1998)

While developing a business plan may take time and effort, it will be well worth the effort in the long run. An excellent tool for developing a business plan is *Building a Sustainable Business: A Guide to Developing a Business Plan for Farms and Rural Businesses*, developed by the Minnesota Institute for Sustainable Agriculture. This publication addresses all the steps of developing a plan, from identifying your goals to implementing your plan. This publication can be viewed at <[www.misa.umn.edu/publications/bizplan.html](http://www.misa.umn.edu/publications/bizplan.html)>. To order a spiral-bound copy of this workbook, contact 802-656-0484, <[sanpubs@uvm.edu](mailto:sanpubs@uvm.edu)>, 800-909-6472, or <[misamail@umn.edu](mailto:misamail@umn.edu)>. As of 2004, the cost is under \$20, including shipping.

Producers can make effective use of labor and other resources by processing together, marketing together, buying in bulk, etc. Cooperatives can also help producers gain better access to funding and technical assistance. The USDA Rural Business-Cooperative Development Service provides technical support for cooperative development. Contact them for a catalog of publications and services (see **Resources**).

## Resources

Many states have Extension publications about goats. Check with your local and state Extension offices for titles available in your state. Your Extension agent may also have information on local markets and sources of stock.

Goat experts at Langston University's E (Kika) de la Garza American Institute for Goat Research are valuable sources of information. This is a goat research program with specialists who are willing to answer questions about all types of goats—dairy, meat, mohair, and cashmere. Langston's Web site is <[www.luresext.edu/goats/index.htm](http://www.luresext.edu/goats/index.htm)>.

The University of Florida Cooperative Extension

sion service has a Dairy Goat Production Guide that is very informative and useful. This publication can be viewed on-line at <<http://edis.ifas.ufl.edu/DS134>>.

Caprine Supply and Hoegger Supply Company both sell goat equipment, including veterinary supplies and equipment for disbudding and tattooing, insemination, and milking and dairy equipment, and more. In addition, they sell many of the books available on general goat production and specialty books on dairy, meat, and fiber goats. A list of books is also provided at the end of this publication, along with contact information for suppliers.

A good way to learn about goats is from other producers, either formally or informally. Some farms provide internship opportunities. See ATTRA's *Internships and Apprenticeships* Resource List at <[www.attrainternships.ncat.org/](http://www.attrainternships.ncat.org/)>. There may be an association of goat producers in your area. Associations may focus on a locality, a type of goat, or a particular breed. One way to find an association is to contact your local Extension office. There are goat listserves on the Internet with active producer participation, as well as many sites offering goat information.

## Web Sites

### Maryland Small Ruminant Page

[www.sheepandgoat.com](http://www.sheepandgoat.com)

*This site provides links to many topics about sheep and goat production and marketing.*

### Cyber Goats

[www.cybergoat.com](http://www.cybergoat.com)

### Goat Connection

[www.goatconnection.com](http://www.goatconnection.com)

### Langston University – E. (Kika) de la Garza American Institute for Goat Research

[www2.luresext.edu/goats/index.htm](http://www2.luresext.edu/goats/index.htm)

### Oklahoma State University

[www.ansi.okstate.edu/breeds/goats](http://www.ansi.okstate.edu/breeds/goats)

### Fort Valley State University

#### Georgia Goat Center Publications–

[www.ag.fvsu.edu/mainpages/publications.cfm](http://www.ag.fvsu.edu/mainpages/publications.cfm)

**Dairy Goat** – [www.aginfo.fvsu.edu/publicat/](http://www.aginfo.fvsu.edu/publicat/)

[commoditysheets/fvsu005.htm](http://commoditysheets/fvsu005.htm)

**Meat Goat** – [www.aginfo.fvsu.edu/publicat/commoditysheets/fvsu006.htm](http://www.aginfo.fvsu.edu/publicat/commoditysheets/fvsu006.htm)

### North Carolina State University – Extension Animal Husbandry (see Meat Goat)

[www.cals.ncsu.edu/an\\_sci/extension/animal/eahmain.html](http://www.cals.ncsu.edu/an_sci/extension/animal/eahmain.html)

### Florida A & M Goat Program

[www.famu.edu/index.cfm?a=goats](http://www.famu.edu/index.cfm?a=goats)

### The University of Maryland's National Goat Handbook

[www.inform.umd.edu/EdRes/Topic/AgrEnv/ndd/goat](http://www.inform.umd.edu/EdRes/Topic/AgrEnv/ndd/goat)

### University of California-Davis

[www.animalscience.ucdavis.edu/facilities/goats/index.htm](http://www.animalscience.ucdavis.edu/facilities/goats/index.htm)

### University of California Cooperative Extension

[www.vetmed.ucdavis.edu/vetext/INF-GO\\_CarePrax2000.pdf](http://www.vetmed.ucdavis.edu/vetext/INF-GO_CarePrax2000.pdf)

### Empire State Meat Goat Producers Association

[www.esmgpa.org/index.cfm](http://www.esmgpa.org/index.cfm)

### Association of Small Ruminant Practitioners

<http://aasrp.org>

### Livestock for Landscapes

[www.livestockforlandscapes.com](http://www.livestockforlandscapes.com)

### BEHAVE–Behavioral Education for Human Animal Vegetation and Ecosystem Management

[www.behave.net](http://www.behave.net)

*Offers managers tools and resources to harness the power of behavior to induce beneficial outcomes on the land.*

### National Scrapie Education Initiative

[www.eradicatescrapie.org/index.html](http://www.eradicatescrapie.org/index.html)

### FAMACHA information

<http://scsrpc.org/SCSRPC/FAMACHA/famacha.htm>

## CD-ROMs

### Multi-Species Grazing and Leafy Spurge

TEAM Leafy Spurge. 2002.  
USDA-ARS Northern Plains  
Agriculture Research Laboratory  
1500 North Central Avenue  
Sidney, MT 59270  
406-433-2020

[www.team.ars.usda.gov](http://www.team.ars.usda.gov)

*This CD provides a variety of useful information about using grazing as an effective, affordable, and sustainable leafy spurge management tool. It contains economic reports, posters, photos, a PowerPoint presentation, an extensive bibliography, and more. A great resource.*

### GOATS! For Firesafe Homes in Wildland Areas

Kathy Voth  
6850 West County Road 24  
Loveland, CO 80538  
[www.livestockforlandscapes.com](http://www.livestockforlandscapes.com)

*This CD/handbook is designed to provide fire managers, communities, and livestock owners information on using goats to reduce fire danger. It includes expected results, and the "hows" of managing animals, choosing treatment sites, developing contracts for services, estimating costs, and starting projects. This is a great CD with some excellent videos.*

## ATTRA Publications

The following publications are available free from ATTRA. Copies can be requested by calling 800-346-9140 or downloaded at our Web site, <[www.attra.ncat.org](http://www.attra.ncat.org)>.

### General

#### Sustainable Goat Production: Meat Goats

*Offers information specific to meat goat production and should be read after Goats: Sustainable Production Overview. It discusses topics that include selection, breeds, marketing, feeding, and profitability. It also includes sample budgets, case studies of farms in Montana and Missouri, and many further resources.*

#### Dairy Goats: Sustainable Production

*This publication is intended for those interested in starting a commercial goat dairy. It discusses the five major considerations to be addressed in planning for dairy goat production: labor, sales and marketing, processing, regulations, and budgeting and economics. It includes production information specific to dairy goats, including choosing breeds and selecting stock.*

#### Small Ruminant Sustainability Checklist

*This checklist is designed to stimulate critical thinking when evaluating a farm that produces sheep or goats. The sustainability of a farm depends on many factors involving farm management, use of resources, and quality of life. The questions in the checklist are intended to stimulate awareness rather than to rate management practices. Use this guide to define areas in your farm management that might be improved, as well as to identify areas of strength.*

## Health

#### Integrated Parasite Management for Livestock

*With parasites developing resistance to all dewormers, and more farmers producing livestock by "natural" methods, there is interest in looking for alternative ways to manage parasite problems. This publication outlines a systems approach to assess and manage the soil, forages, and animals to decrease internal parasites and their effects.*

#### Predator Control for Sustainable & Organic Livestock Production

*This publication focuses primarily on the control of coyotes and dogs, which are the main causes of livestock lost to predation. It discusses management practices, physical barriers, the use of guard animals, and other predator control measures.*

## Forages

#### Assessing the Pasture Soil Resource

*This publication explains how to take a soil sample and an easy way to assess soil biological activity and water infiltration. Assessment sheet included.*

#### Matching Livestock and Forage Resources

*This publication examines how to manage pas-*

tures and grazing animals to make more profitable use of the farm's resources.

### **Meeting the Nutritional Needs of Ruminants on Pasture**

*Impact of grazing management on nutrition, supplemental feeding on high quality pasture, feed profiling, feed budgeting, and matching livestock and forage resources for efficient pasture use are all covered.*

### **Multispecies Grazing**

*This is a brief overview of why multispecies grazing is beneficial, and includes considerations for multispecies management.*

### **Introduction to Paddock Design**

*This presents the basics of paddock design and considerations in fencing and water technology. Many enclosures.*

### **Rotational Grazing**

*This publication examines how to manage pastures and grazing animals to make more profitable use of the farm's resources.*

### **Sustainable Pasture Management**

*This includes managing fertility and pests, grazing systems, conserved forages, maintaining productivity, and additional resources.*

## Marketing

### **Alternative Meat Marketing**

*This is a comprehensive introduction to producer marketing of meat products. It discusses pitfalls, producing and packaging for quality and consistency, direct marketing options, value-added products, food safety and labeling, and niche markets. Contains a list of resources.*

### **Direct Marketing**

*This publication on direct marketing alternatives – with emphasis on niche and specialty markets and value-added crops – features many farm case studies, as well as information on enterprise budgets and promotion/publicity. A new section discusses implications of Internet marketing and e-commerce for agriculture.*

### **Evaluating a Rural Enterprise**

*This publication is for people who already live in*

*rural areas and want to add new enterprises to their operations. Its sections guide the reader in evaluating resources, assessing finances, gathering information, and marketing. It also discusses choosing an "alternative" enterprise and offers further resources.*

### **Holistic Management**

*This is an introduction to holistic management. Holistic management is a decision-making framework that assists farmers and others in establishing long-term goals, creating a detailed financial plan, developing a biological plan for the landscape, and implementing a monitoring program to assess progress toward the goals. Holistic Management helps managers to ask the right questions and guides them in setting priorities.*

### **Keys to Success in Value-Added Agriculture**

*This publication presents, largely in the words of 14 farmers, important lessons they learned in adding value to farm products and marketing directly to consumers.*

### **Marketing Strategies for Farmers and Ranchers (SAN publication)**

### **Adding Value to Farm Products: an Overview**

*This publication introduces the concept of value-added farm products, explains a few of the nuts and bolts for starting a food processing business, and provides resources for additional information.*

### **Value-added Dairy Options**

*This presents considerations for those who want to increase their profitability by bottling milk, making cheese or yogurt, or doing some other processing of their milk. This publication discusses regulations and organic milk certification and offers resources for further information. Call 800-346-9140 to request this publication, since enclosures are available only with the hard copy.*

## **Books**

The following books offer useful information on a wide variety of production and marketing issues. These titles may be available through your local library, or may be requested through inter-library loan. Most of these books will be worthwhile purchases for individuals new to

goat production. Previewing the books at a library is the best way to select the titles that will be most useful to you.

Used copies may be available through on-line services or through other booksellers. Many suppliers of sheep and goat equipment also offer books in their catalogs, and copies are available from the publishers as well.

### **Meat Goats: Their History, Management, and Diseases.**

Mitcham, Stephanie, and Allison Mitcham. 2000. Crane Creek Publications, Sumner, IA. 264 p.

*A well-written combination of the author's personal experiences raising goats, veterinary knowledge (Stephanie Mitcham is a DVM), and a compilation of information from other experts in the field. Includes information about handling systems (hard to find elsewhere).*

### **Small- Scale Livestock Farming: A Grass Based Approach for Health, Sustainability, and Profit.**

Ekarius, Carol. 1999. Storey Books, Pownal, VT. 217 p.

*Not specific to any species of livestock, this book contains farmer profiles and quite a bit of holistic planning and economic information. Very complete in treatment of rotational grazing.*

### **Storey's Guide to Raising Dairy Goats (revised and updated; originally titled Raising Milk Goats the Modern Way)**

Belanger, Jerry. 2001. Storey Books, Pownal, VT. 288 p.

*Very good general book for producers of dairy goats.*

### **Goats and Goatkeeping**

Thear, Katie. 1988. Merehurst Press, London. 176 p.

*Very interesting book for goat producers, geared for the small farm. Covers milk, meat, and fiber. Practical and concise, very similar to The New Goat Handbook, but with added detail.*

### **The New Goat Handbook**

Jaudas, Ulrich. 1989. Barrons Educational Series, Inc., Hauppauge, NY. 93 p.

*A colorful book with many photographs and line drawings. Very interesting and informative.*

### **Goat Husbandry**

Mackenzie, David. 1967. Faber and Faber Ltd., London. 368 p.

*An older book, it can be found in libraries and from sellers of used books. British terminology. Very good reading. A classic.*

### **Angora Goats the Northern Way**

Drummond, Susan Black. 1988. 2nd edition. Stony Lonesome Farm, Freeport, Michigan. 203 p.

*Order from: Stony Lonesome Farm  
1451 Sisson Rd.  
Freeport, MI 49325*

### **Raising Goats for Milk and Meat**

Sinn, Rosalee. 1995. Raising Goats for Milk and Meat: A Heifer Project International Training Course. Heifer Project International, Little Rock, AR. 140 p.

*Written for persons with limited resources, this is a very practical book. Available through Caprine Supply (among other sources).*

### **The Meat Goats of Caston Creek**

Tomlinson, Sylvia. 1999. Redbud Publishing Co., Victoria, TX. 181 p.

*Personal experiences of the author.*

### **Your Goats: A Kid's Guide to Raising and Showing**

Damerow, Gail. 1993. Storey Books, Pownal, VT. 172 p.

*Gail Damerow writes very good books; this one is easy to understand and very informative. Not just for kids.*

### **Natural Goat Care**

Coleby, Pat. 2001. Acres U.S.A, Austin TX. 371 p.

*Order from: Acres U.S.A.  
Austin, TX 78709  
800-355-5313*

*Fascinating book; Australian author pays*



*much attention to nutrition and maintaining health organically.*

### **Goat Medicine**

Smith, Mary, and David M. Sherman. 1994. Lippincott Williams & Wilkins, Baltimore, MD. 620 p.

*This book is recommended as a useful gift for a veterinarian. Very scientific, some of the terminology will only be understood by a veterinarian. Chapter 1 (Fundamentals of Goat Practice) is very helpful to producers as well as veterinarians. Chapter 20 (Herd Health Management and Preventive Medicine) is also very useful to producers.*

### **Sheep and Goat Medicine**

Pugh, D.G. 2002. W.B. Saunders Company, Philadelphia, PA. 468 p.

*A great gift for a veterinarian. A wealth of information for producers and for veterinarians. Knowledge of veterinary terminology will be helpful in using this book .*

### **Goat Health Handbook: A Field Guide for Producers with Limited Veterinary Service**

Theford, T.R. 1983. Printed in collaboration with Agricultural Experimental Station, University of Arkansas. 123 p.

*Available from:*

*International Winrock Publication Sales  
P.O. Box 9363  
Arlington, VA 22209-0363*

### **Building a Sustainable Business: A Guide to Developing a Business Plan for Farms and Rural Business**

DiGiacomo, Gigi, Robert King, and Dale Nordquist. 2003. Minnesota Institute for Sustainable Agriculture, Saint Paul, MN, and the Sustainable Agriculture Network, Beltsville, MD. Available for \$14.00 + \$3.95 S/H by calling 802-656-0484 or 800-909-6472. Publication can also be viewed at <[www.misa.umn.edu/publications/bizplan.html](http://www.misa.umn.edu/publications/bizplan.html)>.

*Business planning is an important part of owning and managing a farm. A business plan helps farmers demonstrate that they have fully researched their proposed enterprise, that they know how to produce their product, how to sell what they produce, and how to manage financial risk. This comprehensive workbook will guide farmers*

*through every step of the process in creating a business plan. Includes many examples from existing farms. This workbook is a bargain.*

### **...May Safely Graze: Protecting Livestock Against Predators**

Fytche, Eugene. 1998. Published by the author. 103 p. To order, write to Eugene Fytche, R.R. #1, Almonte, Ontario. K0A 1A0.

*This book explores how to identify and quantify the predator problem, and includes information on many methods to control the problem, including guard animals, fencing, and management.*

### **Fences for Pasture & Garden**

Damerow, Gail. 1992. Storey Communications, Inc., Pownal, VT. 160p.

### **Sheep Housing and Equipment Handbook**

Hirning, Harvey J., Tim C. Faller, Karl J. Hoppe, Dan J. Nudell, and Gary E. Ricketts. 1994. MidWest Plan Service, Ames, IA. 90 p.

*This book is useful for goats, as well.*

*Can be ordered by visiting  
<<http://www.mwps.org/>>.*

## **Magazines**

### **The Stockman Grass Farmer**

P.O. Box 2300  
Ridgeland, MS 39158  
800-748-9808  
[www.stockmangrassfarmer.com/sgf/](http://www.stockmangrassfarmer.com/sgf/)  
*\$32 per year (12 issues).*

### **Countryside & Small Stock Journal**

W11564 Hwy 64  
Withee, WI 54489  
800-551-5691  
[www.countrysidemag.com](http://www.countrysidemag.com)  
*\$18 per year (12 issues).*

### **The Goat Magazine**

2268 CR 285  
Gillett, TX 78116  
830-789-4268  
830-789-0006 FAX  
[editor@goatmagazine.com](mailto:editor@goatmagazine.com)  
[www.goatmagazine.com](http://www.goatmagazine.com)  
*\$24.00 per year (6 issues). \$5.00 for a sample issue.*

### **Goat Rancher**

Terry Hankins, editor and publisher  
731 Sandy Branch Road  
Sarah, MS 38665  
888-562-9529  
www.goatrancher.com  
\$25.00 per year (12 issues).

### **The Goat Farmer**

An on-line magazine  
\$10 per year.

### **Meat Goat Monthly News**

Ranch Publishing  
P.O. Box 2678  
San Angelo, TX 76902  
www.ranchmagazine.com/mgn.html  
\$25.00 per year (12 issues).

### **Dairy Goat Journal**

W11564 Hwy 64  
Withee, WI 54498  
800-551-5691 (toll-free)  
www.dairygoatjournal.com  
\$21 per year and \$35 for two years.

### **United Caprine News**

P.O. Box 328  
Crowley, TX 76036  
817-297-3411  
www.unitedcaprinenews.com  
\$22.50 per year.

### **Langston University Quarterly Goat Newsletter**

Free quarterly newsletter  
To subscribe, visit <www2.luresext.edu/goats/library/subscription.htm>.

## **Contacts**

### **USDA Rural Business-Cooperative Development Service**

Stop 3250  
Washington, DC 20250-3250  
202-720-7558  
202-720-4641 FAX  
coopinfo@rurdev.usda.gov  
www.rurdev.usda.gov/rbs/coops/cswhat.htm

### **Langston University**

Agricultural Research & Extension  
P.O. Box 730  
Langston, OK 73050  
405-466-3836  
405-466-3138 FAX  
www.luresext.edu/goats/index.htm

### **New England Dairy/Meat Goat and Dairy Sheep Directory**

This directory was developed through the University of Vermont Center for Sustainable Agriculture's Small Ruminant Dairy Project and lists producers, service providers, and resources for farming with dairy goats, dairy sheep, and meat goats in Vermont, New Hampshire, Maine, Rhode Island, Connecticut and Massachusetts. Producers are listed alphabetically by state/town and indexed by breed; service providers are listed alphabetically and indexed by state/town. The directory also lists resources, including programs, associations, and periodicals. The Center suggests a \$5.00 donation per copy to cover copying, shipping, and handling. To order, or for more information, contact the Center at 802-656-5459 or e-mail <sustainable.agriculture@uvm.edu>. You can also mail your order to Center for Sustainable Agriculture, 63 Carrigan Drive, Burlington, VT 05405. Make checks payable to "UVM." No credit card orders.

## **Suppliers**

### **Caprine Supply**

P.O. Box Y  
3301 W. 83rd Street  
DeSoto, KS 66018  
913-585-1191  
800-646-7736 (toll-free)  
www.caprinesupply.com  
Offers Extension Goat Handbook for \$24.00 plus \$5.75 postage.

### **Hoegger Supply Company**

160 Providence Road  
Fayetteville, GA 30215  
800-221-4628 (toll-free)  
www.hoeggergoatsupply.com

**Sydell**  
46935 SD Hwy. 50  
Burbank, SD 57010-9605  
605-624-4538  
800-842-1369 (toll-free)  
www.sydell.com

**Hamby Dairy Supply**  
2402 SW Water Street  
Maysville, MO 64469-9102  
800-306-8937 (toll-free)  
www.hambydairyresource.com

**Billy Goat Gruff**  
P.O. Box 10  
Dunnville, KY 42528  
www.tartergate.com/brands/goat.php

**D-S Livestock Equipment**  
18059 National Pike  
Frostburg, MD 21532  
301-689-1966  
800-949-9997 (toll-free)  
www.dslivestock.biz

## Organizations

**American Dairy Goat Association**  
209 West Main Street  
P.O. Box 865  
Spindale, NC 28160  
828-286-3801  
www.adga.org



**International Boer Goat Association**  
P.O. Box 310  
Bonham, TX 75418  
877-402-4242 (toll-free)  
www.intlboergoat.org

**International Goat Association**  
www.iga-goatworld.org

**American Association of Small Ruminant Practitioners (AASRP)**  
1910 Lyda Avenue, Suite 200  
Bowling Green, KY 42104  
270-793-0781  
www.aasrp.org

## References

Anon. Multiflora rose control. The Ohio State University Extension Bulletin 857.  
<http://ohionline.osu.edu/b857/pdf/b857.pdf>

Drummond, Sue. 1995. Nutrition for angora goats. The Fiberfest Magazine. Vol. 2, No. 4. p. 22-23.

Fredricks, G. 1993. Using Body Condition Score to Evaluate Feeding Management. p. 78. *In*: Proceedings of the 1993 American Dairy Goat Association National Convention, October 1993, Portland, Oregon. Tuskegee University, Tuskegee, AL.

Holcomb, George B. 1994. A Small-Scale Agricultural Alternative: Dairy and Meat Goats. USDA Cooperative State Research Service, The Office for Small-Scale Agriculture, Washington, DC. 2 p.

Luginbuhl, J-M., J.T. Green, M. H. Poore, and J. P. Mueller. 1996a. Use of goats as biological agents for the control of unwanted vegetation. Presented at the International Workshop "Los Arboles en los Sistemas de Producción Ganadera" [Use of Trees in Animal Production systems], Indio Hatuey Pasture and Forage Experimental Station, Matanzas. November 26-29, 1996.  
[www.cals.ncsu.edu/an\\_sci/extension/animal/meatgoat/MGVeget.htm](http://www.cals.ncsu.edu/an_sci/extension/animal/meatgoat/MGVeget.htm)

Luginbuhl, J-M, J. T. Green, J. P. Mueller, and M. H. Poore. 1996b. Meat goats in land and forage management. *In*: Proceedings of the Southeast Regional Meat Goat Production Symposium "Meat Goat Production in the Southeast—Today and Tomorrow." February 21-24, 1996. Florida A&M University, Tallahassee, FL. [www.cals.ncsu.edu/an\\_sci/extension/animal/meatgoat/MGLand.htm](http://www.cals.ncsu.edu/an_sci/extension/animal/meatgoat/MGLand.htm)

Min, B.R., W.E. Pomroy, S.P. Hart, and T. Sahlu. 2004. The effect of short-term consumption of a forage containing condensed tannins on gastro-intestinal nematode parasite infections in grazing wether goats. *Small Ruminant Research*. Vol. 51, Issue 3. p. 279-283.

Mississippi State Cooperative Extension Service. 4-H Club Goat Guide. <http://msucares.com/pubs/publications/p2264.htm>

Mobini, Seyedmehdi. 2003. Georgia Small Ruminant Research and Extension Center, Fort Valley State University. Unpublished presentation at the American Dairy Goat Association National Convention, October 2003.

Patton, Sharon. 2003. Parasitology Department, University of Tennessee. Unpublished presentation at the American Dairy Goat Association National Convention, October 2003.

Pinkerton, F. 1993. Feeding Strategies to Maximize Yield and Composition of Goat Milk. p. 119. *In*: Proceedings of the 1993 American Dairy Goat Association National Convention, October 1993, Portland, Oregon. Tuskegee University, Tuskegee, AL.

Pinkerton, Frank, and Bruce Pinkerton. 2000. Supplemental Winter Feeding of Goats. <http://www.sa-boergoats.com/asp/other/suppl-winter-feeding.asp>

Sedivec, K., T. Hanson, and C. Heiser. 1995. Controlling leafy spurge using goats and sheep. North Dakota State University Extension Service. [www.ext.nodak.edu/extpubs/plantsci/hay/r1093w.htm#goats](http://www.ext.nodak.edu/extpubs/plantsci/hay/r1093w.htm#goats)

University of Wisconsin Center for Cooperatives. 1998. Cooperatives: A Tool for Community Economic Development. University of Wisconsin, Madison, WI.

The ATTRA Project is operated by the National Center for Appropriate Technology under a grant from the Rural Business-Cooperative Service, U.S. Department of Agriculture. These organizations do not recommend or endorse products, companies, or individuals.

**GOATS: SUSTAINABLE PRODUCTION OVERVIEW  
BY LINDA COFFEY, MARGO HALE, AND  
ANN WELLS  
NCAT AGRICULTURE SPECIALISTS  
AUGUST 2004  
©NCAT 2004**

**EDITED BY PAUL WILLIAMS  
FORMATTED BY ASHLEY RIESKE**

The electronic version of **Goats: Sustainable Production Overview** is located at:

HTML  
<http://www.attra.ncat.org/attra-pub/goatoverview.html>  
PDF  
<http://www.attra.ncat.org/attra-pub/PDF/goatoverview.pdf>

**IP 248 / SLOT 153  
VERSION #080404**



# Meat Goats: Sustainable Production

A Publication of ATTRA - National Sustainable Agriculture Information Service • 1-800-346-9140 • [www.attra.ncat.org](http://www.attra.ncat.org)

By Linda Coffey  
NCAT Agriculture  
Specialist  
©2006 NCAT

## Contents

Introduction .....	1
Beginning a Meat Goat Enterprise .....	1
Selection .....	3
Breeds .....	3
Marketing.....	6
Tips for Success .....	7
Breeding Stock.....	8
Grazing for Hire.....	8
Multispecies Grazing ...	8
Stocking Rate.....	9
Case Study 1: Running RR Ranch, Linn Creek, Missouri .....	9
Feeding Meat Goats ...	10
Profitability .....	12
Sample Budgets .....	14
Case Study 2: Smoke Ridge Ranch, Choteau, Montana .....	17
References .....	18
Further Resources .....	19

This publication offers information, case studies and resources specific to meat goat production and is offered as a companion publication to *Goats: Sustainable Production Overview*. The overview discusses general pasturing of goats, supplemental feeding, diseases and parasites, management, marketing, and resources.



*Boer goat. Photo courtesy of the Department of Animal Science, Oklahoma State University, Stillwater, Oklahoma.*

## Introduction

The increasing economic importance of meat goat production in the U.S. can be attributed both to a strong demand for goat meat and to an interest in ecologically sound forms of vegetation control. Many ethnic groups—including Hispanic, Muslim, and Caribbean peoples—enjoy goat meat, called “chevon” by some and “cabrito” by others. Demand is currently about double the domestic production, so there is ample room for expansion. Meat goats fit in well with other enterprises, particularly cattle operations, and may be used to control noxious weeds and brush to improve pastures for other livestock.

Meat goats can be raised with very little supplemental grain and with minimal shelter, and are generally an easy-care animal. The

key management issues for a successful meat goat enterprise are fencing, parasite control, predator control, and marketing. Attention must also be paid to nutrition and to breeding stock selection. While goats are enjoyable to raise and may be profitable, they are not a way to “get rich quick.” As with any farming endeavor, knowledge and skills are essential for success. Prospective producers are well advised not only to read up on the subject, but to find and spend time with a local meat goat producer, and ask lots of questions.

## Beginning a Meat Goat Enterprise

Before committing themselves to meat goat production, prospective producers should investigate market conditions, estimate costs, and work out a rough budget. In some areas, land and feed costs will be higher, increasing the cost of production; in some areas, lack of demand for meat or kids will make marketing more difficult. Economic feasibility will be enhanced if the meat goat enterprise uses land already owned but not fully utilized, such as brushy land on a cattle operation. The presence of a local ethnic population is a plus, as is proximity to processing plants that handle goats.

## Fencing

If the financial prospects are encouraging and the decision is made to proceed, the next step is to install adequate fencing. Cattle fences may be adapted for goats by adding strands of barbed wire (and stays) or by installing offset hot wires inside the fence at about 8 inches high and 6 to 8 inches



away from the fence. Fences must be tight, and attention must be paid to areas with uneven terrain, as gaps can allow goats to squeeze underneath and escape. Goats must be trained to electric fencing, and charges should be maintained at a minimum of 4,000 volts. Eight strands of tight barbed wire or five strands of high-tensile electric or woven wire 47-inches high (topped with barbed wire and with another strand of barbed wire at ground level) will make a good fence.

Woven wire fencing can have vertical stays 10 or 12 inches apart, rather than 6 or 8 inches. This allows horned goats to avoid entrapment. (Harwell and Pinkerton, 2000) Be aware that the larger spacing will allow weanlings to slip through, unless there are offset hotwires attached to the fence. Another popular choice for fencing is a 4x 4-inch woven wire. This keeps animals in, and the openings are small enough to prevent heads getting stuck.



*Conventional ranch fencing is inadequate for containing goats.*



*Although expensive, cattle panels make secure goat fencing.*

## Housing, Pens, and Chutes

Housing needs for meat goats are very simple, and in moderate climates may consist of natural cover such as thick trees and brush or rock ledges. Goats do need protection from rain and from cold wind and snow. A sturdy shed, open to the south, with rear eave height of 4 to 6 feet and front eave height of 6 to 8 feet will help conserve body heat. (The shed will be more difficult to clean out if the roof is this low, however.) For night shelter, allow 5 square feet per goat. If the shed is near the farmhouse, predators may be deterred. One problem with a permanent shed is that constant traffic will keep the ground bare, leading to erosion. A movable shed (on skids) is one possible remedy.



*Cattle panels with a tarp stretched over them provide adequate shelter for goats.*

In addition to a shed, it will be helpful to have a sturdy catch pen, at least 4 feet tall. This pen is essential when handling the goats for deworming, vaccinations, foot trimming, and sorting. Larger operations will benefit from additional facilities. Lynn Harwell, PhD, recommends a working chute, a squeeze chute (headgate), and an alley system.

A working chute should be about 10 feet long, 4 feet high, and 12 inches wide. Longer chutes tend to cause crowding and trampling at the forward end, and should be divided into sections with sliding gates. Also, a series of canvas flaps suspended about halfway down into the chute keeps the goats' heads down and eliminates riding. The sides should be solid. Ideally, for horned goats the chute should be tapered,

### Related ATTRA Publications

Goats: Sustainable Production Overview

Dairy Goats: Sustainable Production

Multispecies Grazing

Predator Control

Integrated Parasite Management for Livestock

Small Ruminant Sustainability Checksheet

Small Ruminant Resource List

Managing Internal Parasites in Sheep and Goats

with the top nearly twice the width of the bottom. To avoid jamming, it helps to mount a vertical roller, about 30 inches in length, at one side of the entrance to the chute. The crowding pen should be half again as long as the working chute and up to 12 feet wide at the open end. (Harwell and Pinkerton, 2000)



Handling system or set of canals and working pens.  
[www.sheepandgoat.com/articles/handling.html](http://www.sheepandgoat.com/articles/handling.html)

Excellent information on goat behavior, as well as fencing, housing, working facilities, and predator control, may be found in the *Meat Goat Production and Marketing Handbook* at [www.sa-boergoats.com/ASP/Meat-Goat-Handbook/Head-meat-goat-handbook.asp](http://www.sa-boergoats.com/ASP/Meat-Goat-Handbook/Head-meat-goat-handbook.asp).

## Selection

Once finances, fences, abundant food sources (browse or pasture), and shelter are ready, it is time to acquire the goats. A small group of goats will provide many learning experiences in the first year or two. The group can easily be expanded as expertise is gained. Since one buck (male) can easily service 25 to 50 does (females), that is a logical herd size to begin with.

Of first importance is the health status of the animals, and it is a good idea to buy all your animals from one reputable breeder, if possible. Examine the entire herd, and be sure they have been managed the way you intend to manage them. Avoid limping animals (see *Goat Production: Sustainable Overview* for a discussion of footrot) and be sure to find out how the goats have been dewormed, and whether they have resistance to any dewormers. Other important features to check out before purchase are udders, teeth, hooves, and overall body

structure. A goat should not be fat. The hair coat should look healthy and shiny. Hooves, teeth, and udders should be sound. Teeth are important for grazing and browsing, and are an indicator of age. Avoid buying animals with broken teeth, or with wide gaps between the teeth. Be aware that each set of mature teeth indicates one year of age; therefore, a doe with four sets of large teeth (eight teeth) is already at least four years old. This should be considered when negotiating price.

It's a good idea to examine the previous kid crop and to look at production records. Twinning percentage and kid survivability are important components of profitability. Weaning weights are also important, and indicate milking ability of the herd as well as growth potential of the kids. Does may kid at one year of age, but producers may choose to grow them out instead of breeding the first year. A doe should certainly kid by two years of age, however. Goats raised "extensively" (on the range or in rough, brushy areas) may not have records. In that case, ask the producer about the kid crop and be alert for individuals with too much body condition (fat) relative to the others. The ones that look the best may be the ones that did not raise kids. Avoid those freeloaders!

## Breeds

Several meat-goat breeds are available in the U.S. The most widely available and the breed best suited to extensive range is the **Spanish** meat goat, also known as the "brush" goat. Most are horned; color and size are variable. Only horned bucks should be used, as naturally polled goats carry a gene for hermaphroditism. Spanish goats are characterized as hardy and adaptable, excellent foragers, and excellent mothers. However, their flighty disposition—if raised extensively—may make them hard to handle, and they are generally slower-growing and lighter-muscled than other types. Some lines of Spanish goats have been highly selected and will be far superior to the average.

**T**winning percentage and kid survivability are important components of profitability.



Spanish goat.

**B**ecause they have been selected for milk production rather than carcass qualities, dairy breeds will not normally produce a meaty carcass.

**Dairy breeds** may be crossed with Spanish goats to produce a larger kid, and the resulting cross will produce more milk. However, the larger udders of the dairy breeds will cause problems in brushy areas. (Mitchell, 1991) Dairy goats' nutritional requirements during lactation are very high, and therefore more supplemental feed will be needed to maintain milk production. Dairy breeds are much calmer than Spanish goats. Because they have been selected for milk production rather than carcass qualities, dairy breeds will not normally produce a meaty carcass (with the exception of Nubians). However, their availability and price can offset the carcass characteristics, and crossbreeding with a Boer-type buck results in a desirable meat animal that is inexpensive to produce.



Nubian goat.



Nubian goat.

**Angora** goats may be raised successfully for meat. However, they are not adapted to cold climates, and are not as prolific as other goats. It is possible to raise them in northern areas—please refer to *Angora Goats the Northern Way*, by Sue Drummond (contact information listed below under **Further Resources**). The University of California Small Farms Center has a good article about raising angoras. *Angora Goats A Small-Scale Agriculture Alternative* can be found at [www.sfc.ucdavis.edu/pubs/brochures/angora.html](http://www.sfc.ucdavis.edu/pubs/brochures/angora.html).



Angora goats.



**Boer** goats can be very expensive, but they grow more rapidly, put on more meat, and have a calmer disposition than other breeds. They are easily recognized by their large, muscular white bodies and red heads. The Boer goat originated in South Africa, and was imported to the United States in 1993. Boer-Spanish crosses perform well, and using a Boer buck on a fine set of Spanish does is a good way to increase the muscle and growth of the kid crop without incurring excessive expense. Boers also cross well on dairy goats. Boer goats are very large; adult does weigh as much as 200 pounds. They will therefore require considerably more feed than other breeds. Boer-cross does are said to be excellent mothers and good milkers. In Montana, Boers have been crossed with cashmere goats, with excellent results. There is a high demand on the West Coast for these goats, and the fleece value (three to four dollars) offsets the shipping cost.



Boer goat.

The **Kiko** is a New Zealand breed selected for survival and growth rate. They are large-framed goats, excellent mothers, and very hardy. The does can wean 45-pound kids with no extra input, and have a high twinning rate. Kikos may be expensive and hard to find. Excellent foragers bred under tough conditions, they are being used successfully in grazing-for-hire businesses. Contact Sylvia Tomlinson (*Meat Goats of Caston Creek*) or An Peischel, PhD, (Tennessee State University), both listed under **Further Resources**, to learn more about Kiko goats.



Kikos with guard dog.

**Tennessee Woodenleg** goats, also known as “Fainting Goats” and “Tennessee Stiff-legs,” are *myotonic*—their muscles become extremely stiff when they are frightened. The attack usually lasts 10 to 20 seconds, and if they are off-balance when it hits they may fall over. This hereditary condition makes the Tennessee Woodenleg very muscular. The breed originated with four individuals brought to Marshall County, Tennessee, in the early 1880s, and the population of the breed is small. (Gipson, no date)



Fainting goat.

**Tennessee Meat Goats** originated from the “Fainting Goat,” but have been selected for heavier muscling and larger size. More information on the Tennessee Meat Goat is available at [www.tennesseemeat-goats.com](http://www.tennesseemeat-goats.com). However, even after selection, most Tennessee Meat Goats grow more slowly and mature to a smaller size than Boer, Kiko, or dairy goats. Several producers have crossed them with Boer goats to improve growth rate. (tatiana Stanton, personal communication)

**B**oer goats can be very expensive, but they grow more rapidly, put on more meat, and have a calmer disposition than other breeds.

### Breed Notes

Whatever breed is chosen for the meat goat operation, strict culling will be necessary to maintain a productive and profitable herd. Emphasis on reproduction, growth rate, carcass quality, and ability to thrive in the environment will be rewarded.

For pictures and further information on all these breeds and many more, see [www.ansi.okstate.edu/breeds/](http://www.ansi.okstate.edu/breeds/). This Web site also includes contact information for various breed associations.

### Marketing

There is currently a strong and increasing demand for goat meat. Domestic slaughter and imports continue to rise annually, and goat meat that was once exported to Mexico, Canada, and the Caribbean is now being consumed in the U.S. The meat is lean, and may appeal to health-conscious consumers,

but the primary purchasers of goat meat are members of ethnic groups, especially Hispanics, Muslims, and various Caribbean and Asian peoples.

The U.S. Census Bureau projects that between 1995 and 2050, Hispanics will account for 57 percent of the immigration into the U.S., and that Hispanics will account for 25 percent of the U.S. population by 2050. The vast majority of Muslims in the U.S. reside in the area stretching from Washington, D.C. to Boston, Massachusetts. Most of the Caribbean immigrants live in Miami, Florida, or New York City. (Gipson, 1999) There are strong Asian, Hispanic, and Muslim populations on the West Coast.

### Seasonal Demands

Peak demands for goat meat occur at Easter, on Muslim holidays, on the 4th of July, and at Christmas. A calendar of ethnic

**T**he meat is lean, and may appeal to health-conscious consumers, but the primary purchasers of goat meat are members of ethnic groups, especially Hispanics, Muslims, and various Caribbean and Asian peoples.

**Table 1: Ethnic Holidays and the Size of Kid Preferred for Feast**

Holiday	Date	Size of Kid
Easter (Western)	April 16, 2006 April 8, 2007 March 23, 2008 April 12, 2009	20 to 50 pounds
Easter (Eastern and Greek)	April 23, 2006 April 8, 2007 April 27, 2008 April 19, 2009	20 to 50 pounds
Independence Day	July 4	20 to 35 pounds (older kids also accepted)
Caribbean holidays	August	60 pound bucks
Start of Ramadan (Muslim)	September 24, 2006 September 13, 2007 September 8, 2008 August 22, 2009	45 to 120 pounds, less than 12 months
Eid al Fitr (Muslim)	October 24, 2006 October 13, 2007 October 2, 2008 September 21, 2009	45 to 120 pounds, 60 pounds optimum
Eid al Adha (Muslim)	December 31, 2006 December 20, 2007 December 8, 2008 November 28, 2009	yearlings, blemish-free

Source: <http://sheepgoatmarketing.info/education/ethnicholidays.htm>

holidays can be found at [www.sheepand-goat.com/articles/ethniccalendar.html](http://www.sheepand-goat.com/articles/ethniccalendar.html) This helpful site includes preferred weights and types of goats for various holidays and ethnic groups, and illustrates how to plan breeding dates in order to produce kids for a special market. An abbreviated version of the holiday information from this site is presented in Table 1.

## Farm Gate

If there are only a few kids to sell each year, and an ethnic population is nearby, “marketing” may mean simply finding one family who likes to have goat meat for the holidays or for a barbecue. Muslims may want to slaughter the animal on-farm for religious reasons. Some Hispanics may prefer on-farm slaughter as well. If the producer agrees to allow this, it will be helpful to provide a few amenities. These may include a hose hooked up to running water, buckets, a flat working surface, and a hanging arrangement (hooks and ropes) to suspend the carcass while skinning. Arrangements must be made for disposal of offal. Check state regulations for information about composting or burial (and to see if on-farm slaughter is allowed).

## Other Options

In addition to sales at the farm gate, there are several channels for marketing meat goats. These include auction yards, private buyers, processors, sales to restaurants or grocery stores, and sales to a marketing cooperative. Prices at auction yards have improved in recent years, but are still dependent on the buyers present. A commission is charged, and the price is out of the seller’s control. There is no advertising cost, and this may be the most convenient way to market the animals.

Private buyers may come to the farm or accept delivery at some other location. They will be re-selling the animals to consumers. The seller has more control over price, but perhaps less security in payment than with other methods of selling. Check out the reputation of the buyer, or ask to be paid in

cash. Bargaining skills will be an asset in this type of transaction.

In certain areas, restaurants and grocery stores with an ethnic clientele will be interested in buying goat meat. A USDA- or state-inspected facility must be used for processing, and it may be a challenge to find such a facility that is willing to handle goats. It requires extra time, patience, and energy to coordinate the activities of processing, delivering live animals to the processor, marketing the carcasses or cuts, and delivering meat to the retailer. However, this system gives the seller more control over price, and therefore may result in higher profits.

## Marketing Cooperatively

Individual producers may wish to organize into a marketing association to increase marketing options. Many buyers are more interested in a large uniform group of animals (lot), and will offer a better price for a lot than for an individual. Contact your local goat association and your Cooperative Extension Service to inquire about existing plans or for help in organizing.

## Tips for Success

Whatever marketing options you pursue, offer a quality product and understand what the buyer prefers. For instance, if the buyer wants 45-pound kids, it will not pay to feed them to 80 or 90 pounds. Also, goats do not marble; extra fat is simply waste, and is very expensive to put on the goat and also expensive to remove from the carcass. To understand what the buyer wants—ask! Also refer to the ethnic calendar and specifications referenced above. Current market information may be found at [www.sheepgoatmarketing.info](http://www.sheepgoatmarketing.info). See **Further Resources** (below) for other websites and publications that will help you to improve your marketing skills. The articles by Tatiana Stanton are particularly informative. You will find those in the “Education” section of the SheepGoat-Marketing.info Web site, under “Methods and Strategies.”

**W**hatever marketing options you pursue, offer a quality product and understand what the buyer prefers.

**B**esides meat and breeding stock, a third potential product of meat goat herds is the service of grazing for vegetation management.

## Breeding Stock

In addition to marketing meat, there is an opportunity to sell the highest-quality kids as breeding stock. This will require good records, research into what breeds are in demand in your area, and skill in advertising. It will also be necessary to have a *realistic* idea of what breeding stock are worth. Caution is highly recommended: the price of breeding stock should be related to the price of the meat animal. According to Charles Bubl, “The rule of thumb in south Texas is that a buck of good lines should cost about five times what a slaughter kid is worth.” (Bubl, 1996) Martin Farris of Double M Meat Goats points out that sires that produce fast-growing kids are worth more to the producer. (Farris, 2001)

## Grazing for Hire

Besides meat and breeding stock, a third potential product of meat goat herds is the service of grazing for vegetation management. For example, Kathy Voth used goats to create fire breaks and help control forest fires in Utah and Colorado. Another goat grazing business is Ewe4ic Ecological Services, run by Lani Malmberg in Wyoming. (Bingham, 1999) (See **Further Resources** for contact information.) Goats can effectively control kudzu, leafy spurge, multiflora rose, knapweed, and many other problem plants. The goats reduce the need for herbicides; increase the diversity of pasture plants, especially grasses; add fertility to the soil; and are able to control weedy areas that are difficult to treat with other methods. For example, steep slopes on water reservoir dams, utility rights-of-way, and fire breaks near urban areas may benefit from the use of goats to control vegetation.

### Word of Caution

A word of caution is in order: goats need good nutrition in order to be productive. If they are being used as land-clearing tools, the producer may need to provide supplemental feed or accept lower weight gains.

There are no standard rates; each contractor must investigate the individual situation and write a bid for each project, based on anticipated costs and desired profit. (Triumpho, 2001) Major factors to consider before attempting to contract your goat herd for land reclamation or fire control services include:

- A competent and reliable herder to oversee the animals and make decisions on when to move them
- Sufficient temporary electric fencing to confine the animals to an area
- Dogs for herding and for guarding
- Transportation costs
- Costs of alternative (competing) methods—chemical, mechanical, or controlled-burn

A useful resource to learn more about the use of goats to reduce fire danger and for other applications is GOATS! For Firesafe Homes in Wildland Areas. This CD-Rom is packed with information and is available by contacting Kathy Voth at [www.livestockforlandscapes.com](http://www.livestockforlandscapes.com).

TEAM Leafy Spurge has created an Informational Resource CD that is very helpful in learning how to use sheep or goats to control leafy spurge, and some of the concepts are applicable to control of other noxious weeds. See the **Resources** section for ordering information.

A handbook addressing the use of sheep and goats to control vegetation will be published in 2006 and can be found on the ASI Web site and on the ATTRA Web site. This handbook, entitled *Prescription Grazing for Vegetation Management*, contains specific guidelines to control various plants and will have information about using goats or sheep in forests, orchards, and grasslands. Using goats in this manner offers another opportunity for income and an environmentally-friendly way to solve some problems.

## Multispecies Grazing

Goats make a valuable contribution to maintaining the productivity of the pastures they

graze, particularly when used in a multispecies grazing scheme. Many cattle producers have found that adding goats to their farm or ranch increases profits while improving pastures. Meat Goat Specialist Jean-Marie Luginbuhl of North Carolina State University believes that “you can add one or two goats per head of cattle without reducing beef production.” Goats and cattle do not normally share parasites, and goats consume plants that cattle avoid. This increases the amount of grass available for the cattle, as the suppression of brush allows more grass to grow. (Kidwell, 2000)

## Stocking Rate

It is generally believed that six mature goats equal one cow on improved pastures and that ten goats equal one cow on browse or brushy areas. When grazing brush, it may be necessary to adjust stocking rates in order to accomplish your objectives. For example, when starting out with a very brushy area it might be desirable to stock two to four goats, or more, per acre. Later, as the brush disappears, some goats may need to be sold while a few (one-half to one goat per acre) are kept to control regrowth. (Hart, 2000)

### Case Study 1: Running RR Ranch, Linn Creek, Missouri

*The following story is a condensed and slightly edited version of an article published in sheep! magazine, June/July 2001. The author is unknown.*

In 1992 Charles Reed of Linn Creek, Missouri, bought some goats to help control brush on his farm. The goats did that job, and more. Reed found that the goats fit in perfectly with his beef cattle operation and increased the productivity of his farm without costing anything. Reed and his wife, Randy Jane, run 100 beef cows and 500 meat goat does on their place today. They have 300 acres of pasture land and another 150 acres of woodland that is grazed. Much of the farm is hilly, rugged uplands with a lot of brush covering. It is typical Missouri Ozarks land and perfect goat country.

On this farm, Charles Reed has discovered, the goats eat for free. “You can run one to three does for each cow-calf unit and not change the stocking ratio,” he said. The goats don’t take feed away from the cattle. Instead, they eat the rough forage that cattle don’t eat, and create better pasture with more grass for the cattle. The kids produced by the goat herd add another 100 pounds or more net production to every stocking unit, he said. It works out about the same as if you were taking a 450-pound calf at weaning and adding another 150 to 200 pounds to the weight of that animal.

“They really work as brush-clearers,” Reed said. “They will clear a place. It is not something that happens overnight, it may take a couple of years, but the job gets done.” Major brush problems on the Reeds’ place were multiflora rose, thorny locust, and oak sprouts. The goats find all those plants delicious. They will also control cedar, which can be a pest, but it takes longer, he said. (Cedar is not one of their favorite foods.) There is a lot of oak on the land. The does flush\* on acorns in the fall—those acorns are their fall protein boost. The goats fight the deer and the squirrels for the acorns, Reed said.

The goats graze year-round. There is no man-made shelter for them, although they do make good shelter use of cedar thickets on the property. The 350 acres of pasture land are improved native pasture with fescue and some legumes. Reed said he does no supplementary feeding for the does. He sometimes uses a creep feeder for the kids in late summer if the forages get short. It is sometimes dry in August and September and the kids need the extra feeding, he said.

The Reeds use Great Pyrenees dogs for predator control. There are six dogs on the farm now and they stay with the goat herd. Most of the fencing on the farm is electric. Three to four wires works well for the goats.

Kids are born on the farm in April and May. Buck kids are banded to castrate them at birth. This is a management practice, not something required by the market, Reed said. They just aren’t interested in trying to cope with several hundred intact, half-grown bucks in the fall. They do not disbud kids. They leave the horns on.

Reed said the markets for kid goats have improved since he started with the animals in 1992. “When we started, we hauled the kids to the auction in New Holland, Pennsylvania,” he said. “That was the place to get good prices for goats. Now even the local goat auctions in this area are bringing good prices. It hardly pays to truck them any more.”

(The complete article may be found in *sheep!* magazine, June/July 2001, p. 16. More meat goat information is also included in that issue.)

\*flush—to gain weight before breeding. This increases ovulation rate, which should increase the number of kids born.

These figures depend on the carrying capacity of the land. Observation and adjustment are necessary. Some producers, including Mr. Jim Willingham of 8 Mile Ranch near Uvalde, Texas, choose to allow the goats to harvest the brush as forage and maintain it as a renewable resource, rather than attempting to kill it.

## Feeding Meat Goats

In order to raise goats at a low cost, the producer must maximize the use of forage. Please refer to the *Goats: Sustainable Production Overview* for general information on pasturing goats.

Feeding of goats cannot be discussed without mentioning the impact of the kidding cycle. Most goats are seasonal breeders, beginning to cycle with the shorter and cooler days of the fall. They will continue to cycle (unless they are bred) every 21 days or so, until days lengthen in late January or February. Since the gestation period is 150 days, this means that goats bred in September will kid in February, while delaying breeding until late November would mean that kids arrive in late April and in May. The time of kidding determines the period of highest nutritional demand, as late pregnancy and early lactation are critical times

for the doe and kid. By manipulating the breeding date, the producer can see to it that those peak needs hit when more forages are available, rather than during months when only harvested feed can be used.

*Caution:* underfeeding during critical times is not a profit-making idea! Neither is feeding large amounts of purchased feed. It behooves the manager to plan the production cycle to avoid both these pitfalls. Be aware of the pattern of forage availability in your area, and try to use pasture or browse as much as possible.

In addition to pasture or browse, it may be necessary at some times of the year to supplement goats with extra protein and/or energy. To do that efficiently, it is important to understand the requirements of the animal and to meet those needs in the most cost-effective manner. The following information is from “Supplemental Winter Feeding of Goats,” by Frank Pinkerton, PhD, and Bruce Pinkerton, PhD. The entire article is located at [www.sa-boergoats.com/asp/other/suppl-winter-feeding.asp](http://www.sa-boergoats.com/asp/other/suppl-winter-feeding.asp).

The Pinkertons simplify feeding decisions by grouping animals into categories, as shown in Table 3.

Class of Goat	Ave. feed intake/day, lb <sup>1</sup>	% Crude Protein	% TDN
Growing doeling, 45 lb <sup>a</sup>	2.4	8.8	56
Growing male kid, 66 lb <sup>b</sup>	2.9	9.0	57
Yearling doe, 90 lb <sup>c</sup>	4.6	10.0	56
3 yr. old doe, 110 lb <sup>d</sup>	5.0	11.7	69
Mature buck, 220 lb <sup>e</sup>	5.3	9.0	55
Dairy doe, 150 lb <sup>f</sup>	7.5	11.6	71

\*Approximations; based on dry matter in the feeds eaten

<sup>1</sup>Calculated on basis of the dry matter in the feeds eaten

<sup>a</sup>Growing at the rate of .25 lb/day

<sup>b</sup>Growing at the rate of .33 lb/day

<sup>c</sup>Yearling female, last trimester of pregnancy and growing

<sup>d</sup>Milking 2 qt/day - enough for twins

<sup>e</sup>Not gaining weight, moderate activity

<sup>f</sup>Nubian, milking 1 gallon/day of 4.0% butterfat

Source: Pinkerton and Pinkerton, 2000

**Table 3: Practical Dietary Recommendations for Feeding Goats**

	% protein	% TDN
Growing kids, dry does, and bucks	9-10	54-58
Pregnant goats	10-11	56-60
Lactating goats	12-13	62-68

Source: Pinkerton and Pinkerton, 2000

“During the warm-season grazing period,” write the Pinkertons, “goats will very likely meet all their nutritional requirements from whatever combination of forages is available; only a trace mineralized salt and possibly some phosphorus would be needed in addition.”

However, in late fall and winter you will probably need to supplement. Here are some options recommended by the Pinkertons, based on their experiences:

1. Provide a few hours of grazing on ryegrass or small-grain pastures.
2. Offer grass hay *ad lib* plus 1 pound of 20 percent protein pellets daily. (Check protein content of hay: if hay is 10-11 percent protein, reduce pellet to 16 percent protein or feed only three-quarters of a pound per day of the 20 percent pellet.)
3. Feed higher-protein hay (12-13 percent) *ad lib*, and provide one-half pound of corn per head per day for pregnant or lactating does. (May need to feed 1 pound per head per day in some cases.)
4. For kids 3-6 months old, use 1 pound of 16 percent protein feed plus grass hay. Older kids can have grass hay plus 1 pound of 14 percent protein feed.

Using these figures, a producer can estimate feed costs. For example, if you plan to begin with 25 does, and in your environment it is typical to feed hay for the months of December, January, February, and March, then it is possible to calculate feed needed for the season:

120 days X 26 goats (does plus buck) X 5 pounds (approximate dry matter required) = 15,600 pounds.

This is on a *dry matter* basis. Convert that figure to *as fed* basis by dividing by 0.9, since hays are typically about 90 percent dry matter.

15,600 divided by 90% = 17,333 pounds of hay.

Goats are notoriously wasteful; add on about 20 percent to allow for waste, which brings the total amount of hay needed to approximately 20,800 pounds, or 10 tons. If bales are 60 pounds each, then each goat will be eating about 13 bales over the course of the winter. Now, how much do bales cost in your area? Price several sources and convert the amount of hay needed to a cost. In my (fictitious) example, if I were buying hay for \$90 per ton, and dividing that cost over the 25 does, I would already have \$36 feed cost per doe.

A word of caution concerning hay: price is not the only consideration. Goats are choosy, and will refuse hay that is not palatable. Look for bright green, leafy, sweet-smelling hay that is free of molds. Gathering a core sample and having it analyzed at a forage testing laboratory is an excellent idea, and will give you vital information for determining the feeding program.

Next, calculate the number of pounds of protein supplement that will be needed for the year. (Remember that this is dependent on the hay’s protein content. It’s a good idea to do this exercise using various scenarios, in order to find the most cost-effective option.)

### Word of Caution

A word of caution concerning hay: price is not the only consideration. Goats are choosy, and will refuse hay that is not palatable.

120 days X 26 goats X 1 pound/day = 3,120 pounds protein supplement for the winter season.

Convert that figure to a cost as well. If energy supplementation is needed as a result of the type of hay used, calculate the number of pounds needed, and the cost.

There will be other costs, such as fencing, pasture expenses, salt, and minerals. Individual situations will vary tremendously when it comes to fencing and pasture expenses, depending on whether or not there is an existing fence that can be modified inexpensively. If ample browse is available, there may not be any pasture expense. To figure a cost for salt and minerals, read a feed tag for “suggested consumption,” multiply by 365 days and by the number of goats consuming the supplement (don’t forget, the kids will be consuming some for several months as well.) For goats, it is best to feed loose mineral; cattle mineral will work, while sheep minerals do not have adequate copper content. Goats need more copper than sheep do. “A suitable level for ration formulation is 10 ppm.” (Smith and Sherman, 1994)

Salt may be fed as a block or loose, or mixed with the feed at 0.5 percent of the complete-ration dry matter. However, according to Mary Smith, DVM, “When salt is used as a vehicle for trace minerals or medications and is fed free choice, it is important that the goat have no other source of sodium (plain salt or bicarbonate of soda) to satisfy its cravings. Goatkeepers who offer a smorgasbord of supplements are ascribing greater nutritional wisdom to the goat than it actually possesses.” (Smith and Sherman, 1994)

Finally, when feeding goats it is very important to observe closely and adjust feeding practices based on how the animals are doing. A ration that looks adequate on paper may turn out to be unpalatable, or may need to be increased due to severe weather conditions, or may be overly generous if the goats are finding plenty of browse. A properly nourished animal will be healthier, and more able to handle stress and bad weather.

An over-fat animal will have a whole set of problems, and will be a drain on the budget as well.

Some areas of the country need selenium supplementation. Check with your local Extension agent, your veterinarian, or goat producers in your area about selenium status. Excess levels are toxic.

## Profitability

One of the key questions to answer before starting an enterprise is, “Will it be profitable?” The answer is largely dependent on the management and the set of individual circumstances. Many sample budgets have been published, and they are useful to help sort out the various categories of expenses that must be considered. As stated previously, meat goats are not a get-rich-quick scheme.

There are some basic principles to keep in mind that will improve the chances for profit. In his article entitled “Experiencing Long-Term Success as a Meat Goat Producer,” Rick Machen, PhD, of Texas identifies four fundamental conditions for success in a livestock enterprise:

1. Must have a viable market for your product.
2. Market price must exceed cost of production.
3. The goal for reproductive performance is at least one merchandisable unit per exposed female. (An admirable goal for an extensive system would be 1.5 kids weaned for every doe bred.)
4. Match genetic potential for growth with productivity of the environment.

Machen includes a table (reproduced here as Table 4) to illustrate the relationship between cost of production and reproductive performance. Clearly, the chances for profitability are far better if costs are kept low *and* does are productive and kids survive.

**O**ne of the key questions to answer before starting an enterprise is, “Will it be profitable?” The answer is largely dependent on the management and the set of individual circumstances.



**Table 4: Relationship Between Cost of Production and Reproductive Performance**

Doe Cost (\$/hd/yr)	Kid Crop Weaned						
	70%	80%	90%	100%	125%	150%	200%
	Breakeven Price, \$/lb*						
10	0.32	0.28	0.25	0.22	0.18	0.15	0.11
15	0.48	0.42	0.37	0.33	0.27	0.22	0.17
20	0.63	0.56	0.49	0.44	0.36	0.30	0.22
25	0.79	0.69	0.62	0.56	0.44	0.37	0.28
30	0.95	0.83	0.74	0.67	0.53	0.44	0.30
35	1.11	0.97	0.86	0.78	0.62	0.52	0.39
40	1.27	1.11	0.99	0.89	0.71	0.59	0.44
45	1.43	1.25	1.11	1.00	0.80	0.67	0.50
50	1.59	1.39	1.23	1.11	0.89	0.74	0.56
60	1.90	1.67	1.48	1.33	1.07	0.89	0.67

\*Assumed market weight: 45lbs. Does bred to kid once a year.  
(Machen, Rick. Experiencing Long-Term Success as a Meat Goat Producer.  
[www.boergoats.com/clean/articleads.php?art=113](http://www.boergoats.com/clean/articleads.php?art=113))

Referring to the example we used above to calculate cost (**Feeding Meat Goats** section), it is easy to see the impact of a winter hay bill of \$35 per doe. By the time all costs were calculated, it would be necessary to have a highly productive and healthy herd in order to show a profit. Contrast that example to Charles Reed, the producer profiled in the case study on page nine, who states that he doesn't offer any supplemental feed to the does, and runs his does with the cattle. Consider ways that you can reduce costs in your situation, while still maintaining productivity of the herd. For example, perhaps by breeding later, your pregnant does can meet most of their needs from spring pasture rather than winter hay. Reducing the herd's nutritional needs for the period from December to March will enable you to maintain the herd on less feed. If you are forced to kid earlier than March, the best option is to figure out some cheaper ways to supplement the herd; for example, in some climates, winter grazing can be provided more cheaply than hay. If our fictitious producer could feed hay only 40 days instead of 120, expenses would be cut dramatically. Be aware that it does no good to skimp on feed during the times of high nutritional demand; the result will be fewer

and weaker kids, reduced milk, more health problems, and fewer pounds of kids to market. After estimating your feed costs based on the nutritional requirements of your herd during the winter, the cost of meeting those needs, and the number of days you will probably require supplementation for your herd, study the table above to figure out the productivity needed to make a profit in your situation.

Further suggestions for improving the odds of success include:

1. Start with good-quality, healthy breeding stock.
2. Avoid high-dollar stock until you have gained experience. This lowers risk as you will inevitably make many mistakes during the first year or two. Don't buy more than you can afford to lose, and don't borrow money to learn the business.
3. Keep expenses to a minimum. This is accomplished by using forages as much as possible, keeping equipment simple, and using the services of a veterinarian to set up a preventive health care plan. (Investigate the possibility of grazing land you don't own.)

4. Maximize income by maximizing the number of animals for sale. This means concentrating on reproductive efficiency (kid crop born) and on keeping the kids alive and well through good nutrition, health care, and predator control.
5. Pay attention to marketing!

## Sample Budgets

Sample budgets are included here to assist the prospective producer in planning and in determining feasibility. Remember that costs are subjective and depend greatly on management and location. Your situation will not correspond exactly to anyone else's.

Lynn Harwell, PhD, presents an excellent discussion of the financial outlook of the meat goat business, at [www.clemson.edu/agronomy/goats/handbook/analysis.html](http://www.clemson.edu/agronomy/goats/handbook/analysis.html). The article includes a sample budget (along with discussion of how it could be made more attractive) and thought-provoking questions. In his example, the goats are calculated to need three pounds of hay for 120 days at \$80/ton, and one-half pound concentrate for 100 days at \$185/ton. When these costs are added to the other variable costs, the total is about \$42 per doe. To that figure, a cost for land and for interest on capital expense must be added. That brings the total cost figure to \$60. Revenues are then calculated on the basis of a 150 percent kid crop. Market kids are sold for \$40, breeding stock for \$65, and culls for \$55. Total revenues per doe: \$76.

The following sample budget is from Langston University in Oklahoma; it was included in "Sustainable Brush Control" by Steve Hart, PhD, published in the proceedings of the Fifteenth Annual Goat Field Day in 2000. Hart writes, "While goats can be profitable, they are not the way to riches. The secret to making money with goats is to spend a minimum amount of money in producing them. Direct sales of animals can also enhance profitability."

Income	
Sell 1.25 kids/doe (1.5 kidding rate -.25 for replacement) Price \$ .80/lb., 50 lb., \$40/kid Income/doe (1.25 kids x \$40)	\$50.00
Income cull does .2 hd x \$25	5.00
Weed and brush control (save in spraying)	Unknown
<b>Total income</b>	<b>\$55.00</b>
Expenses	
Pasture	\$5.00
Fencing	4.00
Health (vaccination and deworming)	4.00
Buck service	3.00
Raising replacement	10.00
Salt and water	2.00
Winter feeding	10.00
Predator control	2.00
<b>Total expenses</b>	<b>\$40.00</b>
<b>Profit/doe</b>	<b>\$15.00</b>

Another budget (Table 5, facing page) was developed by the Department of Agricultural Economics, Oklahoma State University, and presented in the article "Goat Farm Budgeting" by Roger Sahs in the Proceedings of the Fourteenth Annual Goat Field Day. It includes blanks, to encourage producers to research their own estimated costs.

Another enterprise budget (tailored for Minnesota producers) is found at [www.auri.org/research/goatmeat/budget.htm](http://www.auri.org/research/goatmeat/budget.htm). This budget is in worksheet format for the convenience of the user. You must carefully evaluate the assumptions and calculations in any budget to determine the accuracy for your situation.

There are a number of budgets found at [www.sheepandgoat.com/economic.html](http://www.sheepandgoat.com/economic.html). Several of them are Excel files, allowing you to enter in your own numbers and it will do the calculations.

**T**he secret to making money with goats is to spend a minimum amount of money in producing them.

**Table 5: Meat goats 100 head unit, marginal land with heavy brush/woodlands grazing, per-doe basis**

<b>Operating inputs</b>						<b>Units</b>	<b>Price</b>	<b>Quantity</b>	<b>Value</b>	<b>Your Value</b>
Grain						cwt.	3.60	1,288	4.64	
Alfalfa hay						tons	90.00	0.1	9.00	
Vet medicine						hd.	1.50	1	1.50	
Salt and Minerals						lbs.	0.08	10	0.80	
Marketing expense						hd.	2.00	1,256	2.51	
Annual operating capital						\$	0.088	6,033	0.533	
Machinery labor						hr.	6.50	0.787	5.11	
Equipment labor						hr.	6.50	0.57	3.71	
Livestock labor						hr.	6.50	1	6.50	
Machinery fuel, lube, repairs						\$			5.32	
Equipment fuel, lube, repairs						\$			2.01	
<b>Total Operating Costs</b>									41.63	
<b>Fixed cost</b>							<b>Amount</b>	<b>Value</b>	<b>Your Value</b>	
Machinery:	Interest at						9.45%	11.8	1.11	
	Depr., taxes, insurance								2.38	
Equipment:	Interest at						9.45%	77.99	7.37	
	Depr., taxes, insurance								8.35	
Livestock:	Doe goat							62.25		
	Buck goat							4.50		
	Replacement doe							15.00		
	Interest at						9.45%	81.75	7.73	
	Depr., taxes, insurance								5.70	
<b>Total Fixed Costs</b>									<b>32.64</b>	
<b>Production</b>						<b>Units</b>	<b>Price</b>	<b>Quantity</b>	<b>Value</b>	<b>Your Value</b>
Male kids						hd.	60	0.65	38.88	
Female kids						hd.	55	0.45	24.64	
Cull does						hd.	50	0.16	8.00	
<b>Total Receipts</b>									71.52	
Returns above total operating cost									29.89	
Returns above all specified cost									-2.76	
4% doe death loss, 144% kid crop										
10% kid death loss, 20% doe replacement rate										Sahs, 3/4/99
(Sahs, Roger. 1999. Goat Farm budgeting. In: proceedings of the Fourteenth Annual Goat Field Day. April 24. 1999. Langston University. 65-76.)										

**Table 6: Meat Goat Budget, 50 Head Unit, 180% Kid Crop, 10% Kid Death Loss, 20% Doe Replacement Rate, Central Oklahoma Native Pasture, Per Doe Basis.**

PRODUCTION	Unit	Price/Head	Quantity	Total	\$/Head
Male Kids	Head	\$67.32	40.50	\$2,726.00	\$54.53
Female Kids	Head	\$67.32	30.50	\$2,053.00	\$41.06
Cull Does	Head	\$58.23	7.00	\$408.00	\$8.15
Cull Replacement Doe Kids	Head	\$87.50	0.00	\$0	\$0.00
Cull Bucks	Head	\$104.99	0.00	\$0	\$0.00
<b>Total Receipts</b>				\$5,187.00	\$130.75

OPERATING INPUTS	Unit	Price/Head	Quantity	Total	\$/Head
Pasture	Head	\$1.60	1	\$80.00	\$1.60
Hay	Head	\$7.56	1	\$378.00	\$7.56
Grain	Head	\$0.00	1	\$0.00	\$0.00
Protein Supplement	Head	\$22.23	1	\$1,112.00	\$22.23
Salt/Minerals	Head	\$1.80	1	\$90.00	\$1.80
Vet Services/Medicine	Head	\$1.77	1	\$88.00	\$1.77
Vet Supplies	Head	\$3.25	1	\$163.00	\$3.25
Marketing	Head	\$8.50	1	\$425.00	\$8.50
Mach/Equip. Fuel, Lube, Repairs	Head	\$6.20	1	\$310.00	\$6.20
Machinery/Equipment Labor	Hours	\$7.75	0.90	\$349.00	\$6.98
Other Labor	Hours	\$7.75	2.00	\$775.00	\$15.50
Annual Operating Capital	Dollars	7.25%	39.03	\$142.00	\$2.83
<b>Total Operating Cost</b>				\$3,911.00	\$78.22
<b>Returned Above Total Operating Cost</b>				\$1,276.00	\$25.53

FIXED COSTS	Unit	Rate	Total	\$/Head
<i>Machinery/Equipment</i>				
Interest at	Dollars	8.25%	\$88.00	\$1.76
Taxes at	Dollars	1.00%	\$18.00	\$0.36
Insurance	Dollars	0.60%	\$7.00	\$0.13
Depreciation	Dollars	8.25%	\$160.00	\$3.19
<i>Livestock</i>				
Interest at	Dollars	1.00%	\$431.00	\$8.62
Taxes at	Dollars	0.60%	\$73.00	\$1.45
Insurance	Dollars	0%	\$32.00	\$0.63
Depreciation	Dollars	0.00%	\$160.00	\$3.20
<i>Land</i>				
Interest at	Dollars	0.00%	\$0.00	\$0.00
Taxes at	Dollars	0.00%	\$0.00	\$0.00
<b>Total Fixed Cost</b>			\$967.00	\$19.34
<b>Total Cost (Operating + Fixed)</b>			\$4,878.00	\$97.56
<b>Returned Above all Specified Cost</b>			\$309.00	\$6.19

<http://www.luresext.edu/goats/training/budgets.html>

## Case Study 2: Smoke Ridge Ranch, Choteau, Montana

*In closing, the following information is shared by Yvonne Zweede-Tucker, a Montana rancher and goat enthusiast. The story of her Smoke Ridge Ranch illustrates goat production in a western environment.*

"Their love for noxious weeds gives us an advantage in raising meat goats in North-Central Montana, in spite of the challenges of cold, wind, and drought that Mother Nature throws at us, and our distance from chevon (goat meat) consuming populations," says Craig Tucker. Craig and his wife, Yvonne Zweede-Tucker, own and operate Smoke Ridge, a meat goat breeding operation 13 miles north of Choteau, Montana. "Noxious weeds are a significant and increasing problem for cattle graziers in the Northern states, and the goats offer one solution to the ecological challenge. In recent decades, as sheep numbers have declined in Montana, weeds, brush and forbs have proliferated. Because cattle prefer grasses to brush and weeds, woody or thorny plants like multiflora roses and bitter weeds like knapweed and spurge have multiplied. The goats will walk (or rather, run!) through belly-deep grasses to demolish a wild rose bush and will consume knapweed flowerheads with gusto, essentially stopping the spread of the seeds."

Craig is the Junior High School Mathematics teacher at Choteau, and Yvonne also has a "day job," custom-manufacturing bedding and home décor items for upscale furniture stores and interior decorators in Montana and the Northwest. "They say one has to diversify to survive in Montana," laughs Yvonne, "we just do it three ways!" Their "summer" herd of nearly 1,000 does and kids are increasingly away from home during the summer months, one group to a nearby ranch and another group within Smoke Ridge's own Teton County. Both the privately-owned ranch and the county get the benefit of the goats' weed control in return for allowing them to browse on the high-protein weeds, giving Smoke Ridge fast-growing kids and mother goats ready to breed back in the early winter for another "kidding season" the following May. "There are paid-to-graze programs going on all across the country," explains Yvonne, "but as both the ranch and our county are doing a lot of the work involved with the weed programs, we're more comfortable with a feed-for-weed-control swap."

"Other than weather extremes, with winter temperatures dipping past 30 degrees below zero (without calculating wind chill!) and ongoing drought putting a crimp in hay supplies, one of our challenges is the fact that we're producing a meat that is in large demand—thirteen to twenty-four driving hours away." Yvonne goes on to explain what Smoke Ridge and partnering goat ranches are doing to gain economy of scale and beat the high cost of transportation. "We and the dozen or so ranches that have started raising meat goats with our breeding stock are partnering up so that we have the volume, and increasingly, the consistency of product that meat goat buyers want. This way, we can take a full load of 150 animals on a 24-foot double-decked gooseneck trailer to the Pacific Northwest, and fill a quad-decked semi with up to 700 goats for the buyer in California. We don't have any formal organization, we just cooperate, with the hope and objective that all participants are better off working together than they would be on their own."

A year at Smoke Ridge starts with breeding. Target start date is Thanksgiving weekend, when one buck is turned in with each specifically selected group of does. A group will range from 15 to 135 females, (usually 85–90) and the buck is responsible for covering all of them within the four-week period. After Christmas, all bucks are taken from their groups, all does are put back together, and a "clean-up" buck is given one to two additional weeks to catch any does that still come into heat. "We know exactly which does were with which buck, and after kidding is over at the end of May or beginning of June, we know which doe kidded to the main buck she was exposed to or if she was caught by the clean-up buck," Craig explains. "Any buck who 'misses' more than a few of his girls will more than likely be enjoying a trailer ride to a goat-meat-consuming population center."

The goats are fed hay, straw, and whole corn throughout the winter months to give them the protein, energy, and roughage they require for maintenance and gestation. Mineral is always available, as is fresh water and shelter. As the pastures become grazable in the spring, the stored feed is tapered off until the now heavily pregnant does are feeding themselves. Then the onslaught of kidding starts, with a trickle of kids for a few days, then a rush as up to a third of the drop is born within a few days, and then the calmer final two weeks. The kids start traveling with their mothers out to pasture and back to the night-shelters within a few days, and then start to play "wave" in groups of up to eighty kids, running at full tilt to an unspecified spot some distance away, and then back to where they started. Cleated A-frames and wooden power-line spools provide hours of climbing and jumping pleasure for the goats and viewing pleasure for their owners.

Away on weed-control projects for the majority of the summer and into the fall if possible, the goats are brought back to Smoke Ridge's 220 acres by mid-October. The wethers (neutered male kids) are sorted off to go for slaughter, and the does, doe kids, and bucks that are being sold to other ranches as breeding herds are delivered across the U.S. The does and doe kids that will be used by Smoke Ridge to make the next generation of meat goats are evaluated and decisions are made regarding which breeding groups will be formed.

Smoke Ridge started in 1991 with pure Spanish does and Cashmere bucks. Breeding for and harvesting the cashmere (through annual shearing) has given way to a stricter focus on production of quality slaughter kids in the harsh Montana environment.

## Case Study 2 Continued

Yearling does are targeted to produce one kid, and two-year-old-plus does two or more kids, all to be raised on brush and weeds to slaughter weight of 50 to 70 pounds by six months. "All of our goats have the cashmere undercoat which makes them more fuel-efficient and thus more able to survive and reproduce in spite of our cold winter temperatures, but we had to choose a primary focus and simplify our breeding objectives. We're crossbreeding the Boer breed of meat goat, developed in South Africa, with the Spanish does to add carcass quality, but production remains the key. Getting an 80-pound kid is great, except if it's a single from a mature doe who normally gives us two 60-pound kids," Yvonne says. "We want to keep the survivability, longevity, and fantastic maternal traits of the Spanish goat while adding some additional muscling." Even before Boer influence was added, the Smoke Ridge Spanish goats didn't look like their grandmothers anymore. "Our goats are wider and slightly lower than what you'll find in a typical Spanish goat. By keeping records, ear-tagging all progeny, and selecting exclusively for production for years, we've started getting a specific body type."

Guardian dogs see to it that the goats are in no danger from predators. Maremmas, Anatolians, and Maremma-Anatolian crosses stay in the pastures year-round and ensure that the coyotes, eagles, foxes, ravens, and badgers choose a food group other than goat. The dogs clean up afterbirths that the does do not consume, and stay with sleeping kids and solitary does in labor.

Electric fencing (aluminum-clad) defines the goats' permanent pastures, and portable poly-wire with tread-in posts simplifies the task of allocating a portion of larger pastures. Three-sided sheds (16-feet long, 8-feet deep and 4-feet high, open to the south) have only recently been joined by a barn as the goats' sole shelter. Yvonne says, "The goats will bed down outside if it's snowing, and in the morning you'll have dozens of snow-covered lumps with goat heads sticking out of them, chewing their cud; but if it rains, they're under the roofs!" They also hate having to walk through or in water, preferring to use a board or bridge to cross anything they can't jump (2 to 3 feet wide or more).

Smoke Ridge is in the goat business for the long haul and continues to look forward to each "next year." "When I first did the business plan to get goats, in 1990," Yvonne remembers, "I loved the idea that the meat was in short supply, the cashmere was in short supply, and that the weeds that the goats prefer to eat were a real and increasing problem...but I had no idea how much we would come to love them. They are so much fun, and not just when they're little. They are affectionate, playful, and sometimes too smart. They have a really strong herd instinct—where one goes, they all go. They don't share very well, either food or your attention, but if you treat them with respect and kindness, they are very easy to work in sorting facilities and to load and transport."

(Personal communication, Yvonne Zweede-Tucker, 2002)

## References

- Anon. 2001. Missouri rancher finds 500 goats and 100 cattle fit together well. sheep! June/July. p. 16.
- Bingham, Sam. 1999. A Weed Goat Adventure. *Holistic Management in Practice*. November. p. 10-11.
- Bubl, Charles. 1996. Meat Goat Production. *Pacific NW Sustainable Agriculture*. p. 3-5.
- Farris, Martin. 2001. Producing Goats for the Real World. *Goat Rancher*. February. p. 11-16.
- Gipson, Terry A. No date. Meat Goat Breeds and Breeding Plans. *In: Meat Goat Production and Marketing Handbook*, North Carolina. p. 12-18.
- Gipson, Terry A. 1999. Demand for Goat Meat: Implications for the Future of the Industry. *In: Proceedings of the Fourteenth Annual Goat Field Day*, held April 24, 1999. Langston University p. 23-30.
- Hart, Steve. 2000. Sustainable Brush Control. *In: Proceedings of the Fifteenth Annual Goat Field Day*. Langston, OK. p. 32-35.
- Harwell, Lynn. 2000. Enterprise Analysis. [www.sa-boergoats.com/asp/Meat-Goat-Handbook/Enterprise-Analysis.asp](http://www.sa-boergoats.com/asp/Meat-Goat-Handbook/Enterprise-Analysis.asp). 6 p.
- Harwell, Lynn and Frank Pinkerton. 2000. Housing, fencing, working facilities and predators. [www.sa-boergoats.com/asp/Meat-Goat-Handbook/Housing-Fencing.asp](http://www.sa-boergoats.com/asp/Meat-Goat-Handbook/Housing-Fencing.asp).
- Kidwell, Boyd. 2000. Make Money With Goats—No Kidding. *Progressive Farmer*. September. p. 30-31.
- Machen, Rick. No date. Experiencing Long-Term Success as a Meat Goat Producer. [www.boergoats.com/clean/articleleads.php?art=113](http://www.boergoats.com/clean/articleleads.php?art=113). p. 3.

- Mitchell, Elise. 1991. Brush control with goats. The Kerr Center for Sustainable Agriculture, Inc.
- Pinkerton, Frank and Bruce Pinkerton. 2000. Supplemental Winter Feeding of Goats. [www.clemson.edu/agronomy/goats/winter\\_feed.html](http://www.clemson.edu/agronomy/goats/winter_feed.html). 5 p.
- Sahs, Roger. 1999. Goat Farm Budgeting. In: Proceedings of the Fourteenth Annual Goat Field Day. April 24, 1999. Langston University. p. 65-76.
- Smith, Mary and David M. Sherman. 1994. Goat Medicine. Lippincott Williams & Wilkins. Baltimore, MD. p. 538.
- Triumpho, Richard. 2001. Four-footed bushwhackers. The Farrow. January. p. 21-22.

## Further Resources

Many states have Extension publications about meat goats. Check with your local or state Extension office for titles available in your state.

The ATTRA publication *Small Ruminant Resources* includes a list of books, Web sites, and ATTRA publications that are useful to producers of goats and sheep.

## On-line courses

Langston University has an online Goat Production Course. There are 18 modules on topics such as breed selection, nutrition, and health. The modules can be viewed at [www.luresext.edu/goats/training/qa.html](http://www.luresext.edu/goats/training/qa.html). This course can be completed for a Master Goat Producer certificate, or you may browse the course and read individual modules as needed.

Penn State Cooperative Extension offers a Meat Goat Home Study Course. The module topics include basic production, reproduction, nutrition, health, marketing, and financial information. This study course can be found at <http://bedford.extension.psu.edu/agriculture/goat/goat%20lessons.htm>. These courses contain excellent information for those interested in meat goat production.

## Web sites

This is not a complete listing of meat goat resources on the Internet, but it will get you started. These sites all include links to other meat-goat sites.

**tatiana Stanton**, PhD, has written an excellent series of articles and fact sheets that are very helpful to

prospective and experienced producers. These may be found at the Cornell website:

### Starting a Meat Goat Operation

[www.ansci.cornell.edu/extension/marketfact1.html](http://www.ansci.cornell.edu/extension/marketfact1.html)

### On-farm Marketing of Slaughter Goats

[www.ansci.cornell.edu/extension/marketfact2.html](http://www.ansci.cornell.edu/extension/marketfact2.html)

### Marketing Slaughter Goats Through Livestock Market Auctions

[www.ansci.cornell.edu/extension/marketfact3.html](http://www.ansci.cornell.edu/extension/marketfact3.html)

### Ethnic Calendar

[www.ansci.cornell.edu/extension/meatgoat3.html#cal](http://www.ansci.cornell.edu/extension/meatgoat3.html#cal)

### Empire State Meat Goat Producers Association

[www.esmgpa.org](http://www.esmgpa.org)

**Frank Pinkerton, PhD, and Bruce Pinkerton, PhD**, have published some very helpful articles:

### Meat Goat Production and Marketing Handbook

[www.sa-boergoats.com/](http://www.sa-boergoats.com/)

### Housing, Fencing, Working Facilities, and Predators

[www.sa-boergoats.com/ASP/Meat-Goat-Handbook/Housing-Fencing.asp](http://www.sa-boergoats.com/ASP/Meat-Goat-Handbook/Housing-Fencing.asp)

### Managing Forages for Meat Goats

[www.sa-boergoats.com/ASP/Meat-Goat-Handbook/Management-Forages.asp](http://www.sa-boergoats.com/ASP/Meat-Goat-Handbook/Management-Forages.asp)

### Supplemental Winter Feeding of Goats

[www.sa-boergoats.com/ASP/other/suppl-winter-feeding.asp](http://www.sa-boergoats.com/ASP/other/suppl-winter-feeding.asp)

### Enterprise Analysis by Lynn Harwell, PhD

[www.sa-boergoats.com/ASP/Meat-Goat-Handbook/Enterprise-Analysis.asp](http://www.sa-boergoats.com/ASP/Meat-Goat-Handbook/Enterprise-Analysis.asp)

### Enterprise Budget: The Feasibility of Meat Goats in Minnesota

by Jay Lillywhite, PhD

[www.auri.org/research/goatmeat/budget.htm](http://www.auri.org/research/goatmeat/budget.htm)

**North Carolina State University maintains a site with many useful materials on meat goats**

[www.cals.ncsu.edu/an\\_sci/extension/animal/meatgoat/ahgoats\\_index.html](http://www.cals.ncsu.edu/an_sci/extension/animal/meatgoat/ahgoats_index.html)

**Sheep and Goat Marketing**  
<http://sheepgoatmarketing.info>

**The Maryland Sheep and Goat Website**  
[www.sheepandgoat.com](http://www.sheepandgoat.com)

**Langston University E (Kika) de la Garza  
Institute for Goat Research**  
[www2.luresext.edu/goats/index.htm](http://www2.luresext.edu/goats/index.htm)

**For those interested in Boer goats**  
[www.boergoats.com](http://www.boergoats.com)  
[www.jackmauldin.com](http://www.jackmauldin.com)  
[www.goatrancher.com](http://www.goatrancher.com)

**Tennessee Meat Goats**  
[www.tennesseeameatgoats.com](http://www.tennesseeameatgoats.com)

**Kikos**  
[www.kikogoats.com](http://www.kikogoats.com)

**Comprehensive resource on goat breeds, with  
pictures and contact info for various  
breed associations**  
[www.ansi.okstate.edu/breeds](http://www.ansi.okstate.edu/breeds)

**Equity Livestock Auction**  
[www.equitycoop.com](http://www.equitycoop.com)

**Fundamentals of marketing goats**  
[www.ansci.cornell.edu/extension/  
meatgoat3.html](http://www.ansci.cornell.edu/extension/meatgoat3.html)

**Experiencing Long-Term Success as a Meat Goat  
Producer by Dr. Rick Machen**  
[www.boergoats.com/clean/  
articleads.php?art=113](http://www.boergoats.com/clean/articleads.php?art=113)

**The Biology of the Goat**  
[www.imagecyte.com/goats.html](http://www.imagecyte.com/goats.html)

## **Magazines**

**Goat Rancher**  
Terry Hankins, Editor and Publisher  
731 Sandy Branch Road  
Sarah, MS 38665  
662-562-9529  
[www.goatrancher.com](http://www.goatrancher.com)  
\$25/year, 12 issues.

**Dairy Goat Journal**  
Dave Belanger, Publisher  
Countryside Publications, LTD.  
145 Industrial Drive  
Medford, WI 54451  
[www.dairygoatjournal.com](http://www.dairygoatjournal.com)

*\$21/year, published bimonthly. Focused on dairy goats, as the title implies, but contains some information on meat goats as well.*

**Ranch and Rural Living and Meat Goat News**  
P.O. Box 2678  
San Angelo, TX 76902  
915-655-4434  
*\$25/year, 12 issues; \$48/year for both publications. Publications of the Texas Sheep & Goat Raisers' Assoc. [www.ranchmagazine.com](http://www.ranchmagazine.com)*

## **Books**

**Goat Medicine**  
Smith, Mary and David M. Sherman. 1994.  
Lippincott Williams & Wilkins  
Baltimore, Maryland

**The Meat Goats of Caston Creek**  
Tomlinson, Sylvia. 1999. 181 p.  
Redbud Publishing Co.  
P.O. Box 4402  
Victoria, Texas 77903  
[info@redbudpublishing.com](mailto:info@redbudpublishing.com)

**Angora Goats the Northern Way**  
Drummond, Susan Black. 1988. 2nd edition.  
203 p.  
Stony Lonesome Farm  
1451 Sisson Rd.  
Freeport, Michigan 49325

**Angora Goat and Mohair Production**  
Shelton, Maurice. 1993. 233 p.  
Anchor Publishing Co.  
221 N. Main St.  
San Angelo, Texas 76903

(More books are listed in the *Small Ruminant Resources* publication; call ATTRA at 800-346-9140 to request a free copy.)

## **Contacts**

Lani Malmberg  
768 Twin Creek Rd.  
Lander, WY 82520  
970-219-0451  
[www.goatapelli.com](http://www.goatapelli.com)

Dr. An Peischel  
Tennessee State University  
3500 John A. Merritt Blvd.  
Box 9635  
Nashville, TN 37209



615-963-5539

*apeischel@tnstate.edu*

Sue Drummond

Stony Lonesome Farm

1451 Sisson Rd.

Freeport, MI 49325

Craig Tucker & Yvonne Zweede-Tucker

Smoke Ridge Ranch

2870 Eighth Lane NW

Choteau, MT 59422-9122

406-466-5952

*smokeridge@marsweb.com*

## Acknowledgements

Special thanks are due to Tatiana Stanton, PhD, of Cornell University, and to Yvonne Zweede-Tucker of Smoke Ridge Ranch, Choteau, Montana. Both reviewed and suggested changes to this publication. I appreciate their time and expertise. Thanks also to NCAT/ATTRA staff members who provided assistance and support, especially Margo Hale.

# NOTES

# NOTES

**Meat Goats: Sustainable Production**

By Linda Coffey  
NCAT Agriculture Specialist  
©2006 NCAT

Paul Driscoll, Editor  
Cynthia Arnold, Production

This publication is available on the Web at:  
[www.attra.ncat.org/attra-pub/meatgoat.html](http://www.attra.ncat.org/attra-pub/meatgoat.html)  
and  
[www.attra.ncat.org/attra-pub/PDF/meatgoat.pdf](http://www.attra.ncat.org/attra-pub/PDF/meatgoat.pdf)

IP200  
Slot 185  
Version 082106

# DAIRY GOATS: SUSTAINABLE PRODUCTION

LIVESTOCK PRODUCTION GUIDE

**Abstract:** Dairy Goats: Sustainable Production is intended for those interested in starting a commercial goat dairy. It discusses the five major considerations to be addressed in planning for dairy goat production: labor, sales and marketing, processing, regulations, and budgeting and economics. It includes production information specific to dairy goats, including choosing breeds and selecting stock. A resource list for further information about dairy goat production follows the end notes.

This is a companion piece to ATTRA's *Goats: Sustainable Production Overview*. The *Overview* should be read first, since it contains production information for goats in general, including grazing management, fencing, reproduction, nutrition, diseases and parasites, and resources.

## Contents

Introduction .....	1
Getting Started.....	2
Labor .....	2
Marketing .....	3
Processing.....	3
Farm Profile:	
Split Creek Farm,	
South Carolina .....	5
Regulations.....	5
Budgeting .....	7
Production	
Notes .....	10
Selecting stock.....	10
Farm Profile:	
Redwood Hill	
Farm, California.....	14
Feeding.....	15
Milking.....	18
Health.....	21
Conclusion .....	24
Farm Profile:	
Blufftop Farm,	
Arkansas.....	25
Resources.....	26
References .....	30

By Linda Coffey, Margo Hale,  
and Paul Williams  
NCAT Agriculture Specialists  
© 2004 NCAT



## Introduction

In 1994, world-wide production of goat milk was approximately 10.5 million tons. In the United States at that time, there were approximately one million dairy goats producing 600,000 tons of milk, about 300 known dairy goat businesses, and at least 35 known commercial goat-cheese makers. These cheese makers produced about 640 tons of U.S. goat cheeses, while at least another 650 tons of goat cheese were imported that year from France alone. (Haenlein, 1996)

Dairy goats are enjoyable animals, easy to handle and haul, and relatively inexpensive to purchase, feed, and house. Dairy goat production, especially pasture-based production, offers the opportunity for profitable and sustainable diversity on a small farm. For example, a vegetable farm can use goats to clean up residue and fertilize the land, while producing milk for the family or for raising kids, calves, pigs, or other livestock. Goats will browse and help keep pastures from being overrun with woody species.

In some locations, Grade A dairies may have a market for fluid milk. Goat milk can often be enjoyed by people who are allergic to cows' milk, and infants of all species generally thrive on goat milk. Value-added products such as cheese and yogurt made from goat milk are finding a growing acceptance in the dairy market, with sales of goat cheese increasing more than 16% in 2000. (Specialty Cheese Market, 2001)

However, producing dairy animals and dairy products requires a great commitment of time and energy and consistent attention to detail. Proper nutrition and milking procedures,

skillful kid raising, and good general health care are essential for success. In addition, costs must be kept under control. Most important of all is marketing; a viable business requires a healthy demand for the product or products produced and a price that allows a profit.

Because commercial production is so much more challenging than keeping a few dairy goats, this publication will first address the major issues of labor, marketing, processing, regulations, and budgeting. The production notes— including selecting stock, feeding, breeding, and milking— compose the second major section. Finally, budgets and a list of further resources are also provided.

## Getting Started

Things to be considered before entering a commercial dairy goat business include the availability of labor, the marketing outlook, processing options, regulations, budgeting, and economics.

### Labor

Labor is a major concern. Do you enjoy goats enough to spend mornings and evenings, seven days a week, week after week, feeding, milking, and cleaning up? Do you have the support of your family in this? Many dairy producers have faced frustration and burnout after trying unsuccessfully to hire competent help. If your family is not willing to help with the business, you should probably consider a less demanding enterprise.

Estimates vary regarding the labor demands of a goat dairy. Dr. Robert Appleman believes that a 100-doe dairy selling fluid milk to a processor will require about 1.5 full-time workers. (Appleman, 1989) Appleman's calculations:

- Milking: 25 does/person/hr (305 days)
- Set-up and clean-up: 40 min. daily
- Manure handling and bedding: 25 min. daily
- Feeding hay and grain: 30 min. daily
- Heat detection: 30 min./day for 6 months
- Breeding: 20 min. x 2 breedings
- Miscellaneous: .5 min. daily per doe

Some of the above figures are per doe, while others are per herd. Total labor per doe in

### Related ATTRA publications

*Goats: Sustainable Production Overview*

*Sustainable Goat Production: Meat Goats*

*Small Ruminant Sustainability  
Checksheet*

*Rotational Grazing*

*Sustainable Pasture Management*

*Integrated Parasite Management for  
Livestock*

*Predator Control for Sustainable & Organic  
Livestock Production*

*Value-added Dairy Options*

*Assessing the Pasture Soil Resource*

*Dung Beetle Benefits in the Pasture  
Ecosystem*

*Grazing Networks for Livestock Producers*

*Matching Livestock & Forage Resources in  
Controlled Grazing*

*Multispecies Grazing*

*Nutrient Cycling in Pastures*

*Introduction to Paddock Design & Fencing—  
Water Systems for Controlled Grazing*

Appleman's budget is 34.7 hours per year, 70% of which is spent milking. (Appleman, 1989)

In contrast, a Pennsylvania State University budget estimated labor as 22 hours per doe per year to run a 100-doe facility (Penn State, <http://agalternatives.aers.psu.edu/livestock/dairygoat/budget1.htm>), while another budget considered 13.6 hours per doe per year to be sufficient for a 100-doe herd. (Rutgers Cooperative Extension, <http://aesop.rutgers.edu/~farmmgmt/ne-budgets/organic/DAIRY-GOAT-1500LB-MILK.HTML>) With so much variation in estimates, you may want to visit a producer who has a dairy the size you intend to operate, work beside the farmer for a week or so if possible, and ask what that farmer thinks is realistic. Facilities and efficiency of milking, feeding, and cleaning can account for a lot of the difference, and that should be kept in mind as you plan your dairy farm. Also, note that these figures do NOT include any value-added processing or marketing time; if on-farm processing is part of your business, labor costs will be significantly higher.

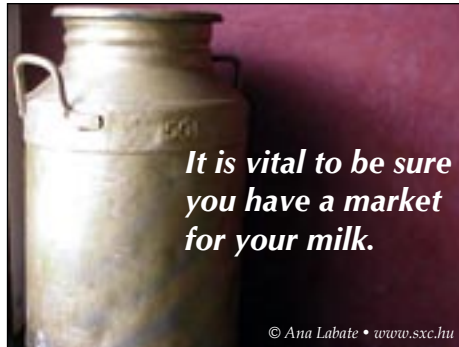

## Marketing

If labor is available, the next concern is marketing. What product or products do you hope to sell? Is there an unmet demand for that product in your area? If so, what price can you realistically expect to receive? Can you make a profit if you sell at that price?

In the case of fluid milk, a prospective producer must first locate a reliable buyer. Judy Kapture, long-time producer and columnist for the *Dairy Goat Journal*, issues a strong warning to the farmer planning to start a goat dairy.

You are certainly wise to be cautious. I can tell far too many stories about people who used all their money to set up their farm as a goat dairy, and then never did sell any milk. Or their milk market fizzled out within a year... Get in touch with them (the buyer) to find out if they actually are planning to buy more milk. Learn the details – how much milk do they want from a farm, what do they pay for milk, is winter production a necessity, what do they charge for hauling, etc.

Then talk with some of the people who are shipping milk to them now. You want to find

out if they feel the pay for the milk is good enough to make the goatkeeping effort worthwhile. (Remember that feed and other costs vary greatly and a “good milk price” in one area may be too low for another.) You may get some surprises when you ask this question... Be cautious about new startups. Sometimes they have a lot of enthusiasm but no idea how difficult it will be to market their milk or cheese or other product in the quantities they need... Are there patrons shipping milk to the buyer now? Talk to them, all of them. Are they getting paid? Is the buyer taking all the milk he promised he would?... How good is the market for what they are planning to sell? (Kapture, 2001)

In many areas of the United States, there are no processors. In some areas, a processor is available but already has enough milk producers on contract. Therefore, it is vital to be sure you have a market for your milk. If you are unable to sell to a processor, it may be feasible to sell to individuals raising baby animals, or to market the milk through your own livestock (raising calves, for example, and selling them for meat). In some areas it is possible to sell milk directly to individuals for

human consumption, but in MANY states that is ILLEGAL. To find out what is legal in your state, contact the agency responsible for dairy regulations. The American Dairy Goat Association (ADGA) lists the contact information for state agencies on its Web site, [www.adga.org](http://www.adga.org). Go to “Starting a Grade A or Grade B dairy,” [www.adga.org/StartDairy.htm](http://www.adga.org/StartDairy.htm).

Marketing to individuals will require much more time and effort and will be harder to initiate. For example, a milk truck going to a commercial dairy may pick up 200 gallons of milk every other day. If there is no milk truck, how much milk can you sell each week? If the answer doesn't equal “all of it,” what will you do with the rest? The available market is a major factor in determining your scale of operation (herd size).

## Processing

Some producers choose not to deal with a milk buyer and hope to increase their farm profits by processing the milk themselves. Diversifying the products you sell may offer more income and financial stability. Those products might include

fluid milk, milk-fed pork, goat cheese of one or more varieties, yogurt, fudge, goatskins, meat, or goat-milk soap or lotions.

Cheese is a good alternative to selling milk, particularly if you like direct marketing. It is legal to use raw milk in making cheese if the cheese is aged at least 60 days before sale. (Dairy Practices Council, 1994) Fresh cheese must be made with pasteurized milk. Cheesemaking classes will prove helpful, and much practice, experimentation, and sampling will be necessary before you are ready to market farmstead cheese. You must abide by regulations (talk to your inspector about what is involved). Cheese-making resources are discussed in *The Small Dairy Resource Book* (see **Resources: Contacts**), and Caprine Supply and Hoegger Supply Company (see **Resources: Suppliers**) offer several books about cheesemaking.

Edible products will require a Grade A dairy, commercial kitchen, and licenses (contact your state agency for more details), while soap making does not. Soap is non-perishable, easy to ship, and does not require much milk. These advantages make soap an appealing option for small farm enterprises.

Any further processing (beyond selling bulk fluid milk) will create extra demands on the farmers, since they must somehow tend not only to the dairying but also to the processing, packaging, marketing, delivery, and paperwork. (Dunaway, 2000) Also, while diversifying products may add stability (not all the eggs in one basket), each new product will require more equipment, labor, storage space, production knowledge and skill, and outlets and time for marketing. Unless there is a large labor force available, too much diversification will be unsustainable. Dr. tatiana [sic] Stanton points out the following.

If you try to produce a whole line of products, it can make really big marketing demands on you if you are not going to sell them to the same buyer. For example, if you are a small producer and are going to sell fudge, soap, and cheese all to the same local food co-op or over the Web, that is one thing. You are going to have to do a lot more marketing if your

cheese is going to cheese shops or restaurants, and your fudge and soap to gift shops. You may find in such a case that it is a terrible decision to expand your line. (Stanton, 2002)

Brit and Fleming Pfann, owners of Celebrity Dairy in North Carolina, have said, "Marketing takes a huge amount of time, and as we've gotten more involved in cheese-making and in selling the cheese, we've found that we have very little time to spend with the animals." (Pfann, 2002) Other farmers have echoed that observation, and this is disappointing to those who enjoy the goats far more than processing or marketing. If you yourself do not want to be involved in marketing, then you will need a partner who is capable, reliable, and enthusiastic.

Your customers can be local individuals, restaurants, farmers' market patrons, grocery stores, or even mail-order and Web customers. Harvey Considine cautions against pricing products too cheaply.

In a competitive market such as goat cheese, one must be constantly aware of what the competition is charging, but even then everyone must know their own costs of production. If you do not cover those costs you will not be long in business. Keep in mind that other factors than competition can justify price... My counsel always is to produce a high-quality product consistently and charge what you must to make your venture profitable. (Considine, 1999)

There are successful farmstead cheesemakers, and their stories may inspire you. Their experiences should help prospective producers think through the demands of the occupation and decide whether family support and available labor will be adequate to meet the challenges. Some thoughts shared by Brit and Fleming Pfann, of Celebrity Dairy in North Carolina, [www.celebritydairy.com](http://www.celebritydairy.com), illustrate the demands of farmstead cheese making.

- Sustained long hours of work (all year)
- Great breadth of skills (dairy animals, cheesemaking, marketing)
- Significant capital investment
- ...and may return a modest annual income.





Another North Carolina goat dairy is the Goat Lady Dairy; like Celebrity Dairy, it produces delicious farmstead cheese and has other enterprises to diversify the farm income. Goat Lady Dairy also offers a class in farmstead cheese-making. To learn more about the dairy, visit [www.goatladydairy.com/](http://www.goatladydairy.com/).

For more information about processing your own dairy products, see the ATTRA publication *Value-added Dairy Options* and explore the Resources section of that publication as well as this one.

## Regulations

### Grade A Requirements

The U.S. Food and Drug Administration drafted the Pasteurized Milk Ordinance (PMO), which states that only pasteurized milk can be sold as Grade A. Enforcement of this ordinance

is under the jurisdiction of state departments of health or agriculture (Zeng and Escobar, 1995), and local requirements may vary. The American Dairy Goat Association Web site, [www.adga.org/](http://www.adga.org/), includes contact information for the authority in each state, and it is important to contact your state inspector early in the process of setting up your commercial goat dairy. The Web address for the contact information is [www.adga.org/StartDairy.htm](http://www.adga.org/StartDairy.htm). State inspectors will be able to make helpful suggestions and can assist you in planning and procuring USDA-approved equipment. Many producers have commented that their state inspectors helped them avoid expensive mistakes.

The Langston University publication *Grade A Dairy Goat Farm Requirements*— on the Web at [www.luresext.edu/goats/library/fact\\_sheets/d04.htm](http://www.luresext.edu/goats/library/fact_sheets/d04.htm)— discusses the requirements for a Grade A dairy. These include a milking barn or parlor

with a floor made of concrete or other impervious material for easy cleaning, and walls and dust-tight ceilings that are smooth, painted or finished, and in good repair. Sufficient ventilation is needed to eliminate condensation, minimize odor, and provide comfort for the milker. Adequate lighting is required, as well as a storage cabinet for medications. Wooden milking stands are not acceptable. (Zeng and Escobar, 1995)

A separate milk room is required for cooling and storing goat milk, to minimize the risk of contamination from the milking barn. The structure must be in good repair and easy to clean. The floor should slope evenly to a drain, and wash-sinks, hot water, and on-site toilets are required. Milking lines and other equipment should be of stainless steel or other smooth, non-absorbent material. Milk storage tanks must have an efficient cooling system. Fresh, warm milk coming out of

## Split Creek Farm, South Carolina

Evin J. Evans and Patricia Bell

Split Creek Farm, in Anderson, South Carolina, is a great example of a farm that started out small and grew to be a large operation. Evin Evans and Patricia Bell's goal was to be self-sufficient, and that required gradual growth.

Split Creek Farm started with three goats and a few acres. Over the years Evans and Bell added to their herd and their pastures, fences, and barns. The herd, mostly Nubians, peaked at 750 goats; the farm's goat population now averages approximately 275, with about half of those being milked.

Split Creek became a commercial Grade A Dairy in 1985 and started a small-scale cheese operation three years later. They increased their production as the demand for goat cheese grew, and by 1990 Split Creek had progressed from the original 4-gallon vat batches to the current 150-gallon vat batches. Split Creek currently sells raw milk, award-winning cheeses and fudge, soap, gift baskets, and folk art at a retail shop on the farm. Split Creek Farm's primary concerns are herd health and the ultimate quality of the dairy products they sell. In keeping with their commitment to sell natural products, Evans and Bell do not use hormones to enhance breeding or milk production, and herbicides and pesticides are not used on their pastures.

Evans and Bell, with assistance from two full-time and two part-time employees, care for the goats and produce and sell the products. They have worked long and hard for what they have accomplished, and they are proud of the quality of their goats and their goat milk products. For more information on Split Creek Farm, their products, and the crew behind it all, visit [www.splitcreek.com](http://www.splitcreek.com).

pipelines or milking buckets must be cooled to 45 degrees F within two hours. The water supply must comply with the Clean Water Act requirements, as enforced by the EPA, and a dairy waste management system must be in place. Grade A dairies are inspected at least twice a year, and milk samples are collected periodically.

## Scrapie Eradication Program

Scrapie is a fatal, degenerative disease affecting the central nervous system of sheep (and goats, very rarely), one of the class of diseases known as transmissible spongiform encephalopathies (TSEs). Other examples of TSEs include BSE in cattle and Chronic Wasting Disease (CWD) in deer and elk. There is no evidence that scrapie can spread to humans, but BSE, a TSE similar to scrapie, has been implicated in variant Jacob-Cruchfeld disease, and therefore there is a concern about its potential to spread to humans. Negative public perceptions and the loss of export opportunities have encouraged the efforts to eradicate scrapie from the U.S. The incidence of scrapie in goats is extremely low, so it is highly unlikely that your herd will be affected. Nevertheless, goat producers (and sheep producers) are required to participate in the Scrapie Eradication Program. Details about this program are available by contacting your state veterinarian or by going to the National Scrapie Education Initiative Web site, [www.eradicatescrapie.org/index.html](http://www.eradicatescrapie.org/index.html). You must first contact your state veterinarian to request a premises identification number. For additional information or for help in obtaining a premises ID number, call 866-USDA-TAG (toll-free). You will then receive free ear tags with your premises ID printed on them, and you must tag any breeding animals over the age of 18 months before they leave your farm. Dairy goat producers may use tattoos instead of ear tags, and the state veterinarian can assist by assigning a premises ID that consists of your state abbreviation and the ADGA tattoo sequence assigned to the farm. In addition, any breeding goat (or sheep) that crosses state lines (for shows or to be sold, for example) must be accompanied by an official Certificate of Veterinary Inspec-

tion (health certificate) issued by an accredited veterinarian. (National Institute for Animal Agriculture, [www.eradicatescrapie.org/index.html](http://www.eradicatescrapie.org/index.html)) Registered goats may be transported across state lines using registration tattoos as identification, provided they are accompanied by their negative certificate registration or a health certificate listing the tattoo number.

## Raw Milk Sales

Many natural foods consumers want raw milk. Many experts do not consider selling raw goat milk an option at all, due to legal issues and health concerns. Attorney Neil Hamilton discusses raw milk sales in his book *The Legal Guide for Direct Farm Marketing* (see **Resources: Books**). Hamilton recommends contacting your state department of agriculture for information on regulations.

*Get the advice of your state department of health before you agree to sell raw milk to individuals.*



photo by Charlie Rahm, USDA NRCS

The sale of unpasteurized milk is the subject of regulation because of concerns over the transmission of diseases. In some states, such as Iowa, the sale of raw milk—even in small quantities—is strictly prohibited by state regulation and the state officials take a rather rigorous approach on the issue. In other states, officials have a more permissive attitude toward the sale of raw milk, allowing small-scale personal sales to occur even if not specifically allowed by law. In some states dairy farmers are allowed to make limited sales of raw milk directly to consumers as long as the sales meet the requirements established by law

or regulation. The requirements usually relate to how the milk is sold, the quantity involved and compliance with state sanitation requirements for the dairy operation. (Hamilton, 1999)

Even if raw milk sales are legal in your state, you will want to consider carefully the risks of selling raw milk to customers. Many serious diseases can be transmitted to humans who drink raw milk, including brucellosis, tuberculosis, caseous lymphadenitis, leptospirosis, Q Fever, staphylococcal food poisoning, and others. (Smith, 1994) Even if you are sure your milk is pure, that the goats are healthy, that the milk has been handled with faultless cleanliness and carefully cooled, and even if you regularly drink the milk with no ill effects, once the milk

leaves your farm it may be carelessly handled and become unsafe to drink. This is especially hazardous if the person drinking the milk has a weakened immune system or is very old or very young. Get the advice of your state department of health before you agree to sell raw milk to individuals.

## Budgeting

Before beginning a commercial goat dairy, you must study the economic feasibility of the enterprise. There are many sample budgets available, but each must be customized to fit an individual farm. Investigate feed costs in your area as well as the selling price of milk. Costs of building or converting barns, fences, and watering systems are key considerations. Initial investment in livestock and in milking systems will be a large expense. Commercial dairy producers Stephen and Beverly Phillips of Port Madison Farm near Seattle, Washington, offer the following insights based on their experience.

“It takes capital to expand into a commercial-sized dairy,” Stephen says. “You must have the money to grow or keep the off-farm job or both. Sweat equity alone cannot do the job.

“A good plan, written down, is important to measure your progress. Otherwise, you get so close to the proverbial trees that you do not realize that you have made progress.

“When making improvements, it is important to plan for the size you may need in four or five years.

“And like most goat dairies, you need to beware of burnout.”

Beverly sums up her advice by emphasizing, “Don’t quit your day job too soon.” (Thompson, 1997)

Bee Tolman, operator of the Tolman Sheep Dairy Farm, offered further advice to prospective dairy farmers at the 2002 8th Great Lakes Dairy Sheep Symposium.

Do a complete business plan before you do anything else. Include all financial statements in detail. Don’t miss the details—they will be your undoing. And be conservative. I was advised by a goat dairy farmer (who has since folded) to add 30% to all budgeted costs. I didn’t. I now know that if I had, my plan would have been far more accurate. (Tolman, 2002)

As Ms. Tolman points out, it is wise to talk

to farmers who are currently in the business to ensure that your plan and your budget are realistic.

Begin your calculations by taking the following steps.

- Do *market research*. Is there a market? What is the current price for your product, whether fluid milk for processing, bottled milk, milk-fed livestock, cheese, or soap? Is there a strong demand for your product?
- Estimate *production level*. How many does are you planning to milk? How productive will they be, on average? (Does in a large herd typically produce less than does in a hobby herd; ask several commercial producers what their herd average is, and be sure to select does for your herd that can produce enough milk to be profitable.) Be as realistic about production and marketing as you possibly can.
- Investigate *costs*. What does feed cost in your area? How much feed will you need in order to produce the amount of milk you plan to produce and sell? What about buildings, equipment, fencing, hay? You will need to come up with marketing and hauling costs, health costs, costs of utilities, supplies, breeding, and labor. Initial cost of breeding stock, cost of raising replacements, and an extra “cushion” for unexpected expenses must also be considered. Remember that under-capitalization can doom even a good business venture.
- Consider *labor* NEEDED and available. Plan for peak seasons such as kidding and breeding, as well as any labor needed for processing and marketing.
- Compile a *business plan*. Your lending agency will tell you what other figures are needed; your local Cooperative Extension agent may be helpful. See also the **Resources** section for help with business plans.

Table 1 illustrates how production levels and price influence your profits. These numbers are based on Roger Sahs’ goat dairy budget, which is included in this publication.

The Minnesota Extension Service published a

very interesting look at the economics of the dairy goat business in 1989. Robert D. Appleman, the author, explored costs and returns from a 10-doe hobby dairy and a 100-doe commercial dairy. His budget (Economics of the Dairy Goat Business – HG-80-3606) can be ordered by contacting [order@dc.mes.umn.edu](mailto:order@dc.mes.umn.edu). He also did some fascinating calculations, such as looking at the impact of a change in cost of one input on the cost of producing 100 pounds of milk, the influence of marketing registered kids, or of marketing kid bucks, the labor required, and several other interesting scenarios. It is well worth reading the full article, and figuring today's costs for your area instead of Minnesota's 1989 costs. Even though the article is out of date, Appleman's conclusions offer food for thought, and are summarized below.

1. The cost of producing 100 pounds of goat's milk may vary from \$22 to more than \$37. To return a profit, then, a gallon of milk may have to sell for \$3.20 or more.
2. The greatest contributor to the high cost of producing goat's milk is labor. Every effort should be made to minimize this input. The greatest opportunity to accomplish this is to mechanize the milking process.

3. Marketing costs can be prohibitive.
4. Unless one has a good market for excess, it is not advisable to keep young stock beyond that needed to maintain the doe herd productivity.
5. If milk can be sold at a price of \$12/cwt or more, milk-fed kids sold at 25 pounds for 80 cents per pound are not profitable.
6. There is an economy to size, especially when combined with considerable sale of breeding stock.
7. Emphasize high production per doe. Maintaining dry does (non-breeding does that will have a long dry-period) can quickly eliminate any profit potential. (Appleman, 1989)

Oklahoma State University Extension Specialist Roger Sahs works on goat farm budgets for dairy goat and meat goat enterprises (see attached budget-Table 2). He recommends that farm managers take the time to work out an enterprise budget.

...[an enterprise budget] would be an essential tool in evaluating whether such an alternative would be to the manager's financial advantage. Farm management skills and knowledge are a very integral aspect of success with commercial

*continued on page 10*

**Table 1. Sensitivity of Milk Production versus Price on Per Head Net Returns above Total Operating Costs for a 100 Head Commercial Dairy Goat Herd. \***

Milk Prod. (lbs.)		-10% \$21.60	-5% \$22.80	Expected Price/cwt. \$24.00	+5% \$25.20	+10% \$26.40
-20%	1600	\$42.48	\$61.68	\$80.88	\$100.08	\$119.28
-10%	1800	\$85.68	\$107.28	\$128.88	\$150.48	\$172.08
Expected	2000	\$128.88	\$152.88	\$176.88	\$200.88	\$224.88
+10%	2200	\$172.08	\$198.48	\$224.88	\$251.28	\$277.68
+20%	2400	\$215.28	\$244.08	\$272.88	\$301.68	\$330.48

Break-even milk production above total operating costs is 1263 pounds/head at the \$24.00 price of milk.

Break-even milk price/cwt. above total operating costs is \$15.16 using a production of 2000 pounds/head.

\*Break-even price and production are calculated to cover total operating costs only while keeping revenues from kid and cull sales constant.

This table was developed using figures from the Dairy Goat Budget developed by the Department of Agricultural Economics, Oklahoma State University and included in the Economics section of this publication. (Sahs, 2003)

Table 2.

<b>Dairy Goats 100 Head Unit</b>						
<b>Class #2 Grade Herd, Per Doe Basis</b>						
<b>Operating Inputs</b>	<b>Units</b>	<b>Price</b>	<b>Quantity</b>	<b>Value</b>	<b>Your Value</b>	
Mixed Feed	CWT.	9.050	7.200	65.16	_____	
Alfalfa Hay	Tons	100.000	0.900	90.00	_____	
Vet Medicine	HD	10.000	1.000	10.00	_____	
Supplies	HD	12.000	1.000	12.00	_____	
Utilities	HD	18.000	1.000	18.00	_____	
Doe Repl. Feed	HD	32.800	1.000	32.80	_____	
Kid Feed	HD	22.000	1.000	22.00	_____	
Breeding Fees	HD	10.000	1.000	10.00	_____	
Misc. Expense	HD	6.000	1.000	6.00	_____	
Marketing Expense	HD	2.000	1.750	3.50	_____	
Machinery Labor	HR	7.500	0.847	6.35	_____	
Equipment Labor	HR	7.500	1.630	12.23	_____	
Livestock Labor	HR	7.500	7.692	57.69	_____	
Machinery Fuel, Lube, Repairs	DOL			5.32	_____	
Equipment Fuel, Lube, Repairs	DOL			12.57	_____	
<b>Total Operating Costs</b>				<b>363.62</b>	_____	
<b>Fixed Costs</b>		<b>Amount</b>	<b>Value</b>		<b>Your Value</b>	
Machinery						
Interest At	6.75%	11.80	0.80		_____	
Depr, Taxes, Insurance			2.38		_____	
Equipment						
Interest At	6.75%	209.71	14.16		_____	
Depr, Taxes, Insurance			26.31		_____	
Livestock						
Doe Goat		105.00			_____	
Buck Goat		5.25			_____	
Repl Doe-Goat		37.50			_____	
Interest At	6.75%	147.75	9.97		_____	
Depr, Taxes, Insurance			18.90		_____	
<b>Total Fixed Costs</b>				<b>72.52</b>	_____	
<b>Production</b>	<b>Units</b>	<b>Price</b>	<b>Quantity</b>	<b>Value</b>	<b>Your Value</b>	
Goat Milk	CWT.	24.00	20.00	480.00	_____	
Male Kids	HD.	20.00	0.90	18.00	_____	
Female Kids	HD.	50.00	0.65	32.50	_____	
Cull Doe Goats	HD.	50.00	0.20	10.00	_____	
<b>Total Receipts</b>				<b>540.50</b>	_____	
<b>Returns Above Total Operating Cost</b>				<b>176.88</b>	_____	
<b>Returns Above All Specified Costs</b>				<b>104.36</b>	_____	

5% Doe Death Loss, 200% Kid Crop

10% Kid Death Loss, 25% Doe Repl Rate

(Sahs, 2003)

Developed and processed by Department of Agricultural Economics, Oklahoma State University

continued from page 8

dairies. The ability to bear losses from business risk, a large capital base, and well trained labor are also important considerations. (Sahs, 2003)

Spend time working on budgets before committing the capital to a commercial enterprise. Show your budget to a commercial producer to check whether your figures on costs, receipts, and expected production are realistic; then consider whether your expected return is sufficient compensation for your efforts. Doing your homework before taking the plunge will save you much heartache and expense. Several other sample budgets are included in this publication in the **Resources** section.

## Production Notes

### Selecting stock

Once you have figured out what products you will sell, have the business plan and budget figured out, and are sure there is enough qualified labor and available capital to sustain the business, you are in position to select goats for the dairy. All the preliminary work will help you to prioritize and budget the purchases of stock and equipment, and to have an idea of what type of goats you need. For instance, commercial producers of fluid milk will want animals that produce a lot of milk; depending on the milk buyer's priorities, butterfat and protein percentages may also be important. A cheese maker will be more interested in total protein yield. Those who plan to sell breeding stock will want to consider production records, conformation, and pedigree (including records of related animals). Those who are marketing milk through kids may prefer a dual-purpose animal, such as the Nubian, that will bear meatier kids. A person purchasing a family milker will want

to milk the doe to see how easily she milks out, taste the milk for flavor, and observe her disposition. An animal that is perfect for one use may not be the best choice for another.

All buyers will need to find healthy goats that produce the quantity and quality of milk needed for their business. That is the essential part. However, many producers will first choose a breed that is personally appealing, then find breeders and visit farms to select goats for the dairy. Therefore, we will first discuss breeds, then address finding a breeder, evaluating health, and production records.

### Choosing a breed

Breed choice will depend on how you will use the milk, the availability of the breed in or near your area, and personal preference. Since there are differences in milk composition (% butterfat, % protein) and the quantity produced, some breeds will (on average) be more suitable for some farms than others. However, individuals WITHIN breeds vary more than individuals BETWEEN breeds. For instance, while on average, Saanens produce more milk than Nubians (see Table 3), some Nubians will produce more milk than some Saanens (as illustrated in the "range" column of the table). Though Nubians may produce less milk than Saanens, the composition of Nubian milk makes it more suitable for cheesemaking. Therefore, it is important to select individuals that possess the characteristics you need. Production records are the best way to know this. (Production records will be discussed later in this publication.)

Selecting a breed that is fairly common in your area may make it easier to acquire (and to sell) breeding stock, provided the other producers have goals and management systems similar to yours.



**Toggenburg**

Dept. of Animal Science, Oklahoma State University



**Nubian**

Dept. of Animal Science, Oklahoma State University



**Saanens**

Dept. of Animal Science, Oklahoma State University

## Oberhasli

Dept. of Animal Science, Oklahoma State University



Provided by Dave Battjes

## Alpines

Dept. of Animal Science,  
Oklahoma State University



Provided by Crystal D'Eon

## LaMancha

Dept. of Animal Science, Oklahoma State University



Provided by Karen Lee

© Oklahoma State University

Personal preference plays a major role in selecting a breed. Dairy farmers must spend hours with their animals, so get animals that you enjoy seeing, that will function on your farm, and that have dispositions that suit you. This is an individual choice, best made after observing individuals of various breeds and working with them, if possible. General descriptions of the breeds are given below. Further information about the breeds and contacts for the breed clubs are available from the ADGA Web site, [www.adga.org](http://www.adga.org). Descriptions and pictures of the breeds may be found on the Oklahoma State University Web site at [www.ansi.okstate.edu/breeds/goats/](http://www.ansi.okstate.edu/breeds/goats/).

In the United States, there are six full-size dairy breeds available. They are Saanen, Alpine, Toggenburg, and Oberhasli—the Swiss breeds—and Nubian and LaMancha.

Some producers raise crosses of these breeds; these crosses are referred to as “experimentals.” The Swiss breeds have similar body and ear shapes and similar milk composition.

Saanens tend to be larger than the other Swiss breeds, and are generally heavy milkers with slightly lower butterfat percentages. They are white goats with erect ears and are known for being gentle and productive milkers with long lactations. Saanens are sometimes called “the Holsteins of goats.” Saanens may sunburn and must have some shade available during hot weather.

Toggenburgs are recognized by their color pattern, since they are always brown with white legs, white stripes down the side of the face, and other white markings. They are medium sized, sturdy, and hardy. On average, their milk is lower in butterfat and in protein percentages than the other breeds.

Alpines come in a whole range of colors and color patterns and are slightly smaller

than Saanens. Like the Saanens and Toggenburgs, the Alpines originated in the cool climate of the Swiss Alps. Alpines are popular in commercial herds, and there are more Alpines on production test than any other breed (as of 2002).

The Oberhasli is a Swiss dairy goat of medium size. Its color is chamoisee (bay, with deep-red bay preferred, accented with black markings). Oberhaslis are not as numerous in the United States as the other breeds, and fewer Oberhaslis are enrolled in DHI production testing. Therefore, it may be difficult to locate stock, especially production-tested stock.

Nubians are known for their floppy ears and for producing milk that is highest in butterfat. They do not produce as much milk as the other breeds, and are considered a dual-purpose goat since they tend to be meatier than other breeds. Nubians are sometimes referred to as the “Jerseys of the goat world” and are the most common breed in the United States. Some producers think they are not well suited to a commercial dairy because of their active and energetic disposition. Others appreciate the Nubian’s contribution to the bulk tank, especially if the milk is intended for cheese, yogurt, or ice cream.

LaManchas were developed in the United States, and these goats are also easily identified by their distinctive ears. LaManchas have very tiny ears, and sometimes appear to have no outer ear at all. LaManchas are smaller than the other dairy breeds, but they are very good producers of sweet, creamy milk. Breeders of LaManchas claim that these goats are docile and sweet-tempered. They can be any color.

## Visiting a breeder

Visiting other producers can help you select a breed or breeds. Locating a good breeder is key to getting your business off to a good start. To find breeders in your area, you can check with your local Extension service. The American Dairy Goat Association (ADGA, [www.adga.org](http://www.adga.org)) publishes a directory of breeders every year, including contact information and a list of breeds raised by each member. It is well-organized and is free to members (\$35.00 annual dues).

You may want to visit three or four breeders before making a purchase; this gives you the opportunity to compare how the animals are raised, fed, and housed, and to assess the overall health of the herd. Ask lots of questions (see the section below for some suggested questions).

You should try to find a breeder who

- Is willing to provide health certificates
- Is part of the Dairy Herd Improvement Association (DHIA)
- Allows free access to all production and breeding records
- Manages a farm that has well-cared for animals and land

## Evaluating health

ALL buyers of dairy goats should insist on healthy goats. There are three main ways to gather information about the health of a dairy goat.

1. visual appraisal
2. interview the owner or herd veterinarian
3. request that certain tests be performed, such as
  - a. mastitis test (by milk culture or California Mastitis Test)
  - b. blood tests to check for CAE, TB, brucellosis, etc
  - c. fecal tests to screen for internal parasites

Ideally, all three methods (visual, interview, and testing) should be used.

First, examine the whole herd, looking for

- Shiny coats
- Lively manner
- Easy movement (no limping,

no swollen joints or misshapen udders)

- No abscesses
- Proper body condition (not fat or excessively thin)
- Firm, pelleted manure
- Well-shaped udders and teats (symmetrical udders)

A herd that meets all these visual criteria gives evidence of being healthy and well-managed.

Second, interview the herd owner or veterinarian.

- What diseases have been problems in this herd?
- What criteria do you use for selection or culling?
- What diseases are tested for routinely?
- What is the vaccination and parasite management protocol?
- Are replacement kids raised using pasteurized milk, to reduce the incidence of milk-borne diseases such as CAE, Johne's, mycoplasma, and others?
- How long do does stay productive in this herd?
- How long is the average lactation in this herd?
- What is the average production level of this herd? (Ask to see records.)

Third, ask that tests be run on the does you are considering. These tests will increase the



*Visual appraisal is one way to evaluate health.*



Table 3.

ADGA BREED AVERAGES-2002 LACTATIONS								
DOES 275-305 DAYS IN MILK	Number of Does	AVE. AGE at START of LACTATION	MILK lbs	RANGE	BUTTERFAT %	lbs	PROTEIN %	lbs
ALPINE	699	3y2m	2254	840-5300	3.5	78	2.9	64
LAMANCHA	216	3y3m	2097	1050-3510	3.9	81	3.1	65
NUBIAN	445	2y11m	1746	640-3670	4.8	84	3.7	65
OBERHASLI	68	2y11m	2062	990-3629	3.7	76	2.9	61
SAANEN	432	2y6m	2468	970-5630	3.4	84	2.9	71
TOGGENBURG	184	3y5m	2015	860-4480	3.2	64	2.7	55

Based on 2002 ADGA DHIR Individual Doe Records

Averages compiled by the ADGA Production Testing Committee

cost of the animal, and you should be prepared to absorb at least some of that cost. Some tests may not be necessary; if the veterinarian certifies that there are no suspected cases of Johnes, for instance, and you observe that all animals appear healthy, you may choose to forgo the Johnes test. Check with your veterinarian about which diseases are occurring in your area, and get his or her recommendations on which diseases are worth testing for.

Buying healthy stock initially will save you much money, time, and disappointment in the long run. Diseases shorten the productive life of the animal and reduce the chances of a profitable farm; therefore, it is wise to spend effort and money in the beginning to secure healthy animals. See the **Health** section of this publication and of the ATTRA publication *Goats: Sustainable Production Overview* for more information about some diseases to be aware of.

### Production records

Having verified that the stock is healthy, the next concern is their productivity. Keeping your needs (that is, the needs of your dairy products customers) in mind, investigate the productive potential of each animal. Production records from the Dairy Herd Improvement Association (DHIA) of the individual and of its relatives offer the best insurance that you are purchasing a pro-

ductive animal. Type classification, also known as linear appraisal (an objective score given by a trained judge, who provides a professional appraisal of an animal's conformation), may be available and offers another tool for selecting animals with desirable traits. Pedigree records are also very useful, since they give information about the genetic makeup of the animal. For a complete description of these tools and how to use them, as well as a wealth of information about what to look for in a good dairy goat, see *Dairy Goat Judging Techniques*, by Harvey Considine. This book can be ordered from [www.dairygoat-journal.com/bookstore.html](http://www.dairygoat-journal.com/bookstore.html) for \$16.95.

When examining production records, keep in mind that production is naturally much lower during the first lactation. Examine the records to see overall production in pounds, length of lactation, and butterfat and protein percentages (if those are important to your operation). Bear in mind that your own management will be a major factor in the doe's production on your farm; production records only verify that a goat has the genetic potential to produce milk. To learn more about production records, type evaluation (linear appraisal), and the DHI program, visit the American Dairy Goat Association (ADGA) Web site, [www.adga.org](http://www.adga.org).

DHI records are useful when purchasing goats, but are even more useful as a management

## Redwood Hill Farm, California

Jennifer Bice

(The following was adapted from an article by Jennifer Bice in the *Dairy Goat Journal*, September/October 2003. Ms. Bice is the owner of Redwood Hill Farm. The complete article, including a diary kept by Redwood Hill's farm manager, can be found on page 57-60 of that issue.)

Redwood Hill Farm Grade A Goat Dairy is located in Sebastopol, Sonoma County, California. Sebastopol is near the coast, about 50 miles north of San Francisco. Redwood Hill Farm is a "farmstead operation" because in addition to producing a unique line of artisanal goat-milk cheeses and goat-milk yogurt in five flavors, the farm manages its own herd of 400 dairy goats (Alpine, LaMancha, Nubian and Saanen).

The farm was started in the 1960s by Kenneth and Cynthia Bice and their 10 children. Active in 4-H with many different animal species, the family quickly made dairy goats their favorites. Jennifer Bice and her husband, Steven Schack, took over the family farm in 1978 and expanded the business and product line. Steven died in 1999, and Jennifer knew that continuing the business would be the best way to honor his memory.

With a herd of 400 registered dairy goats, a Grade A dairy, and a processing plant,

Redwood Hill Farm employs 12 people, as well as 5 work exchange students from other countries. These students stay for 12 to 18 months. They come from agricultural college programs in their own countries to live, work, and learn in the United States. While

the students don't always have direct dairy goat experience, they learn quickly and are highly motivated. Currently Redwood Hill Farm has students from Bulgaria, Hungary, Turkey, Honduras, and France.

Redwood Hill Farm is now building a larger processing plant to meet the demand for its goat milk products.

From award-winning animals (including ADGA National Champions in four breeds) to gold medal awards for their cheese and yogurt at product competitions, Redwood Hill Farm strives to be the best. That, along with providing a good life for its employees and the dairy goats themselves, is a big part of the Redwood Hill Farm mission.

*This story was written for the introduction to the Commercial Dairy Diary feature in the Dairy Goat Journal, September/October 2003. For a copy of this article/issue or other issues, please go to [www.dairygoatjournal.com](http://www.dairygoatjournal.com) or call 1-800-551-5691. For more on Redwood Hill Farm, see their Web site at [www.redwoodhill.com](http://www.redwoodhill.com).*



tool after purchase. In some areas, the cost is as low as \$2.00/month/goat. From the information you can

- Measure real productivity
- Track persistency through the lactation
- Evaluate the effect of a feed change
- Select your best producers and cull the lowest ones
- Identify potential mastitis problems
- Improve the profitability of your herd

Producers who are on DHI test say that it costs nothing, because it returns such valuable information that it more than pays for itself. Eliminating unproductive individuals will improve the sustainability of your farm; records are the best tool in this effort. For more information about production testing and to locate a DHI in your area, talk to local producers, contact your local Extension agent, or visit the Animal Improvement Programs Laboratory (AIPL) Web site at [www.aipl.arsusda.gov/](http://www.aipl.arsusda.gov/). (The AIPL site

contains production, type, and pedigree records compiled by ADGA and DHI, as well as other information.) The American Dairy Goat Association ([www.adga.org](http://www.adga.org)) also provides information about production testing and type evaluation.

Finally, when selecting stock, keep in mind that the most important part of the herd is the buck. As the sire of your next generation, the buck is “half of your herd,” and choosing an excellent buck is the quickest way to improve the herd. Again, production records (on the dam, daughters, and on any other relatives) are the best way to assess the usefulness of the buck. Linear appraisal will also be helpful, if available. The sire you select should come from good bloodlines and be healthy and fertile. Your veterinarian can perform a breeding soundness evaluation before purchase. If that option is not available, at least check the scrotal circumference of the prospective sire (it should be at least 20 cm.), to get an indication of sperm-producing potential. It is not a guarantee of fertility, however. Please refer to *Goats: Sustainable Production Overview* for more details on selecting a buck and evaluating breeding stock.

Choosing healthy stock with good genetics is an important step in setting up a sustainable farm. However, in order to live up to their potential, the animals must be well managed and correctly fed. In order to make a profit with dairy goats, this must be accomplished economically.

## Feeding

To review the information contained in the *Overview*, goats are ruminants, and their health and productivity depend on the rumen function. Microorganisms in the rumen digest fiber, carbohydrates, and protein and supply the animal with nutrients. Without those microorganisms, the goat will die. Therefore, it is of paramount importance that the animal is fed appropriately to keep the ruminal organisms healthy.

The rumen microorganisms are “healthiest” when goats are eating good-quality forages, such as vegetative pasture. To get the best milk production from your goats, you must provide excellent quality forages. A pasture that contains

many kinds of plants, including browse plants such as blackberries, multiflora roses, willows, or Russian olive, is ideal. Cool-season annuals such as ryegrass will provide a lush, high protein forage in the early spring before many other grasses are tall enough to graze. In the winter, a good mixed-grass hay (cut at an early stage of maturity) is ideal. Goats will eat a wide variety of plants, including weeds. They are selective eaters that will seek the most nutritious plants while grazing, browsing, or eating hay. They are also wasteful eaters, and therefore it is wise to help them use their feed more efficiently by controlling their grazing and by feeding them only a little more hay than they will clean up. There is a trade-off here; if you allow goats to be very selective, they will waste more feed, but they will produce more milk. If you are too strict with their



forage allowance, you will save money on feed but lose income from milk. Experience and experimentation with your own herd and farm will help you find that happy medium. For more information about pastures and rotational grazing, see the ATTRA publications *Sustainable Pasture Management*, *Rotational Grazing*, *Introduction to Paddock Design*, and *Matching Livestock Needs and Forage Resources*. Also check with your local Extension and NRCS agents for information about what forage plants do well in your area. Information about the grazing habits of goats is provided in the ATTRA publication

*Goats: Sustainable Production Overview*. Some studies about pastures for dairy goats are discussed below.

Steve Hart and B. R. Min at Langston University are doing research on grazing-based dairy goat production systems (see **Resources: Contacts**). Dr. Hart points out that the “goal of pasture management is to supply high quality pasture starting at the beginning of lactation and maintain high quality forage in sufficient quantities throughout lactation.” This is very difficult and requires the establishment of several types of forage. At Langston (in Oklahoma), they grazed cool season annuals such as wheat, rye, or oats, perennials such as orchardgrass, Berseem clover interseeded with wheat, and warm season grasses

such as crabgrass, sudangrass, millet, Johnson-grass, and cowpeas. While it is important to have an assortment of forages available, it is also crucial to maintain those forages in a vegetative state, because that is when their protein levels and digestibility are highest.

At the same time, it is very important to control grazing so goats do not graze too close to the ground, since that will hurt the plants' ability to regrow and will expose the animals to more parasite larvae. Removing goats from the pasture when they have grazed the grasses down to about 3 to 4" will greatly reduce parasite problems. Another practice that will help is to graze cattle after the goats to pick up larvae and "clean" the pasture. Tilling or making hay after grazing will also help. More information about internal parasites is provided in the ATTRA publication *Integrated Parasite Management for Livestock*.

In 2001, producers Kristan Doolan and George van Vlaanderen of Does' Leap Farm in Vermont conducted a Northeast SARE project comparing the production of dairy goats that either grazed pasture or browsed in a wooded area (see **Resources**: SARE Project Producers). In that experiment, the goats that browsed produced more milk and had longer lactations. The investigators concluded that browse is at least as nutritious as pasture, and that the shade in the browse areas helped keep the does cooler, which also helped production. The full article was published in *The Dairy Ruminant Newsletter* and then re-printed in *CreamLine*, Winter 2002 issue.

Darrell Baker also used SARE funding to explore the potential for using irrigated pasture at his dairy in Tucumcari, New Mexico. Over a two-year period, Mr. Baker made observations and kept financial and production records. He concluded that irrigated pasture provided a very environmentally friendly way to produce milk, and that dairy goats were a profitable way to use irrigated pasture. His observations are of interest, and we offer the following excerpt from his final report.

...I also noticed that the goats have an incredible sensitivity to pasture quality. I was expecting this to some degree, but not to the degree that



**Goats will eat a wide variety of plants**



it showed up. Because I could measure milk production on a daily basis, the sensitivity was much more noticeable with the goats than if I had been running steers... There was also a noticeable correlation between paddock moves, length of stay, and milk production. During the first three days in a fresh paddock, milk production

would rise then fall during the next three days from 5 to 10 percent. Another move to a fresh paddock would cause a 2 to 11 percent rise, then as the stay lengthened, milk production would start dropping again even though there was still a large amount of forage left in the paddock. This leads me to believe that I need more and smaller paddocks, more moves, and more goats to fully utilize the forage available while keeping pasture production up. (Baker, 1998)

As mentioned previously, Drs. Hart and Min at Langston University have been conducting research on grazing dairy goats. As part of this work, goats were fed four different rations:

- A – Control: Kept in the barn, fed alfalfa hay and a high level of grain (2/3 lb. of grain for every pound of milk over 3.3 lbs.).
- B – Grazed and fed 2/3 lb. of grain for every pound of milk over 3.3 lbs.
- C – Grazed and fed 1/3 lb. of grain for every pound of milk over 3.3 lbs.
- D – Grazed, no supplemental grain.

Researchers found that body condition of the does greatly influenced milk production, with thinner does being less productive during the lactation. Internal parasite problems also had a negative effect on production. Milk production responded to grain, increasing by 1.7 pounds for every added pound of supplemental feed. However, in the second year of the study, when

the does were kidded in better body condition, does fed no supplemental grain produced 7.74 lb. milk/day, while those in the barn produced 8.91 lb/day, and the does fed a small amount of grain (1/3 lb. for each pound of milk over 3.3 lb/day) produced 9.17 lb/day.

Considering the cost of grain and alfalfa hay, it seems likely that the goats on pasture were much more economical to feed and produced comparable quantities of milk. This has implications for those considering organic dairies and for others who want to reduce feed costs. Hart notes that butterfat percentages were lower in the second year for goats that were not supplemented. He also notes that having high-quality forage available in adequate amounts is the key to feeding dairy goats on pasture. The full description of this research is available on-line at [www2.luresext.edu/goats/library/field/hart02.html](http://www2.luresext.edu/goats/library/field/hart02.html).

As stated earlier, rumen microorganisms are “healthiest” and milk production is highest when goats are eating high-quality forage. However, it is difficult (if not impossible) to provide good-quality pasture year round. Also, dairy goats have a high requirement for nutrients because they are producing milk at a high level. Therefore, supplementation with concentrates will usually be necessary.

Care is needed when feeding concentrates (grain) to balance the energy needs of the goat and to protect the ruminal organisms. With this in mind, there are some general rules for feeding dairy goats.

1. Graze goats on the highest-quality forage available, and be sure there is a plentiful supply of good pasture or good-quality hay.
2. Lactating dairy goats need about 5 pounds of feed per day (dry matter basis) per 100 pounds of goat, with at least half of this being forage. Some goats will eat even more during peak lactation (up to 6% of body weight on a dry matter basis).
3. Goats require 12 to 14% protein in their diets (the higher amount is for growing kids or high-producing does).
4. Limit the feeding of grains so that the pH of the rumen stays in a favorable range.
5. Increase grain levels very slowly (.2 lb every 3 or 4 days, to a maximum of no

more than 50% of the diet).(Hart, 2004)

6. Feed cracked rather than ground grains to encourage rumination and thus salivation, which helps to buffer rumen acids and maintain favorable rumen pH.
7. If you must feed high-concentrate diets (for example, to an extremely high-producing doe during peak lactation), divide grain into several small feedings and offer sodium bicarbonate to help buffer the rumen.
8. If diets are not high enough in roughage, it may be necessary to feed a buffer (such as sodium bicarbonate) at 4% of the concentrate ration in order to maintain butterfat production.(Smith, 1994)
9. It is always important to monitor the feed consumption of your herd. If they are not cleaning up their grain, grain should be reduced and better quality forage offered.

Because of the lactation curve, individual requirements change over the course of the year.

#### Guidelines for supplementing lactating does

- Start the doe on grain a month before kidding and have her consuming about 1.5 lbs of grain by the time she kids. This allows the rumen organisms to slowly adapt.
- After kidding, increase grain slowly to about 3 lbs/day by 4 weeks post-kidding.
- After peak lactation, feed according to milk production. Feed 1/2 lb of grain for every pound of milk over 3 lbs milk/day, along with good quality forage. For example, a goat producing 8 pounds a day would get all the good forage she could eat plus 2 ½ pounds of grain, split into two feedings (5 lb. milk over 3 lb. x ½ lb feed/lb milk).
- Never feed more than 4 pounds of grain to a doe per day. (Hart, 2004, and Smith, 1994)

Producers generally adjust the amount of supplementary feed, rather than change the ration composition. Care must be taken to avoid sudden changes in diet, and careful observation is needed to monitor body condition and milk production so that supplementary feed may be increased or decreased when necessary. Over-feeding is wasteful and counter-productive, as it may result in does that are too fat, have birthing problems, and do not milk well. On the other hand, under-feeding in late gestation will place the doe at risk for metabolic diseases (pregnancy toxemia) and may also reduce production through the lactation period. The safest bet seems to be to allow the pregnant doe plenty of good-quality forage – and be sure the doe is indeed eating plenty of it. Allow 4 pounds of forage (dry matter basis) per 100 pounds live weight of the doe.

Does that consume a lot of forage during late pregnancy will continue to eat ample forage after kidding, will be less susceptible to digestive disorders, and will yield more milk at the same concentrate level. One French study looked at the effects of the ration during late pregnancy and early lactation. One group of Alpine goats was fed a well-balanced diet, including alfalfa hay (as much as they wanted) and a limited amount of grain during late pregnancy, with a slow increase in grain during early lactation. Another group was fed a restricted amount of hay, a large quantity of grain during late pregnancy, and a quickly increasing amount of grain after kidding. Each of the goats fed ample amounts of hay produced about 148 pounds more milk on average during the first 12 weeks of lactation than the goats fed a restricted amount of hay, a large quantity of grain during late pregnancy, and a fast increase

Here is a sample ration for lactating dairy goats that provides 15% protein and should be fed with good alfalfa hay.

Corn	100 lbs.
Oats	100 lbs.
Soybean meal, crumbles or pellets	50 lbs.
Dairy mineral	13 lbs.
Cane molasses	15 lbs.
Salt	3 lbs.
Total weight:	271 lbs.

(Considine, 1996)



in the amount of grain fed after kidding. (Morand-Fehr, 1978)

Hart's research at Langston University (see **Resources:** Contacts) has also been exploring the effect of level of grain supplementation on milk production. See the Langston Web site at [www.luresext.edu/goats/index.htm](http://www.luresext.edu/goats/index.htm) for more information.

While the focus of this section is on feeding lactating does, you should remember that the care and feeding of kids and replacement animals is equally important. Kids kept for replacements should be fed lots of good quality forage so that they can reach 75% of their mature body weight in about 8 months. Breeding does to freshen as yearlings will increase their lifetime production. To increase your understanding of the kid's digestive system and how to feed young animals, refer to [www.gov.on.ca/english/livestock/goat/facts/goatnutrition.htm](http://www.gov.on.ca/english/livestock/goat/facts/goatnutrition.htm), and [www.sheepandgoat.com/articles/artificial-feeding.html](http://www.sheepandgoat.com/articles/artificial-feeding.html). Another resource with information on kid rearing is the *Dairy Goat Production Guide*, by Harris and Springer, University of Florida. This guide includes a good general overview of raising dairy goats and is available on-line at <http://edis.ifas.ufl.edu/DS134>.

## Milking

Goat milk production is usually seasonal in the U.S., with most dairy goats being bred in the fall and kidding in the spring. However, year round production is required by some markets, and it is possible by staggering kidding. This is done by breeding does out of season, which requires extra management. Milk production will be less in the does producing out of season com-

pared to does freshening in the spring. Therefore, producers will need to get a premium milk price to offset the lower production in the off season.

Goats usually lactate for eight to ten months and produce about 750 quarts of milk during that time. (Considine, 1996) This is approximately 1500 pounds ("a pint's a pound," roughly, so a quart is two pounds) and is not sufficient production to sustain a viable commercial operation, according to Tatiana Stanton of Cornell University. (Stanton, 2003) She estimates a commercial fluid milk operation needs more than 2000 pounds of milk production per head in order to be profitable. Again, this reinforces the value of production records so that the profitable animals can be identified, while unproductive (and therefore unprofitable) goats can be culled.

Milking must be done on a routine schedule. Most farmers milk twice a day at 12 hour intervals. Milking can also be done three times a day. There will be an increase in milk yield, but often the increased yield is not worth the extra time and labor involved in milking three times a day. There has also been research on milking goats once a day. Milking once a day decreases milk yields, especially in early lactation. Milk from goats milked once a day contained higher percentages of total solids, yet total solid yield was less than does milked twice a day. (Salama, 2003)

You should milk young, healthy animals first, and oldest animals last. This decreases the spread of infections and disease. Calm, low-stress handling of the does at milking time will aid in reaching optimum milk production. You should strip the teats before milking to observe any abnormalities in the milk. Some of the abnormalities that may be seen are clots or little butter-like chunks in the milk or stringy milk. Both are evidence of mastitis. Each doe will take two minutes to milk out. (Mowlen, 1992) During milking time it is a good idea to inspect the does for any signs of injury or disease.

Hand milking is efficient for herds of up to a dozen or so goats. Many hand-milkers use a seamless, stainless steel pail with a hood or cover to keep out debris. Many producers find that milking is a good time to feed the doe grain. This keeps the doe occupied and standing still during milking. Using a milking stand provides several benefits. It keeps the doe tied and standing still and also puts the doe at a comfortable height for the milker. See the hand-milking sketch for an example of a milking stand (Illustration 1).

A platform can also be used when hand milking or when using a milking machine. The platform should be 15 to 18 inches high and constructed so each animal has adequate space to be tied. Allow 3½ feet in length for each doe and 18 inches in width. Does will mount the platform by steps or a ramp. It is vital that the ramp/steps be made so that the goats will not slip. Slipping just once can make does reluctant to go up to the platform.

For herds larger than 15 or 20 goats, it is often more economical and practical to machine milk. Milking machines for small-scale operations are available from Caprine Supply and Hoegger Supply Company, among others. Farms with more than 50 goats will require a large and efficient milking parlor, designed for convenience and in compliance with regulations. When herd size justifies a parlor, there are several designs to choose from. Milking can be done from the front, back, or side of the doe, and milk can go directly into the bulk tank or first go into recorder jars that let you monitor individual production.

Proper sanitation, proper vacuum levels, and proper milking machine maintenance will also reduce the risk of mastitis. Monitor your equipment to make sure that it is functioning properly. Fluctuation of the vacuum in the milking machine can cause backwash, which allows intramammary transmission of bacteria. Also, a doe with teats that are the wrong shape or size can cause vacuum problems. To minimize this risk, milk young, healthy udders first, and then milk abnormal does last.

Whatever the parlor design, it is crucial that your parlor is set up so animals move in and out quickly. If the parlor is set up inefficiently, milking time will increase dramatically. Visit several farms to see possible layouts and talk to current producers about the advantages and disadvantages of their designs. Because parlors will be used twice daily for many years and require a major financial investment, it is important that they be carefully planned.

Regardless of the milking set-up and method, you must maintain sanitary practices, from cleaning the teats before milking to handling the milk. Teat sanitation is probably the most critical step in milking. Milking time, milk quality, and risk of mastitis (see **Health** section) all depend on how teats are cleaned.

There are several different methods of cleaning the teats before milking. You can spray the

teats with water using a low-pressure nozzle. The water should be warm and may contain a sanitizer. The teats must then be dried, usually using paper towels. The problem with spraying is that too much water gets on the udder, and dirty water ends up on the teats and in the teatcups. This leads to contaminated milk and an increase in mastitis. For these reasons, spraying with a low-pressure nozzle is not recommended unless the teats are very dirty (which should not occur if sanitation is adequate). There are premoistened towels (similar to baby wipes) that are available

to clean the teats. These towels are easy to use and work well on teats that are not very dirty. The drawback to these towels is that they are expensive.

Predipping is another way to clean teats before milking. Most experts consider it the best sanitizing procedure to reduce mastitis. (Levesque, 2004) The whole teat should be covered with disinfectant (some producers use the same disinfectant for pre- and post-dipping, and others choose a less expensive predip) that is then left on the teat for 15 to 30 seconds. The teat is then wiped dry.

Illustration 1

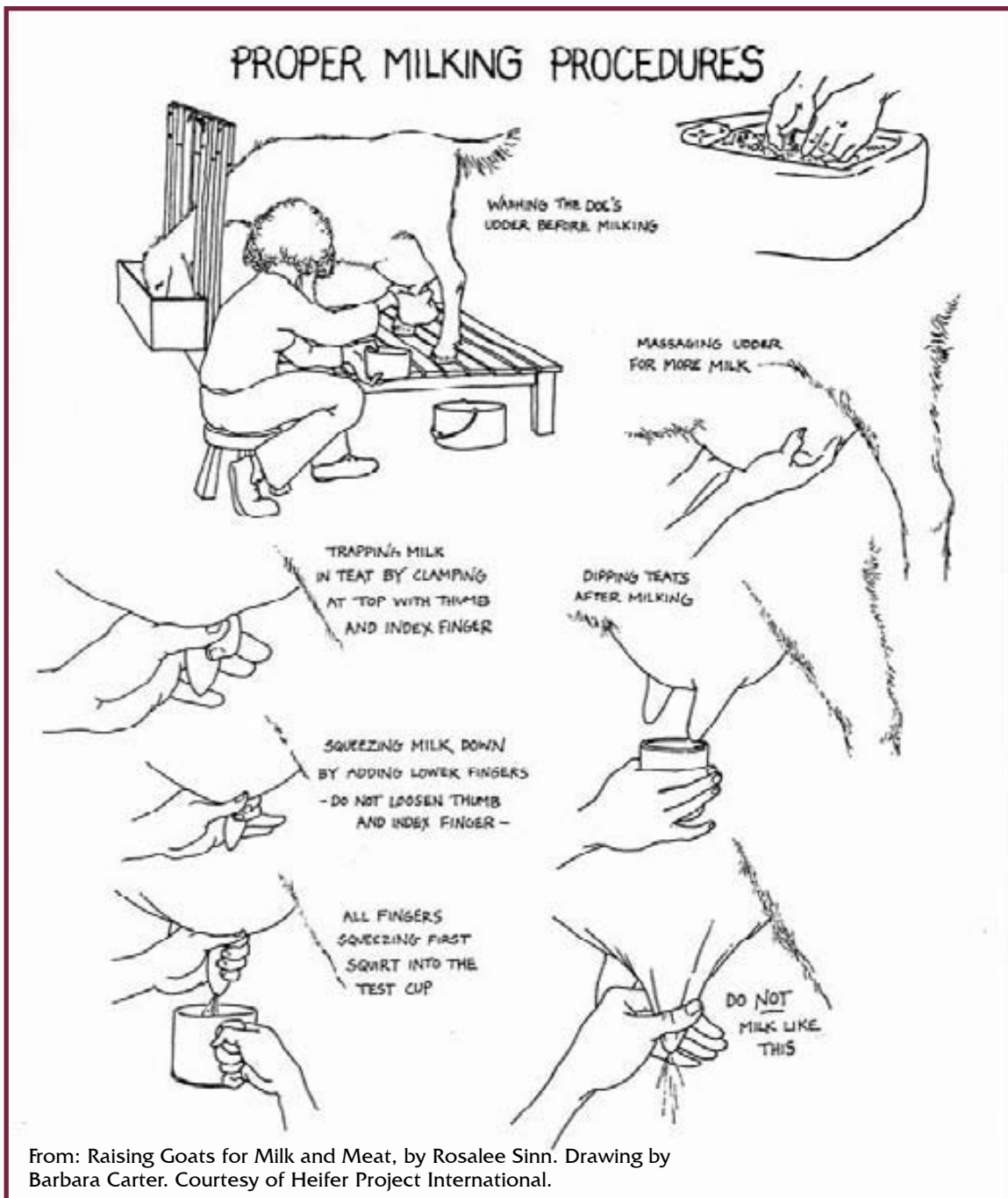



This is important for teat stimulation and to make sure all of the disinfectant is removed before milking. The teats can be dried with individual paper towels (never use the same towel on more than one doe) or cloth towels (individual as well). Cloth towels dry and stimulate better than paper towels and in the long run are cheaper. (Levesque, 2004) If using cloth towels, you must properly sanitize them between milkings, by using hot water and bleach and drying them in a clothes dryer.

Whatever method is used for cleaning the teats, it must be done thoroughly and consistently. You must also realize that no disinfectant will be efficient on very dirty teats. Some teats may have to be washed and then disinfected. Once you have the teat clean, disinfected, and dry, do not touch it again before milking or you will put bacteria back on it. After milking, the teats must be dipped in disinfectant called teat dip (usually iodine). The teat canal is relaxed and dilated after milking, which makes it more vulnerable to bacteria. That is why disinfecting after milking is crucial in preventing mastitis.

Sanitary practices must also be used when handling the milk. After milking, strain the milk with a disposable filter, and then cool the milk immediately. Ice-water baths work well for small scale operations. A bulk tank cooler is necessary for larger operations, and it must chill the milk to 45 degrees F within two hours.

All milking equipment must be thoroughly cleaned and sanitized after using. Milk residue must be removed, and all milk contact surfaces must be cleaned thoroughly to remove bacteria. Milk residue should be immediately rinsed out with warm (100-115° F) water. The utensils should be cleaned with soap and a scrub brush, immediately rinsed, and hung on a rack so that they are dry prior to the next milking. Utensils must be sanitized with a chlorine solution immediately prior to milking.

Strict sanitation is necessary to prevent diseases and is critical for food safety. It requires time

and money, but it is time and money well spent. It is cheaper to prevent disease and contamination than to treat it. A good reference for producers considering a commercial dairy is the *Small Ruminant Guidelines* from the Dairy Practices Council. These *Guidelines* include a wealth of technical information about the details of setting up a milking parlor, producing quality milk and farm-



**Farms with more than 50 goats will require a large and efficient milking parlor**

stead cheese, proper handling of wastewater, and much more. The *Guidelines* are sold separately or as a set; the set costs about \$70.00 plus shipping and handling and is assembled in a binder for easy storage and reference. For more about this resource, see [www.dairypc.org](http://www.dairypc.org), or call 732-203-1194. For a commercial dairy operation this is

an invaluable tool.

Does are bred to freshen once a year and are usually allowed a two to three month nonlactating (dry) period before the next parturition. This allows the mammary system time to repair and regenerate for the next lactation. The greater a doe's production, the longer the dry period should be, because she has used more nutrients than an average-producing doe. She will need more time to replenish losses and store reserves. Does that are not given a normal dry period usually produce only 65 to 75% as much milk in the subsequent lactation as does given a dry period. (Harris and Springer, 1996) It is important for does to be dried off in good body condition and have a minimum of an eight week dry period. When drying off a doe you should reduce the quantity and quality of her diet. Grain should be reduced or removed, and she should be given a lower quality of hay. Changing the doe's routine will assist in reducing milk flow. You must continue to monitor drying-off does, because it is common for mastitis to develop during this time.

## Health

The *Overview* contains information about health issues that are important for all goats, including internal parasites, Caprine arthritis

encephalitis, abortion, footrot, caseous lymphadenitis, contagious ecthyma, and fly control. This publication provides discussion about three additional diseases of particular interest to dairy goat producers: mastitis, Johne's disease, and ketosis.

## Mastitis

Mastitis is an inflammation of the mammary gland. It is usually caused by the bacterium *staphylococcus* or *streptococcus*, but it can also be caused by other bacteria, such as *mycoplasma*, *e. coli*, and *pseudomonas*, or by improper milking machine operation. Symptoms include pain, heat, redness, swelling, and a hard udder. Mastitis causes a reduction in production and in profitability. Does will not always show physical symptoms of mastitis. A decrease in milk production and an increase of somatic cell counts are good indicators of mastitis. Somatic cell counts rise in late lactation, so a rise in SCC is not always an indicator of infection. Milk samples can be cultured to determine the organism causing mastitis (*strep.*, *staph.*, or *mycoplasma*). *Mycoplasma* is cultured differently from *staph.* and *strep.*, so you must request the milk test for *mycoplasma*; it will not show up on the *staph/strep* test. *Streptococcus* infections are responsive to antibiotics and are fairly easy to eradicate. *Staphylococcus* infections do not respond well to antibiotic treatment. *Mycoplasma* is less common than *staph.* and *strep.*, but it is highly contagious and is usually the culprit in herds experiencing outbreaks of clinical mastitis that resist therapy. *Mycoplasma* can be transmitted to the kid through the milk. Raising kids on pasteurized milk will reduce the incidence of *mycoplasma* in the herd. Once a doe is infected with *mycoplasma*, she will be a lifelong carrier and will shed the organism in her milk and feces. There is no effective treatment for mycoplasmal mastitis, but it can be controlled. You must identify infected animals by culturing milk samples and then segregate or cull infected animals. The California Mastitis Test (CMT) is another tool for detecting mastitis. The CMT is cheap and easy, but is not very sensitive for goats. The CMT is more useful for ruling out mastitis than for diagnosing it in goats. (Smith, 1994)

Other causes of mastitis may include injury, malnutrition, or a contaminated or malfunctioning milking system. The first line of defense against mastitis is healthy teat skin. The cause of teat injury must be quickly identified and

eliminated. Mastitis is also linked to diets deficient in vitamins A and E, selenium, and copper. Fluctuations in the milking vacuum, improperly designed and improperly functioning milking equipment can also lead to mastitis.

## Johne's Disease

Johne's Disease is a contagious, chronic, usually fatal bacterial infection of the intestinal tract. This disease primarily occurs in ruminants,

### To implement a mastitis control program

1. Examine udders twice daily at milking for abnormal secretions of milk (e.g., lumps or stringy milk) and hot, swollen udders. Treat early if mastitis is detected.
2. Wash (with a minimum of water) and dry teats before milking. Remove the milking machine promptly when milk flow has ceased.
3. Use a recommended teat dip following each milking to decrease entry into the udder of mastitis-causing organisms.
4. Dry treat (infuse teat with antibiotics) at drying off to kill bacteria in the udder.
5. If milking by machine, have equipment checked periodically to be sure that it is functioning properly.
6. Employ strict sanitation practices so that mastitis is not spread from one goat to another, including using individual towels for cleaning the teats and disinfecting the milking machine after milking a goat with mastitis.
7. Treat all cases of mastitis promptly and properly with antibiotics. Record all treatments and note the withdrawal times for milk and slaughter. If re-treatment is necessary, use a different antibiotic, as bacteria vary in their resistance to different antibiotics. In problem cases, have your veterinarian culture a milk sample to determine the most effective treatment. (Pennington, no date)



***Paying attention to your animals and to selection, nutrition, and sanitation will increase the health and productivity of your herd.***

*Dr. Jean-Marie Luginbuhl, North Carolina State University*

with different serotypes of the bacteria infecting cattle and goats. Johne's can be difficult to detect because an animal can be infected for months and not show signs. Clinical cases of Johne's rarely occur before one year of age and are most commonly seen in two- and three-year old goats. (Smith, 1994) By the time a clinical case is detected in a herd, there will usually be several sub-clinical carriers of the disease (animals not showing signs). Carriers of the disease shed the bacteria, which can survive in the environment for more than a year.

Weight loss while maintaining a good appetite is the best indicator of Johne's Disease in goats. Cattle have diarrhea when infected, but this is not usually a clinical sign in infected goats. There is no known treatment for Johne's, but there are several tests that can be used to detect the disease. Many diagnostic labs offer ELISA and AGID tests to detect and confirm cases of Johne's. Fecal testing and tissue sampling can also be used to detect the disease. Johne's is not considered a major problem for goat producers, but it is a disease that can cause problems if introduced into a herd.

### **Ketosis**

Ketosis is a term for a metabolic condition whereby the animal cannot or will not consume enough energy to meet its needs. Goats are at risk for ketosis during late pregnancy (pregnancy toxemia) and during early lactation (lactational ketosis).

Pregnancy toxemia can be caused by either underfeeding or overfeeding in early pregnancy. For instance, a doe that is carrying more than one kid and is not fed enough energy will be ketotic. An over-fed doe will have less capacity to eat because the full uterus plus internal fat stores take up too much space, thus limiting the amount of feed the doe can hold. Also, feeding too much grain (or corn silage) in late pregnancy will cause the doe to develop acidosis; this puts the doe off feed and may contribute to pregnancy toxemia.

Similarly, rapidly increased energy demands during early lactation cause high-producing dairy goats to lose weight and condition, as they can not eat enough to meet their needs. A gradual increase in the amount of grain offered (.2 lb every 3 days) (Smith, 1994) will meet enough of the energy needs to protect against ketosis, but will not trigger acidosis.

Treatment of ketosis involves improving the diet by offering better quality roughage and slowly increasing concentrates. Propylene glycol is also given to increase blood sugar levels, but overdoses can be fatal; Mary Smith of Cornell University recommends 60 ml given two or three times daily. (Smith, 1994) In cases where the disease has progressed and the doe is unable to eat or to get up, consult your veterinarian. If the doe is within one week of her due date, inducing the doe to kid or performing a C-section may save either the kids or the doe.

Treatment of mild acidosis (when the doe is off feed because of over-eating grain) involves offering the best quality hay and withholding grain to allow the rumen to recover. Plenty of water, oral antacids, and oral tetracycline may help. Severe acidosis may kill the doe; the goat will be off feed, the rumen ceases to function, and the animal may groan, grind teeth, have constipation followed by diarrhea, and go down. This is a very serious condition; consult your veterinarian immediately if you suspect the goat has over-eaten grain.

Again, prevention is best; increase concentrates very slowly, and do not feed finely ground

grain (cracked is preferable). Protect the rumen organisms by feeding several small feedings rather than one large feeding, and offer forage first.(Smith, 1994) Steve Hart recommends that you start a doe on grain a month before kidding and gradually work up to 1.5 pounds of grain (in two feedings) by kidding time; then gradually increase (.2 lb. change every 3 or 4 days) until you are feeding .5 pounds of grain for every pound of milk over 3 lbs./day, always providing good quality forage or hay. Never feed more than 4 pounds of grain per day, and use cracked corn rather than ground to reduce the incidence of acidosis.(Hart, 2004)

See ATTRA's *Goats: Sustainable Production Overview* for information about other significant health problems, including CAE, CL, internal parasites, abortion, soremouth, and footrot. Further information about disease prevention and treatment can be found by consulting your veterinarian and by exploring the resources listed at the end of this publication.

Remember that for all diseases, prevention is

better than treatment. Paying attention to your animals and to selection, nutrition, and sanitation will increase the health and productivity of your herd.

## Conclusion

The decision to start a dairy goat operation is not easy. You probably will not become rich, but if you like goats, have the markets and an understanding of them, and have the time to build a business, this can be a rewarding enterprise.

There is much more to learn about dairy goat production, and the **Resources** section will help you to find more information. Your best source of information is another farmer; talk to as many as you can, and learn from their experience.

"Sustainability" is proven with time, and the following story illustrates some of the necessary ingredients for a sustainable dairy goat business. Our thanks to the author/farmer, Debbie Taylor, for sharing her story.



## Blufftop Farm, Arkansas

Debbie and Randy Taylor

*By Debbie Taylor, 2004*

Blufftop Farm is located in Pope County, Arkansas, in the foothills of the Ozark mountains. The soil is sandy and shallow. Most of our farm is used to grow timber of many species.

We (my husband Randy and I) began raising goats in 1974 as a hobby and for milk for ourselves. We began with a grade doe, a purebred Nubian doe, and a purebred Nubian buck. We had been married two years and lived on a farm owned by his family, who lived out of the state. I was a city slicker who had always wanted to live on a farm; he had a little farming experience, mostly with grain. The hobby persisted and grew, and gradually more breeds were added. We began showing the goats and went on DHIR test. Eventually there was too much milk, and commercial production was investigated.

Throughout this time we had a few jobs, Randy went to college, and our logging business evolved. We purchased our own land and built fences, barns, shops, and our house in 1985, the dairy in 1986. Though I do not work in the log woods anymore, I do the bookwork for our company. Randy does not help with the daily goat-related chores but helps fix everything that needs fixing and operates the hay baler. Our daughter, Jessica, helps with the goat operation. I was a licensed American Dairy Goat Association judge for 15 years, but it is too hard to do all that traveling and do a good job with the operations at home.

Currently, we milk 72 head. The milk is marketed to the only plant currently operating in our state (Jackson-Mitchell, Yellville, Arkansas). A tanker picks it up at the farm weekly. The milk is processed, evaporated, and canned.

We sell most of the doe kids and quite a

few of the bucks, mostly to other breeders who want goats for showing or family milk, and we export some goats. Having the herd on DHIR test, appraising them yearly, and showing some, has helped sales of kids. We like having registered stock, and though it requires a lot more planning and paperwork, kid sales are an important part of the income.

It was not difficult to get set up. In our state, a person contacts the Milk Program department of the Health Department and asks for a set of regulations. The person then designs a dairy and asks a rep from the Program to come out to view the plans and the site before construction begins. Before milk is shipped, the dairy has to be inspected and the water source tested. Although our milk is used for manufacturing, we built our dairy to be Grade A so that we can sell Grade A milk if we choose to. The difference in a Manufacturing Grade dairy and the Grade A dairy is not much. The dairy is inspected regularly. I like to visit with the inspectors, as they have a lot of good ideas and are helpful. The inspectors are the same ones that inspect the cow dairies and milk processing plants.

The scale of production needed to make a living is going to depend on the price received for the milk, and many other factors. The biggest challenge for us now is getting a better price for our product.

The venture has been very interesting to me; I enjoy the work and the animals. It has not been very financially rewarding. This job is not for everybody. The person has to really like animals and not mind the twice-daily chores. We milk at 12-hour intervals and NEVER skip a milking, because twice-a-day milking is very important to decent milk production.

My advice to farmers—do not go overboard on expenses. Be practical.



# Resources

## Contacts

An excellent source of information is the Hometown Creamery Revival Project. This project is funded by the Sustainable Agriculture Research and Education (SARE) program of the USDA and managed by Vicki Dunaway. The Hometown Creamery Revival promotes on-farm processing as a means of making dairying a sustainable way of life for small farms. For additional information about this project, contact:

Vicki Dunaway  
Hometown Creamery Revival Project  
P.O. Box 186  
Willis, VA 24380  
540-789-7877 (call before 9  
p.m. Eastern time)  
ladybug@swva.net  
www.ibiblio.org/creamery

Currently the project produces a quarterly newsletter, *CreamLine*, and maintains a Web site with a list of equipment suppliers, events, and links to other relevant Web sites. A free sample issue of *CreamLine* is available on request. *CreamLine* takes a holistic approach to farmstead and small-scale dairying and includes farm interviews and stories, recipes, a chef's column, processing instructions, guest articles, and lists of resources. There is also a companion magazine called *Home Dairy News*. These can be ordered by visiting [www.small-dairy.com/news.html#order](http://www.small-dairy.com/news.html#order).

The first major publication of the Hometown Creamery Revival was *The Small Dairy Resource Book*. It is a 56-page annotated bibliography of books, periodicals, videos, and other materials on farmstead dairy processing. It is intended for farmers and others interested in adding value to dairy products. The resources cover such topics as on-farm cheesemaking, ice cream, butter, dairy processing, business and marketing, food safety, and feeds and grazing. The book can be ordered from:

Sustainable Agriculture Publications  
Hills Building, Room 210  
University of Vermont

Burlington, VT 05405-0082  
802-656-0484 (to order with  
Visa or Master Card).

To order, send \$8.00, plus \$3.95 for postage, by check or money order, or visit [www.sare.org/san/htdocs/pubs/](http://www.sare.org/san/htdocs/pubs/). You may also print a copy from the Web.

Steve Hart, Terry Gipson, and Steve Zeng at Langston University's Institute for Goat Research are valuable sources of information. Langston has a Grade A goat dairy. They can be contacted at:

E. (Kika) de la Garza American In-  
stitute for Goat Research  
Langston University  
P.O. Box 1730  
Langston, OK 73050  
405-466-3836  
[www.luresext.edu/goats/index.htm](http://www.luresext.edu/goats/index.htm)

Prairie View A&M University is another dairy goat research center.

International Dairy Goat Research Center  
Prairie View A&M University  
Prairie View, TX 77446  
409-857-3926

Carol Delaney is the Small Ruminant Dairy Specialist at the Vermont Small Ruminant Dairy Project. She can be reached at:

Vermont Small Ruminant Dairy Project  
200B Terrill Hall  
University of Vermont  
Burlington, VT 05405  
802-656-0915  
carol.delaney@uvm.edu  
[www.uvm.edu/sustainableagriculture/  
?Page=srdp.html&SM=archivemenu.html](http://www.uvm.edu/sustainableagriculture/?Page=srdp.html&SM=archivemenu.html)

Dr. George Haenlein was a Dairy Extension Specialist at the University of Delaware. He is retired, but still answers questions about dairy goat production.

Dr. George Haenlein  
Dairy Extension Specialist  
University of Delaware  
531 S. College Ave.  
039 Townsend Hall  
Newark, DE 19717  
302-831-2524

Judy Kapture and her husband operate a commercial dairy where they milk 150 does, supplying milk to a cheese plant and to a Grade A market. She is also a dairy-goat consultant.

Judy Kapture  
P.O. Box 298  
Portage, WI 53901  
608-742-1622 FAX

New England Dairy/Meat Goat and Dairy  
Sheep Directory

This directory was developed through the Center for Sustainable Agriculture's Small Ruminant Dairy Project, and lists producers, service providers, and resources for farming with dairy goats, dairy sheep, and meat goats in Vermont, New Hampshire, Maine, Rhode Island, Connecticut, and Massachusetts. Producers are listed alphabetically by state/town, and indexed by breed; service providers are listed alphabetically and indexed by state/town. The directory also lists resources, including programs, associations, and periodicals. \$5.00 suggested donation per copy to cover copying/shipping/handling. To order or for more information, call 802-656-5459 or e-mail [sustainable.agriculture@uvm.edu](mailto:sustainable.agriculture@uvm.edu). Or you can mail your order to Center for Sustainable Agriculture, 63 Carrigan Drive, Burlington, VT 05405. Make checks payable to "UVM". No credit card orders.

## SARE Project Producers

Below are some producers who have done SARE projects with dairy goats. You can visit the SARE Web site at [www.sare.org](http://www.sare.org) to search all projects and read the specifics of these producers' projects. This site also links to the Regional SARE pages.

George van Vlaanderen and Kristan Doolan  
Does' Leap Farm  
1703 Rt. 108 South  
East Fairfield, VT 05448

Darrell Baker  
Box 1776  
Tucumcari, NM 88401

Brit Pfann  
Celebrity Dairy  
144 Celebrity Dairy Way  
Siler City, NC 27344  
919-742-5176  
[theinn@celebritydairy.com](mailto:theinn@celebritydairy.com)  
[www.celebritydairy.com](http://www.celebritydairy.com)

Lee B. Dexter  
White Egret Farm  
15704 Webberville Road  
Austin, TX 78724  
512-276-7408

Tim Pedrozo  
Pedrozo Dairy and Cheese Company  
7713 County Road 24  
Orland, CA 95963  
530-865-9548

## Web sites

University of California Cooperative Extension

[www.vetmed.ucdavis.edu/vetext/INF-GO\\_CarePrax2000.pdf](http://www.vetmed.ucdavis.edu/vetext/INF-GO_CarePrax2000.pdf)  
*On-line publication Goat Care Practices*

Georgia Goat Research & Extension Center,  
Fort Valley State University

[www.ag.fvsu.edu/srrec/newsletter.cfm/](http://www.ag.fvsu.edu/srrec/newsletter.cfm/)  
*Georgia Small Ruminant Research & Extension Center newsletters and publications*

Dairy Research & Information Center, University of California – Davis

<http://drinc.ucdavis.edu/html/milkg/milk-3.shtml>

American Dairy Goat Association

[www.adga.org/](http://www.adga.org/) and  
[www.adga.org/StartDairy.htm](http://www.adga.org/StartDairy.htm)  
*On-line publication Starting a Grade A or Grade B Goat Dairy*

Langston University

[www.luresext.edu/goats/index.htm](http://www.luresext.edu/goats/index.htm)  
[www.luresext.edu/goats/library/fact\\_sheets/d04.htm](http://www.luresext.edu/goats/library/fact_sheets/d04.htm)  
*On-line publication Grade A Dairy Goat Farm Requirements*  
[www.luresext.edu/goats/library/field/hart02.html](http://www.luresext.edu/goats/library/field/hart02.html)

*On-line article* Forage Based  
Dairy Goat Management

North Carolina State University- Extension  
Animal Husbandry (see Meat Goat)

[www.cals.ncsu.edu/an\\_sci/extension/  
animal/eahmain.html](http://www.cals.ncsu.edu/an_sci/extension/animal/eahmain.html)

Oklahoma State University

[www.ansi.okstate.edu/breeds/goats](http://www.ansi.okstate.edu/breeds/goats)  
*Descriptions and pictures of goat breeds*

University of Florida Institute of Food and Ag-  
ricultural Sciences

<http://edis.ifas.ufl.edu/DS134>  
*On-line publication Dairy Goat Pro-  
duction Guide. A great resource.*

The Hometown Creamery Revival

[www.smalldairy.com](http://www.smalldairy.com)

National Scrapie Education Initiative

[www.eradicatescrapie.org/index.html](http://www.eradicatescrapie.org/index.html)  
*Information about the Scrapie  
Eradication Program*

Celebrity Dairy in North Carolina

[www.celebritydairy.com](http://www.celebritydairy.com)

Goat Lady Dairy of North Carolina

[www.goatladydairy.com](http://www.goatladydairy.com)

## Associations

Annual membership to the American Dairy Goat Association costs \$35 and includes a quarterly newsletter and a membership directory that is updated each year. The ADGA offers educational materials; a list of national breed clubs; a production calendar; a list of upcoming meetings, shows and youth programs; and videos about goat basics, showing, and cheese-making; etc.

American Dairy Goat Association  
Box 865  
Spindale, NC 28160  
828-286-3801  
828-287-0476 FAX  
[info@adga.org](mailto:info@adga.org)  
[www.adga.org](http://www.adga.org)

The American Cheese Society also has lists of resources and other practical information avail-

able to its members. Membership is \$125 for individuals and \$75 for associates.

American Cheese Society  
P.O. Box 303  
Delavan, WI 53115  
262-728-4458  
262-728-1658 FAX  
[www.cheesesociety.org](http://www.cheesesociety.org)

## Periodicals

The *Dairy Goat Journal* is published bi-monthly. It offers articles describing dairy goat operations and provides many resources and other helpful contacts.

Dairy Goat Journal  
Countryside Publications, Ltd.  
W11564 Hwy 64  
Withee, WI 54498  
715-785-7979  
800-551-5691 (toll-free)  
715-785-7414 FAX  
[csymag@midway.tds.net](mailto:csymag@midway.tds.net)  
[www.dairygoatjournal.com](http://www.dairygoatjournal.com)  
Subscription is \$21 per year.

The United Caprine News  
P.O. Box 328  
Crowley, TX 76036  
817-297-3411  
[www.unitedcaprinenews.com](http://www.unitedcaprinenews.com)  
Subscription is \$22.50 per year.

## Suppliers

Caprine Supply  
P.O. Box Y  
DeSoto, KS 66018  
913-585-1191  
800-646-7736 (toll-free)  
[www.caprinesupply.com](http://www.caprinesupply.com)

Hoegger Supply Company  
P.O. Box 331  
Fayetteville, GA 30214  
770-461-6926  
800-221-4628 (ordering only)  
770-461-7334 FAX  
[www.hoeggergoatsupply.com](http://www.hoeggergoatsupply.com)

Hamby Dairy Supply  
2402 SW Water Street  
Maysville, MO 64469-9102



800-306-8937 (toll-free)  
www.hambydairyresource.com

Pladot Marketing Dept.  
Bob Turner, National Sales Manager  
717-338-0671  
turnerr@cvn.net  
www.pladot.co.il

Efrem Enterprises Ltd.  
Michael J. Kozushka, Marketing Director  
Box 117  
Yorkton, Saskatchewan, Canada S3N-2V6  
306-783-5888  
306-783-9399 FAX  
efrem@htmnet.com

## Books

Some of the following books are available from bookstores and on-line booksellers. If a book is listed as out-of-print, you may be able to obtain it through Interlibrary Loan; check with your local librarian. You may also be able to buy a copy through an on-line used-book search site. Many goat supply companies offer many of these listed books, as well as other books related to dairy goats and their products.

### **Guidelines for Production and Regulation of Quality Dairy Goat Milk**

Publication DPC 59. Dairy Practices Council. Updated in 2000. Cost is \$4.00 plus \$2.50 shipping.

Order from:  
Dairy Practices Council  
51 E. Front Street, Suite 2  
Keyport, NJ 07735  
732-203-1947  
www.dairypc.org

### **The Legal Guide for Direct Farm Marketing**

Hamilton, Neil. 1999. Drake University, Des Moines, IA. 240 p. Cost \$23.00 including shipping.

Order from:  
Neil Hamilton  
Drake University Law School  
Agricultural Law Center  
2507 University Ave.  
Des Moines, IA 50311  
515-271-2947

### **Vermont Dairy Goat Manual**

Vermont Dairy Goat Promotion Board. 1994. Vermont Dairy Goat Promotion Board and Vermont Department of Agriculture. 15 p. No charge.

Order from:  
Vermont Department of Agriculture  
116 State St., Drawer 20  
Montpelier, VT 05620-2901  
802-828-2416

### **Home Cheese Making: Recipes for 75 Home-made Cheeses**

Carroll, Ricki, and Laura Werlin. 2002. Storey Books. 278 p. Cost \$16.95 plus \$4.00 shipping.

Order from:  
Storey Publishing, LLC  
800-441-5700 (toll-free)  
www.storey.com

### **The New Goat Handbook**

Jaudas, Ulrich. 1989. Barrons Educational Series, Inc. 104 p. Cost \$11.95 plus \$5.95 shipping.

Order from:  
Barrons Educational Series, Inc.  
250 Wireless Blvd.  
Hauppauge NY, 11788  
800-645-3476 (toll-free)  
631-434-3723 FAX  
www.barronseduc.com

### **Raising Milk Goats Successfully**

Luttman, Gail. 1986. Williamson Publishing. 172 p. Cost \$9.95 plus \$4.00 shipping.

Order from:  
Williamson Publishing  
P.O. Box 185  
771 Cedar Beach Road  
Charlotte, VT 05445  
800-234-8791

### **Goats Produce, Too!: The Udder Real Thing**

Toth, Mary Jane. 1998. Volume II, 6th edition. 136 p. Cost \$12.95 plus \$2.00 shipping.

Order from:  
Mary Jane Toth  
2833 N. Lewis Road  
Coleman, MI 48618  
989-465-1982

### **Goatowner's Guide to Milking Machines**

Gray, Diane. 1997. Stringalong Enterprises. Wauchula, FL. Out of print.

### **Cheesemaking Made Easy**

Carroll, Ricki, and Robert Carroll. 1995. Storey Communication. Pownal, VT. 144 p.

### **Building a Sustainable Business: A Guide to Developing a Business Plan for Farms and Rural Business**

DiGiacomo, Gigi, Robert King, and Dale Nordquist. 2003. Minnesota Institute for Sustainable Agriculture, Saint Paul, MN, and the Sustainable Agriculture Network, Beltsville, MD.

Available for \$14.00 + \$3.95 S/H by calling 802-656-0484 or 800-909-6472.

Publication can also be viewed at [www.misa.umn.edu/publications/bizplan.html](http://www.misa.umn.edu/publications/bizplan.html).

## **Budgets**

Sample budgets are available from the following sources.

Minnesota Extension Service. St. Paul, MN 55108. AG-FO-3606. Appleman, 1989. Order from [order@dc.mes.umn.edu](mailto:order@dc.mes.umn.edu). Economics of the Dairy Goat Business.

Pennsylvania State University Web site at

[http://agalternatives.aers.psu.edu/Publications/dairy\\_goat.pdf](http://agalternatives.aers.psu.edu/Publications/dairy_goat.pdf) (Includes helpful article and resource list.)

Vermont Small Ruminant Dairy Project. Contact Carol Delaney at 802-656-0915.

Vermont Dairy Goat Promotion Board/Vermont Dept. of Agriculture. Published in Dairy Goat Journal, September 1994. p. 16-17.

Rutgers Cooperative Extension

<http://aesop.rutgers.edu/~farmmgmt/ne-budgets/ORGANIC/DAIRY-GOAT-2100LB-MILK.HTML>

<http://aesop.rutgers.edu/~farmmgmt/ne-budgets/ORGANIC/DAIRY-GOAT-1800LB-MILK.HTML>

There are many goat and dairy goat discussion groups located at [www.groups.yahoo.com](http://www.groups.yahoo.com).

## **References**

Appleman, R. 1989. Economics of the Dairy Goat Business. The Minnesota Extension Service. St. Paul, MN. 5 p.

Baker, D. 1998. Increasing the value of irrigated pasture-grazing goats on a small dairy farm. The Farm Connection. Vol. 6, No. 1. p 6.

Considine, H. 1999. Most frequent mistakes made by beginners and "pros." Dairy Goat Journal. July. p. 20-25.

Considine, H. 1996. Dairy Goats for Pleasure and Profit. Dairy Goat Journal Books.

Dairy Practices Council. 1994. Guidelines for Production and Regulation of Quality Dairy Goat Milk. Publication DPC 59. Dairy Practices Council. Keyport, NJ. 17 p.

Dunaway, V. 2000. The Small Dairy Resource Book. SARE. Sustainable Agriculture Network, Beltsville, MD. 56 p.

Haenlein, G.F.W. 1996. Status and prospects of the dairy goat industry in the United States. Journal of Animal Science. Vol. 74, No. 5. p. 1173-1181.

Hamilton, N. 1999. The Legal Guide for Direct Farm Marketing. Drake University, Des Moines, IA. 240 p.

Harris, B., and F. Springer. 1996. Dairy Goat Production Guide. University of Florida Cooperative Extension Service CIR 452. 11 p.

Hart, S. E. (Kika) de la Garza American Institute for Goat Research, Langston University. E-mail from author, January 2004.

Kapture, J. 2001. Ask Judy. Dairy Goat Journal. Vol. 79, No. 1. p. 17.

Levesque, P. 2004. Teat Sanitation: What are your options? Hoard's Dairyman. January 10. p. 9.

Morand-Fehr, P., and D. Sauvant. 1978. Nutrition and optimum performance of dairy goats. *Livestock Production Science*. Vol. 5, No. 2. p. 203-213.

Mowlen, A. 1992. *Goat Farming*. Farming Press Books, Ipswich, United Kingdom. 200 p. (Distributed in the U.S. by Diamond Farm Enterprises, Alexandria Bay, NY.)

Pennington, J. No date. Herd Health Program for Dairy Goats. University of Arkansas Cooperative Extension Service. 2 p.

Pfann, B., and F. Pfann. Owners of Celebrity Dairy. Unpublished presentation at SSAWG, 2002.

Sahs, R. 2003. Goat farm budgeting. *In: Proceedings of the 18th Annual Goat Field Day*. E. (Kika) de la Garza American Institute for Goat Research, Langston University, Langston, OK. p. 47-48.

Salama, A. A. K. 2003. Effects of once versus twice daily milking throughout lactation on milk yield and milk composition in dairy goats. *Journal of Dairy Science*. Vol. 86, No. 5. p. 1673-1680.

Smith, M. 1994. *Goat Medicine*. Lippincott Williams and Wilkins, Baltimore, MD. 620 p.

Specialty Cheese Market. 2001. Prepared by Food Processing Center, Institute of Agriculture and Natural Resources, University of Nebraska-Lincoln. 62 p.

Stanton, t. Extension Associate, Department of Animal Science, Cornell University. E-mail from author, 2002.

Thompson. 1997. Couple switches from spinach to 90 Nubian milkers. *Dairy Goat Journal*. Vol. 75, No. 7. p. 8-11.

Tolman, B. 2002. Introduction to Dairy Sheep Farming-Getting Started. *In: Proceedings of the 8th Great Lakes Dairy Sheep Symposium*. Cornell University, Ithaca, NY. p 2.

Zeng, S., and E.N. Escobar. 1995. Grade A Dairy Goat Farm Requirements. [www.luresext.edu/goats/library/fact\\_sheets/d04.htm](http://www.luresext.edu/goats/library/fact_sheets/d04.htm). 8 p.

This publication is frequently updated. Your comments and suggestions are most welcome; please call ATTRA to let us know what other information should be included.

Linda Coffey  
lindac@ncat.org  
800-346-9140 (toll-free)

The ATTRA Project is operated by the National Center for Appropriate Technology under a grant from the Rural Business-Cooperative Service, U.S. Department of Agriculture. These organizations do not recommend or endorse products, companies, or individuals.

**By Linda Coffey, Margo Hale,  
and Paul Williams**  
**NCAT Agriculture Specialists**  
**Formatted by Robyn Metzger**  
**© 2004 NCAT**



The electronic version of Dairy Goats: Sustainable  
Production is located at:  
HTML  
<http://www.attra.ncat.org/attra-pub/dairygoats.html>  
PDF  
<http://www.attra.ncat.org/attra-pub/PDF/dairygoats.pdf>

IP 258  
Slot 249  
Version 081704



# Sheep: Sustainable and Organic Production

By Margo Hale,  
Linda Coffey  
NCAT Program  
Specialists

Ann Bartlett,  
Chelsey Ahrens  
NCAT Interns  
© 2010 NCAT

## Contents

- Introduction.....1
- Breed selection.....1
- Feeding ruminants.....3
- Reproduction.....8
- Health.....9
- Facilities.....12
- Marketing.....13
- Organic production.....17
- Economics.....20
- Conclusion.....22
- References.....22
- Further resources.....22

This publication introduces concerns and practices specifically related to sustainable sheep production. Topics covered include breed selection, controlled grazing, pasture lambing, alternative health management, and innovative marketing of meat and wool products. A list of further resources is also included.

## Introduction

For the established farmer seeking to diversify, sheep offer a number of benefits. Sheep can easily be integrated into an established farm and are a good complement to cattle. Integrating sheep into a farming operation can also contribute to the economic and environmental sustainability of the whole farm. Sheep will enhance a farm’s biological diversity and may fit economic and biological niches that would otherwise go unfilled. The relatively small investment required, and the gradually increasing size of the flock, also make sheep production a good choice for beginning, small-scale, or part-time farmers.

It is important to learn as much as you can before beginning a sheep enterprise. General sheep production information — such as feeding, breeding, and health management — is available in local or state Cooperative Extension Service publications. The **Resources** section at the end of this publication provides further sources of information, including books, magazines, websites, and organizations. We strongly encourage you to supplement your reading by contacting and visiting sheep producers in your area.

Sheep can be incorporated into existing grazing operations with goats, cattle, or horses. In fact, multi-species grazing is useful in increasing pasture efficiency. It has been demonstrated that grazing sheep with cattle can increase total meat production by 24% compared to raising cattle alone, and by 9% compared to raising sheep alone.



Sheep production is a good choice for beginning, small-scale, or part-time farmers. Photo by Linda Coffey, NCAT.

(Walker, 1994) See the ATTRA publication *Multispecies Grazing* for more information.

## Breed selection

Breed selection is based on the intended market(s), on local climate, and personal preference. Breeds can be divided into eight categories.

What breed(s) you choose to work with will depend on your needs and interests. Common breeds are Suffolk, Hampshire, Rambouillet, and Dorset. Hair sheep breeds include Katahdin, St. Croix, Dorper, and Barbados Blackbelly. All breeds have advantages and disadvantages. Crossbreeding is very common



## Related ATTRA Publications

Small Ruminant Sustainability Checksheet

An Illustrated Guide to Sheep and Goat Production

Dairy Sheep

Breed Category	Description	Example
General purpose	Good balance between sire and dam traits	Dorset, North County Cheviot, Montadale
Maternal	Good adaptability to more difficult environments; above-average fleece; primarily found in range areas	Merino, Rambouillet, Targhee, Columbia, Polypay
Prolific maternal	Very large numbers of lambs (average three or more per ewe); excellent newborn vigor	Finnsheep, Romanov
Sire	Large mature size; rapid growth; superior muscling; lower carcass fat	Suffolk, Hampshire, Oxford, Shropshire, Texel, Southdown
Dairy	Specialized for milk production	East Friesian, Lacaune
Hair (meat)	Don't have wool; adapted to hot, humid climates; parasite tolerant	Katahdin, Dorper, St. Croix, Barbados Blackbelly
Specialized or long wool	Produce colored fleeces or fleeces with other unique characteristics; desired by fiber artists	Shetland, Icelandic, Lincoln, Border Leicester, Romney
Hobby or rare	Not typically used for commercial production; may be raised for exhibition, breeding stock, or to preserve the breed; may possess traits of importance to production in the future	Jacob, Cotswold, Navajo-Churro, Gulf Coast Native

Table adapted from "Changes in the Sheep Industry in the United States." 2008. National Research Council. Chapter 2.

and allows for lambs to have desirable characteristics of more than one breed. Your farm goals should dictate what breed(s) of sheep you choose and whether or not you crossbreed. It is also important to remember that there is just as much variation among animals of the same breed as there is among animals of different breeds.

For more information on the various breeds, contact the American Sheep Industry Association ([www.sheepusa.org](http://www.sheepusa.org)) or visit the Oklahoma State University livestock breeds web page ([www.ansi.okstate.edu/breeds/sheep](http://www.ansi.okstate.edu/breeds/sheep)). The book *Storey's Illustrated Breed Guide to Sheep, Goats, Cattle, and Pigs*, by Carol Ekarius, is another good source of breed information. The American Livestock Breeds

Conservancy ([www.albc-usa.org](http://www.albc-usa.org)) has information on rare and heritage breeds. For more information and research on hair sheep breeds, see the proceedings of the Hair Sheep Workshop ([www.sheepandgoat.com/HairSheepWorkshop](http://www.sheepandgoat.com/HairSheepWorkshop)).

When selecting animals for your flock, you must first decide what traits are important to you and what the animals will be used for. Find producers with the types of animals that you are interested in. You can locate producers by contacting your local extension agent, searching classified ads in sheep publications, viewing online directories, contacting sheep clubs or associations, or by attending meetings or seminars for sheep producers. Once you have found a producer with sheep for sale, visit the farm to observe the flock and the management. The animals will adapt more easily to your farm if their prior management and environment are similar to yours.

To develop a productive flock, it is imperative that you select healthy animals. Never build your flock with animals from a sale barn. These are often animals that have been culled by another producer. There is a reason why they were culled, and you do not want

Wooled Sheep Considerations	Hair Sheep Considerations
Growth and carcass characteristics	Less seasonal than woolled sheep
Accepted in the traditional markets	Higher lambing percentages than many woolled breeds
Produce marketable wool	Some breeds show resistance to internal parasites
Widely available	Heat tolerant
	No wool to shear or market
	Don't have to dock tails

to bring those problems to your flock. Don't purchase animals that are limping, look sick, or are lagging behind the others. Always purchase animals that are lively and look alert. Select animals that have sound feet and legs and a proper bite (not over-shot or under-shot). It is helpful to bring an experienced sheep producer to assist you in selecting animals that are likely to be healthy and productive.

Listed below are some of the signs of a healthy animal.

- Lively manner
- Easy movement (no limping, swollen joints, or misshaped or hard udders)
- Proper conditioning (not overly fat or excessively thin)
- Well-shaped udder and teats

Question the producer about the flock. For example, ask what diseases have been problems in the flock, what the vaccination and deworming protocol is, and what criteria are used for selection and culling. Also ask your veterinarian about diseases that could be a problem in your area.

To run an efficient operation, it is necessary to identify animals (usually by tattoos or eartags) and keep records. Breeding, reproduction, health, and production records are helpful in identifying which animals are most productive and which should be culled. Sample record-keeping forms can be found at [www.sheepandgoat.com](http://www.sheepandgoat.com).

## Feeding ruminants

Sheep will typically consume two to four percent of their body weight (on a dry matter

basis) each day in feed. Animal size, stage and level of production, animal activity, and environmental conditions all influence an animal's nutritional requirements. A variety of feedstuffs can be used to meet your animals' nutritional needs.

Forage from brush, pasture, and range can be maximized as low-cost feeds. Sheep, as ruminants, convert forage that would otherwise be unusable into high-quality fiber, meat, and milk. Like cattle, sheep are grazers; like goats, they also consume woody browse (tree forage and shrubs) and forbs (herbaceous plants). Sheep are less dependent on harvested grains than dairy cattle, swine, and poultry.

Sheep are ruminants, named for the rumen — the largest compartment of the stomach. The health and productivity of sheep, as with all ruminants, depends on healthy rumen function. Microorganisms in the rumen digest fiber, carbohydrates, and protein to supply the animal with nutrients. It is essential that the animals be fed appropriately so that these organisms stay healthy.

The rumen organisms require fiber, nitrogen (protein), and energy (carbohydrates). The microorganisms prefer a pH range of 6 to 6.8. The digestion of grain (especially finely ground grains) lowers the rumen pH. If sheep eat too much grain, their ruminal pH can drop too low and make them very sick. The rumen microorganisms are healthiest when sheep are eating high-quality forages such as vegetative pasture. When grain (or more grain) is added to the ration, the rumen needs time to adjust. For more information, see ATTRA's *Ruminant Nutrition for Graziers*.

Lambing						
Animal ID	Bred	Due	Lambled	No. in litter	Sire	Comments

An example breeding record form.

Pastures: Sustainable Management

Pasture, Rangeland, and Grazing Management

Ruminant Nutrition for Graziers

Rotational Grazing

Paddock Design, Fencing, and Water Systems for Controlled Grazing

Managed Grazing in Riparian Areas

## Pasture grazing

Improving pasture and extending the grazing season are important in forage-based sheep operations. Depending on the climate, it may be possible to improve pastures with cool season perennials (tall fescue, orchardgrass), warm season annuals (crabgrass, dwarf pearl millet), cool season annuals (annual ryegrass, oats, wheat), and a few warm season perennials (bahiagrass, bermudagrass) to provide year-round forage. The addition of legumes (alfalfa, clover, lespedeza, birdsfoot trefoil) to a pasture provides high-quality protein and reduces the need for nitrogen fertilizer. Sheep may also be pastured on small grains or root crops (brassicas). Feeding harvested products such as hay and concentrates (grain) is usually a higher-cost practice. The term “grass-farming” reflects the understanding that the livestock grazer’s primary product is high-quality pasture, the prerequisite for healthy animals and healthy profits. For more information on pastures, see ATTRA’s *Pastures: Sustainable Management*.

The best grazing system for efficient use of pasture is controlled grazing, or management-intensive rotational grazing. In controlled grazing, pastures are divided into smaller units called paddocks. The sheep are kept in

a paddock until they have grazed the forage down to a predetermined height, and then rotated to the next paddock. They are not returned to a paddock until the plants have regrown to the height needed for availability and quality. Sheep prefer to eat forage no taller than six inches; forage should be grazed no lower than three inches. Controlled grazing reduces both selectivity and repeated grazing pressure — letting plants develop more foliage before being grazed again — while increasing pasture diversity. Although rotational systems require initial expenditures for fencing and water facilities, many producers report increased profitability based on lower input and feed costs, less dependence on machinery, and improvement and better use of pasture.

When grazing sheep, farmers must protect their pastures from being overgrazed. There are several reasons for this. Overgrazing forages:

- Eventually kills the plants
- Reduces the longevity of the stand and exposes more soil to erosion
- Means the animals don’t get enough food
- Increases the chance of sheep ingesting infective internal parasite larvae

### Environmental impacts and sustainable sheep production

There are substantial environmental benefits associated with sustainable sheep production. These include low embodied energy in feed — all the energy used during feed production — and low releases of emissions such as carbon dioxide (CO<sub>2</sub>), nitrous oxide (N<sub>2</sub>O) and methane (CH<sub>4</sub>).

Generally, sustainable sheep production is pasture-based and requires little or no supplemental feed. Producing forage on-site and without the use of energy-intensive inputs including fertilizers, herbicides, and fuels to dry and store feed, generally lowers the embodied energy in sheep feed. When feeding native hay and grains that are produced locally, the energy required

for transportation is reduced further due to shorter distances between the feed source and the sheep. Since fossil fuels are primary sources of greenhouse gas emissions such as CO<sub>2</sub>, using fewer energy inputs usually reduces emissions as well.

Providing sheep with access to pasture forage improves the ecological balance between forage and livestock. Pastured sheep efficiently close the loop between harvesting forage and returning nutrients to the soil, and with less energy than if forage were harvested and hauled from the pasture and manure was then hauled back out onto the pasture. Distributing manure and urine on the pasture

also reduces methane emissions from manure slurry.

Proper soil and pasture management can also mitigate the release of emissions. Under certain soil conditions, N<sub>2</sub>O emissions are released from the soil through a process called denitrification. An excessive buildup of manure and urine (nitrogen, ammonium) in water-saturated soils can lead to denitrification and the release of N<sub>2</sub>O, a greenhouse gas 310 times more powerful than CO<sub>2</sub>. Rotating animals through pastures and moving feeding, watering, and shade areas will help spread the manure and urine out more uniformly and may help decrease N<sub>2</sub>O emissions from pasture soils.



- Creates bare spots, creating opportunities for undesirable weeds and erosion.

The end result of overgrazing is reduced performance of both the pasture and the animals, as well as health problems for the animals. To prevent overgrazing, farmers should be careful to understock rather than overstock land and always remove animals from a pasture when the pasture is grazed down to about three to four inches.

Fresh, clean water must always be available. Adult sheep require approximately one gallon of water per day. In a rotational grazing system, the animals either have access to a central water source available to every subdivision, or water is provided separately to each of the pasture's subdivisions. This can be a challenge and an additional capital expense. For more information, see ATTRA's *Pasture, Rangeland, and Grazing Management*.

## Predation

Sheep are animals of prey due to their size and nature, so they are susceptible to predation. Predators range from coyotes and mountain lions to neighborhood dogs. The first line of defense should be strong, adequate fencing. But most of the time fencing is not enough. Livestock can be protected by guardian animals, including donkeys, llamas, and most commonly, guardian dogs. The most widely used livestock guardian breeds are Great Pyrenees, Anatolian Shepherds, Komondors, and Kuvaszes. For more information on how to control predators, see the ATTRA publication *Predator Control for Sustainable and Organic Livestock Production*.

## Range grazing

Rangeland is land historically dominated by grasses, forbs, or shrubs. Rangeland also includes land revegetated and managed like native vegetation. Some rangeland types are natural grasslands, savannas, most deserts, tundra, alpine plant communities, coastal and freshwater marshes, and wet meadows. (USDA, 2003) The natural diversity, topography, climate, and extent of rangelands in the U.S. make rangelands well-

## Fencing

When raising sheep on pasture, adequate fencing is essential. Good fencing allows you to control grazing, helps save you the frustration of having to chase sheep back into the pasture, and helps protect against predators. Fencing will also be the greatest expense, other than the initial cost of the animals. Traditional sheep fencing is a four-foot woven wire with barbed wire along the top. Four or more strands of high-tensile electric wire is a more economical fencing choice. Strands of polywire can be used for temporary paddocks. Sheep may have to be trained to electric fences by placing them in a small paddock to "test" the wire. Electric netting is also an option for temporary fencing in controlled grazing systems. Regular checking and testing of fences is necessary, and any problems must be fixed promptly, or sheep will escape. Sheep will respect electric fencing better if it is hot (>3000 volts).

These animals are hardest to fence:

- Rams
- Lambs at weaning
- Hungry sheep (not enough forage in their pasture)
- Sheep in full fleece



Photo courtesy of Susan Schoenian, University of Maryland

sited to sheep grazing. However, rangelands have historically been over-exploited to the detriment of many range sites, especially in the western U.S. Nowadays, range managers and researchers are making significant inroads toward the development of sustainable rangeland grazing systems that are naturally regenerative; allowing for the production of livestock while restoring sensitive rangeland.

About 48% of sheep produced in the U.S. are raised in 10 western rangeland states. (NASS, 2010) Sheep are well adapted to



A Great Pyrenees guards his flock. Photo by Susan Schoenian, University of Maryland.



Sheep are well adapted to rangeland grazing. Photo by Susan Shoenian, University of Maryland.

### Copper

Sheep are very sensitive to copper. They require lower levels than other livestock. Be sure to feed mineral mixes and other feed products that have been specifically formulated for sheep.

rangeland grazing because of their body size relative to cattle, their grazing and browsing behavior that relies on a more diverse diet than cattle, and, especially, their ability to graze weedy plants such as leafy spurge and spotted knapweed.

Range managers have known for years that grazing can damage rangeland health for decades. Through observation of rangeland ecology and grazing animal behavior, successful grazing managers realize that animal impact can have a positive influence on rangeland health as well.

A good example of management to positively affect rangeland health is called targeted grazing. According to Launchbaugh and Walker (2006), targeted grazing is the application of a specific kind of livestock at a determined season, duration, and intensity to accomplish defined vegetation or landscape goals. As opposed to good grazing management, which range managers are becoming quite good at, targeted grazing refocuses the results of grazing from livestock production to vegetation and landscape enhancement. (Launchbaugh and Walker, 2006)

For more information on targeted grazing and using sheep to control weeds, see the publication *Targeted Grazing: A Natural Approach to Vegetation Management and Landscape Enhancement* ([www.cnr.uidaho.edu/rx-grazing/Handbook.htm](http://www.cnr.uidaho.edu/rx-grazing/Handbook.htm)).

## Supplemental feeding

Wintertime or dry-period feeding may include supplements in addition to hay. Grain (corn, barley, oats) is used as a supplement to provide energy. Soybean or cottonseed meal is used to provide protein. Other potential feedstuffs include crop residues such as cornstalks, crops spoiled by wet weather, cull vegetables, and by-products from cereal milling, wheat milling, and food processing.

Trace-mineralized salt or other mineral supplements are also needed. It is best to feed calcium, phosphorous, and trace minerals in the grain or in a salt mixture to ensure that the animals actually eat them. Test your

forages to determine their mineral content, and adjust mineral supplementation as needed. Your local Extension agent can have your forage analyzed. Mineral content of forage is quite variable across the country, and the type, stage, and level of production of the animal influences mineral requirements. Therefore, no one mineral supplement formula is right for all locations or situations. It is very important that you consistently offer mineral mix (preferably in a loose form), monitor its consumption, and ensure that all the sheep are in fact eating adequate amounts of the mineral supplements. The website [www.sheepandgoat.com](http://www.sheepandgoat.com) has additional resources on proper nutrition and feeding of sheep.

Ration-balancing ensures that animals receive the necessary amounts of nutrients (energy, protein, vitamins, and minerals). By using the National Research Council's The Nutrient Requirements of Sheep (see References) and their chart of the nutrient make-up of various feedstuffs, a producer can determine the amounts of nutrients their sheep should receive. If laboratory feed analysis is available, it should be used instead. Advice from a local Extension agent can be helpful in balancing least-cost rations. Montana State University has a website for balancing sheep rations, [www.msusheeppration.montana.edu](http://www.msusheeppration.montana.edu).

## Body condition scoring

Your goal in feeding your animals is to meet their nutritional requirements (economically) and to keep them in a productive condition. One way to monitor the animals' condition is to assign body condition scores (BCS). Body condition scoring evaluates the body fat reserves of your sheep and is an easy method to evaluate the effectiveness of your feeding program. To do this with sheep, you must use your hands to feel the animal — wool and hair make it impossible to see accurately.

Body condition scoring is based on the amount of muscling and fat deposition over and around the vertebrae in the loin region. Scores range from 1 to 5, with 1 being emaciated and 5 being obese. For most of the life cycle of the sheep, the goal is to keep them in moderate condition (3). When ewes are nursing twins some weight loss is expected. Even with good feed, body condition may be a 2.

It is a good idea to monitor the body condition of your flock before breeding, before lambing, after lambing (while nursing), and at weaning. You should adjust your feeding program to allow most of your flock to maintain moderate condition. Body condition scoring can also be used to determine market readiness.

Body Condition Scores	
Score 1	<p>Sheep is extremely thin, unthrifty but agile.</p> <p>Skeletal features are prominent with no fat cover.</p> <p>No apparent muscle tissue degeneration.</p> <p>Has strength to remain with the flock.</p>
Score 2	<p>Sheep is thin but strong and thrifty with no apparent muscle structure wasting.</p> <p>No evident fat cover over the backbone, rump, and ribs, but skeletal features do not protrude.</p>
Score 3	<p>Sheep are thrifty with evidence of limited fat deposits in fore rib, over top of shoulder, backbone, and tail head.</p> <p>Hipbone remains visible.</p>
Score 4	<p>Moderate fat deposits give the sheep a smooth external appearance over the shoulder, back, rump, and fore rib.</p> <p>Hip bone is not visible.</p> <p>Firm fat deposition is evident in brisket and around the tail head.</p>
Score 5	<p>Sheep are extremely fat with the excess detectable over the shoulder, backbone, rump, and fore rib. Excess fat deposits in brisket, flank, and tail head regions lack firmness.</p> <p>Sheep appear uncomfortable and reluctant to move about.</p>

*Table adapted from the "Sheep Production Handbook." 2006.*

### How many rams do you need?

You should have one mature ram for every 35 to 50 ewes. Ram lambs (7 to 12 months) can service 15 to 30 ewes.

## Reproduction

### Breeding

Female sheep (ewes) reach puberty between 5 and 12 months of age, depending on the breed and nutrition of the ewe, and should be at least 70% of their mature weight at breeding. Most sheep are seasonal breeders, reacting to shorter days as a cue for breeding. The presence of a ram stimulates the reproductive cycle (estrus). The typical peak time for breeding is the fall (October-November), and ewes come into heat every 16 to 17 days. Gestation is about 150 days.

Breeding and lambing should be planned based on many factors including the following.

- Market demands (What type and size of animal will you market and when?)
- Available forage
- Timing (Do you want to lamb in January or March?)
- Production system (Do your animals breed out of season; do you want multiple lamb crops in a year; are you lambing on pasture or in a barn?)
- Climate (Is shelter available?)



*Optimum lambing time varies depending on the production and marketing situation. Photo by Linda Coffey, NCAT.*

While the ram is often overlooked, he is the most important member of the flock. Your ram influences every lamb in your flock. Having a quality ram, with the traits you want, is important to building a productive flock.

Rams reach puberty between five and seven months, at approximately 50% of their mature weight. It is wise to have a breeding soundness exam (BSE) performed on your ram. A BSE can be conducted by your veterinarian or other trained professional. The exam consists of a physical evaluation of the ram (lameness, body condition, general health, scrotal circumference) and semen evaluation (sperm count, motility, and morphology). It is also important to observe rams for breeding behavior. A breeding soundness exam will not indicate libido. You can use a marking harness to assess breeding behavior and effectiveness. Exposure to high temperatures can cause a ram to be temporarily sterile (up to 10 weeks). Shade and shearing can help keep rams cool.

Males of breeding age are unpredictable and may be aggressive. Rams should never be trusted, even if they were hand raised. In fact, hand-raised rams can be more dangerous because they lack fear or respect for humans. Behaviors that were fine when they were small (butting, rubbing) can be dangerous in a full grown ram. Never turn your back on a ram. If you are raising rams, don't touch their heads, and don't try to make them pets.

### Lambing

In general, ewes will lamb with no assistance and with no problems. Good nutrition and plenty of exercise will prevent many birthing problems.

Lambing can be done in sheds or barns or on pasture. Pasture lambing reduces the need to invest in buildings and equipment and is more appropriate for low-input systems. Southern flocks will have less difficulty with inclement weather than those in colder climates. Disease occurrence may be lower with pasture lambing than with shed lambing because disease agents are not concentrated as they are in confinement. Disadvantages

of pasture lambing include greater risks of parasites and losses from bad weather and predators.

Optimum lambing time varies depending on the production and marketing situation. By timing lambs to be born around the same time as the spring flush of growth in the pasture, ewes can have adequate forage during their peak period of lactation. This will also cut down on the supplemental feed ewes need. However, some producers have noted that lambs born later in the spring do not grow as well as lambs born earlier, which may be due to parasites. Lambs born later are just starting to graze as parasite numbers on pasture are increasing. Earlier lambs have a chance to grow and develop their immune systems before they have the parasite pressure of spring and summer grazing. If lambing occurs early in the year (January to early March), ewes will need high quality hay and possibly other supplements to meet the needs of lactation. Evaluating your costs may help you decide on the best lambing season for your farm.

## Lamb management

It is crucial that newborn lambs receive colostrum (first milk) as soon as possible (ideally, in their first 12 hours). Monitor lambs to make sure they are nursing and have bonded with the ewe. It may be necessary to remove a lamb(s) from the ewe if she does not have enough milk for her lambs. Ewes should have enough milk for twins, but some ewes might not be able to raise triplets or quadruplets. Lambs that have had enough milk feel heavy when you lift them, with slightly rounded bellies. They will seem content after nursing and strong, lively, and playful. Lethargic lambs or crying lambs may be a sign they are not nursing or are not getting enough milk. Starvation is a leading cause of death in the first two days of a lamb's life.

It is important to monitor lambs for health issues such as coccidiosis and internal parasites. For information on castration and tail docking, see ATTRA's *Illustrated Guide to Sheep and Goat Production*. Growing lambs

need high quality forage. In a rotational grazing system, let weaned lambs graze a pasture first. This will ensure they are getting quality forage and also grazing pastures with lower parasite numbers.

## Health

Starting with healthy sheep and properly maintaining them with adequate nutrition and clean living conditions will prevent most health problems. In addition, vaccinations and low stress handling will assist in keeping a flock healthy. Observe your animals and respond quickly to any health problems — isolate animals at the first sign of illness. Indications of a sick sheep include lethargy, isolation from the flock, loss in body condition, abnormal manure, runny nose, and huddled posture. It is important to have a working relationship with a veterinarian. A veterinarian can help with preventative care and proper treatment of disease. To locate a veterinarian who works with sheep, contact the American Association of Small Ruminant Practitioners: (334) 517-1233, [www.aasrp.org](http://www.aasrp.org).

Even with proper management, sheep will sometimes have health problems. Keeping health records will help you to identify animals that have repeated health problems. Culling those animals will result in a stronger flock. The following is an overview of some common health problems that affect sheep.

## Internal parasites

For many sheep producers, especially those in humid climates, internal parasites will be the primary health concern. Animals with severe internal parasite loads will be unthrifty, won't gain weight, are often anemic, and may die. Due to overuse of dewormers and parasites' increasing anthelmintic resistance, management of internal parasites is a complex problem. Sheep producers must be knowledgeable about internal parasites, and they must have a plan to prevent and manage parasite infections. Because of the complex nature of internal parasites, managing them will take an integrated approach. A combination of treatment and management

### Related ATTRA Publications

Managing Internal Parasites in Small Ruminants

Tools for Managing Internal Parasites in Sheep and Goats: Copper Wire

Tools for Managing Internal Parasites in Sheep and Goats: Sericea Lespedeza

Integrated Parasite Management for Livestock

is necessary to control parasitism so that it will not cause economic loss to the producer.

Parasite management tools may include the following:

- Pasture management
  - \* Use pasture rotation with adequate rest periods.
  - \* Employ multi-species grazing.
  - \* Provide taller forages and browse.
  - \* Put susceptible animals (lambs) on pasture before mature animals.
- Animal selection
  - \* Use breeds and animals that show resistance to parasitism (pay special attention to rams).
  - \* Cull animals that are frequently “wormy.”
- Selective deworming (only treating animals that need it)
  - \* Use FAMACHA<sup>®</sup> to identify wormy animals. FAMACHA<sup>®</sup> is a system for classifying animals into categories based upon levels of anemia (a sign of *H. Contortus* infection).
  - \* Be alert to other physical signs of parasitism and deworm as needed.

- Strategic deworming
  - \* Deworm ewes at lambing time.
  - \* Treat lambs because they have little resistance.
  - \* Deworm all new animals.
- Effective use of dewormers
  - \* Use the Smart Drenching technique. ([www.scsrpc.org/SCSRPC/Files/Files/Misc/DRENSHIN.PDF](http://www.scsrpc.org/SCSRPC/Files/Files/Misc/DRENSHIN.PDF))
- Novel treatments
  - \* Treat animals with copper wire boluses.
  - \* Provide forages containing condensed tannins (*sericea lespedeza*).

For more information on managing internal parasites, see ATTRA’s *Managing Internal Parasites in Small Ruminants* and visit The Southern Consortium for Small Ruminant Parasite Control website: [www.scsrpc.org](http://www.scsrpc.org).

## Foot rot

Foot rot is a contagious disease caused by bacteria that affect the horny hoof tissue. Once foot rot is introduced into a flock, it is very difficult to eradicate. Foot rot is spread from an infected sheep to the ground and bedding, where it is picked up by uninfected sheep. Foot rot is characterized by limping animals and pockets of foul-smelling infection in the hoof. Other things can cause limping; have your veterinarian examine the animals if you are unsure of the cause of limping.

Foot rot can easily be prevented by not introducing it to your flock. Never buy a limping animal or one from a flock with any limping animals. Don’t purchase sheep from sale barns. Practice good biosecurity; isolate new purchases for 30 days and examine their feet during that time; wear boot covers when visiting other sheep producers and have them do the same. Cull animals with repeated foot rot problems.

Hoof trimming and foot baths are common treatments for foot rot. All affected hoof tissue should be trimmed away. Remember to disinfect the trimming tools between animals



Animals will pick up more parasite larvae when they graze forages shorter than four inches. Photo by Linda Coffey, NCAT

to prevent spreading the infection. Foot baths of zinc sulfate or copper sulfate solutions can be used to treat foot rot. For help with hoof trimming and foot bath solutions, contact your veterinarian. There is a foot rot vaccination that has shown some success in prevention and treatment, but it is not 100% effective.

## Scrapie

Scrapie is a fatal, degenerative disease affecting the central nervous system of sheep and goats. It is among a number of diseases classified as transmissible spongiform encephalopathies (TSE). Signs of scrapie include weight loss despite retention of appetite, itching and rubbing, loss of coordination, and death. In the U.S., scrapie has been diagnosed mostly in Suffolk sheep and their crosses.

The U.S. has had some form of a scrapie eradication or control program in place for many years. As part of the National Scrapie Eradication Program ([www.aphis.usda.gov/animal\\_health/animal\\_diseases/scrapie](http://www.aphis.usda.gov/animal_health/animal_diseases/scrapie)), all states require most sheep and goats to be officially identified on change of ownership. And, while many states have requirements identical to the USDA interstate requirements, other states have additional requirements regarding intrastate movement and/or interstate movement. Some states exempt certain classes of sheep and/or goats. For information on your state's scrapie identification requirements, see [www.eradicatescrapie.org/State%20ID%20Requirements.html](http://www.eradicatescrapie.org/State%20ID%20Requirements.html).

## OPP

Ovine progressive pneumonia (OPP) is a virus that generally affects only sheep over the age of two. OPP is spread through the ingestion of infected colostrum and milk. Signs of the disease are primarily seen in mature sheep. Early signs of OPP are weight loss while maintaining a normal appetite and intolerance to exercise. Other signs are labored breathing, hard udder, and lameness. OPP can be diagnosed through a blood test. There is no treatment for OPP. Animals testing positive should be culled from your flock. For more information, see [www.oppociety.org](http://www.oppociety.org).

## Contagious Ecthyma

Contagious ecthyma (commonly called sore-mouth or orf) is caused by a virus. Infected animals will develop sores and scabs on their lips and mouths and occasionally on the udders and teats. The virus can remain infectious in the scabs for long periods. Once an animal has been infected, it is generally immune to further infections. Because soremouth is a virus, antibiotics are ineffective; you have to let the virus run its course. This virus can be passed to humans; always wear gloves if you handle animals with soremouth. There is a vaccine, but if you have not had soremouth in your flock, it is better not to vaccinate because the vaccine contains a live virus. For more information, see [www.sheepandgoat.com/articles/soremouth.html](http://www.sheepandgoat.com/articles/soremouth.html).

## Caseous Lymphadenitis (CL)

Caseous lymphadenitis (CL) is caused by a bacteria that causes abscesses on the lymph nodes and internal organs. The bacteria are usually introduced through a wound or abrasion. The clinical signs of the disease are one or more abscesses that are often located just beneath the skin, usually around the jaw and neck. However, if organisms enter the bloodstream, abscesses may also develop in internal organs such as the lungs or liver. In this case, external abscesses may not be present, and the only noticeable symptom is a thin, debilitated animal. The abscesses contain a thick, yellow to white pus that has a soft, pasty consistency, much like toothpaste.

CL does not respond to antibiotics because antibiotics cannot penetrate inside the abscess. Abscesses can be surgically drained and flushed with an iodine solution. However, draining the abscess will increase risk of transmission of the organism to other animals if they are exposed to the pus. The discharge that is present in the abscess should be disposed of in such a way as to avoid contamination of the facilities and remaining animal population. In sheep, abscesses are usually not found until shearing. During shearing, the shearer may inadvertently nick the wall of an abscess. If this occurs, shearing should be stopped, and the clippers, blades and general

area should be disinfected as well as possible.

Currently, one company manufactures a vaccine for the prevention of CL. This vaccine is called Case-Bac®, and it is manufactured by Colorado Serum Company. A study published in the Journal of the American Veterinary Medical Association showed a significant reduction in the number of abscesses when sheep were vaccinated. (Washburn et al., 2009)

## Mastitis

Mastitis is an inflammation of the mammary gland and may result in reduced production and profitability. It is usually caused by the bacterium staphylococcus or streptococcus, but it can also be caused by other bacteria. Symptoms include pain, heat, redness, swelling, and a hard udder. Ewes will not always show physical symptoms of mastitis. A ewe with mastitis may not let her lambs nurse. Lambs that aren't growing and thriving may be an indication of mastitis in their dam. Streptococcus infections are responsive to antibiotics and are fairly easy to eradicate. Staphylococcus infections do not respond well to antibiotic treatment. Mastitis may also be the result of injury.

## Vaccinations

Vaccinations can be important to your flock's health plan. Simple vaccinations can prevent many diseases that affect sheep. The most common sheep vaccinations are those that protect against clostridial diseases. A CD-T vaccine protects against enterotoxemia caused by *Clostridium perfringens* types C and D and tetanus caused by *Clostridium tetani*.

There are many other vaccinations available. Contact your local veterinarian to discuss other vaccinations based on your flock's health and local disease problems.

## Record keeping

Record keeping is a vital part of your flock's health program. It is important to keep records of sick animals, treatments administered, and note milk and meat withdrawal times. Good records can help you choose animals to cull.

## Facilities

Sheep don't require extensive housing or facilities. You should provide shelter from cold, rainy weather and shade in the summer. Buildings used for shelter may be minimal, but they should be well-ventilated and clean. Barns and sheds are not the only options. There are portable shelters and moveable shades, and even old hog huts can be used as shelters for your animals.

There are many options for handling facilities. While there are many elaborate systems available, a simple gathering area and chute or alleyway is all that is needed for most small operations. Having a useable handling system makes tasks such as sorting, weighing, vaccinating, or FAMACHA® scoring much easier. A scale is an important piece of equipment because knowing the weight of your animals aids in marketing, tracking weight gains, and calculating proper medicine and deworming doses.

For more information on shelters, equipment, and fences, see ATTRA's *Illustrated Guide to Sheep and Goat Production*.

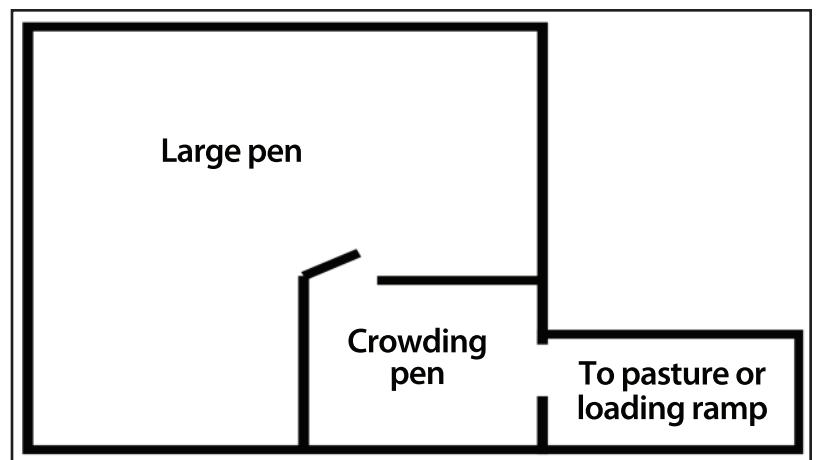

An example of a simple handling set-up. Diagram by Susan Schoenian, University of Maryland.



### Handling sheep

Sheep raised in close contact with people experience less stress when being handled.

Tips for proper handling:

- Be calm and patient
- Do not probe or force livestock.
- Move slowly and deliberately.
- Talk softly and in a low tone.
- To restrain sheep, hold them under the chin, with a halter, against a fence or gate, or straddling them.
- Be careful of horns and sudden movements.

List adapted from a presentation by Susan Schoenian, University of Maryland ([www.sheepandgoat.com](http://www.sheepandgoat.com)).

## Marketing

While there are many opportunities for marketing sheep and sheep products, there are also many limitations. Options may be limited by regulations, access to processing, or access to an adequate market. There are many more options than just taking your sheep to the sale barn. How you choose to market your animals will depend on many things, including personal preferences and market demands.

### Sale Barn

Taking sheep to a local auction is one of the most common methods used by producers. There are advantages to this method: it is quick, it requires little effort by the producer, and most auctions are bonded, which means you will be paid within 24 hours of sale. The biggest disadvantage is that you have no control over the price. There are a few things producers can do to get the best price for their animals at an auction.

- Do not just show up; contact the auction manager, describe your flock, and ask him when the best day to come to his auction would be. He should be helpful and show

interest in acquiring your business. If he is not, choose another auction.

- Ask if you can bring your animals the day before and if hay and water are available. Ideally, they will be presented earlier in the auction, but at the least will be acclimated to the environment and look nicer for the sale.
- Find out whether there are any auctions in your area that will allow you to set a floor price.
- Stay for the auction; don't just drop the animals off. An auction is a great place to make connections and find future customers. Talk to the buyers about what they are looking for, and tell them about your operation.
- Try not to restrict your marketing to auctions alone, because they can be very risky.

### Pooled sales

There are several ways to cooperate with other producers to sell large volumes of animals and receive a better price than at a traditional sale barn. A pooled sale is where you work with a buyer who wants a large volume (semi-trailer load) of animals. The buyer will tell you what type and size of animals he needs (e.g., 100-pound lambs). You can then work with other producers to complete his order and bring all of the animals to a central location. The benefit of this type of sale is you will usually know what the buyer will pay prior to selling the animals. If the price is not high enough to cover your costs, you can choose not to participate. It is very important to meet the criteria that the buyer sets. If he asks for 100-pound lambs and you bring 75-pound lambs, the buyer won't be happy, you won't receive the set price, and the buyer may not agree to work with you again. Pooled sales do take a great deal of organization, since you will have to find a buyer, determine the needs of the buyer, and coordinate with other producers.



There are many options for marketing sheep and sheep products. Photo by Susan Schoenian, University of Maryland.

## Packers, wholesalers, dealers and retailers

A meat packing business generally owns its own processing plant and buys animals to slaughter, process, and resell. A wholesaler buys animals, takes them to a slaughterhouse, and butchers them to sell to a variety of retailers. Retailers (restaurants, grocery stores) sell directly to the end customer. These people are known as “middlemen,” and they do the hard work for you, but you get a lower price for your product.

## Direct marketing

Direct marketing is when producers sell their products directly to their customers. This allows the producer to bypass the “middleman” and become a “price-maker” rather than a “price-taker.”

Direct marketing options may be limited by your location and the processing available. If there is not a processor nearby, direct marketing alone is not a viable option for your operation. Direct marketing takes a lot of time, effort, communication, and intensive management. Producers must be willing to wear several hats; along with their livestock management skills, they must become businessmen, marketing agents, and salesmen. If your customers are coming to your farm, your facilities must be presentable. Provide additional information about your facility,

why your lambs are different, what their living conditions are, how they are fed, and why the customer should buy from you. You could provide a handout with information or even samples of smoked or barbecued lamb. For additional direct marketing advice and ideas, see the Direct Marketing Lamb Management Guide at [www.kansasruralcenter.org/publications/DMLamb.pdf](http://www.kansasruralcenter.org/publications/DMLamb.pdf).

There are many options for selling directly to your customer:

- **On Farm:** If you are selling on farm, your facilities must be clean and presentable. Make sure your pastures are not run down and that all animals are healthy. Keep breeding stock separate from sale animals. You could offer a tour of your farm while explaining what sets it apart from others. If you have animals other than sheep, this is a good opportunity to market them and diversify your sales.
- **Live:** As with selling the whole/half lamb, selling the animal live is a good option. Many producers sell the live animal for \$1 per pound or more. Keep in mind that customers who buy a live animal do so to ensure that it is slaughtered according to their religious beliefs, and they may request a place to slaughter their animal on-site. Check state and local regulations to see whether this is permissible.
- **Whole/Half:** If you have customers who are willing to buy a whole or half lamb, this is the best option because you sell the lamb all at once and do not have to market the less-desirable cuts.
- **Cuts:** Selling cuts of lamb individually is the most time-consuming practice, but it is usually what customers want. You must have the animal processed, packaged, and labeled and have a place to store the meat. You need to determine the price of each cut, and consider making

value-added products from the remainder of the animal.

- **Farmers' markets:** Farmers' markets are great for marketing your product and meeting potential customers. However, they can be very time consuming, and you must know the regulations on bringing meat to the market. Some markets require the producer to furnish a generator and freezer if selling fresh or frozen meat, and some allow only processed meats. Regulations, fees, and licenses vary, so be sure to check with the market director and local health department.
- **Restaurants/Stores:** Restaurant and grocery store sales can be good, reliable sources of income, but these establishments are often very unforgiving. They require a consistent, high-quality, and lean product, often year-round. Be sure to have a good relationship with a quality processor if you sell directly to restaurants or stores.
- **Ethnic/Religious Groups:** Many ethnic and religious groups prefer lamb (and mutton) to other meats. If you live near an area with a diverse population, this may be a strong customer base. If you are targeting a specific group, it is important to know what type of animal they want and when. Preferences such as age, size, and sex of the animal can vary depending on the group and the holiday. For more information on marketing to ethnic and religious groups, see the following resources.

\* Producing and Selling Sheep to Ethnic/Religious Markets, [www.westernmaryland.umd.edu/ethnic-marketing.htm](http://www.westernmaryland.umd.edu/ethnic-marketing.htm)

\* Ethnic Holiday Calendar 2009-2013, [www.sheepandgoat.com/articles/ethniccalendar.html](http://www.sheepandgoat.com/articles/ethniccalendar.html)

\* Direct Marketing Lamb to Niche and Ethnic Markets, <http://web.extension.uiuc.edu/iidea/PDF/lambfactsheet.pdf>

Processing	
There are different levels of processing, and access to them will affect how you can market your animals.	
Federal or USDA Inspected Plants	Federal plants can process meat for nationwide sale.
State Inspected Plants	Only about half of the states have a State Inspection program. State inspected plants can process any meat, but it is stamped for sale only within that state.
Custom Exempt Plants	A custom plant processes for individual use. The meat must be stamped "not for sale."
On-farm slaughter (exempt from inspection)	Animals are processed by the owner for individual use (regulations vary by state).

- **Buyers Clubs:** With a buyers club, you will pre-sell your lamb, usually a whole or half animal. You will work with the processor to meet the customer's cut preferences. You will then deliver the cut and wrapped lamb to the customer. This set-up works well if you have customers who want lamb on a regular basis.
- **Internet Sales:** The Internet is both a vast source of information and a very useful tool that costs very little. Shipping meat can be complicated and expensive, and it is often not worth the trouble. However, many people don't realize that Internet advertising can increase local sales. Whether you have your own website, advertise on a local website, or just add your business to Internet directories, such as [www.localharvest.org](http://www.localharvest.org), web advertising can be very beneficial with little or no cost to the producer. The Internet can also be a means by which current customers can invite their friends to look into your product.

Before you begin marketing, consult your local and state authorities about the regulations governing the marketing of meat products. You may need USDA inspection, permits, or licenses. There might be requirements regarding sales tax, weight, measurement, sanitation, zoning, and right-of-way. All of these regulations vary depending on the type of product you want to market (fresh, frozen, processed) and where (interstate, intrastate) you want to market it.

## Sierra Farms, California, Mel and Mary Thompson

Mel Thompson and his wife, Mary, have been producing sheep in northern California for 12 years. Their family-owned operation, Sierra Farms, currently has about 350 polypay/white dorper cross ewes and 500 lambs. Both Mel and Mary have a passion for farming and have raised sheep since they were children. When they began Sierra Farms, they were selling their lambs in traditional auctions or directly to a processor. Recently, however, they have begun to find innovative ways to market their lambs directly to the public, “to avoid the middleman,” and have found other, surprising benefits in the process.

Mary has created a website, [www.lambeatersconnection.com](http://www.lambeatersconnection.com), that is a directory connecting lamb producers with consumers. The goal of Lamb Eaters Connection Directory is to provide the public with local connections to fine lamb through chefs, caterers, restaurants, wineries, producers, and retail outlets. Mary began the website in 2008, and it has picked up speed since, with people all across the country adding listings. Included in the directory are home dining recipes, buying and cooking tips, names of breeders, sources for wool fiber, and many sheep related products and activities. Mary always welcomes comments or questions about the directory.

In 2006, Mel, with a group of lamb producers, received a USDA Value-Added Producer Grant (VAPG) to develop a feasibility study and business plan for directly marketing lamb. The study and business plan identified a marketing niche that included regularly scheduled sales and deliveries to individuals in the San Francisco Bay area. After a year of ground work, sales have reached 25 to 30 lambs each month. Mel works with his processor, Superior Farms, to have the lamb processed, vacuum sealed, and boxed.

Mel spends up to four hours per day marketing, using e-mail and making phone calls. He has begun using a blog, [www.sierrafarmslamb.blogspot.com](http://www.sierrafarmslamb.blogspot.com), to improve information flow. His blog posts remind customers that “sustainability is a two-way street; you’re helping us, we’re helping you.” He highlights the benefits of local, pasture-raised lamb, champions direct food access and local economies and promotes source identification and lamb-husbandry education.

Mel and Mary have found direct marketing to be extremely satisfying, both for themselves and their customers. Mel has been surprised by the response from customers — their gratefulness for this direct marketing experience and for the quality of lamb they are now able to purchase.

“I come from a long line of farmers,” Mel says, “but I think I may be hearing for the first time in that history people thanking a farmer for what he is doing. It’s a stunning and humbling thing to hear.”

“I think the important message is that consumers are increasingly looking for ‘social attachment’ or definition in the common activities of their lives. The act of eating is being rediscovered or redefined, along with expectations of quality and welfare assurances. Direct marketing is the perfect opportunity to make this attachment, and a single producer should not minimize his or her individual capability to make it happen.”

By managing the farm the same way they always have (maximizing pasture efficiency by rotational grazing, reducing supplementation, providing a healthy livestock environment, and reducing stress) but changing their marketing plan, Mel and Mary are now selling high quality products to socially-conscious buyers and receiving a premium price, while furthering farm-to-plate education and awareness. Both producers and consumers are benefiting from this.

## Processing

There are three levels of meat inspection: federal, state, and uninspected or custom-slaughter plants. State inspected meat cannot be sold outside of that state, and uninspected meat must be for the owner’s use only and labeled “not for sale.” Federally inspected processing plants that are willing to take a small number of animals, or even keep your meat separate, are very hard to find. You might have to base your marketing on using state-inspected facilities or make arrangements with custom processors. A good option (if your customer wants an entire animal) is to sell the animal live, transport it to the butcher for your client, and have the client pick it up and pay processing fees. Check with your state department of agriculture for your state’s regulations on processing, selling, and on-farm slaughter. Call the USDA Food Safety and Inspection Service hotline at 1-800-535-4555 with any questions about federal regulations. The Niche Meat Processor Assistance Network ([www.nichemeat-processing.org](http://www.nichemeat-processing.org)) also offers information and resources about meat processing regulations and contacts for locating a processor.

## Labeling

There are laws that require your labels to be reviewed by state and federal authorities before they are used in advertising. If your product is a single meat product with no added ingredients, the labeling process should be fairly easy. The USDA Meat and Poultry Labeling Terms can be found at [www.fsis.usda.gov/PDF/Meat\\_and\\_Poultry\\_Labeling\\_Terms.pdf](http://www.fsis.usda.gov/PDF/Meat_and_Poultry_Labeling_Terms.pdf) or by calling the USDA Meat and Poultry Hotline, 1-888-674-6854.

## Records

No matter how you sell your animals, be sure to obtain a copy of an invoice for your farm records. This is particularly important if you are directly marketing your animals. You should create an invoice that includes the seller’s name, buyer’s name, number of animals (or pounds of meat), price per unit, total price, and date picked up or delivered. Whenever possible, have the buyer sign the invoice.

## Value-added products

There are many other products from sheep besides fresh or frozen meat that can provide additional income. The “trimmings” from meat can be used to make sausage, bratwurst, and jerky. Pet foods are also a growing market for lamb producers; you can market organ meat, ground lamb, bones, and other low-end cuts to pet food producers as high-quality, allergen-free ingredients.

Fiber can become a value-added product; you can sell your animals’ wool to make blankets, yarn, or clothing. Some breeds have hides that make beautiful rugs. If you are directly marketing from your farm, you could learn to make these products and sell them on your farm. You can also work with other businesses to get products made from your fiber.

## Grazing services

Another enterprise is to offer “grazing services” for forage management. Both parties benefit in this transaction. The producer gets paid to graze his or her animals on another’s property, and the customer gets vegetation managed and fertilized “naturally” by landscaping livestock. Of course, the producer usually provides transportation and a means of containing the animals, closely monitoring that they do not overgraze the land. For more information on grazing services, see *Target Grazing: A Natural Approach to Vegetation Management and Landscape Enhancement* ([www.cnr.uidaho.edu/lrx-grazing/Handbook.htm](http://www.cnr.uidaho.edu/lrx-grazing/Handbook.htm)) and *www.livestockforlandscapes.com*.

## Breeding stock

If you maintain high-quality, healthy animals, you may have the opportunity to sell breeding stock. These animals will fetch a higher price than animals sold for meat or at a sale barn. Breeding stock can be purebred or crossbred animals. Buyers who are interested in registered animals or show animals are probably more interested in purebred stock, and those who have a commercial flock may want to purchase quality crossbred animals. Keeping detailed production and health records is very important if



*Sheep can be used to graze power line right-of-ways. Photo by Susan Schoenian, University of Maryland.*

you are selling breeding stock. It may take some time and money to develop a market for your breeding stock. You must sell only healthy, productive animals as breeding stock, because you will have a reputation to uphold.

However you decide to market your animals, always be fair to your customers. A good reputation is the best way to grow your business. For more information on marketing sheep, see [www.sheepgoatmarketing.info](http://www.sheepgoatmarketing.info), [www.sheepandgoat.com/market.html](http://www.sheepandgoat.com/market.html), and *Marketing Out of the Mainstream* ([www.sheepusa.org/publications](http://www.sheepusa.org/publications)).

## Organic production

If you are interested in alternative production and marketing methods, you may want to consider organic. “Organic” means, among other things, raising crops or livestock in a way that builds the soil and enhances biodiversity and ecological balance. The term “organic” may not be used except under a production system that meets all the requirements of the National Organic Program Regulations, as defined in 7 CFR Part 205 (see [www.ams.usda.gov/AMSV1.0/nop](http://www.ams.usda.gov/AMSV1.0/nop)).

## Related ATTRA Publications

NCAT's Organic Livestock Workbook

Organic Certification Process

Organic Farm Certification and the National Organic Program

Organic Livestock Documentation Forms

Organic Standards for All Organic Operations

Organic Standards for Livestock Production

Organic System Plans: Livestock Production

Some producers choose to farm organically because they believe in the principles of organic agriculture, that organic systems build the health of soils, plants, animals, and people. Others do so because they want to sell products for a premium price to people who support organic principles and believe organic food is better for their health.

Depending on your production and marketing methods and customers, it may be to your advantage to raise and sell organic lamb or wool. This section highlights what is involved in producing sheep organically, and it will help you decide whether transitioning to organic is worthwhile for your operation.

What are the basic requirements of organic certification? (This is not a complete list.)

- Feed 100% certified organic feed (including pasture).
- Animals must graze on pasture at least 120 days per year, and animals must have a minimum of 30% dry matter intake from grazing pasture during the grazing season.
- Use of most synthetic medicines and/or hormones is prohibited (see the National List for materials and the purposes for which they may be used).
- Maintain organic stock under organic management from at least the last trimester before birth (i.e., ewes must be managed organically for more than 50 days before organic lambs are born).
- Meat must be processed in a certified organic facility and must not be irradiated.

For more information about the requirements for organic livestock production, see ATTRA's *Organic Standards for Livestock Production: Highlights of the USDA's National Organic Program Regulations* (summary of relevant verbatim standards) and NCAT's *Organic Livestock Workbook* (longer workbook format to guide the producer in looking at all components of a production system as they relate to organic standards and practices).

There are also important record-keeping requirements and certification tasks, including the following:

- An organic system (farm) plan approved by a certifying agent
- Up-to-date farm records for at least five years
- Annual inspection of the farm, including records and premises.

For some farms, current production practices are already very close to organic standards. Some farms keep extensive records. But for most, changes will be necessary in both production and record-keeping in order to comply with organic regulations. Will those changes be worth it? Consider the following questions:

- What price do you currently receive for your product?
- Is there local demand for organic products? (If not, you will need to develop a local market or develop one at a distance, and ship your product. Remember, market development costs time, energy, and money.)
- What price could you receive for organic lamb or wool? (Check the Internet for some idea of prices being asked.)
- What do you currently pay for hay or grain to supplement your animals?
- What would you have to pay for organic hay or grain? How dependable is the local supply? Can you offset the increase in the price for organic feed with sales of certified organic animals or products? (Remember, using homegrown feeds, especially pasture, will help greatly.)
- How important is organic certification to your customers? Is it sufficient for them to know you as the producer and understand that you use humane and sustainable practices, or do they need to see verification of organic standards?

Now for the next hurdle — if you are selling meat:

- Is there a certified organic processor in your area? This is necessary if you are selling organic meat.
- If there is not currently an organic processor, can you persuade a local processor to do the paperwork and follow the regulations?
- What extra processing costs will be charged for organic processing?

For information about organic meat processing, see [www.extension.org/pages/Certified\\_organic](http://www.extension.org/pages/Certified_organic) and [www.mosesorganic.org/attachments/broadcaster/livestock14.6meatprocess.html](http://www.mosesorganic.org/attachments/broadcaster/livestock14.6meatprocess.html).

If you are selling a live animal:

- Who is your buyer? It's best to have more than one option.
- What is the demand? How many animals can you sell a year, and is it a steady market?

If production costs will be feasible and the market is not a problem, then consider whether you can raise your animals under organic health management practices.

Organic health care is based on prevention of illness through good management.

- Animals adapted to the environment
- Appropriate vaccinations
- Good nutrition
- Low-stress handling
- Good sanitation
- Access to well-managed pasture, fresh air, and sunshine
- Low stocking rates
- Adequate shelter
- Good preventive care (regular foot trimming, for example)

All the above practices should be followed by producers whether they are certified organic or not, as they are simply good management practices. These practices will prevent many illnesses, assuming there is a closed flock. However, when illnesses do arise, you must

remember that conventional treatments such as antibiotics are not approved for organic production. You will have to find alternative treatments. If those are not effective, then you must use the conventional treatment for humane reasons, and remove the treated animal from organic status. In humid climates, sheep may have serious trouble with internal parasites. Internal parasites can be devastating to the health of the animal, causing loss of productivity and sometimes death. Under the National Organic Program regulations, use of chemical dewormers is restricted for breeding and milking stock (they may not be used on lactating ewes or ewes in the last trimester of pregnancy or on any animals routinely) and is prohibited for organic slaughter stock. If infection is severe, you should use the most effective treatment, including chemical dewormers if necessary. Animals treated with chemical dewormers are no longer certified organic and must be removed from the organic flock. Organic production is probably not a viable option for producers

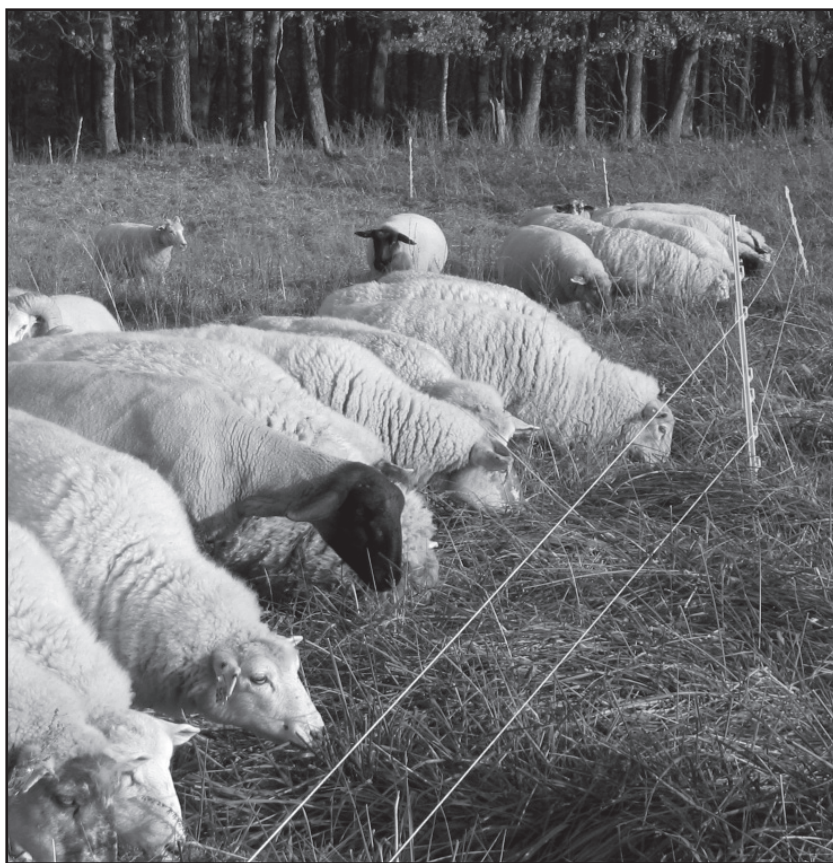

*Using forages helps to keep feed costs lower. Photo by Linda Coffey, NCAT.*

who raise sheep in climates that are extremely conducive to internal parasite infections.

See *Managing Internal Parasites in Sheep and Goats* for more information about this important topic. See also the *Organic Livestock Workbook* to get a fuller picture of what is involved in organic livestock production. ATTRA has many other publications that deal with organic certification as well.

For additional information on organic sheep production, see *Transitioning to Organic Sheep or Goat Meat Production* ([www.moses-organic.org/attachments/productioninfo/fstransgmeat.html](http://www.moses-organic.org/attachments/productioninfo/fstransgmeat.html)).

## Economics

One of the key questions to answer before starting an enterprise is, “Will it be profitable?” The answer is largely dependent on the management and the set of individual circumstances. Many sample budgets have been published, and they are useful in sorting out the various categories of expenses that must be considered.

There are some basic principles to keep in mind that will improve the chances for profit.

- Keep costs low — use forages, feed least-cost rations, maintain healthy animals.
- Pay attention to reproduction — ewes should breed and wean lambs; cull those that don’t.

- Cull animals that aren’t productive — those that don’t breed, don’t wean lambs, or don’t grow as they should.
- Have a consistent market for your product.

The table below illustrates the relationship between cost of production and reproductive performance. Ewe cost is the amount it costs to keep a ewe for a year. This will include feed, veterinary costs, fencing, and any other costs related to keeping your ewes. Lamb crop is the percentage of lambs weaned to ewes exposed to breeding.

Fifteen lambs weaned (marketed) / 10 ewes exposed to ram = 150% lamb crop

So, if it costs you \$50 to keep each ewe, and you had a 150% lamb crop, the lambs would need to bring \$0.33 a pound to break even. Clearly, the chances for profitability are far better if costs are kept low and ewes are productive and lambs survive. Note that market weight for this example is 100 pounds. Lighter lambs must bring higher prices.

The sample budget on the following page is included to assist the prospective producer in planning and in determining feasibility. Remember that costs are subjective and depend greatly on management and location. Your situation will not correspond exactly to anyone else’s.

For more information on economics, including several example budgets and budgets you can adjust to reflect your farm’s costs, see [www.sheepandgoat.com/economic.html](http://www.sheepandgoat.com/economic.html).

Break-even lamb price in dollars per pound				
Ewe cost (\$/head/yr)	% lamb crop			
	75%	100%	150%	200%
30	.40	.30	.20	.15
40	.53	.40	.27	.20
50	.67	.50	.33	.25
60	.80	.60	.40	.30

Assumed market weight is 100 lbs.



## Ewe flock, projected budget for lambs sold in 2010

Production description: Flock of 100 ewes and 3 rams with a 140% lamb crop raised; 22 ewe lambs retained as replacements. Purchase rams at \$300 each.

Estimated income/ewe (lamb crop: 140%)	Spring lambing	Your estimate
Lamb sales: 85 lbs. @ \$100/cwt. x 1.18*	\$100.30	\$
Cull ewe sales: 125 lbs. @ \$40/cwt. x 20%	\$10.30	\$

**ESTIMATED TOTAL INCOME/EWE** **\$110.30** **\$**

Estimated costs/ewe		
Operating costs		
Pasture (\$20/acre rental rate)	\$20.00	\$
Hay (100 lbs. @ \$70/T.)	\$3.50	\$
Grain (30 lbs. @ 7¢/lb.)	\$2.10	\$
Salt and minerals (10 lbs. @ 20¢/lb.)	\$2.00	\$
Dewormer (4 times/year)	\$2.00	\$
Vaccinations	\$0.42	\$
Insecticides	\$0.24	\$
Marketing and hauling	\$6.00	\$
Utilities and machinery costs	\$6.00	\$
Livestock facility and fence repairs	\$3.00	\$
Professional fees (legal, accounting, etc.)	\$0.50	\$
Miscellaneous	\$2.00	\$
Operating interest (1/2 of operating costs @ 7%)	\$1.67	\$
<b>TOTAL OPERATING COSTS (except labor)</b>	<b>\$49.43</b>	<b>\$</b>
Labor & management (3 hours @ \$11.50/hr.)	\$34.50	\$
<b>TOTAL OPERATING COSTS (including labor)</b>	<b>\$83.93</b>	<b>\$</b>
Ownership costs		
Depreciation and interest on livestock facilities	\$6.00	\$
Interest on ewe and ram	\$8.00	\$
Breeding stock purchases	\$5.00	\$
Insurance and taxes on capital items	\$2.00	\$
<b>TOTAL OWNERSHIP COSTS</b>	<b>\$21.00</b>	<b>\$</b>

**ESTIMATED TOTAL COSTS/EWE** **\$104.93** **\$**

Income over operating costs	\$26.37	\$
Income over total costs	\$5.37	\$

Budget prepared by Ron Plain, Extension Economist, University of Missouri-Columbia.

\*100 ewes x 140% lamb crop = 140 lambs; 140 lambs - 22 lambs retained as replacements = 118 lambs to sell.

## Conclusion

---

Sheep are generally easy to incorporate into a farming operation. They are small, relatively inexpensive, and integrate well with other livestock. Sheep do not share internal parasites with other livestock (except goats) and prefer vegetation different from what cattle, goats, and horses typically eat. Sheep are efficient because ewes can wean two or more offspring that weigh as much as or more than the ewe.

You must be careful when selecting sheep. Never buy breeding stock from a sale barn, and only buy healthy animals. Choose a breed that is best for your farm. Keep animals healthy by feeding them properly, giving them access to clean pasture, trimming their hooves as necessary, properly vaccinating, not overcrowding them, and de-worming only when necessary. Properly contain your animals with appropriate fencing, and protect them by providing an effective livestock guardian animal. Keep extensive records of vaccinations, de-worming, and all other medical treatments. To increase efficiency, cull animals that repeatedly have problems. This will avoid spread of disease, save money, and build a stronger, healthier flock.

There are many marketing options available. Sheep can be marketed at a sale barn, in pooled sales, or directly from your farm. Choose the market that is right for you and your operation. You can diversify your sales by offering breeding stock, grazing services, or value-added products. Always be honest and informed; if customers do not trust you, they will not return. You might consider organic production if you have a conducive environment. Remember to familiarize yourself with the regulations, make a plan, and speak to an expert when you begin any enterprise, particularly a certified organic one.

Never take the leap of beginning a business without knowing the economics. Create a business plan. Your venture should be realistically profitable on paper before you buy your first sheep. Keep records and analyze your budget regularly. Keep costs low by using forages and maintaining healthy animals. Have a plan for emergencies, and always be prepared to change your plan as your circumstances change.

## References

---

Committee on the Economic Development and Current Status of the Sheep Industry in the United States and the National Resource Council. 2008. Changes in the sheep industry in the United States; making the transition from tradition. National Academies Press. Washington, D.C. 364 p. Available free online at: [http://books.nap.edu/catalog.php?record\\_id=12245#toc](http://books.nap.edu/catalog.php?record_id=12245#toc)

Launchbaugh, K. and J. Walker. 2006. Targeted Grazing — a New Paradigm for Livestock Management, in *Targeted Grazing: A natural approach to vegetation management and landscape enhancement*. 2006. American Sheep Industry Association. Englewood, CO. 199 p. Available online at: [www.cnr.uidaho.edu/rx-grazing/Handbook.htm](http://www.cnr.uidaho.edu/rx-grazing/Handbook.htm)

National Agricultural Statistics Service (NASS). 2010. Sheep and Goats Inventory. <http://usda.mann-lib.cornell.edu/usda/nass/SheeGoat//2010s/2010/SheeGoat-01-29-2010.pdf>

Sheep Production Handbook. 1996. American Sheep Industry Association. Englewood, CO. 1176 p.

The National Research Council. 1985. The nutrient requirements of sheep. National Academic Press, Washington, D.C. 99 p. Available free online at: [http://books.nap.edu/catalog.php?record\\_id=614#toc](http://books.nap.edu/catalog.php?record_id=614#toc)

USDA. 2003. National Range and Pasture Handbook. NRCS-GLTI. <http://directives.sc.egov.usda.gov/viewDirective.aspx?hid=18937>

Walker, J.W. 1994. Multispecies grazing: The ecological advantage. *Sheep Research Journal (Special Issue)*:52-64.

Washburn, K.E., W.T. Bissett, V.R. Fajt, M.C. Libal, G.T. Fosgate, J.A. Miga and K.M. Rockey. 2009. Journal of the American Veterinary Medical Association Comparison of three treatment regimens for sheep and goats with caseous lymphadenitis. May 2009, Vol. 234, No. 9, p. 1162-1166.

## Further resources

---

For a more extensive list of resources, see ATTRA's *Small Ruminant Resource List*, [www.attra.org/attra-pub/small\\_ruminant\\_resources.html](http://www.attra.org/attra-pub/small_ruminant_resources.html)

## ATTRA Publications

An Illustrated Guide to Sheep and Goat Production

*This basic and heavily illustrated introduction to sheep and*

*goat production discusses animal selection, feeding, breeding and young stock, equipment and handling, and marketing.*

#### Small Ruminant Sustainability Checksheet

*This checksheet is designed to stimulate critical thinking when evaluating a farm that produces sheep or goats. The sustainability of a farm depends on many factors involving farm management, use of resources, and quality of life. The questions in the checksheet are intended to stimulate awareness rather than to rate management practices. Use this guide to define areas in your farm management that might be improved, as well as to identify areas of strength.*

#### Predator Control for Sustainable and Organic Livestock Production

*This publication focuses primarily on the control of coyotes and dogs, which are the main causes of livestock lost to predation, through management practices such as fencing and secure areas, and the use of guard animals*

#### Managing Internal Parasites in Sheep and Goats

*This publication discusses new techniques to manage parasites and to prolong the efficacy of dewormers. New management tools that remain under study are also discussed. A list of resources follows the narrative.*

#### Tools for Managing Internal Parasites in Small Ruminants: Copper Wire Particles

*The publication contains information on how to make boluses of copper wire oxide particles, and reports results of studies on the effectiveness of this treatment.*

#### Tools for Managing Internal Parasites in Small Ruminants: Sericea Lespedeza

*This publication discusses tools that can be used to manage internal parasites of sheep and goats that are becoming resistant to conventional dewormers. One such tool is the forage sericea lespedeza. The publication discusses how it can be used and presents the results of research on how it reduces parasites in small ruminants.*

#### Ruminant Nutrition for Graziers

*This publication provides managers with tools and references for considering biological and climatological variables in making decisions that ensure the ecological and economic viability of a grass-based ruminant livestock operation.*

#### Multispecies Grazing

*Brief overview of why multispecies grazing is beneficial, as well as considerations for management.*

## Books

Storey's Guide to Raising Sheep, by Paula Simmons and Carol Ekarius. 4th Edition. 2009. Storey Publishing, LLC., Pownal, VT. 400 p.

*This book is a very useful resource, covering many aspects of raising and marketing sheep and their products. It is enjoyable to read and helpful to beginners and experienced producers alike.*

More Sheep, More Grass, More Money, by Peter Schroedter. 1997. Ramshead Publishing Ltd. Moosehorn, Manitoba. p.112

*Personal experiences of the author, emphasizing the need to make a profit with the sheep enterprise and giving examples of how to cut costs and increase profits. Emphasis on grazing management. Very practical.*

Storey's Barn Guide to Sheep. Storey Publishing. 2006. Storey Publishing, LLC. Pownal, VT. 96 p.

*This spiral-bound book with large, heavy-duty pages is designed to accompany the farmer to the barn and is complete with step-by-step guides with several straightforward illustrations.*

Marketing Out of the Mainstream: A Producer's Guide to Direct Marketing of Lamb and Wool, by Tamra Kirkpatrick and James Bell. Sheep Industry Development Program. 57 p.

## Websites

Maryland Small Ruminant Page  
[www.sheepandgoat.com](http://www.sheepandgoat.com)

American Sheep Industry Association  
[www.sheepusa.org](http://www.sheepusa.org)

National Sheep Improvement Program  
[www.nsip.org](http://www.nsip.org)

Sheep and Goat Marketing Program  
[www.sheepgoatmarketing.info](http://www.sheepgoatmarketing.info)

Southern Consortium for Small Ruminant Parasite Control  
[www.scsrpc.org](http://www.scsrpc.org)

Lamb Eaters Connection  
[www.lambeatersconnection.com](http://www.lambeatersconnection.com)

**Sheep: Sustainable and Organic Production**

By Margo Hale, Linda Coffey  
NCAT Program Specialists

Ann Bartlett, Chelsey Ahrens  
NCAT Interns

© 2010 NCAT

Paul Williams, Editor  
Adrienne Herren, Production

This publication is available on the Web at:

[www.attra.ncat.org/attra-pub/sheep.html](http://www.attra.ncat.org/attra-pub/sheep.html)

or

[www.attra.ncat.org/attra-pub/PDF/sheep.pdf](http://www.attra.ncat.org/attra-pub/PDF/sheep.pdf)

IP102

Slot 90

Version 082410

By Margo Hale and  
Linda Coffey  
NCAT Agriculture  
Specialists  
©2006 NCAT

## Contents

Introduction.....	1
Getting Help .....	2
Getting Started .....	2
Labor .....	2
Marketing .....	3
Processing .....	3
Regulations.....	4
Budgeting .....	5
Production Notes.....	6
Selecting Stock.....	6
Nutrition .....	7
Milking.....	7
Production Records..	8
Health .....	8
Conclusion.....	10
References .....	12
Resources .....	12
Contacts.....	12
Web Sites .....	12
Associations .....	13
Periodicals/ Newsletters.....	13
Books/ Publications.....	13
Suppliers.....	14
Budgets.....	15

The sale of sheep milk or milk products is often more profitable than selling only lamb or wool. This publication explores the dairy sheep business and helps producers decide whether it is a viable option for their farms. Regulations governing the industry are discussed. Also addressed are production issues, animal health, stock selection, and nutrition issues surrounding dairy sheep. References and resources follow the narrative.



*Lacaune dairy sheep. Photo by Yves Berger, courtesy of University of Wisconsin Spooner Ag Research Center.*

## Introduction

A prospective dairy-sheep producer faces many potential challenges. First of all, any dairy operation requires a high degree of management skill. Raising dairy sheep involves two production systems—one for sheep and another for milk. People who haven't done either will need time to learn. Additionally, marketing sheep-milk products is a challenge. While the market for sheep-milk cheese is growing, it's still very small in this country and remains high-risk.

Production of sheep-milk cheese is a well-developed enterprise in parts of Europe. But sheep milk cheese production in the U.S. was unheard of until about 20 years ago, and is still rare. Some areas of the country lack markets for sheep milk. Still, some producers process the milk and market it directly to consumers.

Most sheep milk is made into cheese, or into products such as yogurt, ice cream, and soap. Prospective producers must invest

the time and effort to learn about product development and marketing.

Sheep exhibit a natural ability to efficiently process forage into meat, milk, and wool. To best take advantage of these traits, good grazing strategies must be developed—another area of special knowledge and management skills.

Finally, start-up costs can be high, and it may take several years to show a profit. Outside income or an extended line of credit may be required to subsidize the operation at first.

With all these concerns in mind, certain positives emerge in sheep dairying. A sheep dairy that delivers consistent products in a developed market can be far more profitable than an operation focused only on meat production. Sheep are also easier to handle and less expensive to maintain than cattle. And sheep milk can be frozen and stored for eventual sale as fluid milk or to make into cheese.

## Getting Help

As you plan a sheep dairy, explore several sources of information. The University of Wisconsin Cooperative Extension has published an excellent resource, *Principles of sheep dairying in North America*. This is a comprehensive and up-to-date publication, covering topics such as sheep milk and its uses, choosing a breed, nutrition, milking parlors and equipment, and the economics of raising dairy sheep. This publication can be downloaded from the Web at [http://cecommerce.uwex.edu/pdfs/A3767\\_Sheep\\_Dairying.pdf](http://cecommerce.uwex.edu/pdfs/A3767_Sheep_Dairying.pdf) or be purchased as a CD-ROM for \$20. To order, visit <http://learningstore.uwex.edu>.

Another great resource is a publication from the dairy supply company DeLaval, entitled *System Solutions for Dairy Sheep*. This book covers breeds, handling, feeding, health, and layouts of housing and milking parlors for dairy sheep. For a free copy, contact Tess Wagner at 816-891-1573 or [tess.wagner@delaval.com](mailto:tess.wagner@delaval.com).

The Great Lakes Dairy Sheep Symposium is held each year. The proceedings from these meetings are available at <http://www.ansci.wisc.edu/extension-new-copy/sheep/>. The proceedings are an excellent resource and include articles from researchers and producers on topics such as new research, new techniques, and practical tips to help producers.

*Practical Sheep Dairying*, by Olivia Mills, is another resource to explore. It is currently out of print from the U.S. publisher, but may be obtained through interlibrary loan or used book services. See the **Resources** section for additional publications, Web sites, and contacts.

In addition to exploring these written materials, a prospective producer needs to investigate the market, visit with other producers, and include family members in discussions. The remainder of this publication provides a brief overview of the dairy sheep business to encourage you and your family to consider carefully whether or not the business suits your family and farm goals.

At the end of each section are questions for your consideration.

## Getting Started

Before entering a commercial dairy sheep business, carefully consider the following elements:

- availability of labor
- marketing
- processing options
- regulations
- budgeting
- overall economic viability

### Have you considered:

- Am I a dairy person?
- Is my family interested in the enterprise?
- Where can I find more information?

## Labor

Labor is a major concern. Dairy sheep producers spend mornings and evenings—seven days a week, week after week—feeding, milking, and cleaning up. Do you enjoy sheep enough to meet these demands? Is your family supportive of this level of commitment? Many dairy producers face frustration and burnout after unsuccessful attempts to hire competent help. A family unwilling to help with the business may warrant a less demanding enterprise.

### Have you considered:

- Who will do the milking?
- Who will do the farming?
- Who will be in charge of flock health?
- Who will help you? How, and how much will you pay them?
- Who will do construction?
- Who will fix things that break?

### Related ATTRA Publications

Sustainable Sheep Production

Rotational Grazing

Meeting the Nutritional Needs of Ruminants on Pasture

Pastures: Sustainable Management

Integrated Parasite Management for Livestock

Grass-Based and Seasonal Dairying

## Marketing

If labor is available, the next concern is marketing. What product or products do you plan to sell? Is there an unmet demand for that product in your area? If so, what price can you realistically expect to receive? Can you make a profit at that price?

In the case of fluid milk, a prospective producer must first locate a reliable buyer. Judy Kapture, long-time producer and columnist for the *Dairy Goat Journal*, issues a strong warning to the farmer planning to start a goat dairy, which also applies to those planning to start a sheep dairy.

You are certainly wise to be cautious. I can tell far too many stories about people who used all their money to set up their farm as a goat dairy, and then never did sell any milk. Or their milk market fizzled out within a year... Get in touch with the (the buyer) to find out if they actually are planning to buy more milk. Learn the details—how much milk do they want from a farm, what do they pay for milk, is winter production a necessity, what do they charge for hauling, etc.

Then talk with some of the people who are shipping milk to them now. You want to find out if they feel the pay for the milk is good enough to make the goatkeeping effort worthwhile. (Remember that feed and other costs vary greatly and a “good milk price” in one area may be too low for another.) You may get some surprises when you ask this question... Be cautious about new startups. Sometimes they have a lot of enthusiasm but no idea how difficult it will be to market their milk or cheese or other product in the quantities they need... Are their patrons shipping milk to the buyer now? Talk to them, all of them. Are they getting paid? Is the buyer taking all the milk he promised he would?... How good is the market for what they are planning to sell? (Kapture, 2001)

Consider the same sorts of questions if you plan to process sheep milk into a product. Do you have the labor and expertise to run the dairy and make an additional product? Is there a market for the product in your area? Is the price you can charge for the product enough to make a profit?

Marketing may be one of your biggest obstacles. Because this is an industry in its infancy, there are few established markets.

The biggest demand for sheep cheese is on either coast. As with any other niche product, it takes a lot of effort to develop the market. Some producers are uncomfortable with marketing, while others find it exciting. You may want to read the ATTRA publications *Evaluating an Agricultural Enterprise*, *Adding Value to Farm Products*, and *Direct Marketing* for more information on this essential part of the business.

### Have you considered:

- Where and how will you market the milk?
- What is the market?
- Where is the market located?
- How much will you charge for the products? What does the competition charge?
- What kind of advertising will you need?
- What will you use to package? How will you label? What is your logo?

## Processing

Some producers choose not to deal with a milk buyer and work to increase farm profits by processing the milk themselves. Diverse products can offer more income and financial stability. These products might include fluid milk, cheese, yogurt, fudge, sheep-milk soap or lotions, sheepskins, or meat.

Cheese is a good alternative to selling milk, particularly if you like direct marketing. It is legal to use raw milk to make cheese if the product is aged at least 60 days before sale. (Dairy Practices Council, 1994) Fresh cheese must be made with pasteurized milk.

Cheese making classes are helpful. But experiment, practice, and sample regularly before trying to market farmstead cheese. You must abide by regulations (talk to your inspector about what is involved). Cheese making resources are discussed

### Related ATTRA Publications

Predator Control for Sustainable and Organic Livestock Production

Value-Added Dairy Options

Multi-Species Grazing

Dairy Farm Sustainability Checksheet

Small Ruminant Sustainability Checksheet

Small Ruminant Resource List

in *The Small Dairy Resource Book* (see **Resources**). Caprine Supply and Hoegger Supply are companies (see **Resources**) that offer several books about cheese making.

To locate the inspector with jurisdiction over your dairy and/or processing facility, go to the American Dairy Goat Association Web site, <http://adga.org/StartDairy.htm>, and scroll to your state. The contact information for the agency in your state is provided.

### Have you considered:

- The kinds of products you are planning?
- Is the market saturated with this type of product? If it is, why would yours be successful?
- How much will your products cost to produce?

**C**ontact your state inspector early in the process of setting up a commercial sheep dairy.

Edible products require a Grade A dairy, a commercial kitchen, and appropriate licensing (contact your state agency for more details). Soap making does not. Soap is non-perishable, easy to ship, and does not require much milk. These advantages make soap an appealing option for small farm enterprises.

Processing beyond bulk fluid milk creates extra demands on sheep farmers. The dairying must still be tended and somehow also the processing, packaging, marketing, delivery, and paperwork. While diversifying products may add stability (not all the eggs in one basket), each new product requires more equipment, labor, storage space, production knowledge and skill, and outlets for marketing. Unless a large labor force is available, too much diversification is unsustainable. “If you try to produce a whole line of products,” points out Tatiana Stanton of Cornell University, “it can make really big marketing demands on you if you are not going to sell them to the same buyer.”

For example, if you are a small producer and are going to sell fudge, soap, and cheese all to the same local food co-op or over the Web, that is one thing. You are going to have to do a lot more marketing if your cheese is going to cheese shops or restaurants, and your fudge and soap to gift shops. You may find in such a case that it is a terrible decision to expand your line. (Stanton, 2002)

The extra constraints of processing and marketing mean less time to spend with the animals. This is a trade-off to be considered. Will you provide the extra labor

required, or will you hire someone to process and market the products?

## Regulations

The U.S. Food and Drug Administration (FDA) drafted the Pasteurized Milk Ordinance (PMO) that states only pasteurized milk can be sold as Grade A. Enforcement of this ordinance is under the jurisdiction of state departments of health or agriculture (Zeng and Escobar, 1995). Local requirements may vary. Contact your state inspector early in the process of setting up a commercial sheep dairy. State inspectors may offer helpful suggestions and can assist you to plan and procure FDA-approved equipment. Many producers comment that state inspectors helped them avoid expensive mistakes. Locate the appropriate agency by finding your state on the list of contacts at <http://adga.org/StartDairy.htm>.

Scrapie is a fatal, degenerative disease that affects the central nervous system of sheep. It is of the class of diseases known as transmissible spongiform encephalopathies (TSEs). Other examples of TSEs include Bovine Spongiform Encephalopathy (BSE) or mad cow disease in cattle and Chronic Wasting Disease (CWD) in deer and elk.

There is no clear evidence that scrapie is transmissible to humans, but BSE has been linked to a rare but incurable neurological disease in humans. Therefore concern remains about scrapie’s potential to spread to humans. Negative public perception and the loss of export opportunities have encouraged efforts to eradicate scrapie from U.S. sheep.



Producers are required to participate in the Scrapie Eradication Program. Contact your state veterinarian for details, or go to the National Scrapie Education Initiative Web site, [www.eradicatescrapie.org](http://www.eradicatescrapie.org). First contact your state veterinarian to request a premises identification number. For additional information or for help in obtaining a premises ID number, call 866-USDA-TAG (toll-free). You will receive free ear tags with your premises ID printed on them. You must tag breeding animals over the age of 18 months before they leave your farm. In addition, an official Certificate of Veterinary Inspection (health certificate) issued by an accredited veterinarian must accompany breeding sheep that cross state lines (e.g., for show or for sale). (National Institute for Animal Agriculture, [www.eradicatescrapie.org/](http://www.eradicatescrapie.org/))

#### Have you considered:

- Do you know your inspector? Have you contacted your inspector?
- Can you comply with all regulations?

## Budgeting

Determine economic feasibility before starting a commercial sheep dairy. Many sample budgets are available, but each must be customized to fit an individual farm. Investigate local feed costs as well as the selling price of milk. Other key considerations include cost of building or converting barns, fences, and watering systems. Initial investment in livestock and in milking systems will be a large expense.

Bee Tolman, operator of the Tolman Sheep Dairy Farm, offered advice to prospective dairy farmers at the 8<sup>th</sup> Great Lakes Dairy Sheep Symposium in 2002.

Do a complete business plan before you do anything else. Include all financial statements in detail. Don't miss the details—they will be your undoing. And be conservative. I was advised by a goat dairy farmer (who has since folded) to add 30 percent to all budgeted costs. I didn't. I now know that if I had,

my plan would have been far more accurate. (Tolman, 2002)

As Tolman points out, talk to farmers who are currently in the business to ensure that your plan and your budget are realistic.

Begin your calculations by taking the following steps.

- *Research the market.* Is there a market? What is the current price for your product, whether fluid milk for processing, cheese, or soap? Is there a strong demand for your product?
- Estimate *production level*. How many ewes do you plan to milk? How productive will they be, on average? (Ask several commercial producers what their flock average is, and be sure to select ewes that can produce enough milk to be profitable.) Be realistic about production and marketing.
- Investigate *costs*. What does feed cost in your area? How much feed do you need to produce the planned quantity of milk? What about buildings, equipment, fencing, hay? You need to project marketing and hauling costs, health costs, utilities, supplies, breeding, and labor. Calculate initial cost of breeding stock, the cost to raise replacements, and build in an extra “cushion” for unexpected expenses. Remember, under-capitalization can doom even a good business plan.
- Consider *labor availability*. Plan for peak seasons such as lambing and breeding, and for processing and marketing.
- Create a *business plan*. Your lender will tell the figures needed; your local Cooperative Extension agent may be helpful. See also the **Resources** section for help with business plans.

The University of Wisconsin-Madison Center for Integrated Agriculture Systems has developed a budget for sheep dairies. It is an Excel program that allows

**D**etermine economic feasibility before starting a commercial sheep dairy.

you to enter specific numbers. The budget, along with detailed instructions for use, can be found at, [www.cias.wisc.edu/archives/2005/05/19/dairy\\_sheep\\_enterprise\\_budget/index.php](http://www.cias.wisc.edu/archives/2005/05/19/dairy_sheep_enterprise_budget/index.php).

#### Have you considered:

- A good return on your investment? Is it guaranteed?
- Have you written a business plan?
- Who will keep the records?
- Who will do the accounting?
- What income will you live on the first few years?
- Do you have a contingency plan for when things go wrong?

**T**he East Friesian is the most common breed of dairy sheep.

## Production Notes

### Selecting Stock

Just as a cow dairy would typically start with Holstein, Jersey, or another breed of dairy cattle, a sheep dairy should begin with a breed of dairy sheep. The East Friesian is the most common breed of dairy sheep. With the importation of half-Friesian rams and frozen semen, there is now percentage breeding stock available in the United States. If you already own a flock, the most economical way to begin a dairy

may be to breed ewes to an outstanding dairy ram, and hold back the best daughters to build a dairy flock.

East Friesian and Lacaune sheep are commonly found in dairy flocks in the U.S. Many producers use various crosses of these breeds with domestic American breeds. For more specific information about dairy sheep breeds, see *Principles of sheep dairying in North America* and *System Solutions for Dairy Sheep (Resources)*. Yves Berger also has an article, *Breeds of Sheep for Commercial Milk Production*, that can be found in the Proceedings of the 10<sup>th</sup> Great Lakes Dairy Sheep Symposium, [www.ansci.wisc.edu/extension-new-copy/sheep/Publications\\_and\\_Proceedings/res.html](http://www.ansci.wisc.edu/extension-new-copy/sheep/Publications_and_Proceedings/res.html).

Regardless of the breed, buying stock from a reputable breeder is essential. These people have usually spent several years selecting healthy ewes that milk well. Reputable breeders will produce breeding and health records, and can help you decide which animals are best for your situation.

#### Have you considered:

- What kind of ewes do you need?
- How many do you need?
- Where will you get your stock?
- Can you visit a reputable breeder and purchase stock?



Friesian sheep. From [www.ansi.okstate.edu/breeds/sheep/friesianmilk](http://www.ansi.okstate.edu/breeds/sheep/friesianmilk).



Lacaune sheep. From <http://sheepdairying.com/breeds>.

## Nutrition

Feeding your flock is not simple. Nutritional requirements vary depending on size, age, and stage of sheep production. As ruminants, sheep health and productivity depends on proper function of their complex stomach systems. The rumen is “healthiest” when sheep eat good quality forages, such as vegetative pasture. To get the best milk production from sheep, provide high quality forages. This can be achieved by grazing sheep on appropriate pastures or by feeding hay or silage. For more information about pastures and rotational grazing, see the ATTRA publications *Sustainable Pasture Management*, *Rotational Grazing*, *Paddock Design, Fencing, and Water Systems for Controlled Grazing*, and *Matching Livestock Needs and Forage Resources*. Also check with your local Extension and NRCS agents for information about forage plants that do well in your area.

Concentrates (grain) are often fed to milking dairy ewes to supplement forages and better meet the ewes’ nutritional needs. Careful consideration is necessary when feeding concentrates. To properly meet the nutritional needs of your animals, forages should be tested and the amount of supplement determined based on the quality of the forages available and the feedstuffs used.

Feed a half a pound of supplement per ewe per day for ewes on pasture, recommends Bruce Clement, of the University of New Hampshire Cooperative Extension. (Clement, 2002) His study examined levels of supplement for dairy ewes and dairy goats. The study found no difference in milk yield, milk composition, or animal condition score among ewes fed a half a pound of supplement per day and those fed 1.5 pounds of supplement per day.

The study also found that milk yield and milk composition lowered when 2.5 pounds of supplement per day was fed. The study concluded that dairy sheep on well-managed pastures lactating in the three pounds per day range need no more than a half a pound per ewe per day concentrate

supplementation. (Clement, 2002) The article, including the formula for the concentrate, is available by downloading the proceedings from the 8<sup>th</sup> Great Lakes Dairy Sheep Symposium, 2002, at [www.uwex.edu/ces/animalscience/sheep/Publications\\_and\\_Proceedings/symposium%20PDF/Great%20Lakes2002%20symposium.pdf](http://www.uwex.edu/ces/animalscience/sheep/Publications_and_Proceedings/symposium%20PDF/Great%20Lakes2002%20symposium.pdf) (see page 66).

The best feeding regimen for your animals is found through experience and experimentation with your flock and farm. Regardless of what you feed your ewes, access to clean water is always necessary. Lactating ewes require approximately three gallons of water per head per day. This is the highest water requirement of any class of sheep. (Thomas, n.d.)

## Milking

Sheep milk production is usually seasonal, with lactation varying from three to eight months, depending on the breed. (Thomas, n.d.) Milk production per lactation period also varies. It can be as little as 100 pounds per lactation for domestic ewes, or as much as 1,100 pounds per lactation for dairy breeds. Crosses between domestic and specialized dairy breeds produce anywhere from 250 to 650 pounds of milk per lactation. (Thomas, n.d.)

Ewes can be milked by hand or by machine. Hand milking is only practical for small flocks. Bucket milking is a popular option in the U.S. There is also the parlor system with a pipeline going into a bulk tank. *Principles of sheep dairying in North America* and *System Solutions for Dairy Sheep* discuss the many types of milking set-ups and the necessary equipment. There are also many articles about various parlors and methods of milking in the Proceedings of the Great Lakes Dairy Sheep Symposium (see **Resources**).

### Have you considered:

- Can you graze your animals year-round?
- If not, where will you get hay?
- Will you feed a supplement?
- Can you formulate a ration? Do you know someone who does?

Sanitary practices are critical, whether hand milking or machine milking. A sanitary environment is vital to the health of your ewes and the safety of the milk. Sanitation requires time and money, but it is time and money well spent. It is cheaper to prevent disease and contamination than to treat it.

A good reference for producers considering a commercial dairy is *Small Ruminant Guidelines* from the Dairy Practices Council. These *Guidelines* include a wealth of technical information about the details of setting up a milking parlor, producing quality milk and farmstead cheese, proper handling of wastewater, and much more. The *Guidelines* are sold separately or as a set; the set costs about \$70.00, plus shipping and handling, and is assembled in a binder for easy storage and reference. For more about this resource, see [www.dairypc.org](http://www.dairypc.org), or call 732-203-1194. For a commercial dairy operation, this is an invaluable tool.

**K**eepproduction, health, and financial records in order to maintain an efficient operation.

#### Have you considered:

- How many ewes are you going to milk?
- What type of system/set-up are you going to use?
- How are you going to get the necessary equipment?
- Do you know the requirements you must follow to meet regulations?

### Production Records

Accurate records are essential to any good business, including a sheep dairy. Keep production, health, and financial records in order to maintain an efficient operation.

Production records (i.e., how much milk a ewe yields, length of lactation, etc.) help a producer identify the most productive animals. Records also identify animals not pulling their weight. As you consider a purchase, individual production records and those of its relatives offer the best assurance that you have selected a productive animal.

When examining production records, keep in mind that production is naturally much lower during the first lactation. Examine the records for overall production in pounds, length of lactation, and butterfat and protein percentages (if those are important to your operation). Bear in mind that your own management will be a major factor in the ewe's production on your farm; production records only verify that a ewe has the genetic potential to produce that quantity of milk.

It is also important to keep records of when ewes are bred, when they are due to lamb, the date and type of vaccinations, and the occurrence and specifics of any health problems. Records help you manage your flock and remain the best tool to identify unproductive animals. Elimination of unproductive animals improves the sustainability of your farm.

#### Have you considered:

- The types of records you will keep?
- How you will keep them—by hand, computer, type of software, etc.?
- How will you process the information the records provide?
- Who will keep and review records?

### Health

Healthy animals are essential to a productive operation. Acquiring healthy stock and keeping records are ways to maintain a healthy and productive flock. Health problems will arise in any flock, however. In these instances, work with a veterinarian. Find one who knows (or is willing to learn) about small ruminants and who seems compatible with you and with your management style. You may locate a small ruminant veterinarian by contacting the Association of Small Ruminant Practitioners at [www.aasrp.org](http://www.aasrp.org). (See the **Resources** section for full contact information for AASRP.)

## Reduce mastitis by observing the following rules

- Detect infected animals early; follow up with either a treatment or culling.
- Wash hands frequently during milking. Milkers should wear latex gloves to decrease the possibility of spreading bacteria from one udder to the other.
- Shut off the vacuum line when removing the teat cups to avoid possible infected milk droplets reaching the teat opening of the next ewe.
- Use correct vacuum level and pulsation.
- Do not-over milk; it can cause trauma to the teat and increase susceptibility to infection.
- Clean the milking machine thoroughly.
- Clean air lines thoroughly.
- Change teat cup liners and milk lines periodically.
- Provide abundant fresh bedding for ewes in confinement.
- Clean the water delivery system.
- Conduct a post dipping program.

(Berger et al., 2004)

This publication provides discussion about a few health concerns of particular concern to dairy sheep producers. Additional pertinent health topics are discussed in ATTRA's *Sustainable Sheep Production* and *Goats: Sustainable Production Overview*. (Goats and sheep share many of the same health problems, including internal parasites.)

### Mastitis

Mastitis is an inflammation of the mammary gland and may result in reduced production and profitability. It is usually caused by the bacterium *staphylococcus* or *streptococcus*, but it can also be caused by other bacteria or by improper milking machine operation. Symptoms include pain, heat, redness, swelling, and a hard udder. Ewes will not always show physical symptoms of mastitis. A decrease in milk production and an increase in somatic cell counts are good indicators of mastitis. Milk samples can be cultured to determine the organism causing mastitis. *Streptococcus* infections are responsive to antibiotics and are fairly easy to eradicate. *Staphylococcus* infections do not respond well to antibiotic treatment.

Other causes of mastitis may include injury, malnutrition, or a contaminated or malfunctioning milking system. The first line of defense against mastitis is healthy teat skin. The cause of teat injury must be quickly identified and eliminated. Fluctuations in the milking vacuum and improperly designed or improperly functioning milking equipment must be investigated. Mastitis is also linked to diets deficient in vitamins A and E, selenium, and copper. (Pugh, 2002)

### Ovine Progressive Pneumonia (OPP)

Ovine progressive pneumonia, a chronic progressive pneumonia, is one of the most economically damaging diseases affecting sheep in North America. (Pugh, 2002) Pneumonia causes losses from sick animals, reduced production, and decreased sales. Signs of OPP include listlessness, emaciation, and difficulty breathing. Nasal discharge and coughing may also be seen. (Pugh, 2002) A vaccine is not available, so the only prevention is to keep animals with OPP out of your flock. This is

**O**vine progressive pneumonia, a chronic progressive pneumonia, is one of the most economically damaging diseases affecting sheep in North America. (Pugh, 2002)

accomplished through a blood test (ELISA), which can be conducted at a diagnostic lab prior to purchase. (Pugh, 2002)

## Internal Parasites

The control of internal parasites is a major concern for small ruminant producers, especially in humid regions. Control of these parasites is becoming increasingly difficult due to parasite resistance to treatments. Not only are dewormers less effective, but in many cases milk cannot be used during treatment due to drug residues. Therefore, learn to control parasites in your dairy business without relying on chemical dewormers.

Internal parasites are especially a problem in warm, wet climates and in settings where animals are grazed. Control of internal parasites can be nearly impossible where animals graze close to the ground on densely stocked pastures. Therefore, good pasture management (to avoid overgrazing) is critical to the health and productivity of your flock. In addition, several new techniques are aimed at controlling internal parasites without a complete dependence on commercial dewormers. These techniques include Smart Drenching and FAMACHA®. For more information on these and other techniques, visit the Southern Consortium for Small Ruminant Parasite Control Web site at [www.scsrpc.org](http://www.scsrpc.org). Be sure to consult with your veterinarian on this issue and on other health problems.

**I**f you can answer all or most of the questions presented, then you are well on your way to starting a successful sheep dairy.

### Have you considered:

- Do you have a veterinarian willing to work with you?
- Does your veterinarian have experience with sheep, or a willingness to learn about sheep?
- Do you have the knowledge to handle minor health concerns?

## Conclusion

The decision to start a sheep dairy is not an easy one. You probably will not become rich, but if you like sheep, have the markets and an understanding of them, and have the time to build a business, this can be a rewarding enterprise.

There is much more to learn about dairy sheep production, and the **Resources** section will help you to find more information. Your best sources of information are other farmers; talk to as many as you can, and learn from their experiences.

Have you considered the questions posed to you in this publication? If you can answer all or most of the questions presented, then you are well on your way to starting a successful sheep dairy.

### Acknowledgments

Many of the "Have you considered?..." questions were taken from the following.

Berger, Y. 2000. As a producer, should I consider sheep dairying? Sheep! Magazine. Vol. 21, No. 7, p. 4.

Kapture, J. 2001. Dairy operation requires ingenuity, perspiration, and more.... Sheep! Magazine. Vol. 21, No. 1, p. 12-15.

## Northland Sheep Dairy, New York By Karl North Pros and Cons of Milking Sheep

It should no longer need arguing that the most sustainable way to make milk is from grass. In some ways sheep are well suited to this sort of dairy farming. They both graze and spread manure more evenly than cows. Milking parlor and other handling machinery is economical because of their small size. All of ours is farm-built. A lactation of less than six months mirrors the grass season length in this [New York] climate, making seasonal dairying a natural. We time lambing for the beginning of grass in May; the lactation ends in early fall, and the flock finishes stockpiled pasture by the end of December.

Sheep milk, mild and unpretentious as mammary products go, nonetheless possesses qualities that become obvious in the processing. The yoghurt is thicker and smoother than cow or goat varieties, without additives. Cheeses do not need the extra butter fat of double and triple creme to come out rich and smooth. Thick milk and fine fat globules are an advantage in fudge-making too. Cooking down, a mix of half maple syrup and half sheep milk becomes a velvety confection.

Now for the disadvantages. Although sheep milk has about twice the solids of cow or goat milk (less useless water to transport all over the country), this hardly compensates for the low yield per milking ewe. Dairy sheep breeds can average three quarts a day or more over a five-month lactation, but like high production Holstein cattle, they force the farm into a high input mode in order to serve their special feed, shelter, and medical needs. We began with ordinary meat sheep—all that were available at the time. After 12 years of genetic selection both for a rustic, pasture-based life and for milk yield, the latter has doubled, but still averages only 1.6 quarts per ewe per day, and that only at the peak of their lactation. The upside of this equation is our success in maintaining our goal for an extremely low input operation. We are currently experimenting with various degrees of cross-breeding with the East Friesian, a dairy sheep of long pedigree in Northern Europe. Our goal is to discover what percentage of Friesian will add to milk yield without upsetting our low input system.

The second main disadvantage of sheep, whether for milk or meat, is the damage internal parasites can do to the health and growth of lambs. Here as elsewhere in farming there is a management solution to replace the chemical quick fix. But it takes a level of organization and development of the forage acreage of the farm that we have attained only in the last two years.

First the main forage fields of the farm must be fenced, supplied with water, cleared of trees and rocks to permit haying, and all must produce a quality of forage suitable for either hay or pasture, and for empty, dry stock or lactating ewes and growing lambs. Then a three-year rotation can be devised that always puts the weaned lambs on parasite-free pasture, by grazing them on fields used only for hay the year before. The main forage fields are divided into three sections, and the rotation proceeds as a given field is used for hay, then weaned lambs, then ewes (with lambs until weaned). Plans for the future are to add enough animal units of another hardy pasture species, like a few Highland cattle, along with our team of Haflinger draft horses, to balance the dairy ewe and lamb flocks, and provide the annual alternation of stock that we need for sustainable pest control in the sheep.

Lastly, although the sheep dairy industry in the United States has barely begun, there are already signs that wholesaling sheep milk may be dogged by the same profitability problems that have plagued cow dairies: forcing unwanted expansion, the use of high production (but also high maintenance) dairy breeds, debt, and a downward spiral of quality of life for the whole farm ecosystem (people, animals, plants, and soil).

To avoid this we planned for on-farm artisanal quality cheese-making and direct marketing of most of our products in a local farmers market. It was an easy decision, for when we started farming in New York we had just come from years of homesteading in France, where just this sort of small, vertically integrated dairy farm, and weekly local farmers' markets as well, are old traditions. Still, the sale of cheese, lamb, yarn, and tanned skins from a base flock of only 50 ewes barely provides a livable income, and then only because we enjoy considerable self-sufficiency in food (vegetables, meat, and dairy), energy (solar, wood heat, and draft horses), and of course fertilizer.

A younger couple (we are pushing 60) could operate the farm with 100 ewes and bring in a net cash income of close to \$20,000 without a great deal more capital investment. But the quality of life is excellent; we are free of much of the cost/price squeeze and resultant debt that is destroying family-scale dairy farming, and we enjoy the diversity of work: milking, processing, marketing, haying and logging mostly with draft horses, sheep and horse husbandry, composting and spreading, sheep dog training, gardening, and building and repairing simple structures and equipment with simple tools. Work gives way to semi-vacation when the grass season ends.

Visit [www.northlandsheepdairy.com](http://www.northlandsheepdairy.com) or e-mail Karl North at [northsheep@juno.com](mailto:northsheep@juno.com) for more information about his operation.

## References

- Berger, Y., P. Billon, F. Bocquier, G. Caja, A. Cannas, B. McKusick, P. Marnet, and D. Thomas. 2004. Principles of sheep dairying in North America. University of Wisconsin-Extension, Madison, WI. 151 p.
- Clement, B. 2002. Supplemental Feeding of Dairy Sheep and Goats on Intensively Managed Pastures. *In: Proceedings of the 8th Great Lakes Dairy Sheep Symposium.* Cornell University, Ithaca, NY. p. 66-77.
- Dairy Practices Council. 1994. Guidelines for Production and Regulation of Quality Dairy Goat Milk. Publication DPC 59. Dairy Practices Council. Keyport, NJ. 17 p.
- Kapture, J. 2001. Ask Judy. Dairy Goat Journal. Vol. 79, No. 1. p. 17.
- Pugh, D.G. 2002. Sheep and Goat Medicine. W.B. Saunders Company. Philadelphia, PA. 468 p.
- Stanton, T. Extension Associate, Department of Animal Science, Cornell University. 2002. Personal communication.
- Thomas, D. Dairy Sheep Basics for Beginners. *In: Proceedings of the Great Lakes Dairy Sheep Symposium.* Cornell University, Ithaca, NY. p. 70-77.  
[www.uwex.edu/ces/animalscience/sheep/Publications\\_and\\_Proceedings/Pdf/Dairy/Management/Dairy%20sheep%20basics%20for%20beginners.pdf](http://www.uwex.edu/ces/animalscience/sheep/Publications_and_Proceedings/Pdf/Dairy/Management/Dairy%20sheep%20basics%20for%20beginners.pdf)
- Tolman, B. 2002. Introduction to Dairy Sheep Farming—Getting Started. *In: Proceedings of the 8th Great Lakes Dairy Sheep Symposium.* Cornell University, Ithaca, NY. p. 2.
- Zeng, S., and E.N. Escobar. 1995. Grade A Dairy Goat Farm Requirements. Langston University. 8 p.  
[www.luresext.edu/goats/library/fact\\_sheets/d04.htm](http://www.luresext.edu/goats/library/fact_sheets/d04.htm)
- 1675 Observatory Drive  
University of Wisconsin  
Madison, WI 53706  
608-263-4306  
[dlthomas@wisc.edu](mailto:dlthomas@wisc.edu)  
*Faculty member at the University of Wisconsin and a valuable contact who has a lot of knowledge about sheep dairying, dairy breeds, and the cooperative in Wisconsin.*
- Yves Berger, PhD  
Spooner Agricultural Research Station  
W6646 Highway 70  
Spooner, WI 54801-2335  
715-635-3735  
715-635-6741 FAX  
[yvberger@wisc.edu](mailto:yvberger@wisc.edu)  
*Faculty member at the University of Wisconsin and a valuable contact who has a lot of knowledge about sheep dairying, dairy breeds, and the cooperative in Wisconsin.*
- Vicki Dunaway  
Hometown Creamery Revival Project  
P.O. Box 186  
Willis, VA 24380  
540-789-7877  
[ladybug@swva.net](mailto:ladybug@swva.net)  
[www.smalldairy.com](http://www.smalldairy.com)  
*Vicki Dunaway manages this project. It produces CreamLine and Home Dairy News. Dunaway has also published The Small Dairy Resource Book (see **Books**).*
- Carol Delaney  
Small Ruminant Dairy Project  
UVM Center for Sustainable Agriculture  
63 Carrigan Drive  
Burlington, VT 05405  
802-656-0915  
[Carol.Delaney@uvm.edu](mailto:Carol.Delaney@uvm.edu)  
<http://www.uvm.edu/~susagctr/>  
*Carol Delaney is the Small Ruminant Dairy Specialist at the Vermont Small Ruminant Dairy Project.*

## Resources

### Contacts

Dave Thomas, PhD  
Animal Science Building, Room 438

### Web Sites

University of Wisconsin-Extension Sheep  
Department

<http://www.ansci.wisc.edu/Extension-New%20copy/sheep/index.html>



### **Wisconsin Sheep Dairy Cooperative**

[www.sheepmilk.biz](http://www.sheepmilk.biz)

### **Small Ruminant Dairy Project**

[www.uvm.edu/~susagctr/?Page=srdp.html&SM=archivemenu.html](http://www.uvm.edu/~susagctr/?Page=srdp.html&SM=archivemenu.html)

### **The Hometown Creamery Revival**

[www.smalldairy.com](http://www.smalldairy.com)

### **Spooner Agricultural Research Station- Sheep Dairy**

[cals.wisc.edu/ars/spooner/sheep.html](http://cals.wisc.edu/ars/spooner/sheep.html)  
[www.sheepmilk.biz/spooner.htm](http://www.sheepmilk.biz/spooner.htm)

### **Southern Consortium for Small Ruminant Parasite Control**

[www.scsrpc.org](http://www.scsrpc.org)

### **National Scrapie Education Initiative**

[www.eradicatescrapie.org/](http://www.eradicatescrapie.org/)

## **Associations**

### **American Sheep Industry Association**

9785 Maroon Circle, Suite 360  
Centennial, CO 80112  
303-771-3500  
303-771-8200 FAX  
[www.sheepusa.org](http://www.sheepusa.org)

### **Dairy Sheep Association of North America**

[www.dsana.org](http://www.dsana.org)

### **American Cheese Society**

304 West Liberty St., Suite 201  
Louisville, KY 40202  
502-583-3783  
502-589-3602 FAX  
[acs@hqtrs.com](mailto:acs@hqtrs.com)  
[www.cheesesociety.org](http://www.cheesesociety.org)

### **American Association of Small Ruminant Practitioners (AASRP)**

1910 Lyda Avenue, Suite 200  
Bowling Green, KY 42104  
270-793-0781  
[www.aasrp.org](http://www.aasrp.org)

## **Periodicals/Newsletters**

### **sheep! Magazine**

145 Industrial Drive  
Withee, WI 54498  
[www.sheepmagazine.com](http://www.sheepmagazine.com)

*Subscription is \$21 per year.*

### **Home Dairy News**

P.O. Box 186-W  
Willis, VA 24380  
540-789-7877 Phone/FAX 24 hours a day  
[www.smalldairy.com/pubs.html](http://www.smalldairy.com/pubs.html)  
*Subscription is \$20 per year.*

### **CreamLine**

P.O. Box 186-W  
Willis, VA 24380  
540-789-7877 Phone/FAX 24 hours a day  
[www.smalldairy.com/pubs.html](http://www.smalldairy.com/pubs.html)  
*Subscription is \$25 per year.*

### **Small Ruminant Dairy Newsletter**

Small Ruminant Dairy Project  
Carol Delaney  
UVM Center for Sustainable Agriculture  
63 Carrigan Drive  
Burlington, VT 05405  
[Carol.Delaney@uvm.edu](mailto:Carol.Delaney@uvm.edu) [www.uvm.edu/~susagctr/  
?Page=srdp.html&SM=archivemenu.html](http://www.uvm.edu/~susagctr/?Page=srdp.html&SM=archivemenu.html)

## **Books/Publications**

### **Principles of sheep dairying in North America**

Berger, Y., P. Billon, F. Bocquier, G. Caja, A. Cannas, B. McKusick, P. Marnet, and D. Thomas. 2004. University of Wisconsin-Extension, Madison, WI. 151 p.

*Cost is \$20 for a CD version of the publication.*

*Order from:*

Cooperative Extension Publishing  
877-WIS-PUBS (947-7827)  
<http://learningstore.uwex.edu/Default.aspx>

### **System Solutions for Dairy Sheep**

Alfa-Laval. 1981. Alfa-Laval AB, Tumba, Sweden. 141 p.

*No charge.*

*Order from:*

Tess Wagner  
DeLaval  
816-891-1573  
[tess.wagner@delaval.com](mailto:tess.wagner@delaval.com)

### **Proceedings of the Great Lakes Dairy Sheep**

**Symposium** [www.ansci.wisc.edu/  
extension-new%20copy/sheep/  
Publications\\_and\\_Proceedings/res.html](http://www.ansci.wisc.edu/extension-new%20copy/sheep/Publications_and_Proceedings/res.html)

*Copies of the 1<sup>st</sup> through 3<sup>rd</sup> Proceedings can be purchased from:*

Wisconsin Sheep Breeders Cooperative  
7811 Consolidated School Road  
Edgerton, WI 53534  
608-868-2505  
[www.wisbc.com](http://www.wisbc.com)

*Copies of the 4<sup>th</sup> through 7<sup>th</sup> Proceedings can be purchased from:*

Yves Berger  
Spooner Agricultural Research Station  
W6646 Highway 70  
Spooner, WI 54801-2335  
715-635-3735  
715-635-6741 FAX  
[yberger@wisc.edu](mailto:yberger@wisc.edu)

### **Practical Sheep Dairying**

Mills, O. 1989. Thorsens, Wellingborough, England. 224 p. Out of print.

### **Small Ruminant Guidelines**

[www.dairypc.org](http://www.dairypc.org)

*Dairy Practices Council.  
Cost is \$70 for complete set.  
Order from:*

732-203-1194  
[www.dairypc.org](http://www.dairypc.org)

### **The Small Dairy Resource Book**

Dunaway, V. 2002. Hometown Creamery Revival. 56 p. Out of print.

*Can be viewed on-line at  
[www.sare.org/publications/dairyresource.htm](http://www.sare.org/publications/dairyresource.htm).*

### **Building a Sustainable Business: A Guide to Developing a Business Plan for Farms and Rural Businesses**

DiGiacomo, G., R. King, and D. Nordquist. 2003. Minnesota Institute for Sustainable Agriculture, Saint Paul, MN, and the Sustainable Agriculture Network, Beltsville, MD. 280 p.

*Available for \$14.00 + \$3.95 S/H by calling  
800-909-6472 or e-mailing  
[misamail@umn.edu](mailto:misamail@umn.edu).*

*For further ordering instructions or to view the publication, visit <http://www.misa.umn.edu/vd/bizplan.html>.*

### **The Legal Guide for Direct Farm Marketing**

Hamilton, N. 1999. Drake University, Des Moines, IA. 240 p.

*\$23.00, including shipping.  
Order from:*

Karla Westberg  
Agricultural Law Center  
2507 University Ave.  
Des Moines, IA 50311  
515-271-2947  
[Karla.westberg@drake.edu](mailto:Karla.westberg@drake.edu)

*For more information, visit <http://wsare.usu.edu/pub/index.cfm?sub=mkt&details&id=30>.*

### **Home Cheese Making: Recipes for 75 Homemade Cheeses**

Carroll, R. 2002. Storey Books. Pownal, VT. 288 p.

*Cost \$16.95.  
Order from:*

Storey Publishing, LLC  
800-441-5700 (toll-free)  
[www.storey.com](http://www.storey.com)

### **Cheesemaking Made Easy**

Carroll, R., and R. Carroll. 1995. Storey Communication. Pownal, VT. 144 p.

## **Suppliers**

### **Caprine Supply**

P.O. Box Y  
DeSoto, KS 66018  
913-585-1191  
800-646-7736 (toll-free)  
913-585-1140 FAX  
[www.caprinesupply.com](http://www.caprinesupply.com)

### **Hoegger Supply Company**

P.O. Box 331  
Fayetteville, GA 30214  
770-461-6926  
800-221-4628 (toll-free)  
770-461-7334 FAX  
[www.hoeggergoatsupply.com](http://www.hoeggergoatsupply.com)

### **DeLaval, Inc.**

11100 N. Congress Ave.  
Kansas City, MO 64153-1296  
816-891-7700  
[www.delaval.com](http://www.delaval.com)

**Westfalia Surge**

1880 Country Farm Drive  
Naperville, IL 60563  
877-973-2479  
630-369-9875 FAX  
*www.westfaliasurge.com*

**The Schlueter Company**

3410 Bell Street  
Janesville, WI 53545  
608-755-5444  
608-755-5440 FAX

**The Coburn Company**

P.O. Box 147  
Whitewater, WI 53190  
800-776-7042 (toll-free)  
*www.coburnco.com*

***Budgets*****University of Wisconsin-Madison Center for  
Integrated Agriculture Systems**

*www.cias.wisc.edu/archives/2005/05/19/  
dairy\_sheep\_enterprise\_budget/index.php*

**Small Ruminant Dairy Project**

Contact Carol Delaney at 802-656-0915.

For additional resources, please refer to ATTRA's  
*Small Ruminant Resource List*.

**Dairy Sheep**

By Margo Hale and Linda Coffey  
NCAT Agriculture Specialists

©2006 NCAT

Paul Driscoll, Editor  
Cynthia Arnold, Production

This publication is available on the Web at:  
[www.attra.ncat.org/attra-pub/dairysheep.html](http://www.attra.ncat.org/attra-pub/dairysheep.html)  
and  
[www.attra.ncat.org/attra-pub/PDF/dairysheep.pdf](http://www.attra.ncat.org/attra-pub/PDF/dairysheep.pdf)

IP288  
Slot 82  
Version 051206



# ANIMAL SCIENCE FACTS

PUBLICATION NUMBER

ANS 00-603MG

## Extension Animal Husbandry

Department of Animal Science

### BREEDS AND PRODUCTION TRAITS OF MEAT GOATS

**Jean-Marie Luginbuhl**  
*Extension Meat Goat Specialist*

#### Meat Goat Breeds

Goats of any breed or crossbreed are eventually slaughtered for human consumption. With the exception of the South African Boer goat imported via New Zealand in early 1993, there are no true meat goat breeds in the U.S. However, there are a few breeds that stand out as more specialized for meat production. These breeds are the Spanish, Myotonic, Nubian and Pygmy goats.

A clear indication that the meat goat industry is expanding is shown by the 13% increase in the number of goats sold through NC auction markets, from 27,874 in 1995 to 31,503 in 1996. By the end of 1997 and 1998, 34,160 and 35,116 goats had been sold through NC weekly auction markets, respectively, additional increases of 8.4 and 3%, followed by a 3.9% decrease in 1999, as more goats were sold through marketing channels not controlled by the NCDA. A few years ago, prices of Boer breeding stock decreased enough to become affordable to small producers. Consequently, crossbred animals having Boer genetics are now being sold for meat at auction markets or under private treaty sales and buyers and consumers already have recognized the superior carcasses of those animals.

*Reviewed by: Dale C. Miller and Roger L. McCraw, Department of Animal Science, North Carolina State University*

#### Boer

The Boer goat of South Africa owes its name to the Dutch word "boer" meaning farmer. The origin of Boer goats is vague and probably rooted in indigenous goats kept by Hottentot and migrating Bantu tribes, with a possible infusion of Indian and European bloodlines. The present-day improved Boer goat emerged in the 20th century when South African farmers started breeding for a meat type goat with good conformation, high growth rate and fertility, short white hair and red markings on the head and neck. The South African Boer Goat Breeders' Association was founded in 1959 to establish breed standards for the emerging breed. Since 1970 the Boer goat has been incorporated into the South African National Mutton Sheep and Goat Performance and Progeny Testing Program, which makes the Boer goat the only known goat breed routinely involved in performance and progeny tests for meat production. There are approximately 5,000,000 Boer goats in Africa, of which 1,600,000 are of the improved type.

New Zealand and Australian companies have imported the Boer goat into their respective countries for improving their own meat goat industries. In April of 1993, the quarantine restrictions for the New Zealand Boer goats expired and animals became available for importation into the U.S. The Australian Boer goats were released in October 1995. In June 1993, the North American Boer Goat Association was founded, breed standards were established and registry of animals was begun.

Distributed in furtherance of the Acts of Congress of May 8 and June 30, 1914. Employment and program opportunities are offered to all people regardless of race, color, national origin, sex, age, or handicap. North Carolina State University, North Carolina A&T State University, U.S. Department of Agriculture, and local governments cooperating.



**North Carolina  
Cooperative Extension Service**

NORTH CAROLINA STATE UNIVERSITY  
COLLEGE OF AGRICULTURE & LIFE SCIENCES

According to New Zealand researchers, the plane of nutrition plays a greater role than the light/dark cycle for Boer goats to breed out of season.

<i>Live weight (lbs)</i>	<u>Male</u>		<u>Female</u>	
	<i>Avg</i>	<i>Max</i>	<i>Avg</i>	<i>Max</i>
Yearlings	100	180	80	135
Adults	250	290	140	200

### **Spanish**

The Spanish goat came originally from Spain via Mexico to the USA. It is now a meat type goat found primarily on or around the Edwards Plateau of Central Texas. The Spanish goat has the ability to breed out of season and is an excellent range animal because of its small udder and teats. In addition, Spanish goats are usually characterized as being very hardy, able to survive and thrive under adverse agroclimatic conditions with only limited management inputs. Within the general group of "Spanish goats" there are those that are purely Spanish, whereas others represent an amalgam of all genotypes introduced to the area. There have been obvious infusions of dairy and Angora blood in many Spanish herds but no organized attempt has ever been made to use them for milk or mohair production. The terms "wood" (Florida), "brush" or "briar" (North Carolina, South Carolina), "hill" (Virginia), and "scrub" (Midwest, Pennsylvania) goat tend to be used in the Southeast and elsewhere to refer to Spanish goats. Until recently, these goats were kept mainly for clearing brush and other undesirable plant species from pasture lands. In recent years, the escalating demand for goat meat and the expanding interest in cashmere production have focused attention on the Spanish goat. Current estimates of the Spanish goat population is around 500,000 head. Several Spanish goat producers in Texas have been intensively selecting for increased meat production for the past several years. From information obtained from these producers, these "selected" Spanish goats appear to greatly outperform the ordinary Spanish goat used primarily for pasture maintenance.

### **Myotonic**

The Myotonic goat has several aliases including "Tennessee Stiff-Leg", "Tennessee Wooden-leg", "Nervous Goat", "Fall-Down Goat" and "Fainting Goat". The Myotonic goat is a very meaty and muscular animal. This goat breeds out of season, and in many herds it is usual for does to kid twice a

year. Number of kids varies from single to four.

The Myotonic goat suffers from a recessive trait called myotonia. When frightened, it experiences extreme muscle stiffness causing extension of hind limbs and neck. In this startled state, if unbalanced, the animal will topple over like a statue or will stand immobile until the attack, usually lasting only 10-20 seconds, passes. According to a Texas neurologist, this type of involuntary isometric muscle contraction could build a more tender muscle than a muscle developed by strenuous use.

Little is known about the earliest history of this breed except that in the early 1880's a man appeared in Marshall County, Tennessee with a cow, three does and a buck of a unique strain. These four goats suffered from myotonic spells and were purchased by a Dr. Mayberry who propagated the breed. The population of Myotonic goats is informally estimated to be around 3,000 to 5,000 head, with herds found primarily in Tennessee and Texas.

### **Nubian**

The Nubian goat, also called Anglo-Nubian, is considered a dual-purpose goat breed used for milk and meat production. This breed was developed in England and is a composite of dairy goat breeds from India, Europe and Africa. Brought into the USA at the beginning of this century, the Nubian has become the most popular US dairy goat breed, with over 100,000 registered breeding stock.

### **Pygmy**

The Pygmy is a dwarf, heavily muscled and short legged goat from Nigeria in West Africa. The Pygmy found its way to the Caribbean and North America as a by-product of the slave trade in the 18th century. In West Africa, the Pygmy is used almost exclusively for meat production. The pygmy is well adapted to humid climates, it usually breeds all year and twinning is frequent. In the USA, the Pygmy has so far been raised mainly as a pet and as a show animal, and over 30,000 animals are currently registered with the National Pygmy Goat Association.

The Piedmont Pygmy Goat club has three sanctioned shows a year: the NC State Fair Pygmy Goat Show and two other shows held at the Agricultural Barn in Greensboro in spring and fall.

### **Kiko**

The Kiko was developed over two decades of

intensive selection from New Zealand feral goatstock. The Kiko is thought to be a vigorous, hardy, large frame and early maturing animal that doesn't need pampering.

### **Production Traits**

Four key traits to be considered for genetic improvement in goats used primarily for meat production are the following: 1) adaptability to environmental and production conditions, 2) reproductive rate, 3) growth rate and 4) carcass characteristics. Of these four production traits, only carcass characteristics are not readily measurable on the farm.

#### ***Adaptability***

This trait is the most important of all the production traits. The profitability of any meat goat enterprise may be greatly diminished if an animal's ability to survive and reproduce is impaired by the production environment. The goat has proven to be perhaps the most adaptable of all the domesticated livestock. Indeed, the goat survives worldwide in a wide range of environmental conditions. However, when taken out of one environment and placed into another, domesticated livestock of any species may not always realize its production potential. Therefore, we might expect Spanish goats to perform differently in the Carolinas and Virginia than they do on the arid Edwards Plateau of Texas. Similarly, Boer goats might perform differently in South Africa than they do in North America. In addition, different degrees of adaptability exist between breeds. For example, we might expect Spanish goats to be inherently better adapted to extensive, browsing conditions than Tennessee Stiff-Leg goats.

Adaptability is a lowly heritable trait because natural selection has already reduced the genetic variability. Therefore, adaptability will respond slowly to selection.

#### ***Reproductive Rate***

In animals kept primarily for meat production, reproductive rate is the single most important factor contributing to the efficiency of production. Reproductive traits of interest in a meat goat enterprise are conception rate, kidding rate, and ability to breed out of season.

In general, goats have a high reproductive rate with conception rate not being a problem. Several studies

have demonstrated that although twins and triplets have lower birth and weaning weights and slower growth rates, they produce more total weight of kid per doe per year. Therefore, prolificacy, defined as the number of kids born per doe, is an important reproduction trait. Goats that have evolved in the temperate zones of the world tend to be seasonal breeders, with females coming into estrus in the fall and anestrus occurring in late spring. This breeding pattern does not always coincide with the optimal marketing period of weaned kids. On the other hand, goats from tropical regions are non-seasonal breeders and kid all year-round. Therefore, incorporating this trait of non-seasonality into a meat goat enterprise would be advantageous.

#### ***Growth Rate***

Growth rate can be effectively divided into two periods: pre-weaning average daily gain and post-weaning average daily gain. A high pre-weaning average daily gain not only reflects the genetic potential of the growing animal, but also the mothering ability of the doe. In some production systems, kids are sold at weaning and therefore pre-weaning average daily gain is an important production trait to consider. In other production systems kids are sold as yearlings or as older animals and post-weaning average daily gain becomes an important production factor.

#### ***Carcass Characteristics***

Carcass characteristics of interest are dressing percentage, anatomical distribution of muscle and the ratios of lean:fat:bone. Generally, the dressing percentage of goats is around 45%. As an animal grows, the percentage of fat in the carcass tends to increase, the percentage of bone tends to decrease, whereas the percentage of lean muscle stays about the same. The portions of the carcass with the largest muscle mass are the leg and shoulder. However, percentage wise, these portions tend to decrease as the animal grows.

### **Summary**

With the exception of the Boer goat, meat goat breeds are lacking in some aspects of performance or have not yet been tested in our production systems. Using a set of scales and good record keeping, meat goat producers can readily collect the information needed for the selection of animals possessing the economically important traits described while keeping carcass characteristics in mind.

# Animal Resources

## Additional Resources

### Books

#### **Small- Scale Livestock Farming: A Grass Based Approach for Health, Sustainability, and Profit**

Ekarius, Carol. 1999. Storey Books, Pownal, VT. 217 p.  
Not specific to any species of livestock; contains farmer profiles and quite a bit of holistic planning and economic information. Very complete in treatment of rotational grazing.

#### **Storey's Guide to Raising Sheep: Fourth Edition**

Simmons, Paula and Carol Ekarius. 4th Edition. 2009. Storey Publishing, LLC., Pownal, VT. 400 p.  
This book is a very useful resource covering many aspects of raising and marketing sheep and their products. Enjoyable to read and helpful to both beginners and experienced producers.

**Meat Goats: Their History, Management, and Diseases** Mitcham, Stephanie and Allison Mitcham. 2000. Crane Creek Publications, Sumner, IA. 264 p.

A well-written combination of the authors' personal experiences raising goats, veterinary knowledge (Stephanie Mitcham is a DVM), and a compilation of information from other experts in the field. Includes information about handling systems (hard to find elsewhere).

**Storey's Guide to Raising Dairy Goats** (Revised and updated; originally called Raising Milk Goats the Modern Way) Belanger, Jerry. 2001. Storey Books, Pownal, VT. 288 p.

Very good general information for producers of dairy goats.

#### **Angora Goats the Northern Way: Fourth Edition**

Drummond, Susan Black. 4th edition. 1993. Storey Lonesome Farm, Freeport, MI. 239 p.

#### **Raising Goats for Milk and Meat: Third Edition**

Sinn, Rosalee. 3rd Edition. 2008. Heifer International, Little Rock, AR. 218 p.

Written for producers with limited resources, this is a very practical book, much expanded over the previous version; don't miss the chapter on health,

which includes emphasis on prevention. Educators will appreciate the format of this book, in which the 10 chapters are presented as learning guides and lessons. This is an ideal course for educators working with groups and for self-study.

**Raising Meat Goats for Profit** Bowman, Gail. 1999. Bowman Communications, Inc., Twin Falls, ID. 256 p.

This "how-to" book is a wonderful resource for goat breeders. It includes information about the meat breeds, how to get started with meat goat production, feed ration tables, kidding and raising kids, how to sell your goats, and information on health and diseases, as well as recipes.

**Storey's Guide to Raising Meat Goats** Sayer, Maggie. 2007. Storey Publishing, LLC., Pownal, VT. 320 p.

**Meat Goat Production Handbook** Gipson, T.A., R.C. Merkel, and S. Hart. 2008. American Institute for Goat Research, Langston, OK. 418 p.

Comprehensive and highly useful guide to meat goat production and marketing. See content online at [www.luresext.edu/goats/training/qa.html](http://www.luresext.edu/goats/training/qa.html) (Web-based Training and Certification Program for Meat Goat Producers). This spiral-bound book is a handy reference.

To acquire a copy, write to:

MGPH

Langston University

Box 730

Langston, OK 73050

or access the order form at [www.luresext.edu/goats/handbookorderform.pdf](http://www.luresext.edu/goats/handbookorderform.pdf). Current cost is \$50, which includes shipping and handling in the U.S.

### Web sites

**ATTRA—National Sustainable Agriculture Information Service**

[www.attra.ncat.org](http://www.attra.ncat.org)

**Maryland Small Ruminant Page**

[www.sheepandgoat.com](http://www.sheepandgoat.com)



**Web-based Training and Certification Program for Meat Goat Producers**

[www.luresext.edu/goats/training/qa.html](http://www.luresext.edu/goats/training/qa.html)

**Langston University–E (Kika) de la Garza American Institute for Goat Research**

[www2.luresext.edu/goats/index.htm](http://www2.luresext.edu/goats/index.htm)

**North Carolina State University – Extension Animal Husbandry** (see Meat Goat)

[www.cals.ncsu.edu/an\\_sci/extension/animal/eahmain.html](http://www.cals.ncsu.edu/an_sci/extension/animal/eahmain.html)

**American Sheep Industry Association**

[www.sheepusa.org](http://www.sheepusa.org)

**Hair Sheep Research and Information**

[www.sheepandgoat.com/HairSheepWorkshop/index.html](http://www.sheepandgoat.com/HairSheepWorkshop/index.html)

**National Sheep Improvement Program**

[www.nsip.org](http://www.nsip.org)

**Sheep Extension Program, Farm Flock Sheep Production Handbook, Montana State University**

<http://animalrangeextension.montana.edu/articles/sheep/handbook/handbook-TOC.htm>

**University of Wisconsin Sheep Extension**

[www.ansci.wisc.edu/Extension-New%20copy/sheep/index.html](http://www.ansci.wisc.edu/Extension-New%20copy/sheep/index.html)

**American Dairy Goat Association**

[www.adga.org](http://www.adga.org)

# Forage Utilization



In this section:

- Pasture, Rangeland and Grazing Management
- Ruminant Nutrition for Graziers
- Multispecies Grazing
- Rotational Grazing
- Grazing Systems Planning Guide
- Extending Grazing and Reducing Stored Feed Needs
- Use of Goats as Biological Agents for the Control of Unwanted Vegetation
- Meat Goats in Land and Forage Management

(continued)

# Forage Utilization (continued)



- Forage Needs for Meat Goats and Sheep
- Forage Needs and Grazing Management for Meat Goats in the Humid Southeast
- Forage Based Dairy Goat Management
- Additional Resources

By Lee Rinehart  
 NCAT Program  
 Specialist  
 © 2006 NCAT  
 Updated Nov. 2008

## Contents

Introduction.....	1
Temperate pasture .....	2
Rangeland.....	2
Managing soil and forage resources.....	3
Intake, sward density and grazing period.....	5
Legumes and soil fertility.....	5
Stocking rate.....	5
Ecological weed management in pastures .....	6
Multispecies grazing .....	7
Pasture renovation and establishment.....	8
Rotational grazing and paddock size .....	10
Overgrazing .....	12
Plant species and systems for extending the grazing season .....	12
Prescribed grazing on rangeland .....	13
Developing a grazing management plan on rangeland.....	14
Managing for drought ..	15
Plant toxicity .....	16
Summary.....	18
References .....	18
Further Resources .....	19

ATTRA—National Sustainable Agriculture Information Service is managed by the National Center for Appropriate Technology (NCAT) and is funded under a grant from the United States Department of Agriculture's Rural Business-Cooperative Service. Visit the NCAT Web site ([www.ncat.org/sarc\\_current.php](http://www.ncat.org/sarc_current.php)) for more information on our sustainable agriculture projects.



In a time of high-cost inputs, pasture-based livestock production systems can naturally maintain soil and plant integrity while growing healthy ruminants. This publication profiles the general types of pastures and rangelands and offers information about management and expected yields. Weed management strategies are also discussed and tips are offered to rehabilitate depleted land. Issues in grazing management, such as paddock development, plant selection, drought and plant toxicosis, are also discussed. Resources and references are also presented.



*Photo by Lee Rinehart, NCAT*

*Sheep on native range in southwestern Montana.*

## Introduction

Pasture is the basis of any livestock operation that purports to be truly sustainable. It is especially important as the livestock sector continues to experience extraordinarily high fuel and other input costs. Pasture-based production systems offer farmers and ranchers the ability to let the ruminant's environment and immune system work together, thereby gaining an acceptable level of production while naturally maintaining the integrity of the ecological connections between ruminants, the soil and the pasture plants. Ruminants on pasture experience fewer health problems due partially to reduced stress, whereas ruminants that are subjected to confinement have their digestive physiology running at top speed

with the use of high-grain rations. Grain-fed ruminants typically require treatment for maladies such as acidosis, mastitis and respiratory disease due to the fact that their immune systems have been seriously compromised. A singular focus on productivity often causes more problems than a systems approach. A well-planned and managed pasture-based operation can maintain reasonable production, reduce input costs and achieve a positive economic return, given a well-conceived marketing plan.

Much of the grazing land in the United States can be used more efficiently for livestock grazing. For instance, U.S. Department of Agriculture Agricultural Research Service scientists have utilized wheat pasture and old world bluestem perennial

grass pastures, such as those that occupy large sections in the Southern Great Plains, and stocked them with double the number of cattle they normally would when using intensively managed grazing techniques. Even on the arid rangelands of the western United States, increased stock density coupled with decreased time on a pasture has been successful in increasing livestock enterprise productivity while improving the condition of the rangeland.

The ecological processes that occur on temperate pastures and on arid rangelands are basically the same, but occur much slower on rangelands due mainly to temperature and moisture differences. The following section is an attempt to clarify the nature of both types of pasture ecology.

## Temperate pasture

Temperate pastures are typically very productive. They are characterized by well-developed soils, medium to high precipitation and moderate to rapid nutrient cycling. They can be dominated by warm- or cool-season plants and occupy niches from Maine to Florida, from Texas to Minnesota and from Southern California to the Pacific Northwest coastal regions of Washington and Oregon. Many irrigated riverine pastures in the desert and Intermountain West also resemble temperate pastures due to deep soils, adequate moisture from irrigation or high water tables and

*Temperate pasture can be highly productive with proper grazing management.*



*Photo courtesy of USDA NRCS.*

the presence of high-yielding plant species such as brome grass and alfalfa. Temperate pastures will on average yield anywhere from 2,000 pounds of dry matter per acre per year to more than 12,000 pounds per acre depending on the species, soil type, growing season, grazing management and other environmental factors.

## Rangeland

According to the Society for Range Management, rangelands are a type of land on which the natural vegetation is dominated by grasses, forbs and shrubs and the land is managed as a natural ecosystem (SRM). In North America, rangelands include the grasslands of the Great Plains stretching from Texas to Canada, from the prairie states of the Dakotas and Nebraska to the annual grasslands of California and forestlands and wetlands throughout North America. Included in this definition are arid shrublands throughout the western United States, the arctic tundra, and mountain meadows and deserts throughout the Southwest. Rangeland can also encompass pastures of introduced grasses, such as crested wheatgrass, that are managed as rangelands. Arid rangelands, which typify much of Arizona, New Mexico, Colorado, Utah, Nevada, Idaho, Montana, Oregon, California and Washington, can yield anywhere from 200 to 1,500 pounds or more of dry matter per acre per year.

Rangelands are typically characterized by low precipitation, shallow soils and slow nutrient cycling. They are usually dominated by grasses, forbs and shrubs efficient at water and nutrient utilization, so practices that are appropriate to temperate pastures, such as fertilization and plowing, are often inappropriate on rangelands. Regardless, rangelands can be very productive, providing sustainable income for ranch communities while protecting valuable natural resources through appropriate grazing strategies. Specific strategies for sustainable rangeland management are covered below in the sections **Prescribed grazing on rangeland** and **Developing a grazing management plan on rangeland**.



Photo courtesy of USDA NRCS.

*Native rangelands are more fragile than temperate pastures, and often require different approaches to management for sustainable production.*

## Managing soil and forage resources

Fertile soil is the foundation of sustainable production. Soil macro-organisms and microorganisms are the external digestive system that processes organic matter, delivering a smorgasbord of minerals, vitamins and other nutrients to the crop at a metered pace. This contrasts the conventional approach of flooding crops with a limited number of soluble fertilizer nutrients, leading to luxury consumption, imbalanced plant nutrition and a susceptibility to disease and attack by insect pests.

Pasture systems are maintained through grazing and animal impact on the land, which accomplish the following:

- nutrient cycling through feces and urine;
- timely defoliation and removal of plant material that encourages regrowth;
- root death through leaf removal, resulting in underground organic matter accumulation and nutrient cycling;
- increased water-holding capacity through accumulation of soil organic matter; and
- hoof action that breaks soil surface and compacts soil, thereby allowing

greater germination of seeds and encouraging regeneration of pasture swards.

Rotational grazing is a proven method of increasing the efficiency of pasture systems. Intensively managed rotational grazing systems have the potential of maintaining pastures in a vegetative state for most of the growing season in many regions of the country. Coupled with the use of stockpiled pasture and stored forage, the possibility of year-round forage finishing of livestock becomes more feasible in more parts of the country.

In addition, intensively managed grazing systems make it possible to feed livestock without concentrating wastes in manure pits and lagoons, thereby maintaining nutrients within the pasture ecosystem and preventing them from becoming pollutants.

An intensively managed pasture system is appropriate for maximizing gain per acre and maintaining soil and pasture stand health. But to take advantage of the beneficial qualities of an intensively managed pasture system, a grazer should pay careful attention to grass stubble height after grazing. A grazer should be aware of the direct correlation between after-grazing stubble heights and pasture health.

Livestock should be turned onto cool-season grass pastures such as orchardgrass, wheatgrasses, timothy, fescues and more when the grass is from 8 to 12 inches tall, and removed when the stubble height is from 3 to 4 inches tall. Cool-season grasses have the ability to regrow relatively quickly after grazing, given enough time and soil moisture. Cool-season grasses can regrow through tillering (new shoot growth from the crown) or through sprouting new plants by way of underground rhizomes, depending on the species.

Native warm-season grasses such as big bluestem, switchgrass and Indiangrass should not be grazed too short, as heavy

### Related ATTRA Publications

Assessing the Pasture Soil Resource

Dairy Resource List: Organic and Pasture-Based

Managed Grazing in Riparian Areas

Multispecies Grazing

Nutrient Cycling in Pastures

Pastures: Sustainable Management

Pastures: Going Organic

Paddock Design, Fencing, and Water Systems for Controlled Grazing

Rotational Grazing

defoliation can seriously reduce the grass's ability to persist over time. Warm-season grasses will not take the kind of defoliation that cool-season grasses can without causing harm to the pasture. It is also advisable to leave from 6 to 8 inches of stubble after grazing during the growing season for native warm-season grasses. The extra leaf area is needed for the plant to photosynthesize plant sugars and prepare for later winter dormancy. A grazing system that leaves a 12-inch stubble at frost is appropriate for these grasses (Conservation Commission of the State of Missouri, 1984).

Graze warm-season annual grasses such as sorghum-sudan just before heading when the plants are 2 feet tall. Livestock should be removed when these grasses have from 4 to 6 inches of stubble. Take care when grazing sorghum-sudan and related grasses, as prussic acid poisoning can be a problem if grazed too early. See **Plant toxicity** below for more detailed information.

Grazing can begin when grass is shorter on warm-season bermudagrass, bahaigrass and buffalograss pastures because these grasses have a more prostrate growth pattern and can generally handle heavier defoliation. From 2 to 3 inches of stubble on these grasses is not too short.

Cool-season grass yields range from 4 to 6.5 tons per acre, and warm-season pastures can typically yield from 2.5 to 4 tons per acre. In addition, pastures with grasses and legumes grown together typically yield from 10 to 15 percent more forage than monoculture pastures. Producers should determine the annual pasture productivity, as this will provide a baseline of information to make management decisions.

### ***Determining forage yield***

Forage yield can be determined with a pasture ruler or a rising plate meter. A pasture ruler is just that: a ruler calibrated in inches placed on end at ground level, with forage height measured in inches. A rising plate meter measures density as well as height. A 20-inch by 20-inch plate weighing 2.6 pounds is dropped on a rule at waist height.

### **Clip and weigh method**

Construct a 2-square-foot quadrant frame from PVC or copper pipe. Each straight edge should measure 17 inches. Randomly throw the frame on the ground and clip all the plants inside the hoop at ground level. Place the clipped forage into a paper sack and repeat the procedure at least nine more times, placing samples in separate paper bags.

1. To determine percent dry matter, weigh one sample in grams (453.6 grams per pound, 28.47 grams per ounce), and place in a microwave for two minutes on a high setting. Weigh the sample in grams and repeat until no change in weight occurs. Place a small dish of water in the microwave to prevent damage.
2. Calculate the dry matter percentage of the sample by dividing the dry weight by the fresh weight and multiplying by 100.
3. Multiply the percent dry matter by the fresh weights of the remaining samples.
4. Average the weights of all samples and multiply the dry matter weight in grams by 50 to get pounds per acre.
5. Remember to adjust this figure for allowable use. If you wish to use only half the forage in the pasture, multiply the result by 0.50 to get pounds per acre for grazing.

For this measure in Iowa and Missouri, each inch of forage height equals 263 pounds per acre of dry matter and has been verified by numerous clip and weigh field studies. This measure should be calibrated for local conditions by clip and weigh method to obtain accuracy.

A good rough estimate is 300 pounds of dry matter per acre per inch on a ruler. This measure is likely to have from 50 to 80 percent accuracy depending on if you have calibrated your measurement procedure. Jim Gerrish's values range from 150 pounds per acre per inch in a fair stand to 600 pounds per acre per inch in an excellent stand as determined by clipping and weighing numerous quadrants and comparing them to sward heights (Gerrish, 2004). The vast differences in the above estimates reflect differences in pasture types. For example, bermudagrass will most likely be different from

bromegrass when measuring stand density with a ruler or rising plate meter.

Consideration must be given to forage quality and the species of livestock grazing the pasture. The higher the forage quality (vegetative, growing grass and clover), the greater the intake. Please refer to the accompanying box for information on animal intake by species. Understanding how much an animal will eat each day can assist producers in estimating forage demand.

## Intake, sward density and grazing period

Forage intake is directly related to the density of the pasture sward. Ruminants can take only a limited number of bites per minute while grazing, and cattle in particular will only graze for about eight hours per day. It is important to ensure that each bite taken by the grazing animal is the largest bite possible. Cattle graze by wrapping their tongue around and ripping up forage. Large bites of forage are therefore ensured by maintaining dense pastures.

Dense pastures are pastures with actively growing and tillering forage plants. Tillering occurs in grasses that are grazed or mowed while vegetative, resulting in the activation of basal growing points and the initiation and growth of new stems and leaves. Tillering results in a plant covering more basal area, therefore helping make a pasture denser.

The length of the grazing period, or time in a paddock, also has a direct effect on pasture intake. An animal's intake decreases the longer it remains in a given paddock. This happens due to plant disappearance as plants are grazed and cattle search for their next bite. The decrease in crude protein content begins roughly two days after the animals have been turned into the paddock. Jim Gerrish has shown that as an animal remains in a paddock, intake and liveweight gains decrease (2004). It is for this reason that most dairy graziers move high-producing cattle to new paddocks after each milking.

**Table 1. Animal intake by species**

Species	Intake (% of body weight) per day	Intake in pounds per day
Mature cattle	2 to 3	20 to 30
Sheep	2.5 to 3.5	5 to 10
Goats	4 to 5	3 to 5

## Legumes and soil fertility

Legumes like clover, alfalfa, birdsfoot trefoil, sainfoin and vetch have the ability to convert atmospheric nitrogen to the plant-available form of nitrogen through the symbiotic work of rhizobium bacteria, which occur naturally in a healthy soil. In a natural ecosystem, legumes can fix nitrogen at rates ranging from 25 to 75 pounds of nitrogen per acre per year. In cropping systems, the amount is several hundred pounds (Lindemann and Glover, 2003). For well-managed diverse pastures, supplemental nitrogen fertilization can be eliminated altogether. For pastures under high-density grazing systems, from 70 to 85 percent of the nitrogen taken in by the animals is returned and cycled back to the soil in the form of feces and urine. A diverse pasture with a significant legume component that is managed intensively with heavy stocking and frequent moves has the potential to become a stable, closed system.

## Stocking rate

Determining the initial stocking rate for a given pasture is relatively simple, but not necessarily easy. It is simple because the calculations are relatively straightforward. It is not easy because you must familiarize yourself with basic forage growth principles and apply those principles to what you observe on your own pasture.

There are several key issues to consider when thinking about how many animals a pasture will support. Consideration must be given to forage production potential; utilization patterns by livestock; the nutrient content of the forage and forage growth patterns; the plant species that comprise the pasture; species diversity of the pasture

**A**n animal's intake decreases the longer it remains in a given paddock.



plant community; and seasonal variations in temperature and moisture.

Stocking rate can be determined using the following formula:

$$\text{Number of animals} = \frac{\text{pasture size} \times \text{pasture yield per acre}}{\text{daily intake} \times \text{average animal weight} \times \text{days of grazing}}$$

The formula is completed with the following:

1. pasture size in acres
2. pasture yield in pounds per acres of dry matter
3. daily intake as a percent of body weight (2 to 3 percent for cattle, see *Table 1* for other species)
4. average animal weight in pounds for the grazing herd
5. length of the grazing season in days

*Example: Determine the number of 1,000-pound cows a 50-acre pasture will support for 100 days, given a pasture yield of 3,000 pounds of dry matter per acre.*

$$\text{Number of animals} = \frac{50 \text{ acres} \times 3,000 \text{ pounds per acre}}{0.02 \times 1,000 \text{ pounds} \times 100 \text{ days}}$$

*Number of animals = 75*

For very high-quality pasture, the intake rate used in the calculation could be increased to 3 percent for cows. The intake rate may also be increased to account for forage that is trampled or otherwise wasted. If the calculations are for sheep or goats, the daily intake and the average animal weight would be different. See *Table 1* for values.

More information on stocking rate is covered below in the section entitled **Rotational grazing and paddock size**.

## Ecological weed management in pastures

Agricultural systems are very complex biological systems that operate in a particular ecological balance. Each region of the country, indeed each watershed and field, might

behave in very different ways because of differences in soil type and depth; indigenous or local plant cover; cropping systems; and temperature and water availability, not to mention field cropping history. By developing a cropping system or perennial pasture that utilizes nature's own defenses and achieves ecological balance, a sustainable, pest-limited crop can be grown.

### ***Do you really have a weed problem?***

Many plants that are considered pasture weeds are highly palatable and nutritious during the vegetative stage. Take, for instance, dandelion and plantain. Both are plentiful in many pastures, and producers can spend thousands of dollars spraying them with herbicides. They are, however, valuable plants that occupy different root zones and deliver nutrients from different soil depths. They are also very nutritious and palatable when young. These and many other so-called weeds can be a valuable contribution to sustainable pastures. Even our so-called noxious weeds like knapweed and kochia can be grazed by sheep, goats and cattle with skilled management.

Weeds are often a result of soil disturbance and human interference in nature. Weeds are plants that occupy space that humans do not want them to occupy, and farmers have many very good reasons for not wanting weeds to occupy certain spaces. Some are non-native, invasive plants that have the capacity to crowd out or compromise the health of other plants and animals. Those types of weeds may need concerted control strategies. In agriculture we have become very accustomed to taking reactive measures such as pesticide application or mechanical approaches such as cultivation in order to eliminate unwanted plants and establish a favorable environment for the kinds of plants we choose to be there. But if we can look at crop production and pasture as systems and begin to understand how plants, animals and humans interact on a given landscape, weeds will become much less of a problem. By managing croplands and pastures according to natural principles,

we can significantly reduce weed problems. For more information see ATTRA's *Principles of Sustainable Weed Management for Croplands*.

## **Techniques for dealing with problem weeds in pastures**

Keeping weeds out of a pasture is much easier than trying to get rid of a bad infestation. Some management practices for keeping pastures weed-free include:

- terminate low-producing, weedy fields;
- rotate perennial pastures with annuals;
- integrate a high-density rotational grazing system;
- know your pastures; and
- consider multispecies grazing.

The aforementioned methods, used singly or in combination, can easily be incorporated into a pasture management system, setting up a situation in which weeds find it hard to get ground. When pasture stands such as alfalfa get too old, they often begin to decline and allow other plants to take over. Many times the grass component of the field will increase as alfalfa decreases, but in instances of low fertility or drought, weeds can take advantage of the open niche and become established. In these cases, terminating and reseeding the fields is sometimes recommended. Some producers refer to this as farming the pasture. For some pastures that are terminated, you might consider planting to winter wheat or oats and winter peas for a season. These are valuable forage crops and they help to break pest cycles while building soil.

High-density grazing systems also diminish weed invasion by reducing grazing selectivity. As an animal is forced to consume all the plants in a given area, no one plant is favored. This gives grass an advantage. Grass, because of the lowered position of its growing point when vegetative, tolerates leaf removal better than broadleaf plants, which often elevate their growing points much earlier in the season. Very intensive systems

can even favor grass over legume growth, so pay careful attention to the legume component of intensively grazed paddocks. Reseed annual legumes by frost-seeding, feeding seed to cattle, broadcasting in the fall or allowing legumes to go to seed to maintain legumes in these systems. See the section **Pasture renovation and establishment** for more information.

Most of all, know your pastures. Make it a point to understand soil types and how they change with the aspect and slope of the land. Obtain some reference guides that will assist you in identifying the plants on your farm or ranch. Your Cooperative Extension Service is a great place to find these. The more you know about what your pastures will produce, the better position you will be in to make appropriate management decisions.

Remember the principal concerns in managing unwanted pasture plants are:

- encouraging forage growth over weed growth through selection of appropriate livestock species and proper timing of grazing;
- ensuring adequate soil fertility through nutrient cycling, species diversity and inclusion of legumes; and
- rotating non-erodible fields, especially monoculture perennial fields, to break weed cycles.

Perennial pastures on non-erodible land can be rotated with cereals, summer annuals or even vegetables to interrupt weeds, diseases and problem insects.

## **Multispecies grazing**

Multispecies grazing refers to the practice of utilizing different livestock species to:

- diversify farm income;
- utilize pastures of different ecological types on the farm;
- manipulate the plant community to meet the production goals of the farm; and
- interrupt parasite life cycles.

**M**any plants considered pasture weeds are highly palatable and nutritious during the vegetative stage.

**Figure 1. Plant preferences for grazing livestock**

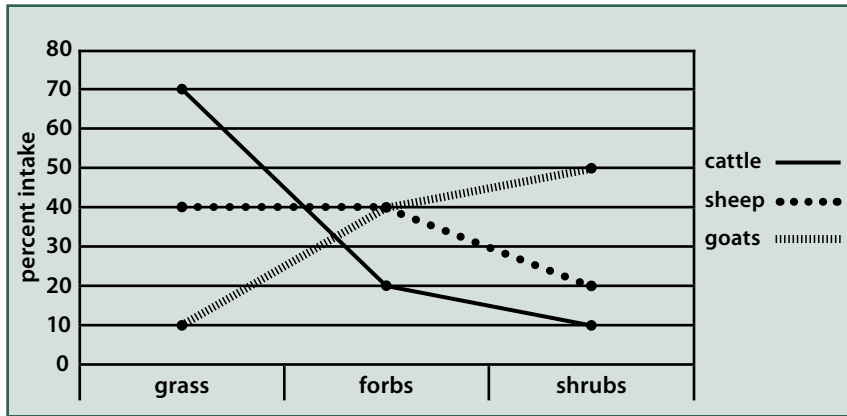

Cattle, sheep and goats evolved eating different plant types. Cattle typically consume, in order of preference, grasses, forbs and shrubs. Sheep will consume, also in order of preference, forbs, grasses and shrubs and goats will seek shrubs, forbs and grasses.

Sheep have been effectively utilized on Western native ranges to control invasive species such as spotted knapweed, leafy spurge and yellow starthistle. Cattle that are grazing in conventional rotations often remain on Western ranges for weeks at a time during the summer and are moved when a set stubble height of key grass species like bluebunch wheatgrass or rough fescue is attained.

When cattle, being primarily grass eaters, remain in a pasture for long periods of time, they tend to exhibit grazing selectivity and choose vegetative grasses and young forbs over knapweed and other noxious weeds. Ranchers who have allowed a band of 800 or more sheep to graze for several days before or immediately after the cattle have seen significant knapweed usage by the sheep, with moderate grass utilization. See *Figure 1* for a comparison of plant preferences for grazing livestock.

Applying pressure with diversified livestock to knapweed, other forbs and grasses in equal amounts will increase range biodiversity significantly over time. Sheep can be used as an alternative enterprise by taking value from wool, lambs or by contract grazing on other parcels to control noxious weeds. Goats have a similar utility in areas with shrub infestation and have been

successfully used to control kudzu, English ivy, scotchbroom, Chinese tallowtree, juniper and mesquite in many parts of the country. Small ruminants can also add value to a farm by providing meat and milk products to growing ethnic groups that seek these traditional foods. Refer to the ATTRA publication *Multispecies Grazing* for more information.

Using small ruminants on cattle operations will necessitate a change in farm and ranch infrastructure. Fencing, lambing sheds and secure paddocks in areas with predators such as wolves, coyotes or bears are often necessary, but costs can add up and drain profitability.

Other methods of maintaining small ruminants on ranches include employing a competent herder who will ensure the sheep or goats graze the necessary places and placing guardian animals such as guard dogs, donkeys or llamas with the livestock for predator control.

For more information see ATTRA's *Predator Control for Sustainable and Organic Livestock Production*. Small ruminants are excellent additions to diversified farms and ranches because they have the ability to remove weed problems by shifting plant succession towards a more complex, balanced stage.

## Pasture renovation and establishment

When is it appropriate to renovate pastures? Renovation often isn't necessary. Many farmers and ranchers have noticed increased productivity and decreased weed problems merely by working out a high-density rotational grazing system. Pastures are very resilient and, when maintained in the vegetative stage for most of the grazing season, ecologically appropriate grasses and forbs often begin to dominate where weeds and other unpalatable plants once proliferated. This happens due to the ecological principle called succession.

Nature tends toward the stability that comes with species complexity. Complex systems

occupy all available space both above and below ground, and therefore utilize nutrients and water more efficiently. Complex systems are more resilient from year to year, as some species will thrive during wet times and others will proliferate during dryer times. Simple systems, on the other hand, are less resilient and are prone to disease and insect attack due to the absence of diversity. In simple systems, one or two species prevail and there are fewer niches for beneficial organisms to occupy. Simple systems also exploit only a single soil layer, and therefore many soil nutrients will remain isolated from the system.

### Ecological succession and grazing management

In nature, ecosystems evolve from simplicity to complexity. Consider a field that is plowed and abandoned. Usually the first plants to show up are annual grasses and forbs, followed by perennial forbs and grasses. As the years progress, the grasses begin to occupy more of the space and some shrubs will establish. If left alone and provided adequate precipitation, the shrubs will dominate. Trees will show up next, and woodland will appear at the height of succession. Managed grazing can hold succession to perennial forbs and grasses by maintaining the pasture in the vegetative, or growing, stage.

For those fields that have been cropped with annuals for the past several decades, renovation and reseeding might be appropriate, especially if high-yielding dairy cattle or growing lambs graze them. What follows is a short discussion on pasture renovation. For more information on field renovation and reseeding, including budgets for pasture establishment on a per-acre basis, see ATTRA's *Converting Cropland to Perennial Grassland*.

### Pasture establishment

Establishing a new pasture is a time-consuming and expensive process. Careful attention should be paid to proper plant material selection; soil tilth and seedbed preparation; soil fertility and the addition of compost or manures; green manure plow-down;

and amendments with rock powders. Plant materials should be adapted to the native soil pH and water-holding characteristics; annual precipitation; temperature; seasonality; and grazing system. This is a good time to incorporate rock phosphate and adjust the soil pH by adding lime according to soil test recommendations.



Photo courtesy of USDA NRCS.

*No-till grass seeders ensure proper seed placement and result in better germination.*

Proper seedbed preparation is very important for establishing a productive pasture. There are essentially three ways to plant pasture grasses and legumes: planting into a prepared seedbed, no-till planting into the stubble of a prior crop or interseeding into an existing stand.

Seed-to-soil contact is of extreme importance when planting by any method. The seed must remain in contact with moist soil for the first month after germination or the seedling will wither. There are various methods for achieving seed-to-soil contact while planting. Drilling with a grass drill is the most effective, as it allows for better control of seed placement. Many times packer wheels follow the drill to firm the seedbed and ensure seed-to-soil contact. Broadcasting seed can be effective for some species, especially if the soil is packed after planting. Pulling a roller or dragging a harrow behind a tractor or four-wheeler is an effective tool to increase the germination of broadcast plantings, especially for ryegrass and clover seeds. Other grass seeds such

**S**eed-to-soil contact is of extreme importance when planting by any method.

as timothy, orchardgrass and most warm-season native grasses do not establish well by broadcasting and should be drilled. Be careful not to plant too deep or the seeds might not germinate. Follow local Cooperative Extension Service recommendations for seeding rate and depth.

Another method of planting new pastures is frost seeding. Frost seeding works well in areas that experience a freeze-thaw pattern in the spring before green-up. Broadcast seeds after snowmelt and allow the natural freeze-thaw action that occurs each day to work the seed into the ground. If the timing is right, this can be an effective way to achieve seed-to-soil contact and incorporate legumes into a grass pasture. For the humid areas of the South or drier areas of the West, fall-seeding of legumes is more appropriate so that seeds can establish during the winter rainy season.

## Rotational grazing and paddock size

If given a choice, livestock will only eat the highest-quality, most palatable plants in a pasture. In order to ensure that plant biodiversity is maintained in the pasture, it is necessary to set up a grazing management system to better control livestock grazing. The elements of grazing to control are the

timing and the intensity. This means controlling the number of animals and how long they are in a pasture.

Rotational grazing systems take full advantage of the benefits of nutrient cycling as well as the ecological balance that comes from the relationships between pastures and grazing animals. High-density stocking for short periods helps build soil organic matter and develops highly productive, dense, resilient pastures. For more information see ATTRA's *Rotational Grazing and Paddock Design, Fencing and Water Systems for Controlled Grazing*.

A rotational grazing management plan need not be complex. It merely has to direct the grazing animal to eat when and where you want them to in order to keep the plants in their growing, or vegetative, stage. Rotational grazing allows for more effective forage utilization by increasing herd size on smaller paddocks for a shorter time, thereby decreasing grazing selectivity and giving the farmer more control of what and when the livestock eat. The basic principles of rotational grazing management include:

- proper timing of grazing corresponding to plant physiological stage;
- proper intensity of grazing, or duration on the pasture;
- residue or plant height after grazing; and
- duration of rest.

Allow the pasture plants to get to sufficient height prior to turning the cattle onto the pasture. By waiting until the grass is from 8 to 12 inches high, depending on species, the roots have become well developed and the plants can handle defoliation. Grazing intensity, or duration, can be taken care of by designing a suitable rotational grazing system. Rotational grazing, as the name implies, involves moving the cattle periodically from pasture to pasture or paddock to paddock. For instance, a good rule of thumb is to split a pasture into 10 or more paddocks with electric wire or electric tape and stock each paddock heavily for a short amount of time. See *Table 2* for

*Paddocks divided by a single electric wire increase options for managing pasture throughout the grazing season.*



*Photo by Linda Coffey, NCAT, taken at Nichols Dairy, Westphalia, KS.*

determining the number of paddocks and paddock size. By doing this you are forcing the animals to eat all that's there, including weedy plants they might otherwise not eat. However, before the animals eat the plants to the ground, move them to the next pasture. This takes into account the third principle. It's important to leave several inches of grass to allow adequate leaf area for subsequent regrowth.

Depending on the species, you will need to leave from 2 to 6 inches of plant stubble at moving time. An 11-paddock rotational grazing system that allows animals to graze each pasture for three days will give each paddock 30 days of rest. These figures are for planning purposes, and it is recommended

**Table 2. Rest periods for selected plants**

	Cool weather	Hot weather
<b>Species</b>	<b>(Days)</b>	
Cool-season grasses	14	35-50
Warm-season grasses	35-40	21
Legumes	21-28	21-28
<i>Blanchet et al., 2003</i>		

to move according to forage height rather than by the number of days on pasture.

Grasses need from 15 to 50 days of rest between grazing events to allow adequate regrowth, depending on season, moisture and plant type. The accompanying chart shows typical rest times for various pasture plants, realizing that water and moisture will have a large effect on plant regrowth.

### Calculating paddock size and number

Two questions that will immediately come up for someone contemplating a rotational grazing system are:

- How many paddocks should I have?
- How big should the paddocks be?

The University of Minnesota Extension gives details for calculating paddock numbers in their *Grazing Systems Planning Guide* (Blanchet et al., 2003). See the **Further resources** section for more information. Essentially, answers to these two questions can be easily acquired by utilizing the following formulas:

To calculate the number of paddocks needed, use the following formula:

$$\text{Paddock number} = \frac{\text{Rest period (days)}}{\text{Grazing period (days)}} + \text{number of animal groups}$$

Example:

$$\text{Paddock number} = \frac{30 \text{ days}}{2 \text{ days}} + 1 \text{ animal group} = 16 \text{ paddocks}$$

Then, to calculate the size of each paddock in acres, use this formula:

$$\text{Paddock size} = \frac{\text{Daily herd forage requirement (pounds)} \times \text{grazing period (days)}}{\text{available forage per acre (pounds)}}$$

Example:

Considering that growing steers will generally consume around 2.5 percent of their body weight, we will estimate the intake of 100 700-pound steers to be 17.5 pounds per animal per day, times 100 animals equals 1,750 pounds daily herd forage requirement. If the animals will be in each paddock for two days, and the available forage in the paddock is 2,000 pounds per acre, then,

$$\text{Paddock size} = 1,750 \text{ pounds} \times 2 \text{ days} / 2,000 \text{ pounds per acre} = \mathbf{1.75 \text{ acres}}$$

Therefore, for a herd of 100 700-pound steers and grass availability of 2,000 pounds per acre, you would need 16 paddocks of 1.75 acres each, allowing for two days of grazing in each paddock before moving the herd to the next paddock. It is very important to realize, however, that 2,000 pounds per acre is not the total productivity of the paddock, but reflects only the amount of forage the animals will be allowed to consume. A dense orchardgrass-timothy pasture in good condition can produce approximately 400 pounds of forage for each inch of plant height. So if you plan to begin grazing when the grass is 10 inches tall, and move the cattle when the grass is 5 inches tall, you should only calculate the 5-inch difference in height in your paddock size calculations. In our example, 400 pounds per inch times 5 inches equals 2,000 pounds per acre of available forage.

*The figures and interpretations in this example are highly variable, and your situation will likely be different from this or any other grazing plan. This example is intended to familiarize producers with the basics of developing a rotational grazing system.*

## Overgrazing

Overgrazing occurs when the grazing pressure exceeds the carrying capacity of the pasture. This condition is not really a function of how many animals are on a pasture, but how long they remain there. In grazing management, time is the most important factor to consider in establishing a grazing system for sustained forage production. Continuous grazing allows livestock to selectively graze the most palatable plants over and over. The problem with this isn't necessarily in the selective grazing activity, but in the fact that the grazed plant does not get the time to regrow before it is grazed again. New growth is more palatable and contains more nutrients than older growth, so animals will come back for a second and third bite as long as they are in the pasture, resulting in the most palatable forages being killed out.

Divide pastures into enough paddocks to ensure that all plants have ample time to regrow after grazing. In addition, for pastures with adequate water during the growing season, a very high stock density encourages animals to graze the pasture more uniformly than if the pasture was lightly stocked. In this situation the so-called weedy species are being grazed at the same intensity as the so-called good species.

## Plant species and systems for extending the grazing season

Species used to extend the grazing season include cool-season annual grasses such as ryegrass and cereal grains; forage brassicas such as kale, rape and turnips; warm-season annual grasses such as sorghum-sudan hybrids, pearl millet and corn; and legumes such as Austrian winter pea (cool-season) and forage soybeans (warm-season). These annual crops can be incorporated in a perennial pasture by several methods.

Annual ryegrass and cereal grains such as oats, wheat and rye can be overseeded into warm-season pastures in the fall. These pastures will be ready to graze in December to

January in the Deep South, and early spring for parts farther north. Ryegrass establishes well when broadcasted into perennial sod, but small grains typically establish better when drilled into sod.

Brassicas can be spring or summer planted into corn or other annual crops to provide late summer or fall forage for livestock. These crops produce as much as 12,000 pounds per acre and are well suited to strip-grazing.

Warm-season annuals like pearl millet, corn and sorghum-sudan are highly nutritious and provide quality forage during the summer when cool-season pastures such as orchardgrass, fescue and brome grass slow down. Summer annuals fit nicely in rotational grazing systems. Careful attention to drought-stressed plants is warranted as these are susceptible to excessive nitrate accumulation, prussic acid accumulation or a combination of the two and subsequent livestock poisoning. Contact your local Cooperative Extension Service office for information on testing for these compounds.

Other species that can be used successfully to extend the grazing season are Austrian winter pea and forage soybeans. Winter pea, a cool-season legume, is often used as a cover crop in cereal rotations. Spring grazing of winter pea allows ranchers to rest more sensitive pastures and graze them when the soil is drier and the vegetation better established. Forage soybeans likewise have a place in summer cropping systems where farmers are rotating crops such as corn or grain sorghum with legumes to build soil organic matter. Grazing these crops for several months before plowing down the green plants is an added bonus to building soil organic matter and tilth.

Annual forage crops can be an excellent addition to a farm since they extend the grazing season several weeks or even months. However, annual cropping systems often come with environmental costs such as erosion, loss of organic matter and destruction of soil structure, most notably when soils are heavily tilled. Consider rotating annual crops to different fields each year

**D**ivide pastures into enough paddocks to ensure that all plants have ample time to regrow after grazing.

to minimize environmental impacts such as water or wind erosion.

## Stockpiling forages

Stockpiling is defined as letting forage grow during summer and deferring grazing to the fall or winter. This is an effective way of providing winter forage in some areas and can reduce the need for harvested forage. If it reduces hay use at all, significant savings can be realized. This system works well for early winter when spring-calving cows are in mid pregnancy. Stockpiled grazing can be followed with meadow feeding of high-quality alfalfa hay prior to calving.

Stockpiling has been shown to work well given appropriate pasture management and efficient allocation of dormant pasture during the winter. Many grass species will maintain a relatively high nutrient content and palatability for several months after dormancy begins. Two extra months of grazing can significantly reduce the costs associated with producing and feeding hay. In some cases, producers have been able to utilize stockpiled forage and eliminate the need for hay feeding completely. This usually works better in climates where the dormant grass can be preserved longer under adequate snow cover or because of reduced microbial decomposition caused by low temperatures and limited moisture.

Stockpiled forages can be fed by either limit-feeding (allowing only so many hours of grazing per day) or by strip-grazing with a movable electric wire or tape. Another option for feeding stockpiled forages is to swath them with a hay mower and then rake them into windrows. Cattle can graze directly off the windrow during the winter by using an electric wire or electric tape to ration hay on a daily basis. This is similar to strip-grazing in that the wire is moved each day to expose a predetermined amount of forage for grazing. This method, while still relying on a tractor to cut and windrow the hay, reduces the amount of fuel, materials and hay equipment needed for bale-and-feed-hay by eliminating the baling process altogether. This method works best in dryer

**Table 3. Forage species for stockpiling**

In the North and West	In the South and East
Altai Wildrye	Bermudagrass
Orchardgrass	Tall Fescue
Reed Canarygrass	Reed Canarygrass
Timothy	
Alfalfa	

regions where weathering is less likely to reduce the nutritional quality and palatability of the hay.

For more information on grazing season extension call ATTRA at 1-800-346-9140.

## Prescribed grazing on rangeland

Prescribed grazing can be thought of as a process of developing a grazing system that seeks to integrate the economic and ecological realities that ranchers are faced with on the Western range. The USDA defines prescribed grazing as “the controlled harvest of vegetation with grazing or browsing animals, managed with the intent to achieve a specified objective” (USDA, 1997).

Management objectives addressed by prescribed grazing include:

- Improve or maintain the health and vigor of selected plants and maintain a stable and desired plant community;
- Provide or maintain food, cover and shelter for animals of concern;
- Improve or maintain animal health and productivity;
- Maintain or improve water quality and quantity; and
- Reduce accelerated soil erosion and maintain or improve soil condition for susceptibility of the resource (USDA, 1997).

A very crucial aspect of a prescribed grazing regime is the development of a workable and ecologically appropriate grazing management plan.



## Developing a grazing management plan on rangeland

Designing an effective grazing plan isn't as daunting as it seems. Mostly it is applying observation to management, observing some more and then adjusting as needed. There are five steps in developing a grazing plan. They are:

- 1) Create an inventory
- 2) Define goals
- 3) Determine grazing units
- 4) Develop a grazing schedule
- 5) Develop a monitoring and evaluation plan (Montana DNRC, 1999)

### Create an inventory

This is for gathering baseline information to allow you to make appropriate decisions about land and pasture use. Obtain soil maps from your Natural Resources Conservation Service office and mark appropriate land forms, soil types and fences and paddocks. Find out what plants are in each pasture and evaluate the pastures based on a condition score. Utilize features such as key species, percent canopy cover, amount of bare ground, presence of noxious weeds, annual forage production in pounds per acre and amount of residue to determine pasture condition and productivity.

### Define goals

Make a list of what you want to accomplish. This will be a list of your expectations and will guide you in making plans and decisions. Do you want to improve the economic value of the ranch? Maintain wildlife habitat? Improve water quality and quantity? Reduce noxious weeds? Also consider available acreage and the amount of time you have to put into this project.

### Determine grazing units

Divide the pastures into units that you can rotate animals through. This will allow you to rest pastures and allow for regrowth

following grazing. It will also allow you to rotate grazing on a seasonal basis. Determine how much forage is available in each grazing unit and map it out. Note key species, percent cover, water availability, facilities and other aspects important to you. Remember that livestock should always be within a two-hour walk from water. This will help you to determine grazing unit size for large parcels.

### Develop a grazing schedule

This will be a graphic illustration of your plans for grazing each unit during the grazing season. Develop the schedule based on your total animal units and available animal unit months in each unit. If you have a 100-acre pasture with two animal unit months per acre, you have 200 animal unit months of forage available. At 50-percent allowable use, cut it in half to 100 animal unit months. This means you have enough forage available to feed 100 animals for one month. Or, said another way, 50 animal units for two months, 33 for three months and so on. For more detailed information on calculating animal unit months, see the Montana Grazingland Animal Unit Month Estimator located at [www.mt.nrcs.usda.gov/technical/ecs/range/technotes/rangetechnoteMT32.html](http://www.mt.nrcs.usda.gov/technical/ecs/range/technotes/rangetechnoteMT32.html)

Important concepts here are duration of grazing and time for regrowth. Some range ecologists and managers believe that grazing intensity is also important, and it is. A plant needs to have green leaves left after grazing for photosynthesis and subsequent regrowth. However, others feel that grazing severity isn't as important as regrowth time. Whichever you choose, it is important to remember to allow plenty of time for adequate regrowth before the animal gets to bite a plant a second time. Take a look at the native plants on an upland range site if you have the opportunity. Some, like bluebunch wheatgrass and little bluestem, are large-statured and can handle several bites from an animal in one grazing event. Some, like Sandburg bluegrass, Idaho fescue and black grama, are smaller and one bite is all it takes to reduce the plant to stubble.

**R**emember that livestock should always be within a two-hour walk from water.

Cattle especially tend to graze severely, so don't get too caught up in how much they take off. Strive for 50-percent use and allow for regrowth. For some sites on dry ranges, this will mean one grazing event per year. For areas with more moisture, you might be able to return every 15 to 30 days for another grazing event.

## ***Develop a monitoring and evaluation plan***

This is the most neglected part of range management, and the most important. A good monitoring system will allow you to check how your management decisions are working on the ground. It will allow you to determine, for instance, if a particular grazing plan is having the desired effect over time. A monitoring plan will often involve a few important evaluation criteria, such as plant species composition, percent cover and frequency of species. By comparing these measurements over time, you can start to see trends and can alter and adjust your grazing system in order to arrive at your goals.

Recordkeeping is a very important part of pasture monitoring. In addition to recording the aforementioned physical measurements, keep track of when livestock enter and leave a pasture; what materials or chemicals are used; revegetation or weed control treatments; and observations on cattle health while in the pasture. This information will be extremely useful in refining your grazing plans.

To obtain more detailed information on rangeland monitoring contact ATTRA at 1-800-346-9140.

## **Managing for drought**

Drought is a natural ecosystem process. The concept of an average or normal precipitation or temperature is a fabrication that humans use to try to understand complex systems and attempt to predict behaviors and outcomes. Whether in a humid zone or an arid environment, a producer will experience relative wet and dry years.

Dealing with the dry years is a real challenge to livestock operations that rely on water to grow the plants and recharge the aquifers and streams that feed the animals. Having a drought plan is a very important component of a well-thought-out farm or ranch management plan.

A drought-management option that deserves serious consideration is for a producer to maintain livestock numbers at 75 percent of carrying capacity for normal years and utilize the extra forage in wet years for high-value animals such as stockers (Ruechel, 2006). In dry years the pastures will be better able to accommodate current livestock numbers. Another option is to slow down rotations during dry years, thereby allowing more paddock or pasture rest time. This option can be effective especially when the herd is split between different pastures to minimize the impact on drought-stressed plants.

If you must de-stock during drought, consider which animals should be the first to go. Do you have low-producing females? Do you have older calves that can be sold as stockers? Whichever you do, be sure not to de-stock too late. Pasture that is overstocked and drought-stressed is hard to repair, whereas a cow herd can be bought when rains return.

*A rangeland monitoring photo of a transect in southwestern Montana. Photo points such as this help range managers evaluate changes in vegetation due to grazing management.*



*Photo by Lee Rinehart, NCAT*

## Plant toxicity

Graziers must pay careful attention to the negative health effects that certain plants can cause in livestock. Plant toxicosis occurs either through the ingestion of poisonous plants or forage plants that contain toxic substances due to environmental or physiological conditions. Plant poisoning from water hemlock, nightshade or astragalus can be significantly reduced by proper grazing management. These poisonous plants contain resins, alkaloids and organic acids that render them unpalatable. If the pasture contains enough good forage, there is little reason for the animals to select bad-tasting plants. Contact your local Cooperative Extension Service office for information on poisonous plants in your area.

### Your local Cooperative Extension Service office

Contact your local Cooperative Extension Service office for information on poisonous plants, forage nitrate testing and locally adapted forages. The USDA maintains an online database of local Cooperative Extension Service offices on its Web site at [www.csrees.usda.gov/Extension/index.html](http://www.csrees.usda.gov/Extension/index.html). You will also find the phone number for your Cooperative Extension Service office in the county government section of your telephone directory.

The following section illustrates some of the more common and economically important environmentally or physiologically caused disorders.

### ***Bloat***

Livestock can bloat when they consume vegetative legume pastures such as clovers and alfalfa. Bloat is a condition manifested by the distention of the rumen, noticed as a severe protrusion on the animal's left side caused by fermentation gases that are not able to escape. Legumes are high in protein and the more immature the plant, the higher the concentration of proteins it contains. These proteins are very rapidly digestible and produce gas very quickly, faster than the animal can expel. Control is accomplished one of four ways:

- ensuring the legume component is less than 50 percent of the pasture stand composition;

- feeding one-third of the daily dry matter requirement as long-stem grass hay before grazing lush pastures that contain greater than 50 percent alfalfa or clovers;
- planting a non-bloating legume like Cicer milkvetch, sainfoin or birds-foot trefoil; and
- feeding an anti-foaming agent, usually composed of fats, oils or synthetic surfactants.

Organic producers should make sure that they do not feed prohibited materials. Any treatments they use or plan to use must be listed in their organic system plan and approved by the organic certifier before use.

### ***Grass tetany***

Grass tetany is caused by low blood levels of magnesium (Mg). When succulent cool-season grasses are grazed early in the spring, the condition can have a rapid onset. Symptoms include lack of coordination, staggering and eventually death. Grass tetany is prevented by:

- delaying spring grazing;
- feeding a legume hay with spring grass pastures since legumes are higher in magnesium than grasses;
- providing a mineral supplement; and
- grazing early spring pastures with less tetany-prone animal such as steers, heifers and cows with older calves, since pre- and post-partum cows are most susceptible to grass tetany.

### ***Prussic acid***

Prussic acid, or hydrocyanic acid, is a toxin that occurs in annual grasses such as Johnsongrass, sorghum and sorghum-sudan hybrids. When these grasses are stressed due to drought or frost, prussic acid levels accumulate and, if grazed by livestock, will cause salivation, labored breathing and muscle spasms. Death can occur very

quickly after consumption. Prussic acid does not persist like nitrates do. Forage that has been ensiled or harvested as hay and dried to a less than 20-percent moisture content is safe for consumption. Prussic acid poisoning can be prevented by:

- testing for prussic acid if conditions are right;
- avoiding grazing for a week after the end of a drought since young plant tissue after a drought-ending rain will be high in prussic acid;
- avoiding grazing for a week after a killing frost;
- considering pearl millet as a warm-season annual forage since pearl millet does not produce prussic acid; and
- avoiding turning hungry livestock into a suspect pasture.

Testing for prussic acid requires timely delivery to the lab, as cyanide levels decline after the plant is harvested. Refrigerate but do not freeze samples if you cannot get them to the lab right away. If mailing samples to the lab, mail them on a Monday to reduce shipping time.

Contact your local Cooperative Extension Service office for information on forage prussic acid testing.

## **Nitrates**

All plants contain nitrates, which are the precursor to plant proteins. Excess nitrates will accumulate in the lower stems of some plants when plants are stressed. This can occur during a drought, heavy rain or long period of cloudy weather. In effect, nitrate accumulation occurs when photosynthesis slows down. During this time the plant may not be metabolizing nitrates, but it will still be taking nitrates from the soil. The result is a backlog of poisonous nitrates in the plant stems. Concentrations of 1.5 percent or more in plant tissue can be toxic to livestock, and concentrations of less than 0.25 percent are considered safe. Excess nitrates can be deadly to livestock, and the

most commonly affected plants are annual grasses such as the cereal grains including oats, wheat and barley; warm-season annual grasses such as sorghum, pearl millet and corn; and broadleaf plants such as pigweed, thistles, goldenrod and lambsquarters. In contrast to prussic acid, nitrate toxicity in forage does not decrease with time. Nitrate poisoning can be prevented by:

- testing of suspected plant tissue prior to feeding;
- harvesting or grazing suspected forages several days to a week after the end of a drought;
- beginning harvest or grazing of suspected forages in the afternoon after the plants have had several hours of sunlight since this helps the plants metabolize nitrates;
- chopping forage and diluting with clean hay; and
- minimizing nitrogen fertilization.

Contact your local Cooperative Extension Service office for information on forage nitrate testing.

## **Fescue toxicosis**

Another important condition to consider in the South and Midwest is fescue toxicosis, which is caused by fungi growing symbiotically with the plant. Three distinct ailments can occur when livestock consume infected tall fescue. Fescue foot results in fever, loss of weight, rough hair coat and loss of hooves or tail switch. Bovine fat necrosis is a syndrome characterized by hard fat deposits in the abdominal cavity. Summer slump is evidenced by fever, reduced weight gain, intolerance to heat, nervousness and reduced conception. Fescue toxicosis can be reduced by:

- seeding of legumes to dilute fescue intake;
- early close grazing of fescue to reduce seed development;
- restricting nitrogen fertilization to the summer when warm-season grasses are actively growing; and

**E**xcess nitrates can be deadly to livestock and the most commonly affected plants are annual grasses.

- replanting with endophyte-free seed or another grass species such as orchardgrass.

*Southern Forages*, a book listed in the **Further resources** section, has an excellent entry on fescue toxicity in its Common Forage-Livestock Disorders chapter.

## Summary

When a livestock farmer relies on pasture or rangeland to supply the protein and energy requirements of livestock, it benefits the farm, the watershed and the community in significant ways. The management practices that foster a more sustainable agriculture system are founded on a management philosophy that values health in people, animals, plants and soil.

Pasture-based animal agriculture promotes environmental stewardship and community development through certain key management practices, including limiting the use of off-farm inputs such as diesel, fertilizer and purchased feed; and toxic substances such as pesticides. Soil conservation practices, such as limited tillage and use of perennial pastures, store carbon in the soil while building soil organic matter.

The biological diversity of the pasture is enhanced through grazing management, especially through planned grazing systems that provide adequate rest and regrowth. Conserving water and energy resources through irrigation monitoring; solar and wind technologies; and biofuel development can enhance farm sustainability. The selection of adapted plant and animal genetics to local conditions can enhance the health and resilience of the whole farm community.

Marketing food to local communities tends to reduce the distance food travels from farm to plate and provisions the community with better, fresher food. Local processing plants add value to local animal products while providing employment and economic development.

## Acknowledgement

Special thanks to Melvin George, a rangeland management specialist with University of California Cooperative Extension, for providing technical review and input to this publication.

## References

- Blanchet, K., H. Moechnig, and J. DeJong-Hughes. 2003. *Grazing Systems Planning Guide*. St. Paul: University of Minnesota Extension Service.
- Conservation Commission of the State of Missouri. 1984. *Native Warm-Season Grasses for Missouri Stockmen*.
- Gerrish, J. 2004. *Management-intensive Grazing: The Grassroots of Grass Farming*. Ridgeland, MS: Green Park Press.
- Lindemann, W.C. and C.R. Glover. 2003. *Nitrogen Fixation by Legumes, Guide A-129*. Las Cruces, NM: New Mexico State University Extension.
- Montana DNRC. 1999. *Best Management Practices for Grazing in Montana*. Helena, MT: Montana Department of Natural Resources.
- Ruechel, J. 2006. *Grass-Fed Cattle: How to Produce and Market Natural Beef*. North Adams, Mass.: Storey Publishing.
- SRM. No Date. *Rangeland Resources of North America*. Lakewood, CO: Society for Range Management. Article accessed at [www.rangelands.org/publications\\_brochures.shtml](http://www.rangelands.org/publications_brochures.shtml).
- USDA. 1997. *Conservation Practice Standard, Prescribed Grazing, Code 528A*. USDA Natural Resources Conservation Service. [www.aces.edu/department/aawm/al528a.pdf#search='prescribed%20grazing'](http://www.aces.edu/department/aawm/al528a.pdf#search='prescribed%20grazing')

## Further Resources

---

### *ATTRA publications*

Assessing the Pasture Soil Resource  
Dairy Resource List: Organic and Pasture-Based  
Managed Grazing in Riparian Areas  
Multispecies Grazing  
Nutrient Cycling in Pastures  
Pastures: Sustainable Management  
Pastures: Going Organic  
Paddock Design, Fencing, and Water Systems for Controlled Grazing  
Rotational Grazing

### *Grazing behavior and livestock handling*

*Foraging Behavior: Managing to Survive in a World of Change; Behavioral Principles for Human, Animal, Vegetation, and Ecosystem Management*

Fred Provenza, PhD  
Utah State University

[www.behave.net/products/booklet.html](http://www.behave.net/products/booklet.html)

*Stockmanship: Improving rangeland health through appropriate livestock handling*

Steve Cote

Order from the Natural Resources Conservation Service and the Butte Soil and Water Conservation District  
P.O. Box 819

125 S. Water St.  
Arco, ID 83213  
(208) 527-8557

[www.grandin.com/behaviour/principles/Steve-Cote.book.html](http://www.grandin.com/behaviour/principles/Steve-Cote.book.html)

### *Grazing systems: Planning and management*

*A Guide for Planning, Analyzing, and Balancing Forage Supplies with Livestock Demand*

Lacey, J., E. Williams, J. Roller, and C. Marlow.  
1994. Bozeman, MT: Montana State University Extension.

[http://animalrangeextension.montana.edu/Articles/Forage/grazing/guide\\_planning.pdf](http://animalrangeextension.montana.edu/Articles/Forage/grazing/guide_planning.pdf)

### *Grazing management: an ecological perspective*

Rodney K. Heitschmidt and Jerry W. Stuth  
<http://cnrit.tamu.edu/rlem/textbook/textbook-fr.html>

*According to its foreword, this book was written to help resource managers broaden their perspective relative to management of grazing animals and heighten their awareness of the role*

*they play in maintaining the integrity of ecological systems. Published by Timber Press in Portland, Ore.*

### *Grazing Systems Planning Guide*

Kevin Blanchet, University of Minnesota Extension Service

Howard Moechnig, Natural Resources Conservation Service

Minnesota Board of Water and Soil Resources,  
Jodi DeJong-Hughes, University of Minnesota Extension Service

University of Minnesota Extension Service Distribution Center

405 Coffey Hall

1420 Eckles Ave.

St. Paul, MN 55108-6068

[order@extension.umn.edu](mailto:order@extension.umn.edu)

[www.extension.umn.edu/distribution/livestocksystems/DI7606.html](http://www.extension.umn.edu/distribution/livestocksystems/DI7606.html)

*Delineates the components of a grazing system by taking the farmer through the grazing management planning process.*

### *Management-intensive Grazing: The Grassroots of Grassfarming*

Jim Gerrish, Green Park Publishing

This book can be obtained through The Stockman Grassfarmer's Bookshelf at 1-800-748-9808.

*The industry standard for growing and managing pastures for sustained livestock production.*

### *Pastures for profit: A guide to rotational grazing*

Cooperative Extension Publications

45 N. Charter St.

Madison, WI 53715

<http://learningstore.uwex.edu/pdf/A3529.pdf>

*Grazing ecology and setting up a rotational grazing system.*

### *Pasture for Dairy Cattle: Challenges and Opportunities*

Donna M. Amaral-Phillips, Roger W. Hemken, Jimmy C. Henning, and Larry W. Turner. University of Kentucky Cooperative Extension.

[www.ca.uky.edu/agc/pubs/asc/asc151/asc151.pdf](http://www.ca.uky.edu/agc/pubs/asc/asc151/asc151.pdf)

### *Southern Forages*

Donald M Ball; C S Hoveland; Garry Lacefield

Atlanta, Ga.: Potash & Phosphate Institute: Foundation for Agronomic Research, 1991. Fourth Edition 2007.

<http://ppi-store.stores.yahoo.net/soutfor.html>

*The book Southern Forages was first introduced in 1991 and has since gained wide recognition as a practical and reliable source of information on modern forage crop management.*

#### *Selecting forages*

#### *Fertility Pastures*

Newman Turner

Faber and Faber, 24 Russell Square, London

*Classic text on herbal lays, soil health and profitable livestock production on pasture.*

*Out of print. Used bookstores and interlibrary loan might yield good results obtaining this worthwhile book.*

#### *Forage Information System*

<http://forages.oregonstate.edu/index.cfm>

*A comprehensive Web site for forage-related topics, including publications, educational opportunities and professional resources. Maintained by Oregon State University.*

#### *Intermountain Planting Guide*

USDA Agricultural research Service, Utah State University, Logan, Utah

Order from USU Extension Publications

(435) 797-2251

<http://extension.usu.edu/cooperative/publications/>

#### *Organizations*

Holistic Management International

1010 Tijeras Ave. NW

Albuquerque, NM 87102

(505) 842-5252

[hmi@holisticmanagement.org](mailto:hmi@holisticmanagement.org)

[www.holisticmanagement.org/](http://www.holisticmanagement.org/)

*HMI is a goal-oriented, decision-making system for ecological management of resources, people and capital.*

Rangelands West

Western Rangelands Partnership, Agriculture Network Information Center,

University of Arizona

<http://rangelandswest.org/>

*Web-based educational tools and information to assist resource managers improve rangelands and maintain sustainability.*

Quivira Coalition

1413 Second Street, Suite 1

Santa Fe, NM 87505

(505) 820-2544

[www.quiviracoalition.org/index.html](http://www.quiviracoalition.org/index.html)

*Publications on ecological resource management including range management, grazing, road construction, monitoring and managing resources at the urban-rural interface.*

#### **Pasture, Rangeland and Grazing Management**

By Lee Rinehart

NCAT Agriculture Specialist

© 2006 NCAT

Updated Nov. 2008

Holly Michels, Editor

Amy Smith and Robyn Metzger, Production

This publication is available on the Web at:

[www.attra.ncat.org/attra-pub/past\\_range\\_graze.html](http://www.attra.ncat.org/attra-pub/past_range_graze.html)

or

[www.attra.ncat.org/attra-pub/PDF/past\\_range\\_graze.pdf](http://www.attra.ncat.org/attra-pub/PDF/past_range_graze.pdf)

IP306

Slot 301

Version 121108



# Ruminant Nutrition for Graziers

A Publication of ATTRA - National Sustainable Agriculture Information Service • 1-800-346-9140 • [www.attra.ncat.org](http://www.attra.ncat.org)

By Lee Rinehart  
NCAT Agriculture  
Specialist  
©2008 NCAT

## Contents

Introduction.....	1
The Value of Grassland Agriculture.....	2
Ruminant Physiology ....	4
Nutrient Requirements of Grazing Livestock.....	5
Forage Resources and Grazing Nutrition .....	11
Matching Nutritional Requirements of Livestock to the Forage Resource .....	13
Supplementing Protein or Energy: When is it Necessary? .....	14
Forage Sampling and Production (Yield) Estimates.....	15
Plant Toxicity and Grazing-Related Disorders.....	16
Grazing Management .....	16
References.....	17
Resources .....	18

Cattle, sheep and goats have the ability to convert plant carbohydrates and proteins into available nutrients for human use, making otherwise unusable land productive. However, proper care of the land and its grazing animals requires a sound understanding of ruminant nutrition. This publication provides managers with tools and references to consider biological and climatological variables and make decisions that ensure the ecological and economic viability of a grass-based ruminant livestock operation.



Cattle. Photo courtesy of NRCS.



Sheep. Photo by Linda Coffey, NCAT.



Goat. Photo courtesy of USDA.

## Introduction

Grazing animals are very important to agriculture. Of course, they provide meat, milk, and fiber. But grazing animals also can be incorporated into a crop rotation to take advantage of nutrient cycling. They can be utilized to control weeds or to harvest crop residues. Grazing animals can also be an added source of income, diversifying farm enterprises and thereby rendering a farm more sustainable from an economic point of view.

This publication covers the basics of animal nutrition from a grazing perspective. Much of what we understand about livestock nutrition has been developed from studies and experience with confinement feeding operations, where concentrated nutrients in the form of grain, oilseed products, and harvested forages are delivered to animals in a drylot. These types of practices leave out many of the biological and climatological variables that accompany grazing situations: plant species, forage stage of maturity, soil fertility and water holding capacity, annual and





seasonal precipitation and mean temperature, etc. As they plan for the nutritional needs of their grazing animals, graziers need to take each of these variables into consideration. This publication provides livestock managers with the tools and references to consider all the variables and make informed decisions that ensure the ecological and economic viability of a livestock operation.

A ranching operation can appropriately be thought of as a forage production and utilization enterprise. Ranchers are in the business of converting sunlight, water, and carbon dioxide into a high-quality human food source. (Lalman, 2004a) Grasslands and rangelands occupy a large proportion of the U.S. land area. These ecosystems are naturally able to capture sunlight and convert it into food energy for plants. Humans have harvested plant energy for thousands of years—since the beginnings of agriculture. Literally millions of tons of plant-derived food energy is harvested off arable lands each year in the United States. But most of the land in the U.S., and indeed in most countries of the world, is not tillable and is considered rangeland, forest, or desert. These ecosystems can be very productive from a plant biomass perspective, but since they are generally non-farmable, the plants they produce (grasses, forbs,

shrubs, trees) are not readily usable (from a digestive standpoint) by humans.

However, grassland ecosystems (both rangeland and temperate grasslands) produce plant materials that are highly digestible to ruminant animals. *Ruminant* refers to grazing animals that have the ability to digest and metabolize *cellulose*, or plant fiber, and ferment it to form the volatile fatty acids and microbial proteins that the animal can then digest and use. This is of particular importance to the sustainability of agricultural production systems because grasslands and rangelands have the capacity to produce millions of tons of this energy source. Grazing of native and introduced forages on grasslands and rangeland thus is a very efficient way of converting otherwise non-digestible energy into forms available for human use: milk, meat, wool and other fibers, and hide.

## The Value of Grassland Agriculture

Forages are plants, either wild or tame, that are consumed as livestock feed. Grasses, clovers and other forbs (broadleaf vascular plants), shrubs, and even some trees serve as forage for livestock, depending on the ecology of the region. Arable land in the United States, or land that is capable of being cultivated, accounts for only forty-three percent of the country's agricultural area (FAO, 2002). Arable cropland can be rotated into pasture to take advantage of the soil-building characteristics of perennial grass ecosystems. Also, perennial grasses tend to positively affect water quality by serving as buffers in riparian zones and increasing the water-holding capacity of soils. Perennial grasses and forbs as a component of annual cropping systems also help to reduce fuel and chemical use, allowing some fields to be in pasture or hayfield for several years between annual crop rotations.

In North America, more than 50 percent of the land area is rangeland and thus potentially grazable. The topography, soil characteristics, and water availability in these ecosystems usually limit

### Seven Principles of Ruminant Nutrition

1. Ruminants are adapted to use forage because of microbes in their rumen.
2. To maintain ruminant health and productivity, feed the rumen microbes, which in turn will feed the ruminant.
3. Ruminant nutritional needs change depending on age, stage of production, and weather.
4. Adequate quantities of green forage can supply most—if not all—the energy and protein a ruminant needs.
5. Forage nutritional composition changes depending on plant maturity, species, season, moisture, and grazing system.
6. Supplementation may be necessary when grass is short, too mature, dormant, or if animal needs require it (i.e., high-producing dairy animal).
7. Excessive supplementation may reduce the ability of the rumen microbes to use forage.

## Soil Building Characteristics of Grassland Ecosystems

Pastures help to increase organic matter and humus in the soil, which results in:

- Granulation of soil particles into water-stable aggregates
- Decreased crusting
- Improved internal drainage
- Better water infiltration
- Fixation of atmospheric nitrogen
- Release of bound nutrients
- Increased water and nutrient storage capacity

Source: Beetz, 2002

the kind of agriculture that can be developed on them to the grazing of livestock. Livestock management on arid rangelands has been extensively addressed by Allen Savory and Jody Butterfield of Holistic Management International ([www.holisticmanagement.org](http://www.holisticmanagement.org)). Savory coined the term “brittle environment” to denote ecosystems that receive either low annual precipitation or experience unpredictable and sporadic precipitation. (Savory and Butterfield, 1998) These environments are usually characterized by shallow soils, limited moisture, and drought-tolerant perennial grasses, forbs, and shrubs. Brittle environments respond very slowly to ecological disturbance. Savory has suggested that the proper distribution, timing, and intensity of grazing in these regions can have a significant and positive effect on the health of brittle environments. For more information see the above website or contact ATTRA at 800-346-9140.

The principal attribute describing grassland ecosystems and ruminant nutrition is *interconnectivity*. Grasslands and ruminant animals are intrinsically related, and practices that impact one will necessarily impact the other. From the soil the system derives water, nutrients, structural support, and temperature buffering. Soil populations of microorganisms recycle nutrients and make otherwise unavailable nutrients available for plant uptake. Microorganisms also populate the rumens of grazing

ruminant livestock and wildlife, performing symbiotic duties within the animal’s body. Animals occupy a niche and complete the nutrient cycle by returning up to 90 percent of ingested nutrients back to the soil in the form of feces, urine, and their own bodies after death. Humans play an important role in this system as well. We engage in agriculture and derive food and fiber from the system for our consumption.

Cattle, sheep, and goats have the ability to convert plant carbohydrates and proteins into available nutrients for human use, and therefore render productive vast portions of otherwise unusable land. Grasslands offer humans a nutritious supply of meat and milk. Many farmers and ranchers have changed production practices to take advantage of this natural process, bypassing the energy intensive grain-fed operations that have dominated American livestock production for the past several decades. Products from grass-finished livestock are higher in omega-3 fatty acids and conjugated linoleic acid than conventionally raised counterparts. Additionally, these products may reduce cholesterol and reduce the incidence of certain types of cancer. For more information on the nutritional



Photo courtesy of USDA, NRCS.

benefits of grass-based agriculture, visit Jo Robinson's website [www.eatwild.org](http://www.eatwild.org).

## Ruminant Physiology

Proper care of the land and its grazing animals requires a sound understanding of ruminant nutrition. First we must understand how a ruminant animal (cattle, sheep, goats) digests plant matter.

Ruminant comes from the word “rumen,” which is the first major compartment in the four-compartment stomach of the cow, sheep, and goat. This structure is the “furnace” where microbial fermentation takes place. Millions of bacteria, protozoa, and fungi live in the rumen and break down energy-rich plant parts, making them digestible for the host animal. After the forage has been digested in the rumen and is broken down into small pieces, it can pass through the *reticulum* and *omasum*, which function as strainers that keep large pieces of material from passing into the *abomasum*, or “true stomach,” where digestion continues. From the abomasum onward, the ruminant digestive system closely resembles other animal digestive systems with a small and large intestine, colon, and anus.

### Benefits of Ruminant Physiology

As stated earlier, grazing animals have the ability to harvest and convert plant energy, especially cellulose, from grasslands and rangelands not suited to

### The Role of Rumen Microorganisms

- Production of cellulase (to break down fiber-rich plant material)
- Synthesis of volatile fatty acids (used as energy by the animal)
- Synthesis of vitamins
- Synthesis of microbial protein

cultivation. Cellulose is the portion of the plant structure that comprises the walls of the plant's cells, and is very fibrous and indigestible. Monogastric (single-stomach, non-ruminant) animals do not have the ability to digest cellulose. Rumen microbes, however, produce *cellulase*, the enzyme that breaks down the chemical bonds in cellulose, making it digestible to the microbe and, subsequently, to the ruminant animal.

Another advantage of rumen fermentation is microbial synthesis of important vitamins and amino acids. All the vitamins the animal needs are synthesized by microorganisms, except vitamins A, D, and E. However, animals fed high quality hay or green pasture get their requirement of vitamins A and E. Vitamin D is supplied through exposure to sunlight, which is another advantage of pasture production. Amino acids are the building blocks of protein—a crucial nutrient for growth and reproduction in animals. Rumen microbes synthesize these building blocks from ammonia, a by-product of fermentation in the rumen. Given this fact, even poor quality forage can supply some protein for the grazing animal.

Once it is understood how the rumen works to convert forage to digestible energy and protein, it becomes clear how important grazing animals are to the environment and, in turn, human culture. Grazing animals evolved with the prairies and ranges of the American West, the African steppes, and Mongolia and have contributed to the development of each specific ecological region. Without the ability to harvest plant energy from non-farmlands, humans would miss

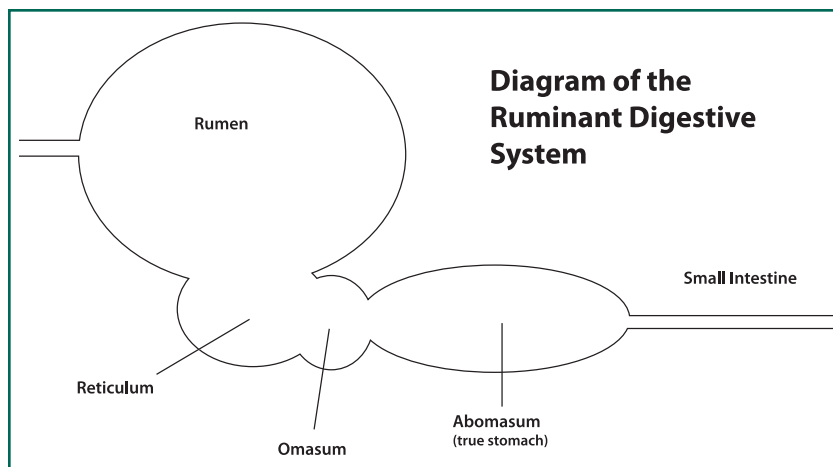

this crucial contribution to the local and world food supply. Grazing animals are the necessary link between forages and people.

## Ruminant Digestive Processes

“Nutrients absorbed from the digestive tract include volatile fatty acids, amino acids, fatty acids, glucose, minerals, and vitamins. These are used in the synthesis of the many different compounds found in meat, milk and wool, and to replace nutrients used for maintaining life processes including reproduction.” (Minson, 1990) Digestion begins when an animal takes a bite from the pasture. As the animal chews the feed is formed into a bolus—a packet of food capable of being swallowed. Saliva is excreted, which further aids in swallowing and serves as a pH buffer in the stomach. Once in the rumen, the feed begins to undergo fermentation. Millions of microorganisms ingest the feed, turning out end products which serve as a major source of nutrients for the animal. Some of the principle products formed are ammonia, methane, carbon dioxide, and *volatile fatty acids* (VFAs). VFAs are absorbed and used as energy by the animal. Ammonia can be absorbed into the animal’s system through the rumen wall, or can be consumed by bacteria to become microbial protein. This microbial protein is then passed through the digestive system to be absorbed in the small intestines.

## Nutrient Requirements of Grazing Livestock

For producers, what are the important nutritional considerations for grazing livestock? This is a good question, since livestock nutritionists have developed a science of nutrient analysis and subsequent ration balancing. But the analyses are built on nutrient content of processed or harvested feedstuffs delivered to ruminants in pens, rather than grazing ruminants selecting a diet from pasture. For this reason, forage nutrient analysis may not be the most reliable method to determine feed quality for grazing livestock.

### Critical Components of Feed Quality

Forage nutrient analysis can be a good tool to determine forage quality. However, forage quality for grazing animals is more accurately determined by the following factors, which are affected by observation and adaptive management of the grazing resource:

- forage intake
- forage diversity
- forage quantity, availability, and density
- appropriate supplementation (energy or protein), when necessary
- appropriate minerals—offered free choice
- and clean, fresh water offered at all times.

## The Basics

The nutritional concern for ruminants centers around energy (i.e., carbohydrates), protein, minerals, vitamins, and water. Energy (carbohydrates) is responsible for maintenance and growth functions of the animal, and for the generation of heat. Protein grows tissue and performs other vital functions. Other nutrients and minerals such as vitamins A and E, calcium, phosphorus, and selenium can be fed “free choice” as a mineral supplement. The following section explores the nutrient requirements of ruminants, beginning with intake.

## Intake

Intake is critically important for acquisition of nutrients by ruminants. Intake is the ingestion of feedstuffs by the animal, and is regulated by the following factors, which are all interrelated:

- palatability
- foraging behavior
- chemical characteristics of the feedstuff
- forage quantity, density, and availability
- dietary energy and fiber content
- physiological stage of the animal
- and temperature

### Related ATTRA Publications

A Brief Overview of Nutrient Cycling in Pastures

Assessing the Pasture Soil Resource

Cattle Production: Considerations for Pasture-Based Beef and Dairy Producers

Dairy Goats: Sustainable Production

Dairy Resource List: Organic and Pasture-Based

Dairy Sheep

Goats: Sustainable Production Overview

Grass-Based and Seasonal Dairying

Managed Grazing in Riparian Areas

Meat Goats: Sustainable Production

Sustainable Sheep Production

Pastures: Going Organic

Pasture, Rangeland, and Grazing Management

Pastures: Sustainable Management

*Palatability* is the flavor and texture of the feedstuff. Ruminants seek sweetness in their feed, probably because sweet is an indicator of soluble carbohydrates, the most critical dietary element for the animal after water. Ruminants will in turn avoid feedstuffs that are bitter, as these often are associated with toxic secondary chemicals.

*Foraging behavior* describes how an animal goes about the grazing process. According to Fred Provenza, range researcher at Utah State University, the study of animal grazing behavior involves understanding:

- food habits and habitat preferences, and
- the effects of nutrients and toxins on preference

“Our work has shown,” he writes, “how simple strategies that use knowledge of behavior can markedly improve the efficiency and profitability of agriculture, the quality of life for managers and their animals, and the integrity of the environment.” (Provenza, 2003) For instance, grazing livestock, unlike closely confined livestock, have the opportunity to graze selectively, and therefore tend to select a diet higher in leaf content than what the overall pasture has to offer. (Minson, 1990) For more information on grazing animal behavior see [www.behave.net](http://www.behave.net) and [www.livestockforlandscapes.com](http://www.livestockforlandscapes.com).

Bite size and bite rate also have an influence on intake. The more dense a pasture sward, the more forage the animal can take in with each bite. Research has shown that a dense, vegetative pasture yielding at least 2,000 pounds of dry matter per acre is adequate for maximizing bite size, and therefore intake. However, when pasture yield drops below 2,000 pounds of dry matter per acre, intake decreases. (Minson, 1990) This exemplifies the fact that the relationship between grazing management, animal behavior, and nutrient uptake is not a simple relation. It is complex and constantly changing, following the changes of the seasons, forage quality, and forage quantity.

*Chemical factors* include nutrients, but also secondary chemicals that are often

**Secondary chemicals** include “plant compound[s] capable of producing toxicosis by impairing some aspect of animal metabolism. Everything is toxic, including oxygen, water, and all nutrients if ingested in high enough doses. Most plants, grasses included, contain toxins. Toxins typically set a limit on the amount of food an animal can ingest. They do not produce harmful effects if ingested in limited amounts. Under certain circumstances, animals have difficulty refraining from overingesting certain plants that contain toxins—the so-called poisonous plants.” (Provenza, 2003)

associated with plant defense. Secondary chemicals are often referred to as toxic substances, but toxicity is really just a matter of degree, of dosage. All plants contain toxic secondary chemicals to some degree, but animals have evolved an innate sense of what is good to eat.

Animals limit the amount of plants they consume that contain secondary chemicals through a feedback mechanism that results in *satiety*, or the feeling that they have had enough. According to Webster, satiety is the “quality or state of being fed or gratified to or beyond capacity, or the revulsion or disgust caused by overindulgence or excess.” When ruminants consume enough of a certain toxic substance, a feedback mechanism induces a switch to an alternative source of nutrients. This is why cattle, sheep, and goats graze more (have higher intake) on a diverse pasture. The variety stimulates their appetite and provides alternative sources when they reach the limit of their first choice of plants.

### Secondary Chemicals in Forages

- Alkaloids in reed canarygrass and lupines
- Tannins in trefoil and lespedeza
- Terpenes in sagebrush and bitterweed
- Endophyte toxin in tall fescue

**A**nimals limit the amount of plants they consume that contain secondary chemicals through a feedback mechanism that results in satiety, or the feeling that they have had enough.

*Forage quantity, density, and availability* directly influence forage intake, and intake is directly related to the density of the pasture sward. Ruminants can take only a limited number of bites per minute while grazing, and cattle in particular will only graze for about 8 hours per day. It is important then to ensure that each bite taken by the grazing animal is the largest bite she can get. A cow grazes by wrapping her tongue around and ripping up forage; sheep and goats use their lips and teeth to select highly nutritious plant parts. Large bites of forage are therefore ensured by maintaining dense pastures.

Dense pastures are those with actively growing and tillering forage plants. Tillering occurs in grasses that are grazed or mowed while vegetative, resulting in the activation of *basal growing points* (clusters of cells that initiate growth near the bottom of the plant) and the growth of new stems and leaves. Tillering results in a plant covering more basal area, which helps make a pasture denser, while protecting the soil.

The length of the grazing period (the time an animal is in a paddock) also has a direct effect on pasture intake. An animal's intake decreases the longer she remains in a given paddock. This happens due to (1) the effect of plant disappearance (as plants are grazed) and subsequent searching by cattle for the next bite, and (2) the decrease in forage crude protein content beginning roughly two days after the animals have been turned in to the paddock. Jim Gerrish has shown that as an animal remains in a paddock, intake and liveweight gains decrease. (Gerrish, 2004) It is for this reason that most dairy graziers move high-producing cattle to new paddocks after each milking.

*Dietary energy and fiber content.* As has been mentioned, livestock eat to the point of *satiety*. Another good definition of satiety is *gastrointestinal satisfaction*. Ruminants possess nutritional wisdom and will select diets high in digestible organic matter, because the most critical nutrients selected by

ruminants are soluble carbohydrates. What an animal actually eats from a pasture is often of higher nutritional quality than the average of the pasture overall. Forages with a dry matter digestibility (DMD) of 60 to 69 percent are considered high quality forages from an energy perspective. Dietary fiber is also a forage quality indicator.

Fiber is necessary for proper rumen function, and is a source of energy as well. However, high levels of fiber in the diet decrease intake. Less digestible forages tend to stay in the animal's digestive system longer (slowing the rate of passage) so the animal remains "full" longer, and subsequently doesn't eat as much. However, the younger a plant is the more soluble carbohydrates it contains, and the less fiber (cell wall components) it contains as well. Younger plants therefore are generally more digestible than mature plants.

*Physiological stage* refers to the stage of life the animal is in, and what level and type of production are being supported. The key physiological stages in the life of ruminant animals are:

- growth (i.e., young lambs, kids, and calves, including feeder animals)
- late pregnancy (very important in sheep and goats)
- lactation (for dairy production or maintenance of offspring)
- and maintenance (such as the cow's dry period)

For example, the peak intake of dairy cattle occurs after peak lactation. Between peak lactation and peak intake, the body must draw on stores to maintain energy balance. Thus dairy animals generally lose body condition during this period. For this reason it is important to ensure high-quality pasture to maintain productivity and optimum health, as well as to ensure the animal's ability to rebreed and enter into lactation at the appropriate time the following season. On the other hand, a dry ewe can gain weight on "fresh air and sunshine"—maintenance requirements are low, and this

**R**uminants possess nutritional wisdom and will select diets high in digestible organic matter, because the most critical nutrients selected by ruminants are soluble carbohydrates.

is the perfect time to let the sheep clean up over-mature forage, with no harm done.

*Temperature* affects the amount of feed an animal needs to maintain its body functions. An animal's metabolic rate increases as the temperature drops below the animal's comfort zone. As temperature drops, more energy is needed to maintain internal heat, so intake increases accordingly. Subsequently, animals typically will not graze as much during hot, humid weather.

### ***Options for Increasing Intake on High Quality Pasture***

High intake is one of the simplest methods of ensuring adequate nutrition for high producing ruminants. Ensure high forage intake by:

- keeping forage in the vegetative stage through grazing management,
- diversifying pasture composition to include several grass species, with around 30 percent of the pasture in legumes, and
- maintaining a dense pasture so animals will take larger bites.

### ***Energy***

Energy is the single most important dietary component for an animal after water. Energy is derived from carbohydrates, fats, proteins, and from the animal's body reserves.

Energy intake maintains body functions and facilitates growth and development, including reproduction and lactation. Energy is supplied to ruminants by highly digestible plant cell contents and a portion of the less digestible plant cell wall fraction. Starches like corn and barley are also high energy sources, and are used extensively in the conventional livestock feeding industry as well as for pasture-based systems where energy supplementation is sometimes useful to enhance production.

Not all the energy taken in by a grazing animal becomes meat, milk, or wool. The hierarchy of energy digestion begins with gross energy, which is the energy of intake. Some of the energy of intake is digestible, and some is not. What is not digestible is excreted as fecal energy, and what is left for use by the body is digestible energy. Metabolizable energy is the energy left after accounting for digestive and metabolism losses. Some of the digestible energy is lost as urine, and some as methane. What is left is energy used for the maintenance of body temperature, respiration, growth, reproduction, and milk production. This fraction is called net energy and is usually split into net energy for maintenance (NE<sub>m</sub>), net energy for gain (NE<sub>g</sub>), and net energy for lactation (NE<sub>l</sub>). Animals can adjust to available energy by putting on fat or by using fat stores. For more information see the box entitled "Body Condition Scoring."

#### **Intake is maximized when pastures are:**

- dense
- digestible
- palatable
- diverse
- correctly stocked
- plentiful (8-10" tall for cattle, 6-8" for sheep)
- familiar to the animal
- fresh (not trampled or heavily manured)



*Good, plentiful pastures assure healthy, productive animals. Photo courtesy of USDA, NRCS.*



*Animals are not productive when pastures are inadequate. Photo courtesy of USDA, NRCS.*

## Body Condition Scoring

Body condition scoring is a method of visually appraising animals to arrive at a qualitative description of nutritional status. Animals must not be too thin or too fat or complications can arise. If too thin, animals may not conceive, may be prone to disease, and usually have reduced milk production. If too fat, animals may experience difficulty giving birth (dystocia).

Body condition scores are ranked on a numerical scale. The lower the number on the scale, the thinner the animal. For sheep and dairy cattle, the scale is from 1 to 5. For beef cattle, the scale is 1 to 9.

### Optimum BCS for Breeding Livestock

Sheep ..... 3.0 to 4.0

Dairy Cattle ..... 2.5 to 3.0

Beef Cattle ..... 4.5 to 5.0

The **Resources** section of this paper lists several publications addressing body condition scores for various species. The publications include charts to assist producers in making visual appraisals of livestock and assigning the appropriate body condition score.

## Protein

“Crude Protein (CP) is calculated from the nitrogen content of the forage. The CP value is important since protein contributes energy, and provides essential amino acids for rumen microbes as well as the animal itself. The more protein that comes from forage, the less supplement is needed. However, most nutritionists consider energy value and intake of forages to be more important than CP.” (Robinson et al, 1998) As has been discussed, the energy value of a forage is best determined by forage maturity, density, and availability. Protein in forages is most correlated with forage maturity, as more mature forages have a lower percentage of crude protein.

Cattle require two types of protein in their diet. One type is degraded in the rumen and is used to meet the needs of the microbial population, and the other bypasses the rumen and is used primarily to meet the productive needs of the animal.

Energy Partitioning. From USDA, 2003.

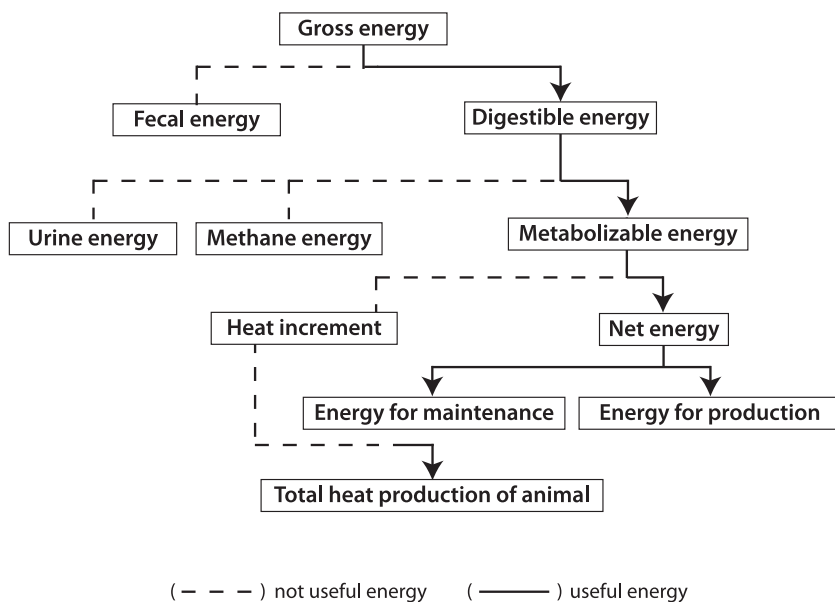

When protein is degraded in the rumen it is called *rumen degradable protein*. Rumen degradable protein is essentially food for rumen bacteria. When the microbes die they are passed through to the stomach and small intestines where they are digested by the animal. The resulting microbial protein is then absorbed into the animal’s bloodstream. Some of the protein in the diet does not undergo degradation in the rumen, but passes straight to the abomasum or stomach for digestion. When protein escapes rumen breakdown and passes to the stomach it is referred to as *rumen undegradable protein* or *bypass protein*.

Protein Flow.

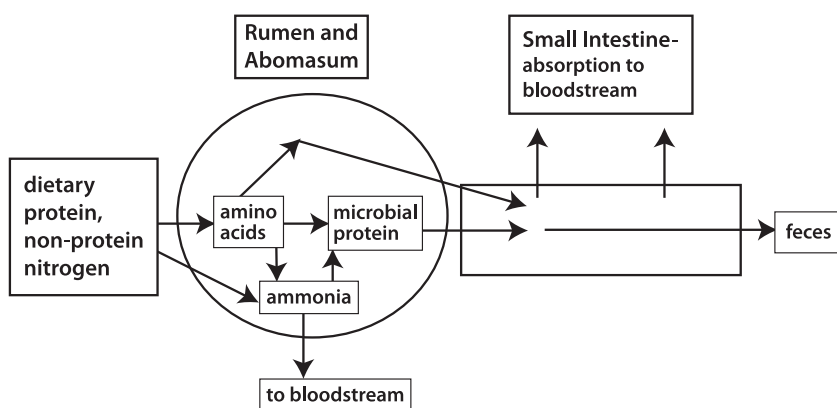



**V**itamins are important for the formation of catalysts and enzymes that support growth and body maintenance in animals.

Bypass protein is important because a large percentage of the rumen degraded protein is absorbed as ammonia and, if in high concentrations, can be lost through the urine as urea. In high-producing animals this represents an inefficient utilization of protein, so increasing the amount of protein that is bypassed to the intestines constitutes a more efficient utilization of protein for growing or lactating animals on high-quality pastures. In forages, roughly 20 to 30 percent of the protein taken in by the animal is bypassed to the intestines. Lactating or growing cattle generally require 32 to 38 percent of their total protein intake to be in the undegradable form. (Muller, 1996) High-quality pastures can meet almost all the needs of high-producing livestock. For those animals that require supplementation, corn, cottonseed and linseed meals, brewers dried grains, corn gluten meal, distillers dried grains, and fish meal are typically high in bypass protein.

The microbial degradation of protein is an energy-dependant process. Carbohydrates are the energy-yielding nutrients in animal nutrition and are supplied by the production of volatile fatty acids in the rumen. Generally more microbial protein is synthesized from green forage diets than from hay or mature forage diets. When a ruminant animal grazes fresh forage on high-quality pasture, about 70 percent of the protein is degraded in the rumen by microorganisms, and about 30 percent escapes to the small intestine for absorption. Ruminant animals need approximately 65 to 68 percent of the protein to be rumen degradable for adequate rumen function and the development of microbial protein. But if more protein is degraded in the rumen, less is available to the animal for absorption in the small intestine. This is important because researchers believe that rumen undegradable or bypass protein consists of certain essential amino acids that are missing or deficient in rumen degradable protein. Much of the rumen degraded protein is absorbed as ammonia and excreted out of the body via the urine, and is therefore a waste of protein. This is why bypass or undegradable protein is

important, especially for high-producing livestock such as dairy animals, even in protein-rich-pasture diets.

Some animal nutritionists suggest that bypass protein has been overemphasized. This is because the total proportion of bypass protein in most forages is around 30 percent, which is very close to the requirements of the ruminant animal. In this case, they suggest, feeding the rumen microorganisms takes on particular importance, for if the rumen microorganisms are healthy, they will supply the ruminant with the nutrients they need to maintain body functions and remain productive. We must remember that ruminant animals evolved in symbiosis with rumen microorganisms in a grassland environment, and they are inherently adapted to this function.

### ***Minerals and Vitamins***

The principle minerals of concern for livestock on growing forages are calcium and magnesium. Others to consider are salt, phosphorus, potassium, and sulfur. These minerals are very important for cellular respiration, nervous system development, protein synthesis and metabolism, and reproduction. Mineral supplements are available in many formulations. Because soils differ in mineral content from place to place, it is difficult to recommend a mineral mix that works in all places, although most animal scientists suggest at the very least a mineral mix with a calcium to phosphorus ratio of 2:1. Consider using a loose mineral mix fed free choice rather than mineral blocks for cattle on lush spring or small grain pasture to avoid grass tetany (hypomagnesemia) and to ensure the animals are getting enough mineral.

Vitamins are important for the formation of catalysts and enzymes that support growth and body maintenance in animals. Green growing plants contain carotene, which is a precursor to vitamin A. If ruminants are on green forage (including green hay) vitamin A should not be deficient. Vitamin A deficiencies occur when ruminants are placed on concentrate feeds, or when fed dry,

stored forage during the winter. B vitamins are synthesized by rumen microorganisms so supplementation is not necessary. Vitamin D is synthesized in the skin from exposure to sunlight, so Vitamin E is the only other vitamin of concern that sometimes requires supplementation.

Mineral and vitamin supplementation is very important to maintain herd health, and careful attention must be paid in developing a mineral and vitamin supplementation plan. Keep these things in mind when feeding these supplements to livestock:

1. Keep mineral mixes dry. Wet mineral is unpalatable and is known to lose some of its efficacy when damp.
2. Monitor consumption to make sure it's always available. Keep the feeders full.
3. Don't forget that some animals display social dominance. Older, more dominant animals will often eat more than their share of mineral mix. Remedy this by having more than one feeder, separated into different parts of the pasture.

### Sheep and Copper Toxicity

Sheep are very sensitive to copper. If you have cattle and/or goats, and sheep on the same farm it is extremely important to supply them with different mineral mixes, as a mix that is formulated for cattle or goats will likely be lethal for sheep. Loose mineral mixes are better than blocks for sheep and goats.

Check with your local Extension agent or veterinarian to determine the mineral and vitamin mixes and recommendations common to your area.

### Water

Sheep and goats require one gallon of water per day for dry ewes, 1.5 gallons per day for lactating ewes, and 0.5 gallons per day for finishing lambs. Water consumption will increase during the heat of the summer, and when the animals are grazing or browsing plants with high concentrations of secondary,



Photo courtesy of USDA, NRCS.

toxic chemicals. Examples are knapweed, sagebrush, and scotchbroom.

Cattle require from 3 to 30 gallons of water per day. Factors that affect water intake include age, physiological status, temperature, and body size. A rule of thumb is that cattle will consume about one gallon of water per 100 pounds of body weight during winter and two gallons per 100 pounds of body weight during hot weather. In general, you can easily double the estimates for lactating cattle. Water should be clean and fresh, as dirty water decreases water intake. It is good to remember that all other nutrient metabolism in the body is predicated on the availability of water, and if an animal stops drinking, nutrient metabolism (which results in growth and lactation) will decrease.

## Forage Resources and Grazing Nutrition

Nutrient content of forages varies with plant maturity. As the plant matures, it shunts sugars and proteins to the reproductive centers of the plant, namely the seed (in the case of annuals) and the roots (in the case of perennials). Plant maturity results in more fibrous, and less digestible, leaves and stems. Various circumstances affect plant maturity. Among the most common

factors contributing to plant maturity and subsequent forage quality are:

- length of growing season (plants mature faster in shorter growing seasons)
- moisture availability (moisture stress reduces photosynthetic activity and initiates dormancy)
- pasture plant species composition (some species remain vegetative longer than others)
- and the grazing system

Of these factors, the one that livestock managers have the most control over is the grazing system. Controlled defoliation and adequate rest are crucial for plants to remain vegetative, and therefore more nutritious, during the growing season. This topic is summarized in the **Grazing Management** section of this publication and covered in detail in the ATTRA publications *Pasture, Rangeland, and Grazing Management*, *Rotational Grazing*, and *Pastures: Sustainable Management*.

### **Plant Type, Species, and Nutritional Quality on Native Range**

There are three basic plant types commonly found in pastures, and each has its place in animal nutrition. These plant types are:

- Grasses
- Shrubs
- Forbs

Grasses tend to be high in nutrients in the spring, and begin to decline as the growing season progresses. By the time winter sets in, rangeland grasses such as rough fescue and bluebunch wheatgrass will have

relatively high TDN levels and protein compositions of 5 percent. (Ricketts, 2002) Shrubs tend to have their highest nutrient content in the spring as well, but generally retain a higher nutrient content throughout the growing season and into the dormant period. Most shrubs, such as greasewood and saltbush carry a protein content of greater than 12 percent in the winter. Forbs are high in protein as well. Purple prairie clover and dotted gayfeather have as much or more protein, when green, than alfalfa and clover. “These forbs are like little protein blocks scattered on the landscape.” (Ricketts, 2002)

**Grasses.** Grasses are divided into two types: warm season and cool season. On semi-arid prairies and western ranges, warm season grasses do most of their growing from May to August, whereas cool season grasses do their growing from March to June. Knowledge of which grasses are in your pastures will help you to decide when to graze them to take advantage of highest nutrient content. In the spring, grasses will have a protein content of approaching 20 percent and will be around 10 percent protein when in mid-bloom, or when half the plants have developed a seedhead.

On deteriorated dry western range sites, you might see a proliferation of Kentucky bluegrass, bottlebrush squirreltail, and cheatgrass. The weedy grasses can be good in nutrient value, but generally do not produce enough annual forage to meet the needs of grazing livestock, and are often vegetative for a very short period of time, as with cheatgrass and squirreltail. Broadleaf weeds become coarse and unpalatable very soon after they begin to mature. Pastures that have greater than about 50 percent of these plants should be considered for a serious revision of the grazing system, or pasture renovation if appropriate. Consider multi-species grazing, because sheep and goats may eat the weeds that cattle do not, thus bringing the pasture back in balance.

**Shrubs.** Shrubs are very good to have on native range because they are high in protein for a greater part of the year. Many

<b>Feeding Value of Forages</b>			
	<b>TDN %</b>	<b>Crude Protein %</b>	
		Grass	Legume
Vegetative	63	15	21
Boot or bud	57	11	16
Bloom	50	7	11
Mature	44	4	7

*Adapted from Fisher, 1980*

livestock and wildlife find these plants important for getting them through the winter. Shrubs on many western ranges include winterfat, sagebrush, fringed sagewort, four-wing saltbush, snowberry, and rabbitbrush. These plants will generally have more than seven percent protein content through the winter. Combined with other dormant forages, these plants can often supply an animal with its maintenance needs for protein if there are enough plants.

Cattle are typical grazers, and utilize grass as their primary food source. They will, much like goats and sheep, browse on winterfat and saltbush. A range site with 20 to 30% of its cover in a diverse population of shrubs serves to sustain all classes and species of livestock as well as provide winter food and cover for wildlife.

*Forbs.* Forbs, or non-woody broadleaf plants, are generally higher in protein than grasses. Many forbs are considered weeds, but most are often palatable and nutritious when immature. Typical rangeland forbs that are high in protein and digestibility include gayfeather, western yarrow, prairie clover, and Indian paintbrush. On dryland ranges, high-dormancy alfalfa can make a very good supplement for livestock, as do birdsfoot trefoil and cicer milkvetch, which in addition to being high-quality forage, have anti-bloat characteristics as well.

### ***Plant Type and Species on Temperate Pasture***

Grasses and forbs generally dominate shrubs in temperate regions. On temperate pastures, warm season grasses exhibit growth from as early as March to as late as September, and cool season grasses grow well from October into June, with reduced growth during the winter months. Indicators of poor pasture condition on temperate pastures are grasses such as sandbur, rattail smutgrass, and little barley, and broadleaf weeds like curly dock, croton, and hemp sesbania.

The most common forbs used on temperate pastures include clovers, alfalfa, and vetches. White clover, hairy vetch, red clover, or

## **A Case for Species Diversity**

As shrubs and forbs typically have higher protein concentrations than most grasses, why are they generally considered substandard as livestock forage? The main reason is that most shrubs and many forbs contain secondary chemicals that are often toxic to grazing animals. Animals grazing sagebrush, for example, will very quickly get their fill as the level of alkaloids accumulates in their systems. However, livestock display nutritional wisdom and often eat small portions of various species in order to (1) obtain essential nutrients, and (2) neutralize the effects of more toxic plant species.

Berseem clover are often overseeded into warm season pastures with annual ryegrass or small grains in the humid South to supply high quality winter pasture to cattle from October through April. Some excellent warm season legumes to consider in temperate regions are annual cowpeas and perennial peanuts. Turnips also make an excellent season extension annual crop for providing high-quality grazing into the fall in some temperate regions. For more information on alternative forages to extend the grazing season, see the ATTRA publication *Pasture, Rangeland, and Grazing Management* at [www.attra.ncat.org](http://www.attra.ncat.org) or call the ATTRA help line at 1-800-346-9140.

## **Matching Nutritional Requirements of Livestock to the Forage Resource**

One of the most important questions a livestock manager can ask is “what do I need to know in order to match the nutritional requirements of my animals to the forage resource?” To answer this question with the highest level of certainty, the producer should perform the following crucial management tasks:

- inventory available forage resources (documenting re-growth, crop residue, etc.)
- prioritize grazing of highest quality pastures by animals with highest nutrient requirements (growing, lactating)
- observe and determine the forage growth curve for your pastures

- coincide the forage growth curve with peak animal demand
- monitor to ensure animal numbers and type are appropriate to forage resource

### **Forage Growth Phases**

Forage supply is not continuous throughout the year. You can expect anywhere from three to nine months of growing season, and three to nine months of dormancy, depending on the region. Cool-season pasture growth begins in the early spring and quickly produces very large amounts of forage, then tapers off toward mid-summer. Given adequate moisture, cool-season pastures will often produce a second surge of growth in the fall before going dormant.

Warm-season pasture begins later in the spring and continues into early autumn when day length shortens and temperatures fall. Warm-season pastures complement cool-season pastures nicely by providing forage when cool-season growth wanes in mid-summer. A diverse mix of cool- and warm-season pastures benefits livestock managers by overlapping the growth curves of both types, meaning more high-quality pasture than otherwise.

### **Peak Animal Demand**

The highest nutrient demand for beef cattle is one to three months after parturition

(birth) and lowest demand is three to four months before parturition. (Gerrish, 2004) For sheep, just before lambing to weaning are crucial times when nutrient requirements are highest, especially just prior to lambing. For dairy animals, the entire lactation period is critical. Knowing the forage growth curve for your pastures will allow you to match forage growth with animal demand. For example, consider having ewes lamb when grass is at optimum productivity and when the ewes need it the most. On the other hand, think about the needs of young stock. Unless you are selling at weaning, you need a plan for high-quality pasture for young growing animals.

### **Supplementing Protein or Energy: When is it Necessary?**

Cattle, sheep, and goats, by nature grazing and browsing animals, grow and reproduce well on pasture alone. However, an intensive and industrial agricultural production philosophy has dictated that crops and animals should be raised faster, larger, and more consistently than a pasture system can deliver. Thus confinement systems with delivered forages and concentrated feeds have been the norm since the 1950s. Raising animals on grass is slower than raising animals on grain. However, a pasture-based livestock producer will, with careful planning, realize cost savings and subsequent profitability through the efficiency of relying on the natural systems of nutrient cycling, biological pest controls, and perennial pasture productivity.

The major operational expense confronting the livestock industry in most parts of the United States is for supplemental feed. In temperate regions of the country that experience adequate rainfall and a lengthy grazing season, supplementation on green, growing, vegetative, well-managed pastures should not be necessary. However, young and lactating stock require more energy and protein than mature, non-lactating animals.

Well-managed grass-legume pastures can be highly digestible with protein concentrations approaching 25 percent while



*District Conservationist Rhonda Foster and Grasslands management Specialist Ralph Harris discuss intensive grazing rotations at a farm in Benton County, Georgia. The producer grazes his cattle on a 3 week rotation. Photo courtesy of USDA, NRCS.*

vegetative. These pastures can supply the nutrients needed to raise lambs, kids, heifers, or steers, or support lactating cattle, sheep, or goats. The problem on high-quality pastures often becomes one of inefficient protein use. Supplementing energy with digestible fiber in these situations can make the animals utilize protein more efficiently. Digestible fiber (energy) sources include wheat middling (a coproduct of wheat processing sometimes called midds), soybean hulls, corn gluten feed, and whole cottonseed. (Jackson, undated)

Corn is grown on many small diversified farms, in rotation with pasture, legumes, or vegetables, as animal feed, and is an excellent source of low-fiber energy for grazing ruminants. However, if corn is fed in high quantities, forage intake will decline. A pound or two a day for sheep and goats and five or six pounds per day for cattle will generally provide enough supplemental energy without decreasing forage intake. Limiting corn supplementation to no more than 0.5 to 1.0 percent of body weight per day is recommended for cattle on pasture. (Sewell, 1993)

### When to Supplement

- Supplementing energy is helpful on vegetative, well-managed pastures for more efficient utilization of forage protein (for high producing animals).
- Supplementing with protein is necessary on low-quality pasture and rangeland or when continuously grazing temperate warm-season pastures.

When supplementing ruminants on pasture, consider the following questions:

- Will the added production cover the expense, especially if the feed is shipped from off the farm?
- Is there an inexpensive local source of protein?
- Do you raise the feed on the farm?
- Do you have necessary harvest, storage, and feeding equipment?

Remember:

- Substitution effect—forage intake decreases with less fibrous, more digestible supplements like corn.
- Supplementation of protein on low-quality forages will increase forage intake, and therefore increase energy intake.

### Concept of First Limiting Nutrient

Determine which nutrient is limiting and supplement that one first. For instance, degradable intake protein requirements need to be met for microbial growth first. Then and only then consider bypass protein supplementation, and only if it is deficient. Likewise, if energy is deficient, protein supplementation will be wasteful and expensive.

Remember: on high-quality pastures, energy is often the limiting nutrient. Digestible fiber feeds are good for ruminants on high quality forage because they do not reduce intake, and provide energy for protein metabolism. Examples are: corn gluten feed (corn gluten meal plus the bran), wheat midds (screenings from wheat flour processing), and whole cottonseed.

### Feeding Cottonseed Products to Cattle

Three types of cottonseed products are typically fed to beef and dairy cattle. These are *whole cottonseed* with lint, *cottonseed meal*, and *cottonseed hulls*. Whole cottonseed is a very good source of protein for cattle. However, whole cottonseed contains a chemical called *gossypol* that can inhibit the reproductive performance of breeding cattle, particularly bulls. For this reason it is recommended that producers limit whole cottonseed supplementation to calves at 1.5 pounds per day, stocker cattle at no more than 3 pounds per day, and mature cows at 5 pounds per day. Avoid feeding whole cottonseed to bulls.

## Forage Sampling and Production (Yield) Estimates

If you choose to have your forage analyzed for nutrient content, the key nutrients to consider are crude protein (CP) and total digestible nutrients (TDN). Acid detergent fiber (ADF) and neutral detergent fiber (NDF) are useful as well for determining energy content. ADF and NDF measure fiber, or cell wall contents. The higher the fiber the lower the energy value is for a feedstuff.

## Your Local Cooperative Extension Office

Contact your local Cooperative Extension office for information on poisonous plants, forage analysis, and locally adapted forages. The USDA maintains an online database of local Cooperative Extension offices on its website at [www.csrees.usda.gov/Extension/index.html](http://www.csrees.usda.gov/Extension/index.html). You will also find the phone number for your Cooperative Extension office in the county government section of your telephone directory.

## Grazing Management

Grazing management is the regulation of the grazing process by humans through the manipulation of animals to meet specific, predetermined production goals. (Briske and Heitschmidt, 1991) The primary considerations of grazing management are:

- temporal distribution of livestock (time)
- spatial distribution of livestock
- kind and class of livestock
- and number of livestock (Heitschmidt and Taylor, 1991)

If given a choice, livestock will only eat the highest quality, most palatable plants in a pasture. In order to ensure that plant biodiversity is maintained in the pasture it is necessary to set up a grazing management system to better control livestock grazing. The elements of grazing to control are timing and intensity of grazing. This means controlling the number of animals and how long they are in a pasture.

Rotational grazing systems take full advantage of the benefits of nutrient cycling as well as the ecological balance that comes from the relationships between pastures and grazing animals. High density stocking for short periods helps to build soil organic matter and develops highly productive, dense, resilient pastures.

Some other measurements to consider in managing livestock grazing include:

Although determined by a system that relies on harvested forages, these two measures will give the producer a good starting point to make decisions about supplementation. For cattle, forage with 10 to 13 percent CP and 55 to 60 percent TDN will meet all the needs of most classes of livestock. Growing and lactating livestock need added protein and energy if the forage resource is not of adequate quality. Also important is mineral content. Different soils in different areas of the country can be deficient in different nutrients. Selenium and copper availability are a problem in the southeast and northwest, for instance. Check with your Cooperative Extension office or state Extension forage or beef specialist to determine the mineral needs in your area.

Estimating forage yield in a pasture also plays a very important role in developing a nutrition plan for grazing livestock. There are many ways to estimate forage yield, from the more time-consuming clip-and-weigh approach to more generalized estimates from plant height and density. The ATTRA publication *Pasture, Rangeland, and Grazing Management* includes formulas and instructions for estimating forage yield and developing an appropriate stocking rate.

## Plant Toxicity and Grazing-Related Disorders

Graziers must pay careful attention to the negative health effects that certain plants can cause in livestock. Plant toxicosis occurs either through the ingestion of (1) poisonous plants or (2) forage plants that contain toxic substances due to environmental or physiological conditions. Plant poisoning can be significantly reduced by proper grazing management. Poisonous plants contain resins, alkaloids, and/or organic acids that render them unpalatable. If the pasture contains enough good forage, there is little reason for the animals to select bad-tasting plants. The ATTRA publication *Pasture, Rangeland, and Grazing Management* contains detailed information on plant toxicity and grazing-related disorders. In addition, your local Cooperative Extension office has information on poisonous plants in your area.

**G**razing management is the regulation of the grazing process by humans through the manipulation of animals to meet specific, predetermined production goals.

- forage density
- after-grazing plant residue
- paddock rest time
- range condition and trend,
- animal body condition, health, and physiological stage
- grazing systems, including stocking rate and stock density
- and pasture and rangeland monitoring

These considerations are covered extensively in other ATTRA publications. For more information on grazing management see the ATTRA publications *Pasture, Rangeland, and Grazing Management; Rotational Grazing;* and *Paddock Design, Fencing, and Water Systems for Controlled Grazing.*



Photo courtesy of USDA, NRCS.

## References

- Ball, D.M., C.S. Hoveland, and G.D. Lacefield. 1991. Southern Forages. Potash and Phosphate Institute, Norcross, GA.
- Beetz, A. 2002. A Brief Overview of Nutrient Cycling in Pastures. ATTRA: Fayetteville, AR.
- Briske, D.D. and R.K. Heitschmidt. 1991. An Ecological Perspective, in *Grazing Management: An Ecological Perspective*, R.K. Heitschmidt and J.W. Stuth, eds. Timber Press, Portland, OR.
- Cheeke, Peter R. 1991. *Applied Animal Nutrition: Feeds and Feeding*. MacMillan Publishing Company, New York.
- FAO: Food and Agriculture Organization of the United Nations. 2002. *FAO Statistics*.
- Gerrish, J. 2004. *Management-Intensive Grazing: The Grassroots of Grass Farming*. Ridgeland, MS: Green Park Press.
- Heitschmidt, R.K. and Taylor, C.A. 1991. Livestock Production, in *Grazing Management: An Ecological Perspective*, R.K. Heitschmidt and J.W. Stuth, eds. Timber Press, Portland, OR.
- Holecheck, J.L., R.D. Pieper, and C.H. Herbel. 1989. *Range Management, Principles and Practices*. Regents/Prentice Hall, Englewood Cliffs, NJ.
- Jackson, K. No date. *Choosing the Right Supplement*. Klopfenstein, Terry. 1996. Need for escape protein by grazing cattle. *Animal Feed Science Technology* 60: 191-199.
- Lalman, David. 2004a. *Supplementing Beef Cows*. OSU Publication F-3010. Oklahoma State University Extension Service. <http://pods.dasnr.okstate.edu/docushare/dsweb/Get/Document-900/F-3010pod.pdf>
- Lalman, David. 2004b. *Vitamin and Mineral Nutrition of Grazing Cattle*. OSU Publication E-861. Oklahoma State University Extension Service. <http://pods.dasnr.okstate.edu/docushare/dsweb/Get/Document-2032/E-861web.pdf>
- New Zealand Society of Animal Production. 1987. *Livestock Feeding on Pasture*, A.M. Nicol, ed. Occasional Publication No. 10. Hamilton, New Zealand.
- Mathis, C.P. 2003. *Protein and Energy Supplementation to Beef Cows Grazing New Mexico Rangelands*. Circular 564. New Mexico State University Cooperative Extension Service.
- Merck & Co., Inc. 2006. *Merck Vet Manual*, 9th Edition. Cynthia M. Kahn, ed. Whitehouse Station, NJ. [www.merckvetmanual.com/mvm/index.jsp](http://www.merckvetmanual.com/mvm/index.jsp)
- Minson, Dennis J. 1990. *Forage in Ruminant Nutrition*. Academic Press, Inc., NY.



Muller, L. D. 1996. Nutritional Considerations for Dairy Cattle on Intensive Grazing Systems. Proceed-ings from the Maryland Grazing Conference.

Newman, Y.C., M.J. Hersom, C. G. Chambliss and W. E. Kunkle. 2007. Grass Tetany in Cattle. Florida Cooperative Extension Service, Institute of Food and Agricultural Sciences, University of Florida. <http://edis.ifas.ufl.edu/DS137>

Provenza, Fred. 2003. Foraging Behavior: Manag-ing to Survive in a World of Change. Logan, UT: Utah State University. [www.behave.net](http://www.behave.net)

Ricketts, Matthew. 2002. Feed Less, Earn More. Mon-tana GLCI Fact Sheet.

Robinson, Peter, Dan Putnam, and Shannon Mueller. 1998. Interpreting Your Forage Test Report, in Cali-fornia Alfalfa and Forage Review, Vol 1, No 2. Univer-sity of California.

Savory, Allen and Jody Butterfield. 1998. Holistic Management: A New Framework for Decision Making (2nd edition). Washington, DC: Island Press.

Sewell, Homer. 1993. Grain and Protein Supplements for Beef Cattle on Pasture. University of Missouri Extension.

USDA. 2003. National Range and Pasture Handbook. Fort Worth: Natural Resources Conservation Service, Grazing Lands Technology Institute. [www.glti.nrcs.usda.gov/technical/publications/nrph.html](http://www.glti.nrcs.usda.gov/technical/publications/nrph.html)

Weiss, Bill. 1993. Supplementation Strategies for Intensively-Managed Grazing Systems. Presentation at the Ohio Grazing Conference, March 23, Wooster.

## Resources

---

Some of the resources listed below are Web-based documents and programs. If you do not have Inter-net access at home, contact your local public library. Many libraries have free Internet computers and training for their patrons.

### **General Ruminant Nutrition and Body Condition Score**

Beef Cattle Nutrition Workbook, EM 8883-E. Decem-ber 2004. Oregon State University Extension. <http://oregonstate.edu/Dept/EOARC/about/home/scientists/documents/DWB26.pdf>

Beginner's Guide to Body Condition Scoring: A Tool for Dairy Herd Management. Penn State University. [www.das.psu.edu/dairynutrition/documents/363eng.pdf](http://www.das.psu.edu/dairynutrition/documents/363eng.pdf)

Body Condition Scoring Beef Cows. Virginia Cooperative Extension. [www.ext.vt.edu/pubs/beef/400-795/400-795.html](http://www.ext.vt.edu/pubs/beef/400-795/400-795.html)

Body Condition Scoring of Sheep. Oregon State Uni-versity. <http://extension.oregonstate.edu/catalog/pdf/ec/ec1433.pdf>

Church, D.C., (editor). 1993. The Ruminant Animal: Digestive Physiology and Nutrition. Waveland Press. ISBN: 0881337404. (Order online from [www.amazon.com](http://www.amazon.com)).

Langston University, Agricultural Research and Exten-sion Programs. Goat Nutrient Requirement Calculators. [www2.luresext.edu/goats/research/nutr\\_calc.htm](http://www2.luresext.edu/goats/research/nutr_calc.htm)  
Nutrient Requirements for Goats  
[www2.luresext.edu/GOATS/research/nutreqgoats.html](http://www2.luresext.edu/GOATS/research/nutreqgoats.html)

Maryland Small Ruminant Page: Feeding and Nutrition. [www.sheepandgoat.com/feed.html](http://www.sheepandgoat.com/feed.html)

Penn State University Dairy Cattle Nutrition  
[www.das.psu.edu/dairynutrition](http://www.das.psu.edu/dairynutrition)

University of Wisconsin-Madison, Dairy Science Department. Dairy Nutrition. [www.wisc.edu/dysci/wwex/nutritn/nutritn.htm](http://www.wisc.edu/dysci/wwex/nutritn/nutritn.htm)

### **Nutritional Requirements of Cattle, Sheep, and Goats**

National Research Council. 1996. Nutrient Requirements of Beef Cattle: Seventh Revised Edition, Update 2000. National Academy Press, Washington, DC.

National Research Council. 2001. Nutrient Requirements of Dairy Cattle: Seventh Revised Edition. National Academy Press, Washington, DC.

National Research Council. 1981. Nutrient Requirements of Goats. National Academy Press, Washington, DC.

National Research Council. 1985. Nutrient Requirements of Sheep, Sixth Revised Edition. National Academy Press, Washington, DC.

*The preceding four resources can be downloaded as PDF files for free from the National Academies Press website at [www.nap.edu](http://www.nap.edu) or by contacting:*

*The National Academies Press  
500 Fifth Street NW  
Lockbox 285  
Washington, DC 20055  
(888) 624-8373*

### ***Estimating Forage Production***

Barnhart, Stephen. 1998. Estimating Available Pasture Forage, PM 1758. Iowa State University Extension. [www.extension.iastate.edu/Publications](http://www.extension.iastate.edu/Publications)

Brence, L. and R. Sheley, 1997. Determining Forage Production and Stocking Rates: A Clipping Procedure for Rangelands, MT199704AG. Montana State University Extension. [www.montana.edu/wwwpub/pubs/mt9704.html](http://www.montana.edu/wwwpub/pubs/mt9704.html)

Gerrish, Jim. 2004. Forage Supply: The Grazier's Checking Account, in Management-intensive Grazing: The Grassroots of Grass Farming. Ridgeland, MS: Green Park Press.

Pratt, W. and G.A. Rasmussen. 2001. Calculating Available Forage, NR/RM/03. Utah State University Extension. [http://extension.usu.edu/files/publications/publication/NR\\_RM\\_03.pdf](http://extension.usu.edu/files/publications/publication/NR_RM_03.pdf)

### ***Grazing Management***

Blanchet, K., H. Moechnig, and J. DeJong-Hughes. 2003. Grazing Systems Planning Guide. St. Paul, MN: University of Minnesota Extension Service Distribution Center. [www.extension.umn.edu/distribution/livestocksystems/DI7606.html](http://www.extension.umn.edu/distribution/livestocksystems/DI7606.html)

McCrary, Lisa and Charlotte Bedet. 2007. Organic Livestock and Grazing Resources, Updated January

2007. Columbus, OH: OEFFA. [www.oeffa.org/documents/OrganicLivestockDirectory2007.pdf](http://www.oeffa.org/documents/OrganicLivestockDirectory2007.pdf)

Ohlenbusch, P.D., and S.L. Watson. 1994. Stocking Rate and Grazing Management, MF-1118. Kansas State University Extension. [www.oznet.ksu.edu/library/crpsl2/MF1118.pdf](http://www.oznet.ksu.edu/library/crpsl2/MF1118.pdf)

Pratt, W. and G.A. Rasmussen. 2001. Determining Your Stocking Rate, NR/RM/04. Utah State University Extension. [http://extension.usu.edu/files/publications/publication/NR\\_RM\\_04.pdf](http://extension.usu.edu/files/publications/publication/NR_RM_04.pdf)

Provenza, Fred. 2003. Foraging Behavior: Managing to Survive in a World of Change. Logan, UT: Utah State University. [www.behave.net](http://www.behave.net)

USDA. 2003. National Range and Pasture Handbook. Fort Worth: Natural Resources Conservation Service, Grazing Lands Technology Institute. [www.glti.nrcs.usda.gov/technical/publications/nrph.html](http://www.glti.nrcs.usda.gov/technical/publications/nrph.html)

The Stockman Grass Farmer Magazine  
234 W School Street  
Ridgeland, MS 39157  
800-748-9808

[www.stockmangrassfarmer.net/index.html](http://www.stockmangrassfarmer.net/index.html)

*A publication devoted to the art and science of grassland agriculture.*

## **Notes**

**Ruminant Nutrition for Graziers**

By Lee Rinehart  
NCAT Agriculture Specialist  
©2008 NCAT

Paul Driscoll, Editor  
Amy Smith, Production

This publication is available on the Web at:  
[www.attra.ncat.org/attra-pub/ruminant.html](http://www.attra.ncat.org/attra-pub/ruminant.html)  
or  
[www.attra.ncat.org/attra-pub/PDF/ruminant.pdf](http://www.attra.ncat.org/attra-pub/PDF/ruminant.pdf)

IP318  
Slot 52  
Version 030308



[www.attra.ncat.org](http://www.attra.ncat.org)

## CURRENT TOPIC

By Linda Coffey  
NCAT Agriculture Specialist  
June 2001

### *Benefits of Multispecies Grazing*

Mixed-species grazing has several advantages. Cattle prefer grass over other types of plants, and are less selective when grazing than sheep or goats. Sheep and goats, on the other hand, are much more likely to eat weeds. Sheep prefer forbs (broad-leaved plants) to grass, and goats have a preference for browsing on brush and shrubs, and then broad-leaved weeds. Therefore, grazing cattle, sheep, and goats together on a diverse pasture should result in all types of plants being eaten, thus controlling weeds and brush, while yielding more pounds of gain per acre compared to single-species grazing. (1).

The addition of goats to cattle pastures has been shown to benefit the cattle by reducing browse plants and broad-leaved weeds. This permits more grass growth. Goats will control blackberry brambles, multiflora rose, honeysuckle, and many other troublesome plants (2). It is thought that you can add one goat per cow to a pasture without any reduction in cattle performance, and with time the weedy species will be controlled so that total carrying capacity is improved. This is a cheap way of renovating pastures, and you can sell the extra goats and kids for a profit, as well. The same principle holds for sheep. Although they are less likely to clean up woody plants, sheep are quite effective at controlling other weeds, with proper stocking pressure.

Multispecies grazing may also benefit pastures that are less diverse, by encouraging more even grazing. Cattle will tend to graze taller grasses that sheep may reject. It has been shown that sheep graze near cattle manure deposits, which cattle avoid (3); this too results in more even use of the pasture. Carrying capacity and pasture productivity are improved, and animal gains are also increased (4, 5, 6). Diversification of species results in diversification of income sources (7). Also, some researchers have found that adding cattle to a sheep flock may help reduce predation losses, after a period of bonding (8).



**Cows prefer grass; sheep prefer forbs; goats prefer trees and shrubs. Nevertheless, there is regular crossover among the three types of feeders.**

Illustration by Elayne Sears. Reproduced from *Small-Scale Livestock Farming* by Carol Ekarius, published by Storey Communications. Used with permission.



Another way that multispecies grazing can improve pasture and animal production is through the consumption of poisonous plants by a species that is not harmed by the toxins. For example, leafy spurge and larkspur – serious problems in the western states – are harmful to cattle, but not to sheep. Therefore, using sheep to eliminate those plants will result in more useable and safe pasture for cattle (9). Conversely, some plants are problematic for sheep, but easily tolerated by cattle (10).

**Caution:** Check with a veterinarian or county extension agent about weed identification. The following websites may be helpful for learning about toxic plants:  
<http://cal.nbc.upenn.edu/poison/>  
<http://vet.purdue.edu/depts/addl/toxic/cover1.htm>  
<http://www.library.uiuc.edu/vex/toxic/scilist.htm>  
<http://www.ansci.cornell.edu/plants/plants.html>

Parasites are a major concern with sheep and goats, under any system. Worm eggs are deposited on the pasture in the manure; the eggs hatch and larvae are consumed by grazing animals. If left untreated, concentrations of parasites will increase with time as this cycle is repeated. Higher concentrations of animals on a pasture may tend to magnify the infestation. Parasites are species-specific; that is, cattle parasites affect cattle, and not sheep, while sheep parasites affect sheep but not cattle. The cattle act as “vacuum cleaners”, ingesting the sheep worm larvae, and preventing them from affecting the sheep. This is most helpful when sheep and cattle follow each other in a grazing system. However, goats and sheep do share parasites, and therefore grazing them together does not improve parasite control.

Because parasite eggs are deposited in the manure, and larvae only travel a short distance up grass blades, animals grazing taller forages (well above ground level) will not consume worm eggs or larvae. Therefore, goats that are given ample browse will be much less likely to become infested with parasites. If goats are forced to graze at ground level, however, the goats may acquire a serious parasite load.

### *Potential Problems*

Problems may arise in the practice of mixed-species grazing. One of these is the potential for “bully” animals. In my experience on our own farm, the problem with mixing cattle and sheep was not the cattle being abusive to the sheep, but the ram being aggressive to the cattle! We had a big Charolais cow that the ram disliked so much, we had to feed her separately in the wintertime. The ram would chase the cattle on pasture, and prevent them from coming to the water trough. At lambing time, some cattle may be difficult and bothersome to the sheep, or the shepherd!

Another problem is supplemental feeding, including the feeding of trace minerals. The mineral supplement that is adequate for sheep may not be so for cattle, and a mineral supplement that is best for cattle may be toxic to sheep, as sheep do not tolerate much copper. This difficulty, and the one of aggressive animals, may be overcome by simply rotating the animals. If the sheep are grazed for a few days, then moved to a fresh pasture and the next species put on the first pasture, you may get the benefits to your pasture and avoid these problems.

Fencing is another issue to consider. Electric fencing is generally considered to be the most economical and convenient. Opinions vary as to number of strands needed: on our farm, we use 5 strands for the perimeter, and 2 or 3 strands for the division fences. We also have a powerful charger; but if sheep get in the habit of going through the fence, it's very hard to cure them. Goats are notoriously hard to contain in an area. The article, "How to Hotwire a Goat" gives one example of a fence that may control goats (11).

Another idea, if cattle fence is already in place, is to string off-set wires inside the fence. This should be set in about 8", and be 12-14" above ground, and must be maintained at 4,500 volts or better to be effective (12). Also, it is a good idea to train sheep or goats to electric fence. This is done by confining them in a small area with a very powerful fence, and encouraging the animals to "test" the fence by attaching shiny objects to the fence, or by placing feed on the other side of the fence, just out of reach. For best results, the training area should be surrounded by secure fencing, such as panels or woven wire or a board fence. This practice will discourage those individuals inclined to lunge forward or run through the fence after being shocked. Please refer to the ATTRA publication, *Introduction to Fencing and Paddock Design*, for more information regarding fencing.

Predators are a major problem for sheep and goats. Electric fencing helps to discourage predators, but it may also be necessary to employ a guardian animal. Some producers prefer livestock guardian dogs, such as the Great Pyrenees or the Anatolian dogs, while others are strong proponents of llamas or donkeys. Each has its advantages and disadvantages. More information on predator control is available from ATTRA.

### *Obstacles to Adoption*

A review of the literature on multispecies grazing included the proceedings from the Multispecies Grazing Conference, held at Winrock International in 1985 (22). Dr. Evert K. Byington submitted an article (13) which explored the question of what areas of the eastern United States could most benefit from the practice of multispecies grazing. Criteria included the number of cattle, types of pastures, availability of farmer-owned forested land for grazing, and other factors (see map). Certainly, multispecies grazing seems to be an excellent practice, with potential to improve pastures and land, and increase profits. So why is it still not a common practice, even 16 years after the conference?

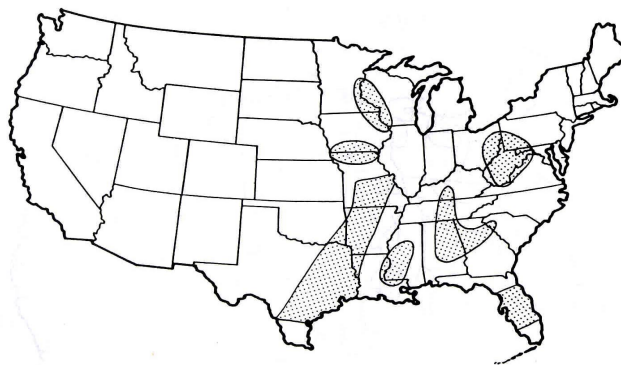

**Locations in the eastern U.S. where multispecies grazing management should be given priority as an alternative to existing forage/livestock systems (13).**

Knowledge may be the main factor. The decline in sheep production means that many farmers have no experience with sheep, and so may not be confident of their ability to manage that species. Learning to raise a new species takes time and energy, and inevitably involves “trial and error,” which can be terribly discouraging to a beginner. Prejudice against sheep and goats may prevent a cattleman from diversifying. Time and energy are factors, as well, since sheep and goats may increase the labor demand. Practical concerns such as those already listed – predators, parasites, supplemental feeding, fences, and facilities – may inhibit farmers. Some producers may decide that they’d prefer using a bulldozer or Roundup™ to control their weedy and brushy pastures rather than “mess with sheep or goats”. Lack of markets, or lack of knowledge of markets, may be an issue in some areas, as well.

On our small farm, we kept sheep and cattle together for a while. We eventually sold the cattle, for several reasons. First of all, we found it inconvenient to hire a trucker whenever we needed to sell a calf or take an animal to the veterinarian. We could not justify installing handling facilities for the small number of cows we needed to work, so anytime they needed to be vaccinated or dehorned, we had to arrange for hauling to the veterinarian. With no facilities, A.I. would be rather difficult, but keeping a bull for three cows was impractical. We could have chosen to buy calves rather than keep breeding stock, and that would simplify the management of the cattle since we would not have to worry about arranging for breeding, and would only need to hire hauling when we were ready to sell the calves. Our experience illustrates some potential difficulties for small producers.

### *Outlook*

What results can be expected from multispecies grazing? Research techniques vary, and differences in initial pasture composition, climate, experimental procedure, and particularly stocking rate, influence results. These and other variables may account for the varying and contradictory results reported in the literature. For example, lamb gains are improved under multispecies grazing systems, while calf gains are not affected (5) or are reduced (14) or are improved (4). A producer must be observant, and manage the pastures and animals well to maximize production and prevent damage through overgrazing. Also, it is important to think “long-term” – and give pastures time to improve and enhance animal performance. When adding a new animal species to your operation, start with small numbers and build slowly after gaining experience and adapting species to one another. This will greatly reduce risk during the learning process.

In conclusion, while multispecies grazing requires more thought and management, and more investment in facilities, it can have big payoffs for your pasture and your wallet. If you do decide to add one or more species to your operation, be sure to investigate your market options and your fencing options, and then start slowly. Select healthy stock, and be observant. Please contact ATTRA if you need more specific information.

## References:

- 1) Taylor, Charles A. 1985. Multispecies Grazing Research Overview (Texas). In: Proceedings of a conference on multispecies grazing. June 25-28, 1985, Winrock International, Morrilton, AR. p. 65-83.
- 2) Luginbuhl, J.M., et al. 2000. Use of goats to manage vegetation in cattle pastures in the Appalachian region of North Carolina. *Sheep and Goat Research Journal*, Vol. 16, No. 3. p. 124-130.
- 3) Forbes, T.D.A., and J. Hodgson. 1985. The reaction of grazing sheep and cattle to the presence of dung from the same or the other species. *Grass and Forage Science*. June. p. 177-182.
- 4) Meyer, Howard H., and T. G. Harvey. 1985. Multispecies Livestock Systems in New Zealand. In: Proceedings of a conference on multispecies grazing. June 25-28, 1985. Winrock International, Morrilton, AR. p. 84-92.
- 5) Abaye, A. O., et al. 1994. Influence of grazing cattle and sheep together and separately on animal performance and forage quality. *Journal of Animal Science*. April. p. 1013-1022.
- 6) Esmail, S.H.M. 1991. Multispecies grazing by cattle and sheep. *Rangelands*. February. p. 35-37.
- 7) Umberger, S. H., et al. 1985. Adding sheep to cattle for increased profits. In: Proceedings of a conference on multispecies grazing. Winrock International, Morrilton, AR. p. 212-214.
- 8) Rutherford, Burt. 1994. Sheep-Cattle bonding experiments prove successful in New Mexico research. *Ranch Magazine*. May. p. 26-27.
- 9) Taylor, C.A., and M.H. Ralphs. 1992. Reducing livestock losses from poisonous plants through grazing management. *Journal of Range Management*. January. p. 9-12.
- 10) Etchepare, John. 1985. Cattle and sheep in the Intermountain region. In: Proceedings of a conference on multispecies grazing. Winrock International, Morrilton, AR. June 25-28. p. 178-187.
- 11) Zweede-Tucker, Yvonne. 1997. How to hotwire a goat. *Cashmirror*. December. p. 19-21.
- 12) Hart, Steve. 2000. Sustainable brush control. In: Proceedings of the 15<sup>th</sup> Annual Goat Field Day. Langston University, Langston, OK. p. 32-35.



## References: continued

- 13) Byington, Evert K. 1985. Opportunities to increase multispecies grazing in the eastern United States. In: Proceedings of a conference on multispecies grazing. June 25–28. Winrock International, Morrilton, AR. p. 7–25.
- 14) Wedin, W. F. 1985. Multispecies grazing – Current use and activities (Midwest). In: Proceedings of a conference on multispecies grazing. June 25–28. Winrock International, Morrilton, AR. p. 45–48.
- 15) Ekarius, Carol. 1999. *Small-scale Livestock Farming*. Storey Books. Pownal, VT. p. 20, 39, 40. *This book is useful reading for anyone who wants to learn more about managing pastures and animals. Includes planning and marketing information, as well as an explanation of holistic management. Many farmer profiles and lots of examples to illustrate concepts.*
- 16) Anon. 1999. Sheep and multi-species grazing. Accessed 27 Feb. 2001. <<http://www.sheepusa.org/envspeci.htm>>.
- 17) Carter, Heidi. 1995. Multispecies grazing: An option to consider. *The Stockman Grass Farmer*. February. p. 35–36.
- 18) Fernandez, J. Marcos. 1999. Mixed-species grazing: Benefits range from better forage use to parasite control. *Goat Rancher*. April. p. 20–23.
- 19) McGuire, Kris. 1995. Grazing goats for the cattleman. *The Fiberfest Magazine*. Fall. p. 50–52.
- 20) Rutherford, Rob. 1997. Multispecies grazing: Questions and answers. *Holistic Management Quarterly*. April. p. 15, 16.
- 21) Schuster, J. L. 1985. Environmental and ecological implications of multispecies grazing. In: Proceedings of a conference on multispecies grazing. June 25–28, 1985. Winrock International, Morrilton, AR. p. 232–233.
- 22) Baker, Frank H., and R. Katherine Jones, ed. 1985. *Proceedings of a Conference on Multispecies Grazing*. June 25–28, 1985. Winrock International, Morrilton, AR. 235 p.

## Resources:

Kerr Center  
P.O. Box 588  
Poteau, OK 74953  
(918) 647-9123

The ATTRA Project is operated by the National Center for Appropriate Technology under a grant from the Rural Business-Cooperative Service, U.S. Department of Agriculture. These organizations do not recommend or endorse products, companies, or individuals.

**Abstract:** Rotational grazing is periodically moving livestock to fresh paddocks, to allow pastures to regrow. Rotational grazing requires skillful decisions and close monitoring of their consequences. Modern electric fencing and innovative water-delivery devices are important tools. Feed costs decline and animal health improves when animals harvest their own feed in a well-managed rotational grazing system. Included are lists of resources for further research and other ATTRA publications related to rotational grazing.

By Alice E. Beetz  
 NCAT Agriculture Specialist  
 November 2004  
 ©NCAT 2004

## INTRODUCTION

Ruminants such as cattle, sheep, and goats can convert plant fiber—indigestible to humans—into meat, milk, wool, and other valuable products. Pasture-based livestock systems appeal to farmers seeking lower feed and labor costs and to consumers who want alternatives to grain-fed meat and dairy products. The choice of a grazing system is key to an economically viable pasture-based operation.

Adding livestock broadens a farm's economic base, providing additional marketable products and offering alternative ways to market grains and forage produced on the farm. In addition,



©2002 www.arktoday.com

### Table of Contents

Introduction.....	1
Choosing a Grazing System.....	2
Making the Change.....	3
Fencing and Water Systems.....	4
Forage Growth.....	4
Managing Forage Growth.....	5
Seasonal Adjustments.....	6
Effects on the Animals.....	6
Information Resources.....	7
Conclusion.....	7
References.....	9
Enclosures.....	9
Grazing Books.....	9
Periodicals with a Grazing Focus.....	11
Web Resources.....	11

soil losses associated with highly erodible land used for row crops decline when such land is converted to pasture. Besides these benefits, rotating row crops into a year or two of pasture increases organic matter, improves soil structure, and interrupts the life cycles of plant and livestock pests. Livestock wastes also replace some purchased fertilizers.

Because ruminants co-evolved with grassland ecosystems, they can meet their nutritional needs on pasture. A profitable livestock operation can be built around animals harvesting their own feed. Such a system avoids harvesting feed mechanically, storing it, and transporting it to the animals. Instead, the livestock are moved to

the forage during its peak production periods. Producers manage the pasture as an important crop in itself, and the animals provide a way to market it.

Reduced feed and equipment costs and improved animal health result from choosing species well-suited to existing pasture and environmental conditions. In most operations, a good fit between animals and available pasture provides more net income. ATTRA's publication *Matching Livestock and Forage Resources in Controlled Grazing* goes into more depth on this subject.

Some animals will produce acceptable meat with little or no grain finishing. Marketing these lean meats directly to consumers is an opportunity to increase profits. Skilled managers who can consistently offer high-quality forage to their animals, producing lean and tender meat, should consider pursuing this market.

## CHOOSING A GRAZING SYSTEM

Continuous grazing, the most common grazing system in the United States, usually results over time in a plant community of less-desirable species. When livestock graze without restriction, they eat the most palatable forage first. If these plants are repeatedly grazed without allowing time for their roots to recover and leaves to regrow, they will die. Plants not eaten by livestock mature and go to seed. Thus, populations of undesirable plants increase, while preferred plants are eliminated, reducing the quality of the forage in a given pasture. Trampling and animals' avoidance of their own wastes further reduce the amount of usable forage.

Continuous grazing does, however, have the benefit of low capital investment, since few fencing and watering facilities are required. Because livestock are seldom moved from pasture to pasture, management decisions are simple. This type of grazing frequently results in higher *per-animal* gains than other grazing systems, as long as adequate forage is available to



## Related ATTRA Publications

- *Sustainable Pasture Management*
- *A Brief Overview of Nutrient Cycling in Pastures*
- *Nutrient Cycling in Pastures*
- *Assessing the Pasture Soil Resource*
- *Converting Cropland to Perennial Grassland*
- *Matching Livestock and Forage Resources in Controlled Grazing*
- *Multispecies Grazing*
- *Meeting the Nutritional Needs of Ruminants on Pasture*
- *Grazing Networks for Livestock Producers*
- *Introduction to Paddock Design & Fencing-Water Systems for Controlled Grazing*
- *Protecting Riparian Areas: Farmland Management Strategies*
- *Managed Grazing in Riparian Areas*
- *Dung Beetle Benefits in the Pasture Ecosystem*

maintain high growth rates. But if pastures are overstocked, growth rates dwindle.

Rotational (or controlled) grazing, on the other hand, increases *pounds of animal production per acre*. How the system is managed influences the level of production, of course. In fact, management-intensive grazing (MIG) is another term for rotational grazing. This term emphasizes the intensity of the management rather than the intensity of the grazing.

Management-intensive grazing (MIG) is grazing and then resting several pastures in sequence. The rest periods allow plants to recover before they are grazed again. Doubling the forage use on a given acreage is often possible with the change from continuous to controlled grazing. There is considerable profit potential for the producer willing to commit to an initial capital investment and increased management time.(1) The producer can meet individual animal gain or gain-per-acre goals with sound management decisions.

### An easy way to begin MIG

An easy way to begin MIG is to subdivide existing pastures with one or two fences (or simply close existing gates). Managing these simple divisions is a chance to try out a more controlled system and begin learning this type of grazing management at a basic level.

If the new fences are electrified high-tensile wire, animals will learn to respect them, and managers can practice handling them. The manager's observation skills develop as the animals and forages adjust to the change.

Faced with low milk prices, the potential loss of price supports, and ever-rising costs, some dairy producers have changed to MIG to meet economic and quality-of-life goals. Some are providing cows fresh paddocks after each milking. Seasonal dairying—drying off the entire herd during times when pasture production is low—is often the next step, but it requires even more skillful management and may not be as profitable. For more information, see the ATTRA publications *Grass-Based and Seasonal Dairying* and *Economics of Grass-Based Dairying*.

MIG can be used in many other operations as well. Cow-calf and stocker operations benefit from increased forage and higher-quality feed under MIG. Some graziers specialize in dairy beef or in raising replacement heifers for dairy operations. When MIG is used with sheep and goats, fencing must be excellent in order to keep the livestock in and the predators out. (Guard animals can enhance predator protection. More in-depth information about guard animals is available from ATTRA.)

MIG offers the manager a wide range of options in terms of grazing intensity. The enclosed chapter from *Forages, the Science of Grassland Agriculture* provides a thorough discussion of various grazing systems. The section "Building Forage-Livestock Systems" deserves special attention.

An Iowa farmer once said he hoped that scientists would soon discover that "animals like to move around and grass likes to stand still."

### MAKING THE CHANGE

When making a change in grazing management, a logical first step is an inventory of the farm's resources. An outline to help in this inventory process is enclosed. Another useful tool is an aerial map of the farm on which to mark fences, water supplies, and existing forage resources. Writing down farm and family goals in this process makes it easier to stay on course with management decisions. When a salesperson is applying pressure, for instance, it helps to be able to evaluate the cost of the product against some chosen goal.

Implementing rotational grazing requires subdividing the land into paddocks, providing access to water, adjusting stocking rates, and monitoring grazing duration. These decisions may seem overwhelming at first. Some of the enclosed materials offer information about setting up paddocks to fit the landscape, calculating stocking rates, and estimating forage yield and availability. For more information, see ATTRA's *Introduction to Paddock Design*.

The change to controlled grazing will have impacts on the animals, the plant community, and the farmers. Livestock operators who have not monitored their livestock daily or weekly will feel the greater time demands. On the other hand, the need for harvested forages declines, resulting in less time spent making hay or silage. Purchased feed costs also shrink.

Economic benefits come from improved animal health and increased production. Research confirms lower feed costs and fewer vet bills on most operations making this transition.

Actual figures vary widely, depending on the profitability and forage condition under the old system. As the new system is fine-tuned, feed quality improves, quantity increases, and management skills also grow. As a result, more

animals can be raised on the same acreage, translating into more income for the farm.

It takes commitment to succeed in making the change to MIG, a system requiring more complex management skills. Old ways of thinking will need to shift, as analytical and problem-solving skills develop. The new grazier's commitment will be tested by mistakes, unexpected weather patterns, and neighbors' attitudes.

## FENCING AND WATER SYSTEMS

Rotational grazing requires additional fencing. High-tensile electric fencing is cheaper and easier to install than conventional fencing. Temporary as well as permanent electric fencing is available, and many producers use a combination of the two. This equipment offers flexibility in managing animal and plant resources.

Animals need to be trained to electric fences. Producers sometimes use a special paddock for introducing new stock into the system (fencing suppliers can furnish information). Once animals learn to respect the electrified wire, it becomes a psychological rather than a physical barrier.



Providing water is another capital requirement of rotational grazing systems. Experienced producers soon see the value of adequate water, and some regret that they did not invest more in the water system initially. Designing a water system for *future* expansion may be the best option for beginners with limited funds.

Many producers use pipes and portable waterers to create movable water systems and design permanent systems based on this experience. Flexibility in locating water within paddocks should be part of any final design, so the manager can control animal distribution and avoiding trampling around the water source.

Some paddocks have alleyways that give animals access to one water source from several side-by-side paddocks. However, the area around a permanent water source will suffer from heavy traffic. This heavy-use area tends to accumulate nutrients and is a potential source of parasites, disease, and erosion. (Many producers see the same problems in any location where animals congregate; e.g., shade trees and mineral sources.)

Heavy livestock traffic around ponds, springs, or streams can destroy vegetation. Piping water away from these sources or limiting animals' access results in higher-quality water for them, and it benefits wildlife habitat.

Some producers report economic benefits from providing cool, high-quality water, though little research exists. Mineral blocks are typically placed near the water supply, but excessive use of the area can lead to the problems mentioned above. Placing the minerals away from water or other gathering areas helps redistribute the animals' impact and avoids overuse of any one area. Dispensing soluble minerals in the water is another alternative. For more information on fencing and water, see ATTRA's *Introduction to Paddock Design*.

## FORAGE GROWTH

How much pasture area to offer animals and how long to keep them there are critical decisions for a successful grazier. These decisions influence the amount and quality of forage available throughout the grazing season.

**Figure 1. Forage Growth Curve.**

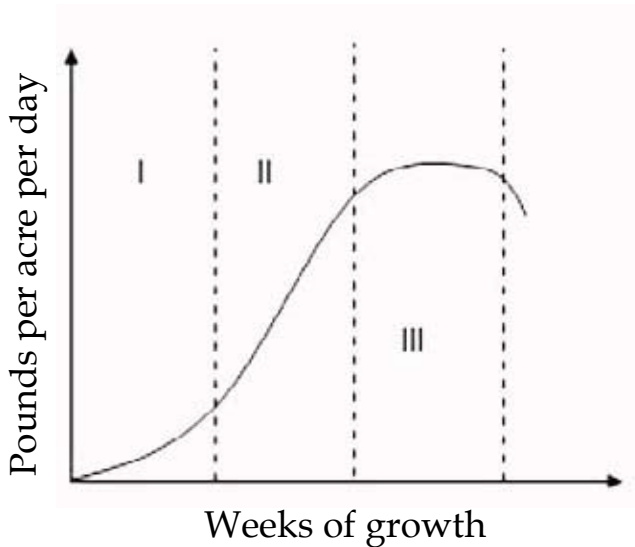

Figure 1 shows the natural progression of forage growth through three stages. Phase one is the first growth in the spring or the time required for regrowth after extreme defoliation. Photosynthesis is low because of the small leaf area available to capture solar energy.

During phase two, plants grow rapidly because leaf area is increasing. Toward the end of this growth phase, forage growth is near its peak, and it is of high quality. This lush and abundant forage is ideal for grazing.

The transition from phase two to phase three marks the beginning of reproduction and slower plant growth. Lower leaves begin to die as they are shaded out by those above. Plant resources are used for reproduction rather than more growth, and forage quality declines.

### **MANAGING FORAGE GROWTH**

The grazer manages this forage growth-curve to keep pastures producing a maximum amount of high-quality forage. Decisions about moving animals from paddock to paddock are based on the amount of forage available, size of paddocks, and estimated seasonal growth rates. The number and nutritional needs of the livestock must also

be figured into this balance. Additional information on these management decisions is included in the enclosures.

After each grazing period, if adequate leaf area is left for photosynthesis, plants quickly replace leaves lost without depleting root reserves. The animals are moved to fresh, succulent pasture before plants are overgrazed. Thus the plants and animals both benefit from good grazing management.

Many desirable plants, including legumes and native grasses, disappear from pastures that are not given adequate rest. Animals must be moved after three to five days, maximum, to prevent them from grazing these plants' regrowth.

If not removed from the area, livestock will preferentially graze certain forages and deplete root reserves, thus killing the most palatable forage species. Continuous grazing thus eliminates desirable species and maintains those that can tolerate repeated defoliation, such as tall fescue.

Management-intensive grazing encourages a wide variety of plants in the pasture. Plant diversity increases in adequately rested pastures. Plants adapted to the varied soil and moisture conditions of the landscape thrive in their microclimates. Animals can graze plants during their seasons of maximum palatability.

Livestock will, in fact, eat many weeds in their vegetative stage, some of which are good feed. By eating weeds such as dandelions, quackgrass, redroot pigweed, and lambsquarters when they are young and tender, grazing animals keep both annuals and perennials from going to seed. These plants have been shown to have feed values that compare favorably with oats.(2)

---

#### **Profits improve because:**

- 1. The stocking rate is higher.**
- 2. The grazing season is longer.**
- 3. There is less need for land dedicated to "hay production only."**
- 4. There is less dependence on mechanical equipment.**
- 5. Animal health improves.**

Keith Johnson, Forage Crops Specialist,  
Purdue University Cooperative Extension Service

---

Dairy or fast-growing meat animals will need energy or fiber supplementation at certain times of the season, depending on what they can graze for themselves. Since what livestock eat is different from a random profile of the plants in the pasture, forage samples or harvested forage tests will not exactly reflect true animal intake. It is, therefore, difficult for the manager to know whether protein or energy supplementation is economically justified.

Other than salt, the need for mineral supplements is likewise difficult to determine. If soil tests show micronutrients are missing, they can be added to the mineral mix. However, some may be present in the soil but unavailable to the plants. Adjusting pH often remedies this. While some consultants argue that missing micronutrients should be applied to the soil so they can be eaten as plant material, mineral supplements are often the most economical solution. Minerals not removed by grazing will cycle with other nutrients in the pasture as the years go by.

---

## SEASONAL ADJUSTMENTS

---

Rotational grazing gives the livestock manager flexibility in responding to the changing forage supply. During periods of rapid plant growth, cattle are moved quickly through paddocks. Alternatively, if equipment is available or the work can be hired, excess forage can be harvested for feeding later. During periods of slow plant growth, delayed rotation allows plants

in each paddock a longer time to recover after each grazing period.

Various strategies or specialized forages can delay having to feed harvested forages. In late fall, stockpiled fescue or other winter grasses can be strip grazed. Grain and stalks left in corn or milo fields after harvest, offered as strips, provide another source of good-quality feed into the winter months. Small grains, grown alone or with brassicas, are a third option in some parts of the country for extending the grazing season.

In some regions, providing excellent grazing through the hottest summer months is the biggest challenge. Native grasses, summer annuals, and interseeded legumes can offset this slump. However, the costs of establishment—in time and money—are justified only if the resulting increase in livestock production translates into sufficient profit. *Sustainable Pasture Management*, a companion ATTRA publication, provides further information on this subject.

---

## EFFECTS ON THE ANIMALS

---

Multiple paddocks make access and handling easier. Cattle become easier to work when they see people as the source of fresh pasture. Managers who observe their animals frequently can identify and treat health problems in their early stages.

If just beginning an animal operation, the producer should choose a breed adapted to the climate and grazing system or pick individual



©2002 www.arttoday.com

animals with good performance records on pasture. Some types of animals, even within a breed, can better use high-quality forage, and others are better adapted to low-quality rangelands. Some tolerate legumes without bloating.

There is as much variation among individuals within the breeds as between breeds. To some extent, animals learn grazing skills.(3) Therefore, animals that have been raised on pasture – especially those from a controlled grazing system – are desirable. In an established herd, culling animals that don't adapt is essential to achieving a profitable grass-based livestock system.

## INFORMATION RESOURCES

A host of published and electronic information about rotational grazing is available to producers.

Many land-grant universities have materials about rotational grazing that are specific to their states. Workshops and videos on management-intensive grazing may be available as well. Check with local Extension offices regarding such resources.

The Natural Resources Conservation Service (NRCS) has grazing specialists in each state to help farmers improve their grazing management. Your county NRCS office can refer you to the grazing specialist in your area.

*The Stockman Grass Farmer* (SGF) (4) is an excellent monthly publication for news about alternative forages and innovative management strategies, as well as for discussions among practitioners of management-intensive grazing. In



addition, the commercial and classified ads offer many services, including grazing workshops and supplies, that may be difficult to obtain locally. Suppliers and their salespeople often serve as consultants, having practical experience of many grazing operations. A free sample issue of SGF is available to those who call or write to request it.

A list of books on grazing is provided at the end of this publication. If local libraries and bookstores are unable to get them, any issue of *The Stockman Grass Farmer* has an ordering form for many of them.

Holistic Management™ is a decision-making process initially used for livestock management on range. Now the model is being used by many farmers and ranchers to evaluate options as they plan for changes to their operations. The Center for Holistic Management (5) can refer producers to state organizations and regional representatives, who can in turn provide information and contacts with practitioners. After initial training courses, Holistic Management practitioners often form management clubs to further their understanding and learning as they apply holistic management principles. See the ATTRA publication *Holistic Management*.

There are many agricultural discussion groups on the Internet covering a wide range of topics. Internet discussion groups operate via e-mail. Listservers receive and distribute postings. When you subscribe, your name gets added to the mailing list. If you wish to post to the discussion group, you only need to send one e-mail, and the listserver will send it to all members. Subscribing to newsgroups is a simple and painless process, and it is free. There are lists associated with most ruminant breeds (see Table 1). A search engine such as Yahoo! can help locate other lists on the Web.

## CONCLUSION

Management-intensive grazing is not for every producer. It will not instantly provide wealth and leisure or solve all the problems livestock producers face. Some experienced graziers say it takes three years of observation and manipulation of soil, plant, and animal resources to really



begin to manage them well. During these years there will be countless challenges and necessary adjustments. Every attempt to prepare for potential problems will make the transition smoother. An assumption that the system can continually be improved will help the manager to identify weak areas early. Being alert for difficulties ensures that they can be addressed before they become serious.

Nevertheless, those producers who have made the change to MIG report many benefits, including increased net income and improved quality of life. In groups of these innovative graziers, one is struck

## Table 1. Internet Listservers

Listservers are electronic discussion groups that often include experienced producers, researchers, and educators. They are a rich resource, but since they are rarely moderated, evaluate the information carefully.

### Grazing Lists

Graze-I discusses intensive rotational grazing and seasonal grazing. This newsgroup is based in New Zealand and has a definite international feel to it.

To subscribe send an e-mail to [listserv@taranaki.ac.nz](mailto:listserv@taranaki.ac.nz).

In the body of the e-mail type "subscribe graze-I."

Graze-I also has a Web page with an archive of past discussions:

<http://grazel.taranaki.ac.nz/>.

The Grazer's Edge is another on-line forum.

To subscribe to the grazersedge listserve, send e-mail to [grazersedge-subscribe@egroups.com](mailto:grazersedge-subscribe@egroups.com).

### Sheep

There is a list for sheep called **SHEEP-L**.

To subscribe to SHEEP-L, send the message "subscribe SHEEP-L Your Name" to [listserv@listserv.uu.se](mailto:listserv@listserv.uu.se). Post e-mail messages at [sheep1@listserv.uu.se](mailto:sheep1@listserv.uu.se).

### Goats

Subscription address: [Listproc@listproc.wsu.edu](mailto:Listproc@listproc.wsu.edu).

In subject line and message area type "subscribe goats-Your Name."

### Dairy

[Dairy-L@umdd](mailto:Dairy-L@umdd) discusses a wide range of dairy issues. Topics tend to revolve mainly around the feeding and health of dairy cows. Discussions are based around the American / Canadian confinement system.

To subscribe send an e-mail to [listserv@umdd.umd.edu](mailto:listserv@umdd.umd.edu).

In the body of the message type "SUB Dairy-L Your Name".

by the enthusiasm and creativity they bring to the management of their particular pasture systems. They observe the results of their decisions and are constantly fine-tuning their systems to meet their production and family goals.

## REFERENCES

- 1) Kole, Glenn. 1992. We compared herds in confinement and herds that graze. *Hoard's Dairyman*. Vol. 138, No. 2. p. 47.
- 2) Marten, Gordon C. 1978. The animal-plant complex in forage palatability phenomena. *Journal of Animal Science*. Vol. 46, No. 5. p. 1476.
- 3) Forbes, J.M. 1995. *Voluntary Food Intake and Diet Selection in Farm Animals*. CAB International, Wallingford, England. p. 353.
- 4) The Stockman Grass Farmer  
P.O. Box 9607  
Jackson, MS 39286-9607  
800-748-9808 (toll-free)  
<http://stockmangrassfarmer.com/sgf/>
- 5) Center for Holistic Management  
The Savory Center  
1010 Tijeras, NW  
Albuquerque, NM 87102  
505-842-5252  
800-654-3619 (toll-free)  
[www.holisticmanagement.org/](http://www.holisticmanagement.org/)

## ENCLOSURES

- Adams, Don et al. 1996. Matching the cow with forage resources. *Rangelands*. April. p. 57-62.
- Daigle, Paul. 2001. Top 10 mistakes of new graziers. *The Stockman Grassfarmer*. May. p. 36-37.

Gerrish, Jim. 1993. *Management Intensive Grazing: Principles and Techniques*. Handout at Stockman Grass Farmer North American Grazing Conference, Jackson, MS. December 1-3. 21 p.

Matches, Arthur G., and Joseph C. Burns. 1995. Systems of grazing management. p. 179-92. *In: Barnes, Robert F., Darrell A. Miller, and C. Jerry Nelson (eds.). Forages: The Science of Grassland Agriculture*. 5th ed. Vol. 2. Iowa State University Press, Ames, IA.

Mundy, Victoria. 1995. Successful grazing systems start with solid goals. *NSAS Newsletter*. No. 52. p. 4-5.

Stockman Grassfarmer Bookshelf. 4 p.

## GRAZING BOOKS

Ball, Donald M., Carl S. Hoveland, and Garry D. Lacefield. 1996. *Southern Forages*, 2<sup>nd</sup> Ed. Potash & Phosphate Institute and the Foundation for Agronomic Research, Norcross, GA. 264 p.

*Available for \$25 + \$4 s&h from:*  
Potash & Phosphate Institute  
Norcross, GA 30092  
770-447-0335

Barnes, Robert F., Darrell A. Miller, and C. Jerry Nelson (eds.). *Forages: An Introduction to Grassland Agriculture*. 5th ed. Vol. 1. Iowa State University Press, Ames, IA. 516 p.

Barnes, Robert F., Darrell A. Miller, and C. Jerry Nelson (eds.). *Forages: The Science of Grassland Agriculture*. 5th ed. Vol. 2. Iowa State University Press, Ames, IA. 357 p.

Grandin, Temple. 1993. *Livestock Handling and Transport*. CAB International, Wallingford, U.K. 320 p.

Heitschmidt, Rodney K., and Jerry W. Stuth. 1991. *Grazing Management: An Ecological Perspective*. Timber Press, Portland, OR. 259 p.

Hodgson, John. 1990. *Grazing Management: Science into Practice*. Longman Handbooks in Agriculture. John Wiley & Sons, NY. 203 p.

Hodgson, J., and A.W. Illius (eds.). 1996. *The Ecology and Management of Grazing Systems*. CAB International. Wallingford, U.K. 466 p.

Murphy, Bill. 1998. *Greener Pastures on Your Side of the Fence: Better Farming With Voisin Grazing Management (4<sup>th</sup> ed.)*. Arriba Publishing, Colchester, VT. 379 p.

*Available for \$30 from:*  
Arriba Publishing  
213 Middle Rd.  
Colchester, VT 05446

Nicol, A.M. (ed.). 1987. *Livestock Feeding on Pasture*. Occasional Publication No. 10. New Zealand Society of Animal Production. Private Bag, Hamilton, New Zealand. 145 p.

*Available for \$20 ppd. from:*  
New Zealand Society of Animal Production  
AgResearch, Ruakura  
PB3123  
Hamilton, NZ  
NZSAP.ANIMAL@xtra.co.nz  
<http://nzsap.rsnz.govt.nz>

Savory, Allan, with Jody Butterfield. 1999. *Holistic Management: A New Framework for Decision Making*. Island Press, Covelo, CA. 616 p.

Smith, Burt, Ping Sun Leung, and George Love. 1986. *Intensive Grazing Management: Forage, Animals, Men, Profits*. The Graziers Hui, Kamuela, HI. 350 p.

*Available for \$29.95 from:*  
The Graziers Hui  
P.O. Box 1944  
Kamuela, HI 96743  
808-885-7553

Turner, Newman. 1974. *Fertility Pastures and Cover Crops*. Bargyla and Gylver Rateaver, Pauma Valley, CA. 202 p.

*Available for \$25 from:*

Bargyla Rateaver  
9049 Covina St.  
San Diego, CA 92126  
619-566-8994

*(Also available are Turner's Fertility Farming and Herdsmanship for \$35 each.)*

Wilkinson, J.M. 1984. *Milk and Meat from Grass*. Granada, New York, NY. 149 p.

*A few copies still available for \$26.50 + \$4 s&h from:*

Sheridan House Inc.  
Dobbs Ferry, NY 10522  
914-693-2410

The following grazing books are available from the Stockman Grass Farmer's Bookshelf. A copy of the order form and brief descriptions of the books are included in the enclosures, or you can visit the electronic version at <http://stockmangrassfarmer.com/sgf/bookshelf.html>.

Ekarius, Carol. 1999. *Small-scale Livestock Farming: A Grass-based Approach for Health, Sustainability and Profit*. Storey Books, Pownal, VT. 218 p.

Gerrish, Jim. 2004. *Management-intensive Grazing*. Green Park Press, Ridgeland, MS. 320 p.

Hazard, Gordon. 2002. *Thoughts and Advice from an Old Cattleman*. Hazard Cattle Co., West Point, MS. 146 p.

Judy, Greg. 2002. *No Risk Ranching*. Green Park Press, Ridgeland, MS. 240 p.

Nation, Allan. 2000. *Knowledge Rich Ranching*. Green Park Press, Ridgeland, MS. 336 p.

Nation, Allan. 1992. *Pa\$ture Profit\$ with Stocker Cattle*. Green Park Press, Jackson, MS. 224 p.

Nation, Allan. 1997. Paddock Shift: Changing Views on Grassland Farming. Green Park Press, Jackson, MS. 192 p.

Salatin, Joel. 1995. Salad Bar Beef. Polyface, Swoope, VA. 365 p.

Schroedter, Peter. 1997. More Sheep, More Grass, More Money. Ramshead Publishing, Moosehorn, Man. 112 p.

Smith, Burt. 1998. Moving 'Em: A Guide to Low Stress Animal Handling. The Graziers Hui, Kamuela, HI. 352 p.

Walters, Charles, and Gearld Fry. 2003. Reproduction & Animal Health. Acres, USA, Austin, TX. 222 p.

---

### PERIODICALS WITH A GRAZING FOCUS

---

The Forage Leader  
American Forage and Grassland Council  
P.O. Box 94  
Georgetown, TX 78627  
800-944-2342  
[www.afgc.org](http://www.afgc.org)  
*A membership benefit; membership cost \$30/yr.*

Graze  
P.O. Box 48  
Belleville, WI 53508  
[www.grazeonline.com](http://www.grazeonline.com)  
*\$30 for 1 year subscription*

Hay & Forage Grower  
2104 Harvell Circle  
Bellevue, NE 68005  
866-505-7173 (toll-free)  
<http://hy.pbsub.com/>  
*\$12/yr.*

The Stockman Grass Farmer  
P.O. Box 9607  
Jackson, MS 39286-9607  
800-748-9808 (toll-free)  
<http://stockmangrassfarmer.com/sgf/>  
*\$32/yr.*

Holistic Management In Practice  
The Savory Center  
1010 Tijeras NW  
Albuquerque, NM 87102  
505-842-5252  
[www.holisticmanagement.org](http://www.holisticmanagement.org)  
*\$30/yr.*

---

### WEB RESOURCES

---

Many resources are now available on the Internet. Besides listservers, mentioned in the box above, there are many useful Web sites. Several are listed below. Also, be sure to check the Web sites of nearby land-grant universities. They often contain information useful to both the beginner and the experienced grazer. Note that these addresses change often.

#### The Great Lakes Grazing Network

[www.glgm.org/](http://www.glgm.org/)  
*Best all-around site for grazing information; provides access to grazing and forage information for the states surrounding the Great Lakes; quality links.*

#### Cornell Forage-Livestock System

[www.css.cornell.edu/forage/forage.html](http://www.css.cornell.edu/forage/forage.html)  
*Excellent forage information for northeast states, including a forage selection tool for NY; grazing manual.*

#### Rangelands West

<http://rangelandswest.org/>  
*Provides access to many sources of information on rangeland management, including the Extension sites of the western land-grant universities.*

#### American Farmland Trust's Grassfarmer Site

<http://grassfarmer.com/>  
*Information doorway for grass-based farming, with special emphasis on dairy.*

#### University of Wisconsin Forage and Extension Links

[www.uwex.edu/ces/forage/links.htm](http://www.uwex.edu/ces/forage/links.htm)  
*Extensive research-based information on grazing, including access to other states' variety trial results; extensive dairy information is included.*

### **Forage Systems Research Center**

<http://aes.missouri.edu/fsrc/>

*Grazing schools and workshops; publications and research.*

### **Sustainable Farming Connection's Grazing Page**

[www.ibiblio.org/farming-connection/grazing/home.htm](http://www.ibiblio.org/farming-connection/grazing/home.htm)

*Grazing discussion group; practical information on fencing and grazing management; forage resources.*

### **North Dakota State University Grassland Report Index**

[www.ag.ndsu.nodak.edu/dickinso/grassland/rangrpt.htm](http://www.ag.ndsu.nodak.edu/dickinso/grassland/rangrpt.htm)

*Extensive collection of articles on grazing management in the rangeland environment; soil concerns and forages; livestock nutrition.*

### **University of Minnesota**

[Copies of the following two publications can be bought by calling 800-876-8636.]

#### **Grazing Systems Planning Guide**

[www.extension.umn.edu/distribution/livestocksystems/DI7606.html](http://www.extension.umn.edu/distribution/livestocksystems/DI7606.html)

*A step-by-step guide to planning a grazing system, including inventory of resources, goal-setting, designing fencing and water systems, forage requirements, and grazing system monitoring.*

#### **Knee Deep in Grass – A Survey of Twenty-nine Grazing Operations in Minnesota**

[www.extension.umn.edu/distribution/livestocksystems/DI6693.html](http://www.extension.umn.edu/distribution/livestocksystems/DI6693.html)

*A survey of grazing dairies that includes information that would be useful to other grazing operations.*

#### **State Grazing Lands Conservation Initiative Coordinators and Grazing Lands Personnel**

[www.glci.org/StateGLCI.htm](http://www.glci.org/StateGLCI.htm)

*Map and list of designated GLCI grazing specialists for each state.*

### **Ohio State Extension**

[Copies of this publication can be ordered by calling (614) 292-1607.]

#### **Maximizing Fall and Winter Grazing of Beef Cows and Stocker Cattle**

<http://ohioline.osu.edu/b872/index.html>

*Besides excellent material on season extension grazing strategies, various harvest methods and supplementation plans are described.*

### **Rotational Grazing**

**By Alice E. Beetz**

**NCAT Agriculture Specialist**

**November 2004**

**©2004 NCAT**

**IP086**

**Slot# 47**

**Edited by Paul Williams**

**Formatted by Cynthia Arnold**

**Version 030405**

The Electronic version of *Rotational Grazing* is located at:

HTML:

<http://www.attra.ncat.org/attra-pub/rotategr.html>

PDF

<http://www.attra.ncat.org/attra-pub/PDF/rotgraze.pdf>

# Grazing Systems Planning Guide

**Kevin Blanchet**

University of Minnesota Extension Service

**Howard Moechnig**

Natural Resources Conservation Service  
Minnesota Board of Water & Soil Resources

**Jodi DeJong-Hughes**

University of Minnesota Extension Service





# Grazing Systems Planning Guide

**Kevin Blanchet**

University of Minnesota Extension Service

**Howard Moechnig**

Natural Resources Conservation Service  
Minnesota Board of Water & Soil Resources

**Jodi DeJong-Hughes**

University of Minnesota Extension Service

The information in this publication is for educational purposes only and any reference to commercial products or trade names intends no discrimination and implies no endorsement by the University of Minnesota Extension Service.

For Americans with Disabilities Act accommodations, please call (800) 876-8636.

The University of Minnesota Extension Service is an equal opportunity educator and employer.

# TABLE OF CONTENTS

<b>1. INTRODUCTION .....</b>	<b>4</b>
<i>Grazing Management Systems</i>	
<b>2. GRAZING RESOURCE INVENTORY .....</b>	<b>6</b>
<i>Goals</i>	
What are my goals for the grazing system?	
<i>Land and Soils</i>	
What land resources are available for the grazing operation?	
What is the productivity of the soils?	
Are there sensitive land areas or soil limitations for grazing in the pasture?	
<i>Livestock</i>	
What are the forage requirements for each livestock herd?	
What are the plans for potential expansion of the livestock operation?	
How many herds will be grazed?	
<i>Forages</i>	
What are the existing forage species in the pasture?	
How healthy or in what condition is the pasture?	
What are the estimated yields and seasonal distribution of the existing forages?	
<i>Water Sources</i>	
What are the existing water sources and where are the drinking facilities?	
What are the other potential water sources?	
<i>Fence</i>	
What are the types and condition of the existing fences?	
<b>3. GRAZING PLAN DEVELOPMENT .....</b>	<b>13</b>
<i>Paddock Design and Layout</i>	
How many paddocks are needed for a rotational grazing system?	
How do I decide paddock size?	
What are some considerations for paddock layout?	
<i>Fence Design and Layout</i>	
What kind of fence should I install?	
<i>Water System Design and Layout</i>	
How can I supply adequate water to the livestock?	
Where should drinking facilities be located?	
<i>Heavy Use Area Planning</i>	
What do I consider when planning livestock lanes?	
How do I stabilize the livestock lanes?	
How do I keep the area around water facilities from becoming mudholes?	
<b>4. PASTURE MANAGEMENT .....</b>	<b>19</b>
<i>Pasture Forage and Livestock Management</i>	
What is proper grazing management for the desired forage species?	
How do pasture and livestock management affect plant growth and forage quality?	
When do I start grazing in the spring?	
When do I move livestock from paddock to paddock?	
<i>Pasture Soil Fertility Management</i>	
Can nutrients from livestock manure be utilized more efficiently in pastures?	
When is increasing soil pH with lime important for forage production?	
How much nitrogen fertilizer do I need to put on my pasture?	
Does phosphorus and potassium fertilizer improve pasture productivity?	



*Pasture Brush and Weed Control*

- Can unwanted weeds be controlled through grazing?
- What are the cultural and mechanical brush and weed control alternatives for pastures?
- When is control of brush and problem weeds with herbicides the best option?

*Sacrificial Paddock Management*

- How will the livestock be managed during times of drought or wet conditions?
- Will sacrificial paddocks be rejuvenated after removal of livestock?

**5. GRAZING SYSTEM MONITORING ..... 27**

*Pasture Record Keeping*

- How do I know I have enough forage available?
- Is the productivity of the pasture increasing?
- Are the natural resources improving?

**6. GRAZING PLAN EXAMPLE ..... 29**

**7. REFERENCES ..... 33**

**8. APPENDICES ..... 34**

- A Livestock Forage Monthly Balance Sheet
- B1 Identification Key for Common Forage Species – Grass
- B2 Identification Key for Common Forage Species – Legume
- C1 Determining Grassland Condition/Trend
- C2 Inventory Category Items
- D1 Average Forage Yields for Northern Minnesota and Northern Wisconsin
- D2 Average Forage Yields for Southern Minnesota and Southern Wisconsin
- E Water System Design Considerations
- F Visual Method for Calculating Reserve Herd Days
- G Calculated Method for Reserve Herd Days
- H Grazing Plan Checklist



# Introduction

This guide discusses the components of a grazing system by taking you through the grazing management planning process. Information on grazing resource inventory, plan development, pasture management, and system monitoring is provided. Each section has a series of questions that will lead you through the decision-making process of developing your plan. Your grazing plan will become customized to fit your operation depending upon how you answer the questions and integrate the components. Pasture-based livestock systems can be profitable enterprises if the available resources are managed effectively.

With approximately 16 percent of Minnesota's land in forage production, our pasture land is an important economic resource. Grazing management, such as rotational grazing that extends the amount of time that livestock can meet their needs through grazing and reduces the need for harvested feedstuffs, will lower feed costs and add to profitability.

Reducing costs and/or increasing production are the two avenues that livestock producers have for improving profitability. Focusing on management and control of production and pasture resources can be a cost reducing strategy. A well-managed rotational grazing system can reduce or eliminate the need for labor-intensive or purchased inputs such as supplemental feed, nitrogen fertilizer, and weed and brush killers. Improved pasture condition and higher forage yields can also lead to more animal production per pasture acre. Since feed costs are the major cost in almost all livestock operations, getting control of them is critical.

Designing a grazing plan is the first step in your pasture management system. As you follow the planning process, the strengths and weaknesses of your current system will become apparent. The grazing plan should include all the components of the grazing and pasture system and serve as a map for making management improvements.

Components of a typical grazing plan:

- Goals of the farming operation
- Summary of sensitive areas
- Livestock summary and forage requirements
- Fencing system
- Livestock watering system
- Heavy use area protection
- Forages
- Grazing system management

*For a complete grazing plan checklist see appendix H.*

Grazing systems range from continuous grazing of one area over a long period of time to intense rotational grazing on small areas for short periods of time. Livestock systems that use continuous grazing of a pasture experience both overgrazing and undergrazing of forages. A rotational system provides a rest opportunity for forage plants so that they may regrow more quickly. The rotational system provides an opportunity to move livestock based on forage growth, promote better pasture forage utilization, and extend the grazing season. The advantages and disadvantages of three grazing management systems are listed on the following page.

## Grazing Management Systems

### Continuous grazing

is a one-pasture system where livestock have unrestricted access throughout the grazing season.

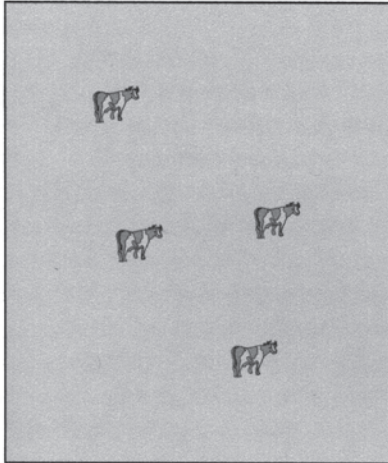

#### Advantages

- Requires less management
- Capital costs are minimal

#### Disadvantages

- Lower forage quality and yields
- Lower stocking rate and less forage produced per acre
- Uneven pasture use
- Greater forage losses due to trampling
- Animal manure is distributed unevenly
- Weeds and other undesirable plants may be a problem

### Simple rotational grazing

is a system with more than one pasture in which livestock are moved to allow for periods of grazing and rest for forages.

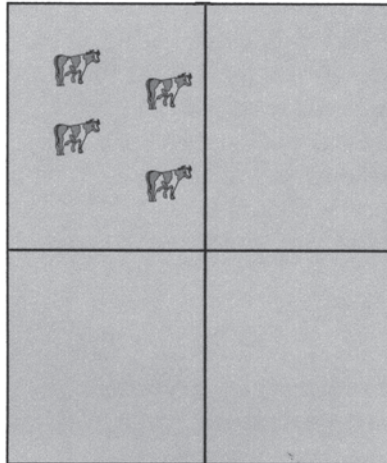

#### Advantages

- Can increase forage production and improve pasture condition over continuous grazing
- Allows pastures to rest and allows for forage regrowth
- Can provide a longer grazing season, reducing the need for feeding harvested forages
- Better distribution of manure throughout the pasture

#### Disadvantages

- Costs for fencing and water systems can be higher than with continuous grazing
- Forage production and pasture utilization is not as high as intensive rotational grazing systems

### Intensive rotational grazing

is a system with many pastures, sometimes referred to as paddocks. Livestock are moved frequently from paddock to paddock based on forage growth and utilization.

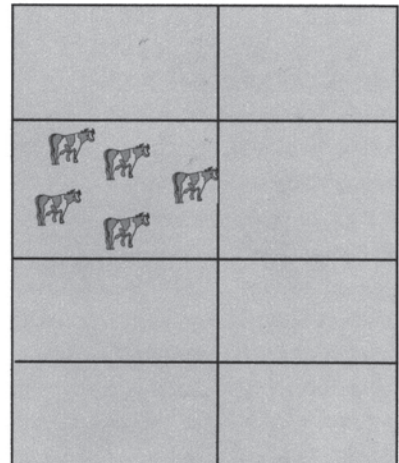

#### Advantages

- Highest forage production and use per acre
- Stocking rates can typically be increased
- More even distribution of manure throughout the paddocks
- Weeds and brush are usually controlled through grazing
- Provides more grazing options and reduces the need for mechanically harvested forages

#### Disadvantages

- Requires careful monitoring of forage supply
- Initial costs may be higher due to fencing materials and water distribution systems
- Requires more management

# Grazing Resource Inventory

## Goals

### What are my goals for the grazing system?

Establish well-thought-out goals to direct the development of a grazing plan. The goals on which to base future business, management, and production strategies will be unique to your own operation.

Examples of goals include:

- Increase livestock numbers and/or forage availability
- Improve animal performance
- Reduce feed costs or labor
- Reduce soil erosion

Annually, goals should be reviewed and updated to fit the current situations and needs of the farm. After making a list of what you want to achieve with the resources you have available, you are now ready to look at the management options to accomplish your goals.

## Land and Soils

### What land resources are available for the grazing operation?

**Locate or draw a map showing the boundaries of the land that is available for grazing.**

Distinguish land that is owned from land that is rented. There are certain management practices that you can apply to your own land that you may not be able to do on rented land. Determine the number of acres of the different land parcels and label these on the map (Diagram 1).

Is there additional land available that could be used for grazing? Often, cropland that is adjacent to pasture land may be better utilized by growing forages. Cropland in close proximity to existing pastures is ideal for converting to grazing if pasture expansion is one of the farm goals. Identify and label on the map cropland that could be used for grazing.

### What is the productivity of the soils?

**Map soil types and soil fertility of your pastures.** Soils vary considerably in their ability to support plant growth. Soil productivity is partially determined by its ability to hold water and nutrients and release them to the plant, and by how well plant roots can grow in the soil. Actual crop yields achieved are a result of the interaction between soil productivity, the level of management, and climatic factors (Diagram 2).

Diagram 1. Land resources map

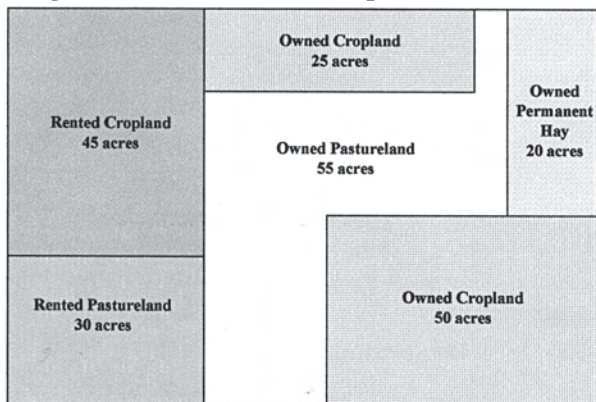

*Aerial photos from USDA-Farm Service Agency provide a good base map*

Diagram 2. Soils map

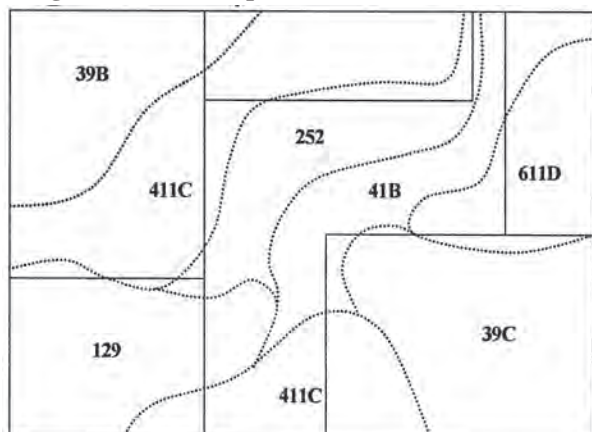

## Legend

Map Symbol	Soil Name	Slope (%)	Estimated Yield (tons/acre)	
			Grass/Legume	Kentucky Bluegrass
39B	Wadena Loam	2-6	4.0	1.7
39C	Wadena Loam	6-12	3.6	1.5
41B	Esterville Sandy Loam	2-6	2.6	1.2
129	Cylinder Loam	0-2	4.0	1.7
252	Marshall Silty Loam	0-2	4.6	2.0
411C	Waukegan Silt Loam	6-12	3.8	1.8
611D	Hawick Loamy Sand	12-18	2.0	0.5

A County Soil Survey is a good first step for determining soil types in your pastures. The publication contains general characteristics of each soil type, including soil texture, drainage, water holding capacity, and organic matter content. Estimated forage yields can be calculated from “Pastures for Profit” (see References section), Appendix A, the local NRCS Forage Suitability Groups, or farm records.

**Are there sensitive land areas or soil limitations for grazing in the pasture?**

Sensitive land areas are areas that have a high potential to generate or transport unwanted materials towards ground or surface water. The types of materials that could contaminate these resources are bacteria, nutrients from livestock manure, and sediment resulting from soil erosion (Diagram 3).

Examples of sensitive land areas to be identified and referenced on a map:

- Location of surface waters (wetlands, lakes or streams)
- Quarries, mines or sinkholes
- Active or abandoned water supply wells
- Coarse-textured and high-leaching soils
- Steep slopes
- Shallow soil to a water table or bedrock
- Wooded areas
- Intermittent waterways

Limiting features also need to be identified and referenced on a map. The most important source of information is observed by walking the pasture with somebody that is knowledgeable in soils and soil management. The Soil Survey publication for your county will also provide additional information on pasture features found below the soil surface.



Examples of soil limiting features:

- Sandy soils which have a high potential for drought
- Shallow soils over bedrock that limit the depth of root growth
- Flood-prone soils that either restrict growth of certain forages or limit grazing time
- Organic soils which limit accessibility and ability to withstand traffic
- Extreme slopes or landscapes that make pasture areas difficult to reach

*County soil information and maps can be obtained from your local USDA Agricultural Service Center or Extension office.*

*For help identifying these areas of your pasture, contact your local USDA Agricultural Service Center or Extension office.*

**Diagram 3. Sensitive areas and soil limitation area map**

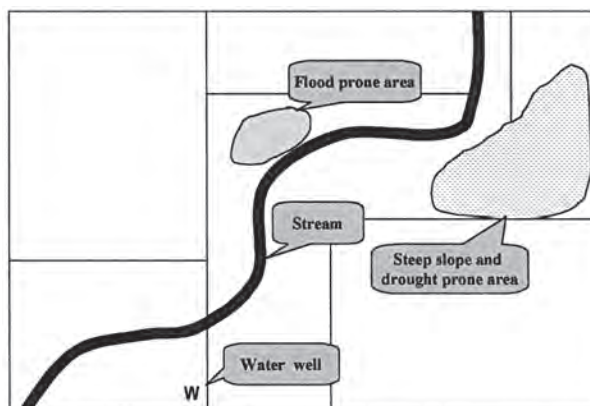

## Livestock

### What are the forage requirements for each livestock herd?

**First**, estimate the daily requirement for your herd:

$$(\# \text{ of animals}) \times (\text{average weight}) \times (\text{daily utilization rate}) \\ = \text{daily forage requirement}$$

**Daily utilization rate** = 0.04. This figure is used because livestock need to have access to approximately 4% of their live weight in forage (2.5% intake, 0.5% trampling loss, and 1% buffer).

Example:

$$(25 \text{ cow/calf pairs}) \times (1,200 \text{ lb. average weight}) \times (0.04) = 1,200 \text{ lbs/day}$$



The daily forage requirement is used in Section 3, **Grazing Plan Development, Paddock Design and Layout**.

**Second**, estimate the monthly and seasonal requirements for your herd:

$$(\text{daily forage requirement}) \times (\# \text{ of days per month}) \\ = \text{monthly forage requirement}$$

Example:

$$(1,200 \text{ lbs/day}) \times (30 \text{ days}) = 36,000 \text{ lbs. monthly forage requirement}$$



$$(\text{daily forage requirement}) \times (\# \text{ of days in the grazing season}) \\ = \text{seasonal forage requirement}$$

Example:

$$(1,200 \text{ lbs/day}) \times (150 \text{ days}) = 180,000 \text{ lbs. seasonal forage requirement}$$



The **Livestock Forage Monthly Balance Sheet** (Table 1 and Appendix A) provides a simple method of computing monthly forage requirements.

Remember, the primary goal of most livestock grazing systems is to produce weight gain on the livestock. An increase in animal size will result in an increase in estimated forage needs through the grazing season as long as animal numbers do not change. Adjust livestock weights for each month to provide a more realistic estimate of forage needs.

**Table 1. Livestock Forage Monthly Balance Sheet – Current Livestock Summary**

Kind/Class Livestock	Number of Animals	Average Weight	Monthly Utilization*	Forage Requirements Per Month (lbs. x 1000)					
				May	June	July	Aug	Sept	Oct
Beef cow/calf	25	1200	1.2	36.0	36.0	36.0	36.0	36.0	36.0
Herd bull	1	2000	1.2			2.4	2.4	2.4	2.4
Totals	26			36.0	36.0	38.4	38.4	38.4	38.4

\* 0.04 daily utilization rate (includes forage waste) x 30 days/month

## What are the plans for potential expansion of the livestock operation?

If an increase in herd size is a goal of the operation, estimate what adjustments to forage will be needed and consider how to best meet those needs with forage supply. Are there enough acres in the existing pasture to meet the needs of the larger livestock herd? What is the potential forage supply if improvements are made to the pasture or grazing system? This issue will be addressed in following section on forages.

## How many herds will be grazed?

Separating the grazing herd into groups based on production, animal species, animal size, or class differences should be examined. When there is an increase in the number of herds, you will need to increase the number of paddocks. When dividing the pasture consider:

- How many groups could potentially be grazing at the same time?
- Can the different groups graze next to each other? (Don't place male animals in paddocks adjacent to females in heat.)

## Forages

### What are the existing forage species in the pasture?

Forage grass and legume species each have their own unique growth, persistence, and quality characteristics. Because they respond differently to soil conditions, weather patterns, fertility, and grazing management, the plants that are currently growing in your pastures may be different from one area to another. **Identify dominant plant species and areas in which they grow on your pasture map.** A walk through the pastures is necessary to gather this information. The plants you find during the initial inventory of your forage species may or may not be the desired species for meeting the long-term goals of your grazing system. Therefore, information on forage species growing in the pasture may have an impact on future modifications to the grazing system (Diagram 4). Identification keys for grass and legume species are readily available in Appendix B. Grass species are often difficult to identify during early stages of growth. Still, there is a need to distinguish between grass species because of potential differences in forage yield and seasonal growth patterns.



*Assistance in identifying your forage species can be obtained at your local USDA Agricultural Service Center or Extension office. To collect plant samples for later identification, dig several plants along with roots, and place them between sheets of newspaper. Remove all soil from the roots before placing on the newspaper. To aid the plant drying process, apply an even pressure or weight to the newspaper.*

Diagram 4. Forage map

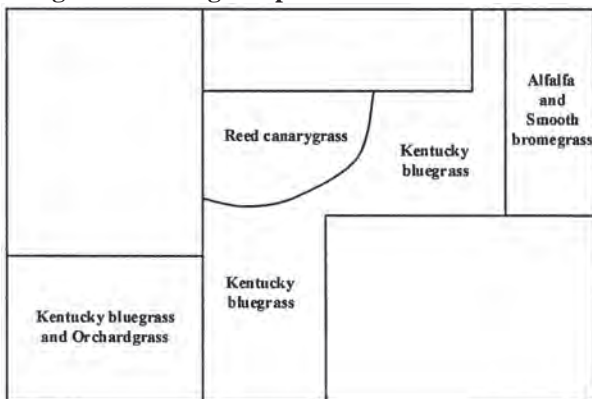

## How healthy or in what condition is the pasture?

Good pasture condition is critical to a successful grazing system. Pasture quality may vary greatly from one pasture area to another, but the trend over time should show the direction in which the pasture condition is moving. Determining Grassland Condition/Trend (Appendix C1) is an evaluation tool to help determine if pastures are in need of improvement and what areas need the most improvement. It is also a useful tool in evaluating results of management decisions. **Determine the condition of your pastures by completing the Determining Grassland Condition/Trend sheet** (an example of a completed form is provided in Table 2).

## What are the estimated yields and seasonal distribution of the existing forages?

Based on the plant species, pasture condition, and soil types found in the pastures, forage yields and overall forage supply can be estimated for your grazing system. **Document the forage yields in lbs./acre on the Livestock Forage Monthly Balance Sheet** (example of completed form is provided in Table 3). Remember these are only estimates to provide a starting point for future planning. Changes in climatic conditions from one year to the next can drastically change forage production and the outcome of seasonal forage supply.



**Table 2. Determining Grassland Condition/Trend**

	Field #					Rented	Owned			
	Acres					30	55			
	Month & Year					M__Y__	M__Y__	M__Y__	M__Y__	M__Y__
Category	Score					Value	Value	Value	Value	Value
1) Species Composition	Undesirable		Desirable			2	1			
	0	1	2	3	4					
2) Plant Diversity	Narrow			Broad		1	1			
	0	1	2	3	4					
3) Plant Density	Sparse			Dense		2	2			
	0	1	2	3	4					
4) Plant Vigor	Weak			Strong		1	1			
	0	1	2	3	4					
5) Legumes in Stand	Less than 10%			More than 40%		0	0			
	0	1	2	3	4					
6) Plant Residue	Deficient	Appropriate			Excess	2	2			
	0	2	4	2	0					
7) Uniformity of Use	Spotty	Intermediate			Uniform	3	2			
	0	1	2	3	4					
8) Severity of Use	Heavy	Moderate			Light	0	0			
	0	2	4	2	0					
9) Woody Canopy	More than 40%			Less than 10%		4	4			
	0	1	2	3	4					
10) Soil Erosion	Severe	Moderate			Slight	2	1			
	0	1	2	3	4					



Once the forage species and yield estimates have been documented, a monthly forage supply can be determined using the estimated forage production and seasonal distribution percentages. For specific forage yields and seasonal distribution using charts from “Pastures for Profit,” Natural Resources Conversation Service (NRCS) Field Office Technical Guide tables, or information in Appendix D. The estimated monthly values follow the seasonal growth patterns of the common forage species. This exercise provides a good estimate of the total amount of forage available to livestock for any month of the grazing season. Subtract the monthly requirement from the monthly forage production to:

- Indicate forage balance for the growing season
- Predict excess forage production by month
- Predict where forage shortages may occur by month

Using the information in Appendix D, net yield and monthly available forage for orchardgrass in a pasture that is in poor condition can be calculated.

*Forage yield estimates for your grazing system can be found in any of the following publications:*

- *The County Soil Survey*
- *NRCS Field Office Technical Guide*
- *Pastures for Profit; A Guide to Rotational Grazing, U of MN Extension Service*
- *Refer to Appendix D of this guide for yield estimates*

*Example:* Monthly available forage for orchardgrass in a pasture that is in poor condition is calculated in the following procedure:

**Total Yield**

$$(\text{forage yield}) \times (\text{acres}) = \text{forage production}$$

*Example:*

$$(2,500 \text{ lbs/acre}) \times (30 \text{ acres}) = 75,000 \text{ lbs of forage (dry matter basis)}$$

**Forage Availability Per Month**

$$(\text{total yield}) \times (\% \text{ forage available by month from Appendix D}) = \text{monthly available forage}$$

Month	% Forage Available*	Monthly Available forage (lbs./acre)
May	10%	(75,000 lbs. x .10) 7,500
June	30%	x .30 22,500
July	10%	x .10 7,500
August	20%	x .20 15,000
September	20%	x .20 15,000
October	10%	x .10 7,500

\* From "Pastures for Profit" and NRCS Field Office Technical Guide

**Table 3. Livestock Forage Monthly Balance – Current Forage Summary**

Field	Kind of Forage	Forage Yield (lbs./acre)	Acres	Total Yield (lbs./acre)	Forage Availability Per Month (lbs x 1000)					
					May	June	July	Aug	Sept	Oct
Rented	Orchardgrass	2500	30	75,000	7.5	22.5	7.5	15.0	15.0	7.5
Owned	Kentucky Bluegrass	1900	38	72,200	7.2	28.9	7.2	10.8	10.8	7.2
Owned	Reed Canarygrass	2700	17	45,900	9.2	13.8	9.2	4.6	6.9	2.3
<b>Total lbs. Forage Available (x 1000)</b>				<b>193.1</b>	<b>23.9</b>	<b>65.2</b>	<b>23.9</b>	<b>30.4</b>	<b>32.7</b>	<b>17.0</b>
<b>Total lbs. Forage Required by Livestock (x 1000)</b>				<b>225.6</b>	<b>36.0</b>	<b>36.0</b>	<b>38.4</b>	<b>38.4</b>	<b>38.4</b>	<b>38.4</b>
<b>Total lbs. of Excess or Deficiency (x 1000)</b>				<b>-32.5</b>	<b>-12.1</b>	<b>29.2</b>	<b>-14.5</b>	<b>-8.0</b>	<b>-5.7</b>	<b>-21.4</b>

## Water Sources

### What are the existing water sources and where are the drinking facilities?



Water is essential. Without an adequate supply of quality water, animal health, weight gain, or milk production can be negatively affected. **Locate on a map the water sources and drinking facilities that are currently available to the grazing herd (Diagram 5).** Note all possible sources such as streams, ponds, wells, or springs. By viewing these on a map, we can see how far livestock have to travel to receive water. Consider these questions when making decisions:

- Are there seasonal changes in the water supply? Shallow wells or small streams will often dry up during late summer or during times of drought.
- If water is being hauled to the animals, how much storage is available?
- Is a nearby source of electricity available?
- Will the existing water sources be able to accommodate a pumping system that does not require electricity?

Diagram 5. Existing water and fence location map

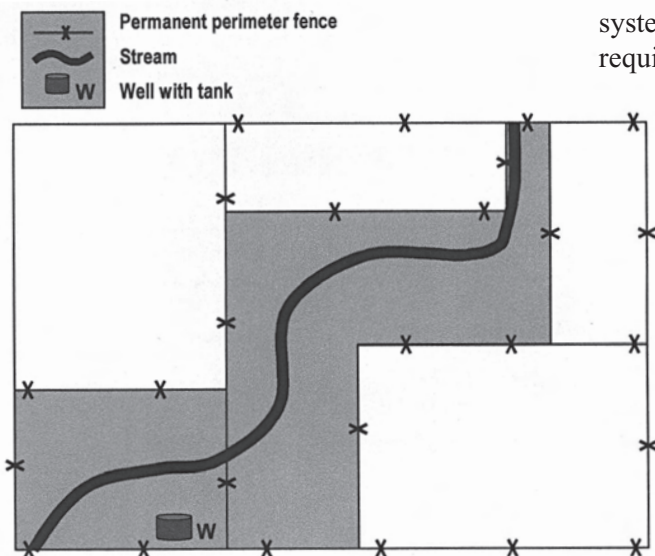

### What are the other potential water sources?

Changes to the grazing system may require making improvements to your livestock watering system. Are there other potential water sources that could be made available to the pasture? Do you need to drill a new well? Where is the best site for a new well? Is there a water source nearby where water can be obtained by constructing a pipeline system? These additional sources provide you with options when making decisions on improving your water system.

If you are not certain of the water quality, tests should be performed to determine whether the water is satisfactory for consumption by livestock. Good, clean water is especially critical to producers who expect high animal performance – as with milking cows, stockers, and replacement dairy heifers – although benefits are realized for other classes of livestock as well.

## Fencing

### What are the types and condition of the existing fences?

Know the kind and condition of existing fences. **Map the location of these fences including both perimeter and interior fences (Diagram 5).** Will the condition and location of the existing fence meet the needs of the grazing system? Should you plan to improve or change the location of any of the fences? Do not be locked in on the location of existing fences. Are there other livestock handling facilities available such as corrals, dry lots, barns, or sheds that are part of the pasture or grazing system?

# Grazing Plan Development

## Paddock Design and Layout

The development of a grazing plan involves the following:

- Determining how many paddocks are required and their size and shape
- Determining the kind of fence and locations
- Determining how water will be provided to the livestock

### How many paddocks are needed for a rotational grazing system?

The *minimum* number of paddocks in a system is dependent upon the length of the rest period that is required for the forages. The lengths of the rest periods for grasses and legumes can be found in Table 4. The rest period allows time for the forage plants to regrow, producing forage for the next grazing cycle. The length of the rest period varies throughout the growing season. When preparing your plan, use an average length or longer length of time (25-30 days). Using less than the average length of time will result in a plan with too few paddocks or paddocks that are too large.

Another component used in determining the number of paddocks is the grazing period. The length of the grazing period in each paddock is based upon the desired level of management, availability of labor, performance objective for the livestock, and growth characteristics of forages.

Grazing periods longer than 6 days will damage new regrowth. The grazing of new growth diminishes the ability of the forage plants to regrow quickly, resulting in an overall yield reduction for the pasture. A shorter grazing period is associated with livestock operations where livestock performance is essential, such as with milking cows. Longer grazing periods are more typical of beef cow/calf operations, ewe/lamb operations, and maintaining dry cows.



Table 4. Optimal rest period for forage species

Species	Cool Weather	Hot Weather
	(Days)	
Cool Season Grasses	14	35-50
Warm Season Grasses	35-40	21
Legumes	21-28	21-28

The *minimum* number of paddocks *for each herd* in the pasture system is equal to:

$$\text{Paddock Number} = \frac{\text{Rest period (days)}}{\text{Grazing period (days)}} + 1$$

Guidance on paddock management is provided in the *Pasture Management* section

The required size of the paddock for average growth conditions is equal to:

$$\text{Paddock Size} = \frac{(\text{daily herd forage requirement}) \times (\text{days in grazing period})}{(\text{lbs. forage available per acre})}$$

<b>Daily herd forage requirement</b>	Total weight of the herd times 0.04 utilization rate (refer to the livestock inventory from Table 1).
<b>Grazing period</b>	Length of time animals are in paddock.
<b>Pounds of forage available per acre</b>	Measured height of forage minus minimum stubble height (from Table 5) x pounds of forage per acre per inch of height (from Table 6).

**Table 5. Minimum height (in inches) of pasture species for initiating and terminating grazing**

Species	Begin Grazing		End Grazing	
	Initial Grazing Height in Early Spring*	Minimum & Optimum Height of Vegetative Growth	Minimum Stubble Height**	Minimum Regrowth before Killing Frost
Alfalfa		Bud Stage	-	6***
Creeping Foxtail	6	8-10	3	6
Green Needlegrass	4-5	6-8	3	5
Inter. Wheatgrass	4-5	8-14	4	6
Kentucky Bluegrass	2	4-6	2	4
Orchardgrass	3-4	6-10	3	6
Perennial Ryegrass	3-4	5-7	3	4****
Pubescent Wheatgrass	4-5	8-14	4	6
Reed Canarygrass	4-5	8-8	4	6
Russian Wildrye	4	5-7	3	4
Slender Wheatgrass	4-5	6-12	3	6
Smooth Brome	4	8-14	4	6
Tall Fescue	4	6-10	3	6
Tall Wheatgrass	4-5	8-14	4	6
Timothy	4	6-10	4	5
Western Wheatgrass	4	6-10	4	5
Big Bluestem		10-14	6	6
Indiangrass		10-14	6	6
Little Bluestem		5-7	3	4
Sand Bluestem		8-14	6	6
Sideoats Grama		5-7	3	4
Switchgrass		12-20	8	10

Source: Minnesota NRCS Conservation Practice Standard #528A, Prescribed Grazing.

\* This applies only to the initial grazing in the spring (early May). The livestock must be moved rapidly through the paddocks during this time to prevent overgrazing and to keep the forage from "getting ahead of the livestock."

\*\* Minimum stubble height is critical if stand is to be maintained. This applies to that part of the grazing season after the initial rapid growth period in early May, as well as the end of the grazing season.

\*\*\* The last harvest of alfalfa for pasture or hay should generally be made 35-45 days prior to the time when the first hard freeze typically occurs.

\*\*\*\* Regrowth should be grazed to 2 inches after dormancy and prior to snow cover.

## How do I decide paddock size?

Paddock size is based upon providing an adequate supply of available forage to meet the requirements of the herd. This would be a simple task if the forages grew at the same rate throughout the season. We know this is not the case. For example, cool season grass growth is very rapid in the spring, slows considerably during the hot summer months of July and August, and increases somewhat again in the fall.

Clearly, for a given herd the area required to produce the necessary forage for the planned grazing period will not be the same throughout the grazing season. The strategy for dealing with this variability is this:

- Plan using average growing conditions.
- Vary the length of the grazing period throughout the grazing season when paddock size is fixed.
- Vary the size of the paddock when the size is not fixed, as in a strip grazing system.

The paddock size times the minimum number of paddocks provides us with the minimum required size of the total pasture unit. If the existing pasture is larger than this minimum area, more paddocks can be planned for. This will likely provide more than enough forage in the spring, some of which could then be harvested for hay. Having more paddocks than the required minimum will reduce the risk of running out of forage during the midsummer slump that cool season pastures normally experience.

If the acreage of the required minimum number of pastures is more than the existing pasture acreage, additional acreage should be devoted to pasture to avoid running out of usable forage during the midsummer slump.

### What are some considerations for paddock layout?

Some adjustments need to be made to the size of each paddock so they have equal productivity. The information gathered during the inventory process is useful when determining the paddock layout. Each paddock should have:

- Similar soils (refer to Diagram 2)
- Similar slope aspect (north facing, south facing, etc.)
- Similar topography
- Similar forages (refer to Diagram 4)

The shape of the paddocks is significant. Paddocks should be as square as possible to promote

more uniform grazing. Long, narrow paddocks generally are overgrazed at one end and underutilized at the other end. Paddocks should be planned so that livestock do not have to travel more than 800 feet to get water. This will encourage more water consumption by the livestock and more uniform grazing within the paddock. Livestock tend to utilize the forages close to water much more than forages farther from the water. Additional adjustments may be required based upon access to water sources, which may have an impact on the shape of the paddocks in a grazing system, particularly in situations where natural water sources, such as ponds and streams, are utilized.

Paddock layout will also be influenced by the location of lanes for the movement of livestock. These lanes should connect all paddocks so that livestock can be moved to any paddock from the one they currently occupy, allowing for maximum flexibility in forage management.

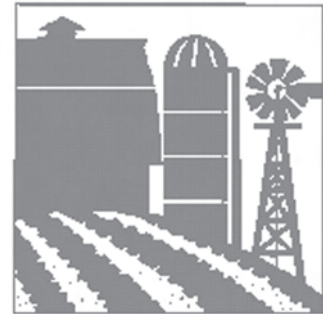

**Table 6. Estimated dry matter yield per acre-inch for various forages at three stand densities**

Forage	Stand Density <sup>1</sup>		
	Fair*	Good**	Excellent***
	<b>lb. Dry matter/acre-inch</b>		
Bluegrass/White Clover	150-250	300-400	500-600
Tall Fescue+Nitrogen Fert.	150-250	250-350	350-450
Tall Fescue/Legume	100-200	200-300	300-400
Smooth Bromegrass/Legumes	150-250	250-350	350-450
Orchardgrass/Legumes	100-200	200-300	300-400
Mixed Pasture	150-250	250-350	350-450
Alfalfa or Red Clover	150-250	200-250	250-300
Native Tall Warm-Season Grasses	50-100	100-200	200-300

Source: USDA-NRCS (MN)

<sup>1</sup>Stand condition is based on visual estimate of green plant ground cover after being grazed to a 2-4 inch stubble height.

\* Fair Condition: Less than 75% ground cover or greater than 25% bare ground.

\*\* Good Condition: 75-90% ground cover or 10-25% bare ground.

\*\*\* Excellent Condition: At least 90% ground cover or less than 10% bare ground.

# *Fence Design and Layout*

## **What kind of fence should I install?**

The kind of fence that should be installed depends upon:

- Purpose of the fence
- Kind and class of livestock to be contained
- Operator preference
- Predator control
- Cost

Permanent or temporary fences may define paddocks within the grazing unit. During initial stages of paddock layout many producers prefer to use temporary fences to create paddocks and lanes. This allows for easy adjustment of the layout as producers learn what size paddock they need, how to easily accomplish livestock movement, and how forages react to managed grazing. After gaining experience, the producers usually install some type of permanent fence to define paddocks and lanes.

### **A. Permanent Fences:**

Permanent fences are used for the perimeters of pasture systems, livestock corrals, and handling facilities. Sometimes they are used to subdivide pastures into paddocks. This is especially true for certain kinds and classes of livestock, such as bison.

#### **1. High Tensile Wire Fences**

This is a relatively new type of fence, which has become increasingly popular in recent years. Typically perimeter fences are 4-6 strands of wire and interior fences are 1-2 strands of wire.

##### **Advantages:**

- Relatively easy to install and maintain.
- Can be powered to provide a psychological as well as physical barrier.
- Several contractors available to do installation.

##### **Disadvantages:**

- Requires some special equipment, such as a post driver for installing wooden posts.
- Fences with several strands of wire are not easily moved.
- Wire is difficult to handle if fence is to be moved.

#### **2. Woven Wire Fences**

Woven wire is a traditional type of fence. It is used primarily for hogs and sheep. Woven wire fences normally have one or two strands of barbed wire installed above the woven wire.

##### **Advantages:**

- Not dependent on electrical power. Is useful in remote locations.
- Provides barrier for smaller kinds of livestock (sheep, hogs).

##### **Disadvantages:**

- Cannot be powered, provides only a physical barrier.
- Requires much labor to install.
- Not easily moved.
- Weed and vegetative growth promotes snow piling.

#### **3. Barbed Wire Fences**

Barbed wire is a traditional type of fence, which is still quite popular. Barbed wire fences should be at least 4 strands for perimeter fences. When used for interior fences, they are typically 3 or 4 strands. Barbed wire should never be electrified because of greater potential for animal injury.

##### **Advantages:**

- Not dependent upon electrical power, thus is useful in remote areas.
- Most producers are experienced with construction of barbed wire fences.

##### **Disadvantages:**

- Not easily moved.
- Provides only a physical barrier.
- Susceptible to damage from snow accumulation.

### **B. Temporary Fences:**

The primary uses of temporary fence are to define paddocks within a pasture system, direct the grazing within a paddock to areas that are being underutilized, and to fence in areas that are grazed only occasionally or not part of a regularly-rotated pasture system.

Temporary fences are usually constructed with step-in posts and polywire, polytape, light gauge steel or aluminum wire, and require an electrical source. Easy and quick to move, these fences do not require tools for setup. In addition, these fences are very light and do not require bracing.

**Advantages:**

- Easy to install and to move.
- Relatively inexpensive.
- Provides considerable flexibility.
- Can be used within permanently established systems to direct grazing pressure.

**Disadvantages:**

- Components have relatively short lifespan.
- Not suitable for perimeter fences.
- Provides a psychological barrier only, not a good physical barrier.
- Requires an electrical source and maintenance of the fence line from electrical grounding.

## ***Water System Design and Layout***

### **How can I supply adequate water to the livestock?**

Water is essential for livestock to effectively process forages. A well-planned and installed water system will provide an adequate quantity of water with minimal disturbance to the soil resource and to the water source itself.

Common sources of water for livestock are streams, ponds, lakes, and wells. Of these sources, well water is preferred because it is cleaner. Research shows that there can be a significant increase in animal performance and improved herd health if the drinking water is clean and free from sediments, nutrients, pesticides, algae, bacteria, and other contaminants.

Alternative methods of delivering the water to the livestock include:

- Ramps to surface water (ponds, etc.)
- Livestock powered pumps
- Solar pumping systems
- Sling pumps
- Hydraulic ram pumps
- Gasoline powered pumps
- Water hauling

These methods can be used to discharge directly into a trough or tank, but normally a pipeline is installed to distribute the water to drinking facilities available

in all paddocks. When using a pipeline to deliver water you may need to have a system that is engineered to meet the specific needs of your site. See Appendix E for description of pumping systems.

Considerations in designing a pipeline system include:

- Quantity of water to be delivered
- Pressure differences due to elevation changes
- Length of pipeline
- Protection from freezing

### **Where should drinking facilities be located?**

Drinking facilities should be available in each paddock. If possible, locate drinking facilities so that livestock do not have to travel excessive distances to drink. In systems where livestock must travel long distances to water, forages tend to be overutilized near the water, and underutilized in areas of the paddock that are farthest from the water. Other problems associated with this situation include uneven manure distribution in the paddock and diminished animal performance.

Most livestock watering systems consist of a pump, a delivery system (usually a pipeline), and a trough or tank for the livestock to drink from. Once the paddock layout is established, and the water sources identified, the delivery system must be accommodated. If water is to be hauled, access by the tanker needs to extend to each storage tank. If the water is to be delivered through a pipeline, the route must be determined so that each paddock in the system has access to the water. The pipeline layout should follow the shortest route to minimize cost and maintenance problems. This will ultimately determine the general area in which the watering tanks will be placed.

Water tanks should be placed on soils that can support heavy traffic and provide easy access by livestock without crowding. Permanently installed tanks should have some type of heavy use treatment around them to prevent the formation of a mudhole. Refer to the following section on **Heavy Use Area Planning**. Portable tanks offer the most flexibility. Their location can be changed frequently by adding a length of pipeline between the coupler and the tank and placing the tank in a different location. The tanks can be moved as often as necessary to manage grazing and avoid creation of barren areas and mudholes.

*For technical assistance in designing your watering system, contact your local NRCS Field Office.*

## Heavy Use Area Planning

Some areas of the pasture system will be used so much that the best option is to place some type of protective material to prevent the formation of mudholes. Two such areas are those that surround watering facilities and the alleyways used for livestock movement.

*When using portable tanks, allow for 2 tanks per herd so that one water tank can be set up ahead of time in the next paddock.*

*See your local NRCS office for design assistance for stream crossings, unstable sites, and drinking facility pads.*

*Lanes for livestock do not work well for bison. They do not like to be confined to narrow areas. If lanes are used for bison, make them much wider than they would be for other kinds and classes of livestock.*

*For more information on Geotextiles read "Using All-weather Geotextiles for Lanes and Paths." Midwest Plan Service publication AED-45.*

### What do I consider when planning livestock lanes?

Livestock movement must be controlled for a successful grazing system. Lanes that are properly planned will allow for livestock movement from one paddock to any other paddock without moving back through a recently grazed paddock. Livestock will tend to stop moving when they go into a paddock with some fresh forage growth, even though you may want them in a different paddock. Lanes prevent this from happening. The areas within the lanes can normally be grazed along with an adjacent paddock, unless the lane is covered with some type of protective material. The locations of livestock lanes should avoid potential erosion, concentrated water flow, and flooding. Avoid placing lanes up and down hills, in wetlands, or on organic soils.

### How do I stabilize the livestock lanes?

Livestock lanes should be protected with lime screenings or some other fine textured material to prevent mudhole development and erosion when:

- There is considerable animal traffic, as in the case of milk cows using the lane for two round trips each day
- Areas of the lane are subject to erosion

Fine-textured materials are preferred over course-textured materials because the course-textured material can injure the feet of livestock. If animals must traverse lanes that are in unstable areas, such as wet draws, then the treatment described below for protecting watering facilities should be installed to avoid difficulty with livestock movement.

### How do I keep the area around water facilities from becoming mudholes?

Watering stations that are permanently placed will be subject to heavy use since they are often used to provide water for more than one paddock. Water spillage and leakage, which is inevitable, adds to the mud problem. As a consequence, protective materials will need to be used around watering sites. Portable watering tanks will not generally have the same problems because they can be moved around to spread the use over a larger area.

The recommended method of building pads for water stations is to:

- Prepare a good subgrade by removing debris and vegetation along with at least 8" of topsoil
- Compact the subgrade
- Lay down a geotextile fabric (Class I)
- Place a six-inch layer of course aggregate on the geotextile fabric and top with a three-inch layer of fine aggregate
- Lanes generally need to be 12-15 feet wide and pads around tanks need to extend out 20-25 feet



# Pasture Management

## *Pasture Forage and Livestock Management*



### What is proper grazing management for the desired forage species?

To maintain desirable plants for grazing, pasture management must provide adequate rest from grazing in order to give desired species the competitive edge over less desirable plants. A good mix of desired plants within the pasture also benefits the grazing system by providing more ground surface coverage by plants for as many days of the year as possible. Mixtures of grass and legume species that have different growth curves in the same pasture provide greater forage productivity than a single species pasture.



Are the pasture forages adequate to meet the needs of the livestock or are there areas that need improvement? Using the completed **Determining Grassland Condition/Trend**

worksheet from the Forage section of Chapter 2, evaluate your pasture. Generally, if the pasture plant population and plant diversity are at a high level but plant vigor is weak, a change in grazing system management to provide a rest period may be all that is needed to increase forage production. In contrast, if plant population is undesirable and plant diversity is low, then establishment of new seedings of desirable plants could add additional forage for the pasture.

The decision to renovate a pasture and establish new forage species or add to the existing forage plants should be well-planned. Should you establish a legume component, grass-legume mixture, or a more productive grass in the pasture? Before purchasing seed, consider economics of the intended management practice, animal preference for forages, soil conditions, and landscape of the site.

### How do pasture and livestock management affect plant growth and forage quality?

The basis of forage production is to harvest sunlight and rain to produce healthy forage plants for animals to graze. To be healthy and vigorous, plants need an extensive, healthy root system. There is a direct relationship between root growth and the amount of leaf area developed. If too much of the leaf area is removed, roots will die back. When management limits the removal of forage to no more than 50 - 60%, root growth will not be significantly reduced. Plants will remain healthy and leaf regrowth will be fairly rapid. This growth rate response is illustrated in Figure 1.

Figure 1. The growth rate curve and three phases of pasture growth

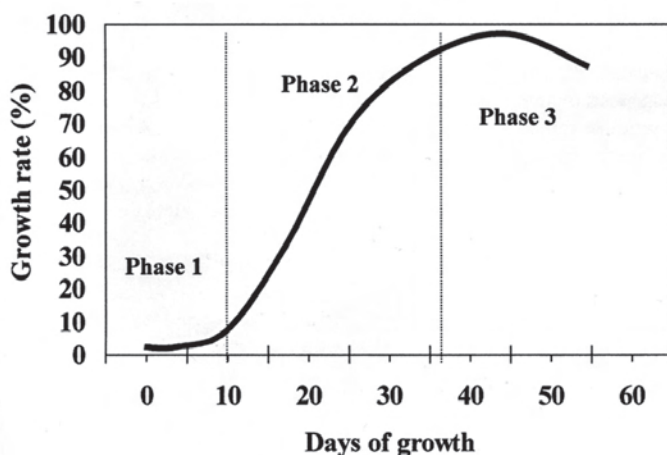

The growth curve is divided into three phases. Plant growth is slowest during Phase 1 when plants are small and there is insufficient leaf area to intercept light for growing leaves and to maintain roots. Root growth stops during Phase 1. Grazing during this time will provide high quality but low yielding forage. However, continued grazing during this phase will cause plant vigor to weaken because of reduced root growth. The loss of an extensive root system ultimately results in lower forage yields because the plant's ability to take up water and nutrients are reduced.

Growth rate increases when enough leaves are present to maintain existing leaves and roots and also promote growth of new leaves as occurs in Phase 2. Leaves during this growth phase intercept more sunlight than is needed for maintaining the plant and as a result the rest of the energy is used to rapidly develop new leaves and roots. Grazing during Phase 2 provides the optimum balance of forage yield and quality. The goal is to begin grazing a particular paddock when forage growth is high on the Phase 2 curve and then remove the livestock near the transition from Phase 1 to Phase 2. Nutritional needs of the livestock will determine where on the growth curve to start grazing a paddock. Livestock with a high nutritional requirement, such as milking cows or stockers, should be moved to high quality forage more frequently and will require forage growth that is lower on the Phase 2 curve. Livestock with lower nutritional requirements, such as beef cows, can be kept on a paddock for a longer time and

can graze starting high on the Phase 2 curve and end when growth is low in that same phase.

During Phase 3, growth rate slows down as plants mature. Most of the plant's energy is going into seed production or maintenance. Grazing during Phase 3 will provide high yields, but low quality forage will limit performance of most livestock. Only livestock with low nutritional needs such as dry cows or dry ewes will have most of their nutritional requirements met during this growth phase.

### When do I start grazing in the spring?

When to allow livestock to start grazing in the spring depends on what you are trying to accomplish. For most grazing operations, managing the early spring growth of forages is the primary consideration in deciding the appropriate time to start the grazing season. Because forage growth of cool-season species can be very rapid in the spring, forage production can easily outpace what livestock are able to consume. As a result, forage quality will decline rapidly in the pasture.

The decision on when to start grazing in the spring is a compromise between maintaining enough growing plant material in the pasture to promote rapid regrowth from healthy plants and keeping forage growth from outpacing the livestock. Because of rapid forage growth, recommended plant heights for initiating grazing in the spring are less than the heights recommended for the rest of the grazing season. Table 5 provides the recommended plant heights for

when to initiate grazing in the spring. Grazing forages starting at these heights and for short time periods (no more than 2 days) in a paddock system will provide higher quality feed for later in the season.

Livestock movement during the spring is another important consideration that will affect the balance between maintaining a rapidly growing, healthy pasture and maintaining quality forage for later in the season. Livestock will need to be rotated through the paddocks at a faster pace than typically averaged for the rest of the grazing season. When initiating grazing the forage production is low but dry matter is accumulating rapidly. For livestock to be rotated through all the paddocks before forage growth outpaces consumption, the time spent on an individual paddock will need to be kept short. Clipping or harvesting hay in some paddocks can maintain forage quality if grazing does not keep ahead of the spring growth forage quality.



**When do I move livestock from paddock to paddock?**

Movement of livestock through paddocks in the early spring is discussed in the previous section. Once forage growth begins to slow (normally in late May) the movement of livestock is based upon the amount of forage available and the minimum stubble heights shown in Table 5.

Grazing should be terminated in a paddock when the livestock have grazed the forage down to the minimum stubble height.

A paddock is not ready to graze until the forage has reached the minimum height shown in Table 5, in the column labeled “Minimum and Optimum Height of Vegetative Growth.”

Not every paddock will yield the same quantity of forage due to differences in soil conditions and landscape. Knowing how much forage is produced or available in each paddock is important. The following equations and tables determine how many animals will be needed to utilize the forage in a given period of time, and how much time a given number of animals will be able to graze a paddock.



**A. How many animals will a particular paddock support?**

The following equation calculates the number of animals a particular paddock will support:



$$\text{Number} = \frac{(\text{pounds of forage/acre}) \times (\# \text{ of acres})}{(\text{individual animal weight}) \times (\text{utilization rate}) \times (\text{days})}$$

Example:

$$\frac{(1200 \text{ pounds/acre yield}) \times (8 \text{ acres})}{(1200 \text{ pounds/animal}) \times (.04) \times (4 \text{ day grazing period})} = 50 \text{ head}$$

<b>Pounds of forage/acre</b>	Table 6 x inches of usable forage
<b>Number of acres</b>	Acres in a specific paddock
<b>Individual animal weight</b>	From Livestock Inventory
<b>Utilization Rate</b>	0.04 represents forage intake, trampling and buffer
<b>Days</b>	The planned length of grazing period for the paddock

**B. How many days can my herd stay on a paddock?**

The following equation calculates the number of days a paddock will support a herd:

$$\text{Days} = \frac{(\text{pounds of forage/acre}) \times (\# \text{ of acres})}{(\text{daily herd forage requirement})}$$

For paddock management it is important to be able to estimate the quantity of forage on a paddock at a given time. This is especially important just prior to

moving livestock into a paddock. Table 6 indicates forage quantity based on forage species, height of growth, and pasture condition.

Example:

$$\frac{(1200 \text{ lbs/acre yield}) (8 \text{ acres})}{(42,000 \text{ lbs}) (0.04 \text{ utilization rate})} = 5.7 \text{ days}$$

<b>Pounds of forage/acre</b>	Table 6 x inches of usable forage
<b>Number of acres</b>	Acres in a specific paddock
<b>Daily herd forage requirement</b>	Total herd weight x 0.04 utilization

There should be some residual stubble left in the paddock. The height of the stubble recommended for common grass species is given in Table 5. Subtract the required stubble height from the total forage height when computing pounds of forage available.

Growing conditions can change dramatically through the season, which will affect plant growth. For this reason, management must be flexible and not follow a set rotation pattern when moving animals. Movement of livestock from one paddock to another should be based on the height and the availability of forage. Grass and legume mixtures should be grazed in a manner that favors the dominant or desired species. The equations and tables referred to in this section provide estimates of available forage and how long livestock can graze an area. These are only estimates for planning. Actual decisions should be based on routine pasture observations. A successful rotational grazing system requires continuous monitoring and adjustment to balance the needs of both the plants and livestock.

## ***Pasture Soil Fertility Management***

Proper fertilization of pastures allows for good stand establishment, promotes early growth, increases yield and quality, and improves winter hardiness and persistence. Adequate fertility also improves the ability of grass and legume to compete with weeds, and

increases resistance to insects and diseases. Fields differ in their fertilizer needs. Take soil samples from representative areas to determine fertilization and liming requirements when converting to a rotational grazing system. Soil testing is the easiest and least expensive way to evaluate soil fertility and accurately assess if fertilizer is needed.

### **Can nutrients from livestock manure be utilized more efficiently in pastures?**

Nutrients are primarily removed from pasture ecosystems by making hay. Animals also remove nutrients through grazing. When pastures are grazed, many of the nutrients are returned to pastures via urine and feces. About 60-80% of the nitrogen, 60-85% of the phosphorus, and 80-90% of the potassium are excreted in urine and feces. Manure also contains many micronutrients needed by pasture plants. If manure is evenly distributed throughout the paddocks, fertility can almost be maintained through natural nutrient recycling.

Often, a majority of the urine and feces is concentrated around water, shade, and other areas where livestock congregate. This concentration of manure can lead to nutrient deficiencies in other parts of the pasture. Not only does concentration of manure around water and shade sites lead to lower pasture productivity, it also leads to greater opportunity for nitrate contamination of surface and ground water.

To evenly distribute manure and increase soil fertility throughout the paddock, shorten the rotation, increase stocking rates, and place water, shade, salt, and supplemental feeders in nutrient-poor areas. Minimize the amount of time animals spend around water by assuring the cattle do not have to travel more than 600 to 800 feet in each paddock.

*For more detailed information on soil test recommendations, contact your local Extension office or USDA Agricultural Service Center.*

### When is increasing soil pH with lime important for forage production?

Overall, soil microorganism activity and plant nutrient availability are nearly optimum at a soil pH of 6.5 to 7.0. Lime applications should be made to increase soil pH to a level appropriate for the crop being grown. It is often best to grow species that are adapted to your soil pH (Table 7). Grass species are more tolerant of lower pH, whereas legumes need a more neutral pH. If the pasture planning strategy is to increase or introduce legumes into the pasture, correcting to the recommended soil pH is a must. Apply lime to the pasture following soil test recommendations. Surface applied lime will react slowly, so it should be applied 12 months before seeding.

### How much nitrogen fertilizer do I need to put on my pasture?

Nitrogen (N) is often the most limiting nutrient in the production of grass for pasture or hay. Grazing animals normally return 60-80% of available nitrogen back to the pasture. Additional N fertilization may be needed depending on your yield goals (Table 8). Nitrogen will not only improve dry matter yield, it will lead to increased plant crude protein content and dry matter digestibility if plants are grazed before they get too mature.

Since legumes can fix their own nitrogen from the atmosphere, pastures with more than 30% legumes rarely need additional N fertilizer. It is often reported that 80-100 lb. N/acre produced by the legumes is gradually available to the associated grass plants.

### Does phosphorus and potassium fertilizer improve pasture productivity?

Grasses may respond to phosphorus (P) and potassium (K) when nutrients limit plant growth. Phosphorus and potassium levels can increase seedling success by encouraging root growth. However, response to applied P and K is not usually profitable unless nitrogen supplies are adequate.

Legume-grass pastures have a higher requirement for P and K than do grass pastures. These two nutrients not only increase legume yields but also enhance disease resistance, winter hardiness, and stand life. Timing of application of P and K on legume-grass pastures is not critical; however, early spring or August applications are favored.

*If additional fertilizer is needed, the applicator should avoid spreading materials within 100 feet of permanent watering or shade sites because manure is often concentrated in these areas.*

**Table 7. pH recommendations for different forage crops**

Species	Optimum pH
Alfalfa	6.5 - 7.0
Smooth Bromegrass	6.0 - 7.0
Red Clover	6.0 - 7.0
Tall Fescue	5.6 - 7.0
Timothy	5.6 - 7.0
Switchgrass	5.6 - 6.5
Orchardgrass	5.6 - 6.5
Birdsfoot Trefoil	5.6 - 7.0

**Table 8. Nitrogen recommendations for various pasture management situations**

Expected Yield	Nitrogen Rate
tons dry matter/acre	lbs./acre
2	60
3	90
4	120
4+	150

Source: Fertilizer Recommendations for Agronomic Crops in Minnesota, University of Minnesota Extension Service, BU-06240-S, 2001

Applications can be made each year or you can double the rates and apply every other year. Tables 9 and 10 list the P and K recommendations based on soil test results.

### Pasture Brush and Weed Control

Weeds compete with desirable plants for water, nutrients and light. They can reduce yields of desirable species and can cause problems with animal health, animal weight, and/or milk production. Effective weed management begins with proper establishment of forage species that are adapted to soil, climate, and intended uses. Under these conditions, weeds can often be managed through appropriate grazing management and proper maintenance of soil fertility.

Broadleaf weeds tend to be the most troubling in perennial grass pastures. Many broadleaf weeds are on the noxious weed list and several are poisonous to livestock. These broadleaf weeds are generally less palatable, less nutritious, lower yielding and are less dependable as a forage supply for livestock. Weeds with known palatability problems include: musk, plumeless and bull thistle, nettles, absinth wormwood, perennial sowthistle, swamp smartweed, and common mullein.

### Can unwanted weeds be controlled through grazing?

Many weeds are unpalatable when mature but readily grazed when immature. Therefore, grazing practices can greatly influence whether weeds are routinely grazed or selectively passed over. Continuously

**Table 9. Phosphate fertilizer recommendations for grasses and grass-legumes grown for hay and pasture**

Expected Yield	Phosphorus (P) Soil Test (ppm)				
	Bray: Olsen:	0—5 0 - 3	6—10 4—7	11—15 8 - 11	16—20 12—15
ton/acre	P <sub>2</sub> O <sub>5</sub> to apply (lbs./acre)				
<b>Grasses</b>					
2	40	30	20	10	0
3	50	40	30	20	0
4	60	50	40	30	0
4+	70	60	50	40	0
<b>Grass-legumes</b>					
2	35	25	15	0	0
3	55	40	25	10	0
4	70	50	30	10	0
5	90	65	40	15	0

Source: Fertilizer Recommendations for Agronomic Crops in Minnesota, University of Minnesota Extension Service, BU-06240-S, 2001

**Table 10. Potash fertilizer recommendations for grasses and grass-legumes grown for hay and pasture**

Expected Yield	Potassium (K) Soil Test (ppm)				
	0—40	41—80	81—120	121—160	161 +
ton/acre	K <sub>2</sub> O to apply (lbs./acre)				
<b>Grasses</b>					
2	90	60	30	0	0
3	100	70	40	10	0
4	110	80	50	20	0
4+	120	90	60	30	0
<b>Grass-legumes</b>					
2	95	65	40	15	0
3	140	100	60	20	0
4	185	135	80	25	0
5	230	165	100	35	0

Source: Fertilizer Recommendations for Agronomic Crops in Minnesota, University of Minnesota Extension Service, BU-06240-S, 2001

*Noxious weeds must be controlled according to Minnesota State law (primary noxious weeds) and county law (secondary noxious weeds). Listed are the primary noxious weeds in Minnesota; other states may have different lists.*

Perennials

- Poison ivy
- Leafy spurge
- Field bindweed
- Perennial sowthistle
- Canada thistle
- Purple loosestrife

Biennials

- Bull thistle
- Musk thistle
- Plumeless thistle

Annuals

- Hemp

grazing a pasture with low stocking density frequently leads to selective grazing. This can lead to increased weed and brush problems. Continuous grazing at high stocking rates will often weaken desirable species. This can lead to rapid weed invasion.

Producers who have successfully implemented rotational grazing management often find that their pasture weed problems begin to diminish within the first few years of grazing. This is primarily because of the improved vigor and

competitiveness of desirable species and regular grazing of weeds in their more palatable, immature growth stage.

Grazing management alone, however, will not normally correct serious preexisting weed problems without great losses in animal performance. Thistles, brush, and poisonous plants may continue to be a problem even after you have intensified your grazing system. This is because even at high stocking rates cattle seldom eat these weeds.

Sheep or goats can offer an alternative weed control method. They often will consume plants that other animals avoid. As a result, there are opportunities for sheep and goats to be used as an environmentally friendly and cost effective way to control weeds. This method of control is especially practical when the weeds are located in areas where other control means are impractical.

### **What are the cultural and mechanical brush and weed control alternatives for pastures?**

#### ***A. Cultural Control:***

Several cultural practices help maintain a weed-free pasture. Weeds are generally more of a problem in overgrazed pastures than in fertile, well-managed pastures. Good grazing management (which includes pasture rest periods) and good fertility will go a long way in keeping the desirable forage species healthy and able to compete with pasture weeds. To prevent the spread of weeds, avoid spreading manure contaminated with weed seeds, clean equipment after working in weed-infested pastures, and

keep fence rows free of problem weeds.

#### ***B. Mechanical Control:***

Mechanical weed management involves the physical removal of all or part of the weeds and brush. Repeated mowing, clipping and hand weeding can diminish weed infestations. When in the bud to early bloom stage, cut weeds 3 to 4 inches above the soil. Mechanical weed control is more successful when coupled with good fertilization and grazing management.

Biennial and perennial weeds tend to be the most troublesome in established pastures. Biennials, such as musk and plumeless thistle, reproduce only by seed. They require a two-year period to produce seed. Clip annual and biennial weeds to prevent seed production.

Perennial weeds, such as Canada thistle and absinth wormwood, reproduce by seed, but also spread by vegetative parts such as underground roots or rhizomes. Clip perennial broadleaf weeds at the bud to flowering stages to maximize depletion of root carbohydrates. Repeated clipping of perennial broadleaf weeds with upright growth habits at 4-week intervals will eventually kill an infestation over a 2 to 3 year period, but may not be practical. Many perennials that persist in hay fields are adapted to the cutting schedules and growth habit of forages such as alfalfa. Other than hemp, annual weeds should not persist beyond the establishment year, unless soil disturbance such as overgrazing exposes soil.

Other options include tillage and burning. Tillage can be used to suppress weeds as part of a pasture renovation program, but is seldom used to manage weeds in a good pasture. Periodic burning may be a beneficial weed suppression tool and can be used in combination with mowing on woody plant species. Burning should be used as the first treatment and mowing used for the subsequent years.

### **When is control of brush and problem weeds with herbicides the best option?**

Even with the best cultural and mechanical methods of control, serious weed problems may need to be controlled with herbicides. The use of herbicides is justified when used with proper grazing management and where herbicide use results in desirable economic returns. Frequently, weeds are patchy, making spot spraying the preferred method of control. Spot spraying is less costly than broadcast applications. Correct identification of problem weeds is critical for successful control with herbicides. Consideration should be given to impacts on surface and groundwater, plant communities and wildlife habitat before herbicides are used. Always read and follow labels when selecting and using herbicides.

A variety of herbicide options exist for broadleaf weed control in grass pastures. No herbicides are labeled to selectively remove broadleaf weeds from legume-grass pastures without severe legume injury. Likewise, no herbicides are labeled to selectively remove unwanted grasses from cool-season grass pastures.

To control biennials such as musk thistle in pastures, apply herbicides in the spring or fall to the rosettes. This results in better control than herbicides applied after the flower stalk elongates. Perennial weeds are typically best controlled with herbicides after the early bud to flowering stage of growth. Fall herbicide applications usually provide the best control of biennial or perennial weeds. Fall applications of herbicide also control any seedlings that may have emerged. In established hay, most herbicides are applied to dormant forages or between cuttings to avoid excessive injury.

## ***Sacrificial Paddock Management***

### **How will the livestock be managed during times of drought or wet conditions?**

At some point in time, very wet weather or very dry weather will dominate a significant part of the growing season. Long periods of wet weather can be detrimental if the soil is so wet that livestock traffic causes damage to the roots and growth buds of the forages. Livestock traffic on wet soils can also destroy soil structure, cause compaction, reduce the ability of

the soil to absorb rainfall, and reduce the exchange of air between the soil and the atmosphere. Livestock travel in wet lanes can cause the lanes to become muddy, rutted, and easily eroded.

Extended dry weather will reduce the ability of the forage to produce new growth, reducing pasture yield. Paddocks may not have an adequate rest period to replenish the forage to a point where livestock can be allowed to graze them. The tendency of producers is to allow the livestock to continue the rotations, leading to an overgrazed situation. This will have a detrimental effect on forage production in the future.

In both situations (very wet or very dry) it is best to remove livestock from the pasture into a feedlot. Grazing can resume when forage and soil conditions permit.

Another method is to retain the livestock in one paddock or a portion of one paddock and provide some type of emergency feed, such as hay, until weather conditions improve. This is referred to as a sacrificial paddock. It is better to have a serious negative impact on a small area of the pasture system than to continue moving livestock through the paddocks, grazing the forages below the minimum stubble heights which will cause long-term yield reduction.

The area used as a sacrificial paddock should be one where the soils have good resistance to traffic, erosion potential is slight,

there is easy access to provide feed, and rejuvenation is relatively easy.

### **Will sacrificial paddocks be rejuvenated after removal of livestock?**

When livestock are placed back into a regular rotation, the sacrificial paddock will likely be in poor condition. The vegetation will most likely be gone or in very poor condition and the area may be in a rough and rutted condition. There are two options to consider:

1. The sacrificial paddock can be left to regenerate on its own. This may be successful if the livestock did not cause significant damage to the soil. The forages that were on the site prior to its use as a sacrificial paddock may resume growth after an extended rest period. The primary risk involved is that undesirable vegetation, such as weeds, will become the predominant vegetation on the site.
2. Another option is to prepare the site with tillage equipment and reseed it to desirable forage species. This may be the best option if the sacrificial paddock has been in use for a relatively long period of time.

*See University of Minnesota bulletin AG-BU-3157, Cultural and Chemical Weed Control in Field Crops*



# Grazing System Monitoring

## Pasture Record Keeping

### How do I know I have enough forage available?

There are various ways to determine available forage. One of the most useful is the Reserve Herd Days (RHD) concept. This method is a powerful tool because it is quick, easy, sufficiently accurate, and provides meaningful information to producers. The term Reserve Herd Days expresses the number of days of grazing remaining when considering the amount of forage currently on hand in the pasture system. Using this concept will provide the following:

- A determination of how much forage is on hand at the present time, expressed as a number of days of grazing currently available for your herd.
- A determination of where the forage is (which paddocks).
- A measurement of the ebb and flow of forage available over time.
- An indication of pasture condition and the trend in the condition.
- A guide to decision making when excesses and shortages of forages are apparent.

There are two commonly used methods of making RHD determinations, visual and calculated.

#### A. Visual Method:

This method requires a producer to go into the pasture and make an estimate of the number of days the herd will be able to graze each paddock. This estimate is based upon a visual determination of the quantity of forage available and how many days it will take the herd to graze the forage to the allowable stubble height.

The information is recorded so that comparisons can be made from week to week and from year to year. A blank form is available in Appendix F.

#### B. Calculated Method:

This method is a little more involved than the visual method, but it provides a more accurate estimate. The small amount of extra time required is worth the benefit of having more information on hand with which to make comparisons.

The following information is required to determine RHD with this method:

- The acres within each paddock.
- The estimated pounds of dry matter per inch of height per acre for the forages within each paddock. This

information is available from Table 6.

- The estimated pounds of dry matter the herd will utilize per day. This is simply the total weight of the herd multiplied by the utilization rate (0.04).

A blank form is available in Appendix G. Completion of this form requires going into each paddock, measuring the height of the forage, and placing the information in the correct spot on the form. The inches of forage available is the amount of the forage above the minimum stubble height.

The total pounds of available forage divided by the pounds of forage required each day by the herd (Daily Allocation) equals the Reserve Herd Days. If this number is small you may run out of forage soon. If the RHD is large there may be adequate forage available to harvest some as hay. Other options exist, but consideration must be made for the period of the grazing season when the determination is made, the current weather conditions, and possible changes in the size or makeup of the herd, as well as your management objectives. Having this information recorded is important for making comparisons throughout the grazing season, as well as from season to season.

## Is the productivity of the pasture increasing?

Forages that are in good condition will produce more feed than forages that are in poor condition. The worksheet **Determining Grassland Condition/Trend** (Appendix C) is a useful tool for assessing changes in the condition of the overall pasture. Condition of the forages is a significant factor considered in the completion of the form. An initial determination followed by annual monitoring will provide insight into the overall productivity changes. This evaluation should be done in the same area of the pasture and at the same time of the year each time to make the results meaningful.

Clipping and weighing pasture areas each year at the same location and same time of the year will provide useful information to determine the trend of productivity for a pasture. Instructions for this procedure are found in “Pastures for Profit” (see References section).

Another method of determining if the productivity is increasing is to weigh livestock at the beginning and end of each grazing season. This assumes that livestock will produce more if offered more forage to consume. This system of monitoring should be used with caution, since many variables can affect the end of season weights, such as parasite infection in the livestock, genetic changes in the herd, calving dates, or even the weather conditions.

Records should be kept to document the number of animal grazing days on each paddock. This provides information regarding how many head of livestock can be supported by a pasture system. The records are basically a record of: a.) day the animals were turned into a paddock, b.) day they were removed, c.) number of animals and their weight, d.) kind and class of livestock, e.) height of the forage when grazing was initiated and f.) height of the forage when the grazing was terminated.

## Are the natural resources improving?

The condition of the soil, forages, watercourses, and bird populations within a pasture system provides insight into the effectiveness of the grazing management. Actions that benefit these resources will likely have a positive effect on the production of forages.

It is important to record the results of tests or observations made so that meaningful comparisons can be made over time.

### A. Soils:

Soils are in good condition when they allow easy infiltration of rainfall, allow easy exchange of air with the atmosphere, and support a wide range of life-forms (bacteria, fungi, earthworms, etc.). In addition, organic matter content is a good indicator of the health of the soil.

### B. Watercourses:

Well-managed grazing will lead to improvements to watercourses within the pasture system. Features such as erosion in the bottoms and sides of channels should be noted, as well as the condition of the existing vegetation. Monitoring the condition of the watercourses in future years will indicate changes needed in the management of the grazing system.

### C. Forages:

Refer to the form **Determining Grassland Condition/Trend**, discussed earlier (Appendix C). This form is very good for monitoring forage condition. This considers such aspects as the species composition of the pasture (desirable vs. undesirable), plant density, and plant vigor.

### D. Bird Populations:

Birds are excellent “barometers” of the environmental condition of your pastures and your farm. Their populations react quickly to changes in conditions that affect their food sources and nesting habitat. In general, the more diverse the species and the higher the counts within each species, the healthier the environment on your farm. Select points within the pasture to use to do periodic bird counts, and then plan to do bird counts three times per year at each site.

# Grazing Plan Example

This section presents an example of a grazing plan. It represents a starting point for a rotational grazing system. Seven elements of the plan are illustrated:

- Sensitive Areas
- Livestock Summary
- Fencing System
- Livestock Watering System
- Heavy Use Area Protection
- Forages
- Grazing System Management

This plan is based upon the information gathered in the inventory phase of plan development.

## *Sensitive Areas*

The following sensitive areas are identified in this grazing unit (Diagram 6):

- a.) The stream flowing through the pasture is a sensitive area because uncontrolled access to this area by the livestock will

cause streambank erosion as well as degrade water quality. Manage these resources by breaking the pasture into smaller paddocks and reducing the amount of time the livestock have access to any segment of the stream.

Currently the streambanks are in poor condition in some locations. This is due to the livestock traveling to the stream to get water. Reduce the impact of the herd on the stream by subdividing the pasture, rotating the grazing, and providing alternative drinking facilities for the livestock. With the planned subdivision of the pasture, the livestock will have access to the stream from only three paddocks.

- b.) The flood-prone area can easily be damaged by livestock traffic during periods of wet weather or shortly after flooded conditions. Proper monitoring of the grazing system will avoid damage to this area.

- c.) The steep slope (Diagram 6), which is also drought prone, is a sensitive area because it is easily damaged by over-utilization and livestock traffic. This area can be managed closely by subdividing the pasture into paddocks, rotating the grazing, and monitoring the condition of the forage and soil to prevent damage.

## *Livestock Summary*

Currently there are 25 cow/calf pairs using the pasture. This plan considers increasing the size of the herd to 35 cow/calf pairs. The average weight of the cows is 1200 pounds. These animals are currently managed as one herd. In addition, a herd bull with an average weight of 2000 pounds, will be used.

Monthly and season-long forage requirements are estimated on the **Livestock Forage Monthly Balance Sheet** (Table 11). This indicates that there will be a surplus of forage on a season-long basis. The monthly balance indicates that there will be adequate to surplus quantities of forage through July, and a very small shortage of forage in August. A rather large deficiency occurs during the months of September and

**Diagram 6. Pasture Inventory Map**

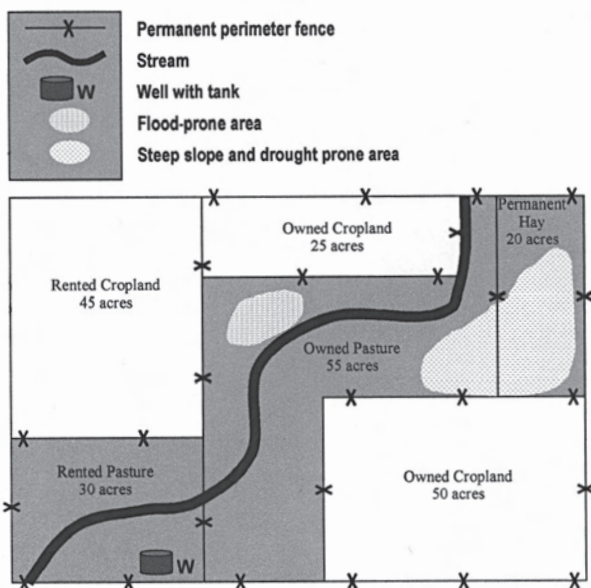

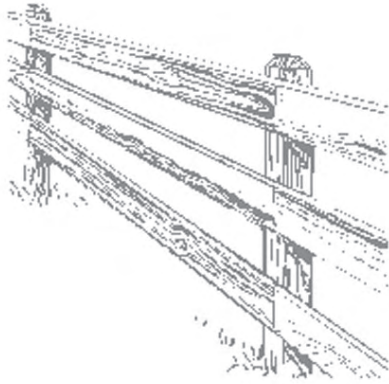

October. The forage balance indicates that some of the pasture may be harvested for hay in the spring, and this will be done when weather conditions appear to be favorable to forage regrowth. This will provide feed for the months of September and October. Refer to the **Grazing System Management** portion of this plan for information related to grass management and sacrificial paddocks to be used during this time period.

## Fencing System

Perimeter fences are already in place and are in adequate condition. Interior fences will be constructed to subdivide the pasture into paddocks using 1 or 2 strands of high tensile wire. Locations of the fences are shown on the Grazing Plan Map (Diagram 7).

The installation of the interior fences will break the pasture unit into ten paddocks, ranging from 7-10 acres each. Approximately 13,000 feet of interior fence is required for this system. During periods of average growth, each paddock will be capable of approximately 2-4 days of grazing. In addition to subdividing the pasture, lanes will be constructed. The lanes will allow movement of the livestock from a paddock to any other without passing through a recently grazed paddock.

**Table 11. Livestock Forage Monthly Balance Sheet – Current Forage Summary**

Field	Kind of Forage	Forage Yield (lbs/acre)	Acres	Total Yield (lbs)	Forage Availability Per Month (lbs x 1000)					
					May	June	July	Aug	Sept	Oct
Rented	Red Clover/ Orchardgrass	4,500	30	135,000	33.8	54.0	27.0	13.5	6.8	0.0
Owned	Red Clover/ K. Bluegrass	3,500	38	133,000	33.3	53.2	26.6	13.3	6.7	0.0
Owned	Reed Canarygrass	3,500	17	59,500	11.9	17.9	14.9	6.0	6.0	3.0
Owned	S. Bromegrass/Alfalfa	4,500	20	49,500	for hay	for hay	31.5	18.0	0.0	0.0
<b>Total lbs. Forage Available (x 1000)</b>				377,000	79.0	125.1	100.0	50.8	19.5	3.0
<b>Total lbs. Forage Required by Livestock (x 1000)</b>				312,000	50.4	50.4	52.8	52.8	52.8	52.8
<b>Total lbs. Forage Excess or Deficiency (x 1000)</b>				65,000	28.6	74.7	47.2	-2.0	-33.3	-49.8

**Table 12. Livestock Forage Monthly Balance Sheet – Current Livestock Summary**

Kind/Class Livestock	Number of Animals	Average Weight	Monthly Utilization	Forage Requirements Per Month (lbs x 1000)					
				May	June	July	Aug	Sept	Oct
Beef cow/calf	35	1200	1.2	50.4	50.4	50.4	50.4	50.4	50.4
Herd bull	1	2000	1.2			2.4	2.4	2.4	2.4
<b>Totals</b>	36			50.4	50.4	52.8	52.8	52.8	52.8

\*0.04 daily utilization rate (includes forage waste) x 30 days/month.

## Livestock Watering System

Water will be delivered from the well through a high-density plastic hose system laid on top of the ground (Diagram 8). Portable tanks will be used as drinking facilities. They will be moved with the herd as they graze through the pasture system. Approximately 6,400 feet of pipeline is required, along with two portable tanks. Refer to Diagram 8 for locations of the water pipelines.

The pipelines and tanks do not require frost protection, since they will be drained every fall prior to freezing. The stream will provide water for the livestock in the event that the well of pipeline should fail.

## Heavy use Area Protection

Where the lanes cross the stream, the stream banks and channel will be shaped and stream crossings will be installed using heavy use area protection measures. Because the water tanks are portable they do not require heavy use area protection.

## Forages

The existing forages in these pastures are:

Paddocks 7, 8, 9, 10:

Orchardgrass

Paddocks 5, 6:

Reed Canarygrass

Paddocks 1, 2, 3, 4:

Kentucky Bluegrass

The current condition of the forages is poor. To improve the pastures all paddocks, except for the area of reed canarygrass, will be frost seeded with clover to provide nitrogen for increased yield and to improve the nutritional value of the forage mix.

To provide better quality and quantity of forages during the midsummer slump that cool season grasses go through, the alfalfa/bromegrass hay field will be utilized after one crop of hay has been harvested.

Yields are estimated on Table 11. These are only estimates based upon expected yields with the planned improvements in place. Actual yields should be determined when the rotational grazing system is in place. The grazing system will require monitoring to maximize forage utilization without overgrazing.

Diagram 7. Fence Location Map

Diagram 7. Fence Location Map

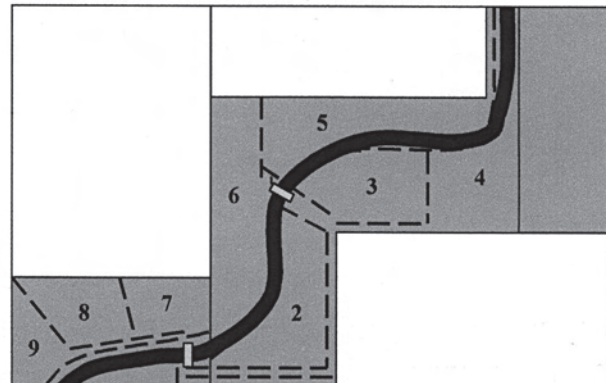
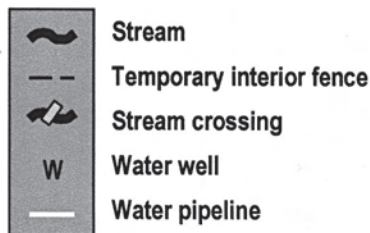
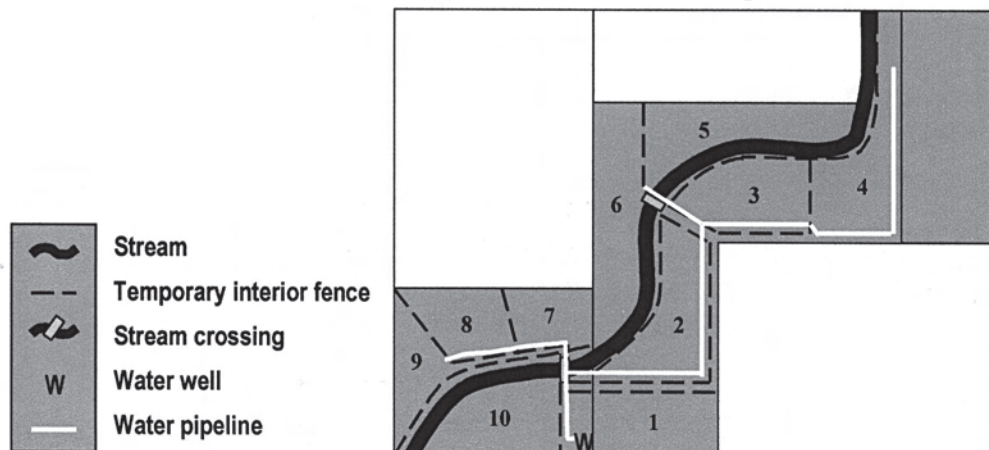

Diagram 8. Water Location Map

Diagram 8. Water Location Map



## ***Grazing System Management***

The key to maintaining vigorous vegetation is to avoid overgrazing. The forage plants will recover from grazing without depleting root reserves only if there is adequate leaf area remaining to meet the food requirements of the plant.

Initiate grazing in early spring when the orchardgrass is 3-4 inches tall, reed canarygrass is 4-5 inches tall, and the grass in the Kentucky bluegrass paddocks is 2 inches high. Because the grass growth in the spring is rapid, the livestock should be moved through the system from paddock to paddock at a fairly rapid pace, every 1-2 days if possible. As the grass growth slows later in the growing season, slow the rotation through the paddocks to an approximate interval of 4-6 days, basing movement of the livestock on:

- The minimum stubble heights of the forages:
  - 2 inches for Kentucky bluegrass
  - 3 inches for orchardgrass
  - 4 inches for reed canarygrass
- The minimum required regrowth:
  - 4 inches for Kentucky bluegrass
  - 6 inches for orchardgrass
  - 8 inches for reed canarygrass

The number of actual grazing days will vary with the size of the paddock, and in practice it will vary with the condition of the forage, how much grazing pressure has been applied in the past, weather conditions, and time during the grazing season.

The hay field will be used for grazing during the summer after a crop of hay has been harvested and regrowth is sufficient. This will provide high quality forage for mid- to late summer, and will allow an extended rest period for the other paddocks at a time of the season when they need it (35-50 days). The hay field will be subdivided by temporary fence into 3 paddocks to allow better management of the forages.

The balance of forage available and forage required indicates that there will be significant periods of time during September and October when the livestock will need to be placed into a sacrificial paddock in late summer and early fall and fed hay because there will not be adequate forages for grazing in the pastures. Plan on having hay on hand for this from the harvest of excess available in June and July.

Paddock 1 will be used as the sacrificial paddock when necessary. This paddock is less erodible than the others and does not contain sensitive areas. This paddock is easily accessible for emergency feeding.

During very wet weather, livestock traffic may cause excessive damage to the soil or the forage. If this occurs, move the livestock from paddock to paddock more rapidly, or confine the animals to the feedlot (or use a sacrificial paddock) and provide them with emergency feed. When conditions improve, put the livestock back into a regular rotation.

During very dry weather, the

forage growth will slow considerably. The livestock should be moved at a slower pace through the paddocks. If minimum stubble height cannot be maintained, confine the livestock to a portion of one of the paddocks (a sacrificial paddock) and provide them with emergency feed until they can be put back into a regular rotation. Do not use any of the sensitive areas as sacrificial paddocks.

Regrowth of the forage prior to fall freeze-up is important for maintaining health and vigor of the plants through the winter. Prior to a killing frost, the forage should have 6 inches of regrowth on the reed canarygrass and orchardgrass, and 4 inches on Kentucky bluegrass. Since these heights are not possible to attain on all paddocks, manage one third of the paddocks so that they get the required regrowth each year, and then alternate this treatment from one year to the next. This regrowth can be grazed to the minimum stubble heights as stockpiled forage after the forages go dormant, about mid-October.

Fertilization of the pastures will be done to ensure optimum yields. Fertilizer applications will be based on soil tests and economic analysis. The pH of the soil will be maintained between 6.0 to 7.0.

Overwintering will not be done on this pasture system. Each paddock will be clipped as the livestock are rotated out if needed to control weeds.

“Grazing Management, Pasture

# References

Fertility, Weed Control and Species Selection for Productive Pastures.” 1998. Greg Cuomo. *In Proc.* 1998 “Grazing Management, Pasture Fertility, Weed Control and Species Selection for Productive Pastures.” 1998. Greg Cuomo. *In Proc.* 1998 Minnesota Beef Cow/Calf Report. P. 23-28.

Minnesota Beef Cow/Calf Report. P. 23-28.

“Improve Your Pasture in Five Easy Steps.” T. Hovde, B. Stommes, L. Williams, L. Zilliox, J. Siira. University of Minnesota Extension Service and Minnesota Department of Agriculture.

“Pastures for Profit: A Guide to Rotational Grazing.” 2002. University of Wisconsin (A3529) and University of Minnesota Extension Service publication FO-06145.

“Pasture Management Guide for Livestock Producers.” 1998. Iowa State University Extension publication Pm-1713.

“Alfalfa Management Guide.” 2002. North Central Regional Extension Publication #NCR547.

“Fertilizer Recommendations for Agronomic Crops in Minnesota.” 2001. University of Minnesota Extension Service publication BU-06240-S.

“Impact of Grazing Cattle on Distribution of Soil Minerals.” 1986. James Gerrish, James Brown, and Paul Peterson. *In Proc.* 1995 National Forage & Grassland Council.

“Pasture Weed Control.” 1997. Roger Becker and Greg Cuomo. *In Proc.* Minnesota Lamb and Wool Producers Annual Meeting, St. Cloud, MN.

“Forage Legumes: Clovers, Birdsfoot Trefoil, Cicer Milkvetch, Crownvetch, Sainfoin and Alfalfa.” 1993. University of Minnesota Extension Service, SB-5963-F.

“Identifying Pasture Grasses.” 1996. University of Wisconsin-Extension A3637.

“Using All-weather Geotextiles for Lanes and Paths.” 1999. Kevin Janni, Brian Holmes, and Ted Funk. Midwest Plan Service publication AED-45.

“Stockman’s Guide to Range Livestock Watering from Surface Water Sources.” Prairie Agricultural Machinery Institute: Manitoba, Canada.

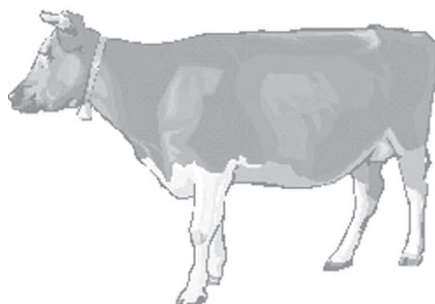

## Appendix A. Livestock Forage Monthly Balance Sheet

**Producer:** \_\_\_\_\_ **Location:** \_\_\_\_\_ **Date:** \_\_\_\_\_

LIVESTOCK SUMMARY				Forage Requirements Per Month (lbs. x 1000)						
Kind/Class Livestock	Number of Animals	Average Weight		Apr	May	June	July	Aug	Sept	Oct
			1.2*							
			1.2*							
			1.2*							
			1.2*							
			1.2*							
			1.2*							
<b>Totals</b>										

\*0.04 Daily utilization rate (2.5% intake, 0.5% trampling loss, and 1% buffer) x 30 days/month

FORAGE SUMMARY					Forage Requirements Per Month (lbs. x 1000)						
Field	Kind of Forage	Yield/ Acre	Acres	Total Yield	Apr	May	June	July	Aug	Sept	Oct
Total lbs., Produced from Forage (x 1000)											
Total lbs., Required for Livestock (x 1000)											
Total lbs., Excess or Deficiency (x 1000)											



# Appendix B1. Identification Key for Common Forage Species – Grass

## Cool-Season Forage Grass Identification Key

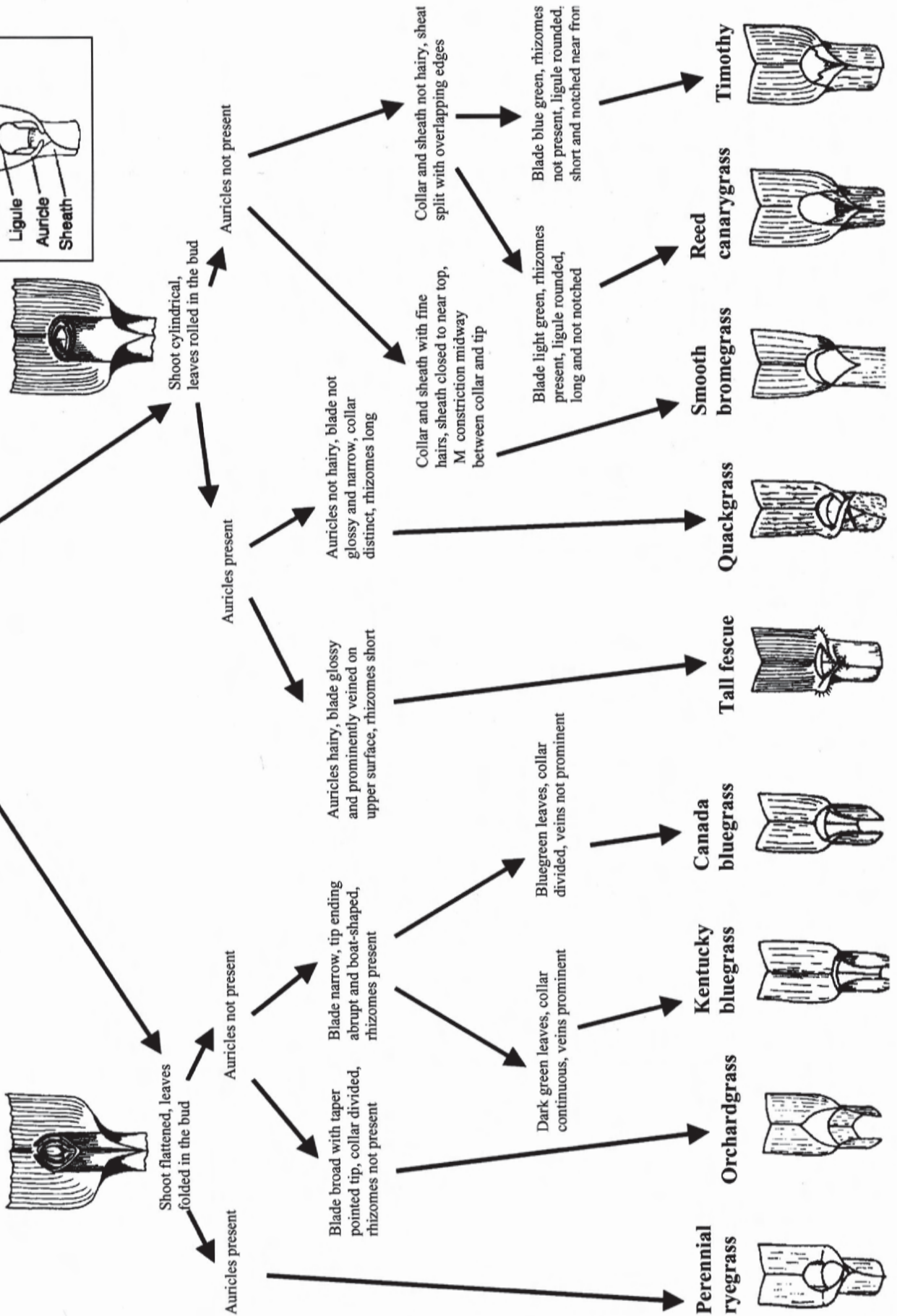
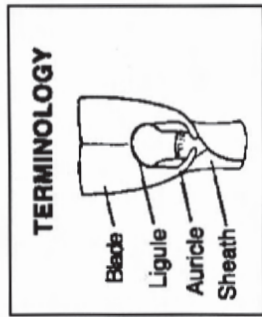

# Appendix B2. Identification Key for Common Forage Species – Forage

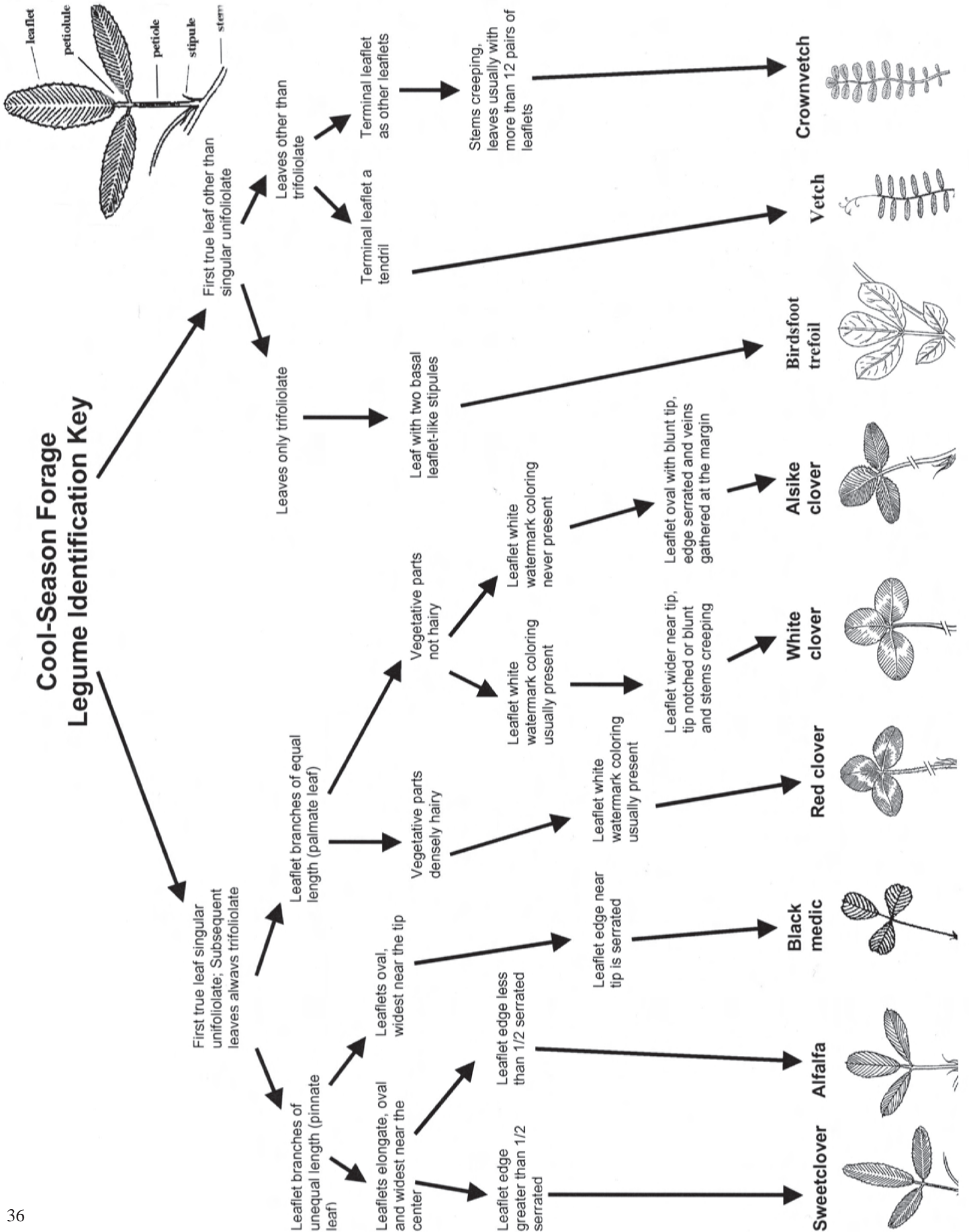

# C1. Determining Grassland Condition/Trend

Producer: \_\_\_\_\_  
 County: \_\_\_\_\_  
 Tract #: \_\_\_\_\_

Date: \_\_\_\_\_  
 Recorded By: \_\_\_\_\_

		Field #					
		Acres					
		Month & Year	M __ Y __	M __ Y __	M __ Y __	M __ Y __	M __ Y __
Category	Score	Value	Value	Value	Value	Value	Value
1) Species Composition	Undesirable      Desirable 0 1 2 3 4						
2) Plant Diversity	Narrow              Broad 0 1 2 3 4						
3) Plant Density	Sparse              Dense 0 1 2 3 4						
4) Plant Vigor	Weak              Strong 0 1 2 3 4						
5) Legumes in Stand	Less than 10%      More than 40% 0 1 2 3 4						
6) Plant Residue	Deficient    Appropriate    Excess 0 2 4 2 0						
7) Uniformity of Use	Spotty    Intermediate    Uniform 0 1 2 3 4						
8) Severity of Use	Heavy      Moderate      Light 0 2 4 2 0						
9) Woody Canopy	More than 40%      Less than 10% 0 1 2 3 4						
10) Soil Erosion	Severe      Moderate      Slight 0 1 2 3 4						

## Appendix C2. Inventory Category Items

- 1) **Species Composition** - Visually estimate the % composition by weight of each group of plants and assign a value. The categories desirable, intermediate, and undesirable refer to the preferred use of the plants by the grazing animal, and intended use of the grazing land. The score ranges from “0”, with no or few desirable or intermediate plant species, to “4”, which represents mostly desirable or intermediate plant species present.
- 2) **Plant Diversity** - Evaluate the number of different species of plants that are well represented on the site. If only one species of plant occurs, diversity is narrow; if eight or more species of plants are present, diversity is broad. If 4-5 plant species are present, the score would be in the middle of this range.
- 3) **Plant Density** - Ignore plants classified as undesirable. Visually estimate the density of living desirable and intermediate plant species that would be present at a 2-inch stubble height. Ask yourself if there is room for more desirable plants? Scores range from Dense (>95%), Medium (75-85%), Sparse (<65%).
- 4) **Plant Vigor** - Evaluate the health and productivity of the desirable and intermediate plant species. Look for evidence of plant color; leaf area index; plant reproduction; presence of disease or insects; rate of growth and re-growth, etc. Area plants growing at their potential?
- 5) **Legumes in Stand** - Visually estimate the % composition by weight of the legumes present in the stand on the area being evaluated. 0 = <10%, 1 = 10-19%, 2 = 20-29%, 3 = 30-39%, and 4 = >40%.
- 6) **Plant Residue** - Evaluate the dead and decaying plant residue on the soil surface. Excessive levels of residue inhibit plant growth and vigor. Appropriate levels of residue do not inhibit plant growth but help retard runoff, reduce soil erosion, improve water intake, recycle nutrients to the soil surface, and provide a favorable microclimate for biological activity. Deficient residue levels result in bare or near bare ground beneath the growing plants.
- 7) **Uniformity of Use** - Evaluate how well the animals are grazing all plants to a moderate uniform height throughout the field. Spotty grazing appears as uneven plant heights, with some plants or parts of the field grazed heavily and other areas grazed only slightly or not at all.
- 8) **Severity of Use** - Evaluate the severity of use by grazing animals based on plant stubble height in the field. For cool season grass species and legumes a stubble height of less than 2 inches would indicate heavy use; stubble height of 2-6 inches would indicate moderate use; and stubble height more than 6 inches would indicate light use. For warm season grasses increase the height in each category by 2 inches.
- 9) **Woody Canopy** - Estimate the percent canopy (area shaded at noon) of woody plant cover over six feet tall. 0 = >40%, 1 = 30-39%, 2 = 20-29%, 3 = 10-19%, 4 = <10%.
- 10) **Soil Erosion** - Visually observe signs of any type of erosion and assign a severity rating for the field being evaluated.

## Appendix D1. Average Forage Yields for Northern Minnesota and Northern Wisconsin

-----% Availability by Month-----								
Species	Quality	Yield (lb/a DM)	May	June	July	Aug	Sept	Oct
<b>Cool Season Grasses</b>								
Kentucky Bluegrass	Good	4700	30	20	20	10	15	5
	Poor	1240	15	45	15	10	10	5
Orchardgrass	Good	5580	25	20	20	15	15	5
	Poor	1520	20	35	20	10	10	5
Reed Canarygrass	Good	5460	25	20	30	10	10	5
	Poor	1940	25	30	20	10	10	5
Smooth Bromegrass	Good	4900	35	20	20	10	10	5
	Poor	1780	30	30	15	10	10	5
Tall Fescue	Good	6000	15	25	20	15	15	10
	Poor	1740	20	45	15	5	10	5
Timothy	Good	4800	25	30	15	10	15	5
	Poor	1600	15	50	10	10	10	5
<b>Warm Season Grasses</b>								
Big Bluestem	Good	3500	0	0	25	50	25	0
	Poor	2520	0	0	30	45	25	0
Switchgrass	Good	4830	0	0	35	50	15	0
	Poor	2170	0	0	30	45	25	0
Sudangrass	Good	5500	0	0	20	30	30	20
	Poor	3000	0	0	40	45	15	0
<b>Legumes</b>								
Alfalfa/grass	Good	5540	20	30	30	20	0	0
	Poor	3000	20	30	30	20	0	0
Birdfoot Trefoil	Good	4320	10	40	35	15	0	0
	Poor	2500	10	40	35	15	0	0
Red Clover/grass	Good	5500	20	30	30	20	0	0
	Poor	2750	20	30	30	20	0	0
<b>Alternative Forages</b>								
Oat	Good	2500	55	35	10	0	0	0
	Poor	1600	60	40	0	0	0	0
Oat + Rape	Good	2410	30	45	25	0	0	0
	Poor	1600	30	45	25	0	0	0
Winter Rye	Good	2300	55	25	0	0	5	15
	Poor	1200	65	25	0	0	5	5

Source: Pastures for Profit: A Guide to Rotational Grazing, University of Minnesota, AG-FO-06145

Good Condition = lime, P, K and split N application plus rotational grazing management

Poor Condition = no fertilizer added plus continuous grazing management

## Appendix D2. Average Forage Yields for Southern Minnesota and Southern Wisconsin

-----% Availability by Month-----								
Species	Quality (lb/a DM)	Yield	May	June	July	Aug	Sept	Oct
<b>Cool Season Grasses</b>								
Kentucky Bluegrass	Good	5680	30	30	10	10	15	5
	Poor	1900	10	40	10	15	15	10
Orchardgrass	Good	6440	20	35	15	10	15	5
	Poor	2260	10	30	10	20	20	10
Reed Canarygrass	Good	6180	20	30	25	10	10	5
	Poor	2720	20	30	20	10	15	5
Smooth Bromegrass	Good	6080	30	30	15	10	10	5
	Poor	2620	25	35	10	10	15	5
Tall Fescue	Good	7940	20	30	20	10	15	5
	Poor	2740	15	40	10	10	15	10
Timothy	Good	6260	25	35	10	10	15	5
	Poor	2340	10	45	10	15	15	5
<b>Warm Season Grasses</b>								
Big Bluestem	Good	5000	0	10	40	35	15	0
	Poor	2520	0	15	40	35	10	0
Switchgrass	Good	5000	0	15	35	35	15	0
	Poor	2500	0	15	45	35	5	0
Sudangrass	Good	5500	0	0	20	30	30	20
	Poor	3000	0	0	40	45	15	0
<b>Legumes</b>								
Alfalfa/grass	Good	5820	20	25	35	20	0	0
	Poor	3000	20	25	35	20	0	0
Birdsfoot Trefoil	Good	5120	10	50	30	10	0	0
	Poor	2500	10	50	30	10	0	0
Red Clover/grass	Good	5500	25	40	20	10	5	0
	Poor	2750	25	40	20	10	5	0
<b>Alternative forages (cool-season annual forages)</b>								
Oat	Good	3000	55	35	10	0	0	0
	Poor	1600	60	40	0	0	0	0
Winter rye	Good	2800	55	25	0	0	5	15
	Poor	1200	65	25	0	0	5	5
Winter wheat	Good	2800	55	25	0	0	5	15
	Poor	1200	60	30	0	0	5	5

Source: Pastures for Profit: A Guide to Rotational Grazing, University of Minnesota, AG-FO-06145

'Good condition = lime, P, K and split N application plus rotational grazing management;

Poor condition = no fertilizer added plus continuous grazing management

## Appendix E. Water Systems Design Considerations

### ***A. Ramps to Surface Water:***

Restricted access points consist of ramps which direct livestock to drink from limited areas of a lake, pond, or stream. During fence construction, a hard surface is installed to keep the livestock confined to the access point.

Advantages:

- Livestock will not have free access to open water sources except at controlled points, helping to reduce water quality problems.
- Capacity is not an issue, unless the water source is unreliable.
- No power required.

Disadvantages:

- High cost of construction and maintenance.
- Livestock still have access to open sources of water.
- Lack of portability; livestock need to travel to the source of water to get a drink.

### ***B. Livestock Powered Pumps:***

Livestock powered pumps (nose pumps) utilize a diaphragm pump which is lever-activated by the nose of the animal as they drink water from a cup cast into the unit.

Advantages:

- Simple and economical, costing half as much as a typical restricted access point.
- Easily moved from one water source to another and from paddock to paddock.
- No water storage required.
- No power required.

Disadvantages:

- Animals must be trained to use pumps.
- Smaller animals, such as calves may not have the strength to use them.
- Sheep will not use a nose pump.
- Generally can pump for distances less than 300 feet.
- Generally cannot lift water more than 30 feet.
- Must be anchored to something solid or a heavy base.

### ***C. Solar Powered Pumps:***

Solar panels are used to power direct current electric motors, usually 12 or 24 volt. The pumps can run continuously or the energy can be stored in a battery for use upon demand.

Advantages:

- Can operate in remote locations, no outside power required.
- Low maintenance.
- Can pump water for long distances.
- Variety of pumps and panels allows customization for your site.

Disadvantages:

- Expensive (\$1500-6000).
- Must store water. A three-day reserve is recommended.
- Not easily portable.

#### ***D. Sling Pumps:***

Sling pumps operate by the action of flowing water. The entire body of the sling pump rotates due to a propeller. Inside the pump body is a coiled, open-ended tube. This tube alternately picks up water and air, and forces the water out through an outlet hose. The water is normally stored in a tank and later distributed to the livestock. A wind-powered version is available for use on ponds.

##### Advantages:

- Can operate in remote locations without an outside power source.
- Low maintenance.
- Can pump for distances, just over 1 mile.
- Can lift water up to 80 feet.
- Low cost (\$550-850).
- Portable; easily moved from one water source to another.

##### Disadvantages:

- Requires wind or water movement to operate.

#### ***E. Hydraulic Ram Pumps:***

Ram pumps require flowing water, or water under pressure through a drive pipe, to operate. A minimum of 3 feet of fall is required to operate a ram pump. Normally, water is pumped to a storage tank for further distribution to drinking facilities in paddocks.

##### Advantages:

- Economical to operate.
- No outside energy required, can operate in remote locations.
- Reliable, with few moving parts.
- Can lift water to a maximum of 250 feet.
- Can pump water for a relatively long distance.

##### Disadvantages:

- Adequate water flow required to operate the pump.
- Must be anchored to a solid base.
- Not portable.
- Must be protected from frost, or drained for the winter.
- Overflow water must be drained from the area in which the pump is installed.
- Cost range from \$350 for a small pump to \$7000 for a large pump.







## Grazing Plan Checklist

This list identifies the primary components of a grazing plan. Addressing each of these will result in a detailed plan for proper management of a forage-based livestock operation.

- Sensitive Areas
  - Sensitive Areas Identified and Described
  - Management Strategy for Protecting Sensitive Areas
- Livestock Summary
  - Livestock Kind and Class
  - Livestock Number and Average Weight by Herd
  - Forage Balance Sheet
- Fencing System
  - Kind of Fence Defined
  - Fence Locations Shown on Map
  - Length of Fence to be Constructed
- Livestock Watering System
  - Water Source Identified
  - Location of Pipelines Shown on Map
  - Locations of Permanently Placed Tanks Shown on Map
  - Length of Pipeline and Number of Tanks
  - Emergency Watering Plans Outlined
- Heavy Use Area Protection
  - Locations Shown on Map
- Forages
  - Forage Species Identified
  - Condition of Pastures Documented
  - Forage Production Estimates Made
  - Detailed Seeding Plans Prepared
- Grazing System Management
  - Guidance for Initiating and Terminating Grazing
  - Contingencies for Wet Weather and Drought Defined
  - Grazing Management Prior to Fall Freeze Addressed
  - Forage Deficiencies and Surpluses Addressed
  - Sacrificial Paddocks Identified
  - Rejuvenation of Sacrificial Paddocks Addressed
  - Livestock Over-wintering Areas Identified
  - Brush and Weed Control Addressed
  - Pasture Fertilization Addressed

Publication made possible by  
the following organizations:



- ☐ University of Minnesota Extension Service
- ☐ Natural Resources Conservation Service
- ☐ University of Minnesota Water Resource Center

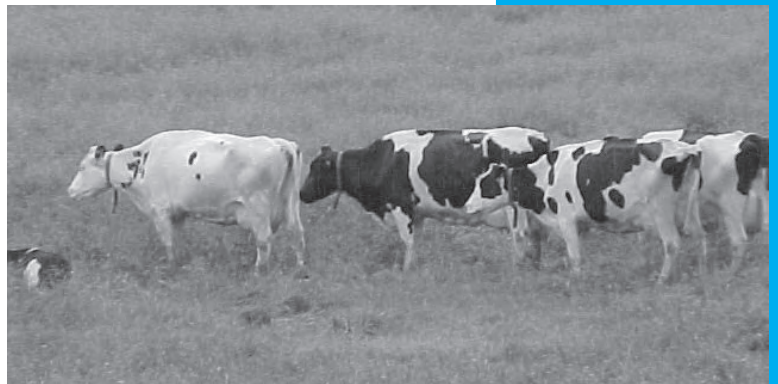

**BU - 07606 - S**  
**Revised 2003**

Find more University of Minnesota Extension Service educational information at [www.extension.umn.edu](http://www.extension.umn.edu)  
Additional copies of this item can be ordered from the University of Minnesota Extension Service Distribution Center,  
405 Coffey Hall, 1420 Eckles Avenue, St. Paul, MN 55108-6068, e-mail: [order@extension.umn.edu](mailto:order@extension.umn.edu) or credit card  
orders at (800) 876-8636. Copyright © 2003, Regents of the University of Minnesota. All rights reserved.



# Extending grazing and reducing stored feed needs

Don Ball  
Ed Ballard  
Mark Kennedy  
Garry Lacefield  
Dan Undersander





# CONTENTS

- WHY EXTEND THE GRAZING SEASON?** . . . . . 1
- EXPLOIT FORAGE GROWTH DISTRIBUTION DIFFERENCES** . . . . . 1
  - Grow warm-season and cool-season perennial grasses. . . . . 1
  - Use legume companion species . . . . . 2
  - Plant annuals to complement perennials . . . . . 2
  - Timely planting . . . . . 3
  - Variety selection . . . . . 3
- STOCKPILE FORAGE** . . . . . 3
  - Tall fescue . . . . . 4
  - Other forage crops . . . . . 4
  - Use stockpiled forage efficiently. . . . . 6
- TAKE ADVANTAGE OF UNIQUE GRAZING OPPORTUNITIES** . . . . . 6
  - Graze crop residues. . . . . 6
  - Graze dormant alfalfa . . . . . 7
  - Graze hayfields . . . . . 7
  - Use other plant growth . . . . . 8
- FORAGE OR LIVESTOCK MANAGEMENT APPROACHES** . . . . . 8
  - Grazing management . . . . . 8
  - Irrigation . . . . . 9
  - Fertilization and liming . . . . . 10
- OTHER USEFUL CONCEPTS** . . . . . 11
  - Match forage quality and nutrient intake to animal needs. . . . . 11
  - Change the stocking rate . . . . . 12
  - Use winter annuals in crop rotations or to supplement perennial forages . . . . . 12
  - Overseed winter annuals on summer grass sods . . . . . 14
  - Provide supplemental feed during warm weather . . . . . 15
  - Minimize hay losses . . . . . 15
- POSSIBLE PASTURE COMBINATIONS BY REGION** . . . . . 16

## Why extend the grazing season?

For most livestock producers, extending the grazing season for their animals, or otherwise filling gaps in pasture forage availability to reduce stored feed needs, should be a high priority objective. There are several reasons why this is beneficial:

- **Better for the environment.** Feeding hay or other stored materials in a barn or other enclosed area concentrates animals, and the manure that accumulates requires expense to remove. Feeding livestock in pastures often results in hoof damage to the land.
- **Weather is less of a concern.** Weather is a major concern with hay production, but animals can graze almost without regard to weather.
- **Higher-quality forage leads to better animal performance.** The forage quality of young, vegetative pasture growth and even leafy autumn residue is usually considerably higher than that of hay, which is produced by cutting older, more fibrous forage. Consequently, performance is typically better when animals graze properly managed pasture.

- **Requires less labor.** Less labor is required to have animals graze rather than to provide them with stored feed. In particular, in contrast to feeding stored feed in an enclosed facility, the labor associated with manure removal is avoided.
- **Lowers expenses.** Stored feed is almost always two to three times more expensive per animal or per day than pasture. In livestock budgets, stored feed typically accounts for 25% or more of the cost of production, and producer records often reveal it to be higher. The quantity of stored feed required is one of the best indicators of profitability for a livestock operation. In general, the less hay needed, the more cost-efficient the operation.

Clearly, extending the grazing season and reducing the need for stored feed is highly desirable. Though the best techniques to accomplish this vary with geographic region, type of farming operation, and other factors, this publication outlines strategies that can be used in some or many areas to extend grazing and reduce stored feed needs, thus increasing profit.

## Exploit forage growth distribution differences

### Grow warm-season and cool-season perennial grasses

Most grazing programs are based around perennial forage species, mainly grasses. In the northern United States, most perennial forages are cool-season species that make most of their growth in spring and autumn. In the South, warm-season perennials that make most of their growth during warm weather are most common. Even among species within these categories, the specific dates during which pasture forage will be available for grazing, as well as the total grazing days per year, can vary considerably.

When making planting decisions regarding forage crops, it is always important to take soils, sites, and climatic conditions into consideration and to only plant species that are known to be adapted. For example, warm-season perennial options are limited in the most northerly states, and cool-season perennial

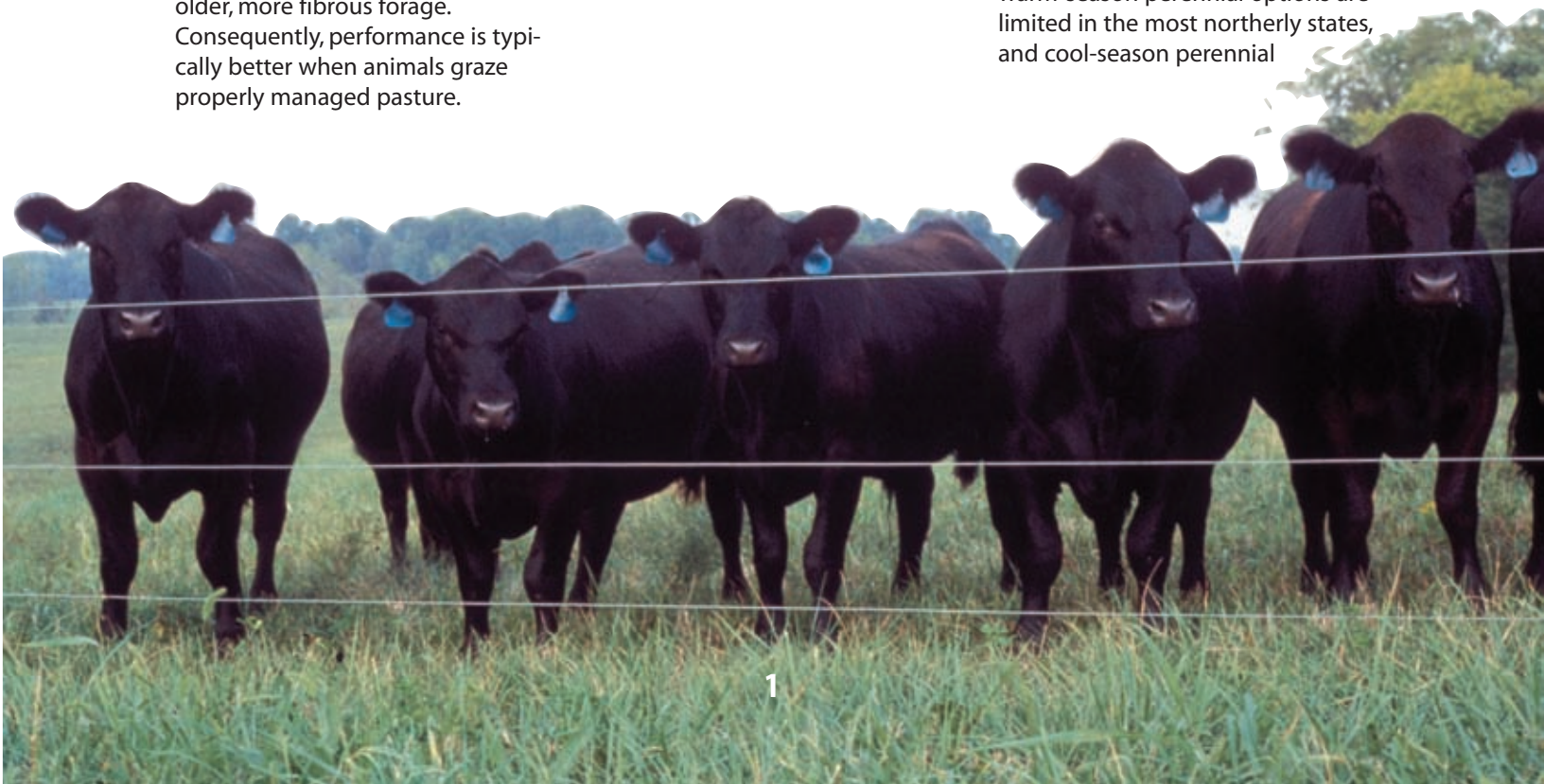

options are limited in the Deep South. However, in many areas of the nation there is an opportunity to have at least some pasture acreage of warm-season perennials and cool-season perennials.

For example, in the area between the upper Midwest/Northeast and the Deep South, tall fescue, orchardgrass, and white clover are some of the more widely grown cool-season perennial forages. However, several warm-season perennials can be grown as well, including some varieties of bermudagrass, various native grasses, and (especially in the western portion of this area) weeping lovegrass.

Usually it is best to plant warm-season and cool-season perennials in different fields, but in some areas they may volunteer as mixed stands, or can sometimes be successfully planted and maintained together. However, mixed stands of cool-season and warm-season species require more careful management; otherwise, the stand of the less-favored species may decline over time. Where mixtures can be grown, the result is a longer grazing season, a more constant supply of forage through the season, and usually greater total dry matter production than either would produce alone.



In some instances or locations, growth distribution can differ significantly between species within the warm-season and cool-season perennial categories. For example, within warm-season perennial grasses, switchgrass, dallisgrass, and bahiagrass begin growth earlier in spring than bermudagrass. Within cool-season perennial grasses, tall fescue makes more autumn growth than orchardgrass in the southern portion of its area of adaptation within the USA, though not in the Upper Midwest. Therefore, as the number of different forage grasses grown on a farm increases, the length of the grazing season also often increases.

## Use legume companion species

Some producers regularly face a forage deficit in summer, most commonly because they live in areas in which cool-season perennial grasses dominate pastures. Growing a cool-season perennial legume as a companion species to these grasses can help even out forage production. Red clover is a good example, as it often makes an impressive amount of growth during warm weather. Alfalfa, with its deep taproot, has an even longer growing season, and in many

**Growing perennial legumes with perennial grasses offers numerous benefits including often extending the grazing period.**

areas is a dependable producer of high-quality forage even during dry weather. Before seeding legumes, the pasture needs to be fertilized and limed according to soil test recommendations, and grasses must be grazed closely or otherwise suppressed just before planting.

## Plant annuals to complement perennials

The cost per unit of dry matter produced is usually higher with annual forages than with perennial forages. However, annuals may produce higher quality forage and often complement perennials by producing forage when the perennials are dormant or growing slowly.

Warm-season annual grasses such as sudangrass, sorghum-sudangrass hybrids, and pearl millet can complement cool-season perennial forages and offer the advantage of producing a lot of forage quickly, but grazing management of these species can be challenging. These upright-growing forages should be planted separate from cool-season perennials to prevent excessive shading. They perform best when planted on a prepared seedbed, although establishment costs are higher and the potential for soil erosion is also greater when using this approach.

Crabgrass is another warm-season annual that is vigorous and widely adapted, but it is sometimes overlooked as a forage crop. Yield of crabgrass is usually less than that of the summer annual grasses mentioned in the previous paragraph, but forage quality (and therefore animal performance) is quite good by comparison. Where some tillage can be provided sometime between autumn and spring, it is usually not difficult to get crabgrass to reseed and to provide relatively inexpensive volunteer stands year after year.



Striate lespedeza and Korean lespedeza are warm-season annual legumes that work well in some situations in the Upper South. Both species typically produce relatively low yields, but are adapted on dry, acid, upland sites where clovers do not persist well. Furthermore, they produce good-quality forage during summer when the quality and quantity of forage provided by cool-season perennials such as tall fescue is low. Thus, annual lespedeza can greatly enhance a tall fescue pasture, especially if the fescue is highly infected with toxic endophyte.

Numerous winter annual forage crops can be used to complement the grazing seasons of warm-season perennial forages and, depending on which one (or what mixture) is planted, the period during which they make forage growth may be quite different. Annual ryegrass, which makes most of its growth in early- to mid-spring, is a particularly productive winter annual in areas where it is adapted. By contrast, small grains such as rye, wheat, and oats are more productive in autumn. In the extreme northern areas of the country, spring-planted winter cereals such as spring barley, oats, or triticale may be used to provide forage growth in late spring, summer, and into the autumn.

Annual legumes, which are widely used in the Deep South, vary from making most of their growth in early spring (e.g., crimson clover) to being most productive in late spring and even early summer (e.g., arrowleaf clover and hairy vetch).

Winter annuals can be grown on a prepared seedbed, seeded into a warm-season perennial pasture, or into crabgrass stubble. In any of these situations, total yield and calendar days of grazing will be increased as compared to having only warm-season pasture. Planting winter annuals on a prepared seedbed, or no-

till planting them into crabgrass stubble can usually be accomplished earlier than overseeding them on bermudagrass or bahiagrass, allowing earlier grazing.

## Timely planting

Weather often dictates planting dates, but it pays to be ready to plant as early as possible within the recommended planting period for a particular crop. This applies more to annuals than to perennials, but the earlier you can safely plant, the earlier you can begin grazing. It is important to avoid grazing too early, however, or stand damage may occur.

## Variety selection

Growth distribution differences exist among many varieties within species. For example, some varieties of annual ryegrass complete growth in mid-spring, while others can make a substantial amount of growth in late spring. Some tall fescue varieties (summer dormant types) produce more winter growth than others. Some alfalfa varieties are highly winter dormant and quickly cease growth under cool temperatures, while less-dormant varieties may make a considerable amount of growth under identical conditions.

A review of variety test data, especially if multiple years of testing have been summarized, allows identification of such growth differences. Forage distribution should not be the only variety selection criterion, but it deserves consideration, especially if one is deciding between two or more varieties that are similar with regard to other characteristics such as dry matter yield, forage quality, and disease resistance.

## Stockpile forage

Stockpiling (also referred to as deferred grazing) can be defined as the managed accumulation of vegetative growth to be used at a later time. In the context of this publication, stockpiling refers to accumulating standing forage for grazing by livestock. Most stockpiling is done to extend grazing into autumn and winter, but in some situations it can also be useful in keeping animals grazing when dry periods during the growing season slow forage growth.



**The growing seasons of various annual legumes vary, even for varieties within species.**

## Stockpiling tall fescue

Nearly any type of forage can be stockpiled, but tall fescue is the species most widely used for this purpose. Tall fescue typically makes a good amount of growth in autumn, it has a waxy layer on its leaves that makes them resistant to frost damage and weathering, and grazing to a low winter residual height has little effect on its spring regrowth or stand density. In addition, tall fescue forage accumulates a high concentration of soluble carbohydrates in the fall. The result is that stockpiled tall fescue not only has good forage quality, it maintains this quality extremely well through the winter. In fact, the total digestible nutrient (TDN) and crude protein (CP) content of stockpiled tall fescue is typically significantly higher than the average hay fed to beef cattle (figure 1).

Stockpiling may also help reduce the toxicity of endophyte-infected tall fescue. A 2001 study showed that levels of the toxin ergovaline found in endophyte-infected fescue dropped during the winter grazing period (figure 2). In light of the slow decline in protein content and digestibility of stockpiled fescue forage, this makes a strong case for delaying the use of stockpiled toxic endophyte fescue as long as possible into the winter months. This can be done by grazing winter annuals or stockpiled summer forage first.

## Stockpiling other forage crops

Other cool-season perennial grasses such as orchardgrass and smooth bromegrass can be stockpiled for late fall grazing, but are less desirable than fescue. The quality of stockpiled forage of these grasses declines more rapidly, plus these species have less persistence under heavy grazing during the winter, and stands may thin

in subsequent growing seasons. Stockpiled forage of these species should be grazed within a few weeks after a hard freeze.

Legumes, such as red clover, and cool-season annual grasses, such as annual ryegrass and small grains (including wheat, rye, and triticale), may also be stockpiled, but the stockpiled forage deteriorates rather quickly. These forages usually work best when used for autumn and late winter/spring grazing. When used in this manner, they provide high-quality grazing before and after the use of stockpiled fescue, and bridge the gap between stockpiled fescue and spring growth of cool-season perennials. Near the Gulf Coast, cool-season annuals may provide at least some forage growth for grazing essentially throughout the winter.

Warm-season perennial grasses such as bermudagrass, bahiagrass, old world bluestems, big bluestem, indian-grass, and eastern gamagrass, as well as warm-season annual grasses such as crabgrass and sweet sorghum have

**Figure 1.** Comparison of stockpiled tall fescue quality to average hay quality.

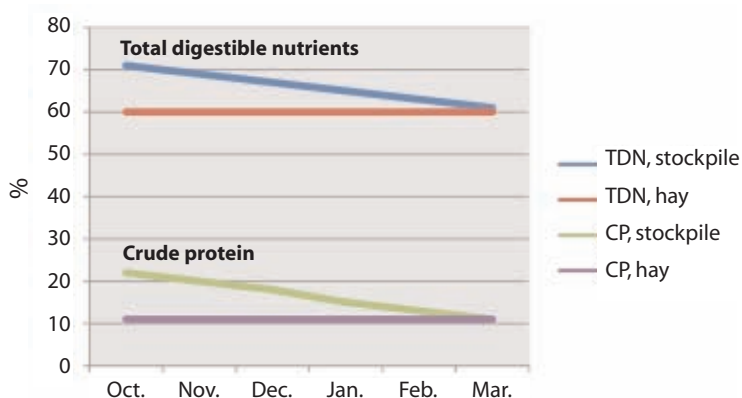

Source: Mark Kennedy, Missouri, 1997–2003, and John Jennings, Arkansas, 1998–2002.

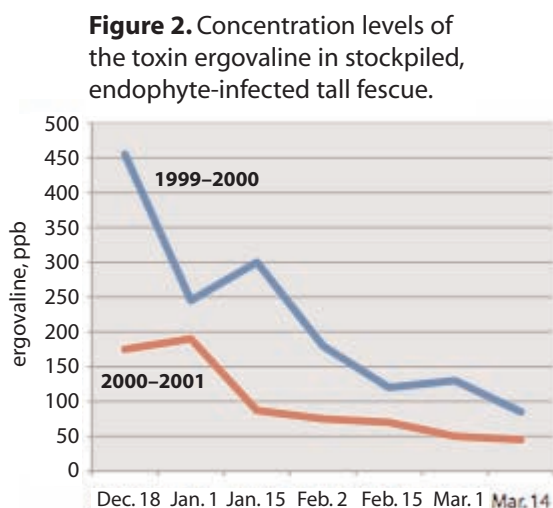

Source: Rob Kallenbach, University of Missouri, 1999–2001.

also been successfully used for stockpiling forage. It was once thought that protein and energy levels of stockpiled warm-season perennial grasses drop too low to be of much value as livestock feed, but in studies in Oklahoma with bermudagrass, protein levels stayed above 10% and energy did not drop significantly, especially if harvested by the end of December.

On-farm data collected in Missouri has shown that crude protein levels of stockpiled old world bluestems and native warm-season grasses dropped to 7 to 9%, but TDN (total digestible nutrient) levels generally stayed between 58 and 60%. Livestock acceptance of stockpiled switchgrass has been poor in some climates, so stockpiling monoculture stands of switchgrass should generally be avoided. Grazing eastern gamagrass during winter has resulted in some crown damage and subsequent stand thinning.

With these types of grasses, a protein supplement would be needed for most classes of livestock. However, an approach that has worked successfully in Oklahoma and Missouri is to limit graze cool-season annuals or stockpiled tall fescue for the purpose of using the grass as a protein supplement on dormant warm-season grasses. Work at the Noble Foundation in Ardmore, Oklahoma has shown that as little as 30 minutes of grazing of a cool-season annual pasture per day can meet livestock protein needs.

Corn is generally considered a summer row crop or silage crop, but it can also be grazed during late summer or autumn or be allowed to mature and then be grazed as standing corn. Corn seems to have much potential for stockpiling in view of its high energy value and its high yield potential. However, to prevent excessive waste, daily strip grazing is advisable.

## TECHNIQUE FOR STOCKPILING TALL FESCUE

The following steps have proven successful for stockpiling tall fescue forage:

1. At 60 to 90 days before the end of the fall growing season, graze or clip pastures leaving 3 to 5 inches of forage growth.
2. Immediately after grazing or clipping, apply 40 to 80 pounds of nitrogen per acre. Both the rate and timing of nitrogen fertilizer have an important impact on yield (see figure 3). Applying fertilizer earlier than 90 days before the end of the growing season will not significantly increase the yield, but quality will be significantly lower. Delaying initiation of stockpiling will result in higher quality forage, but lower yields.
3. Defer grazing stockpiled tall fescue forage until late fall or winter. Be sure to properly use forage growth in other pastures before beginning to use stockpiled forage. However, late-season growth of warm-season species may be of low quality and thus may require supplementation.
4. If possible, stockpile 1 acre per cow. Under normal conditions this will give a 75- to 90-day feed supply if grazed properly. (A 1,000-pound cow eating 2.6% of her body weight per day in dry matter consumes 26 pounds of forage per day. An acre of fescue stockpiled for 90 days typically produces 3,000 pounds of forage. Assuming 70% efficiency during strip grazing, this translates to 2,100 pounds of usable forage, or about 80 days worth of food.)
5. Although low quality, highly perishable material such as crop residues or stockpiled warm-season forage should be used first, once the use of stockpiled fescue has begun, start with the highest quality stockpiled fescue forage, because weathering causes more value loss in high-quality material than in low-quality material.

Accumulation of high-quality forage should begin about 60 to 90 days before the end of the growing season.

**Figure 3.** Tall fescue stockpile yields at various nitrogen rates and application dates.<sup>a</sup>

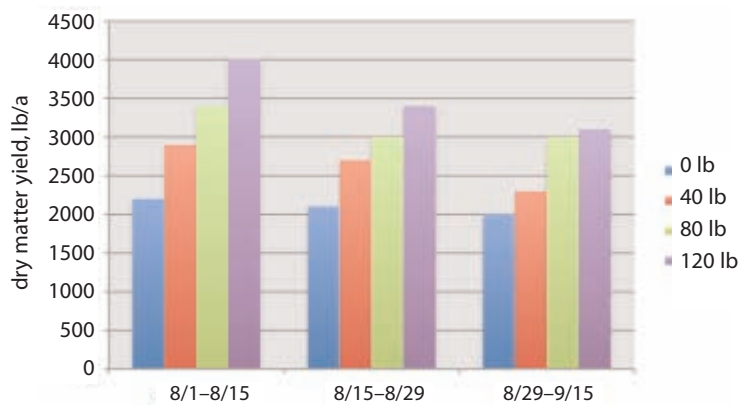

<sup>a</sup>Geographical location will affect the suitability of various dates of application.

Source: Jim Gerrish, University of Missouri, 1997.

Regardless of the species stockpiled, accumulation of high-quality forage should begin about 60 to 90 days before the end of the growing season. Allowing pasture to grow for longer periods will result in low-quality forage (due to excess dead residue), which in turn will translate to poor animal performance. The same holds true for forage that has been allowed to accumulate in waterways or along field borders. Unreasonable expectations regarding the forage quality of such material is a common reason for producer disappointment with stockpiling.

### Use stockpiled forage efficiently

Once forage has been stockpiled, using it efficiently is important in developing a low-cost winter feeding system. The most economical way is to strip graze the pastures. By allocating forage in strips calculated to be used within 3 days, animals consume 70% or more of the forage; by comparison, when given access to a 2-week feed supply, animals will consume 40% or less of the forage. That difference allows a significantly longer grazing period of quality forage for livestock. Many producers like to allocate a new

strip every other day, which works well. If stockpiled grass is available, hay will only need to be fed if there is a deep cover of snow (6 inches or more). However, as little as 1/4-inch of ice alone or as a crust on snow may prevent grazing of stockpiled forage.

## Take advantage of unique grazing opportunities

### Graze crop residues

In mixed crop and livestock operations, residue in corn and grain sorghum fields can be used to provide a substantial number of days of grazing. When grassed waterways, terraces, and field borders are present and are properly managed and used, this option becomes even more attractive. Iowa State University Beef Cattle Center data indicates that for each acre of corn stalks grazed, approximately 1/2 ton of hay will be saved.

Crop residues are normally the least expensive feed source, because most expenses are charged against the row crop enterprise. The cost of grazing

corn crop residue is about 5 cents per day according to Iowa State University beef cow business records. In a 4-year summary of experiments, cows grazing corn crop residue at 2.5 acres/cow per season for 112 to 174 days required about 1 ton less hay per cow to maintain adequate body condition than cows maintained in a dry lot. In a 5-year study conducted by Dr. Jim Russell at Iowa State University, 113 grazing days were obtained when cornfields were grazed after corn harvest with a stocking rate of 1.9 acres per cow.

An entirely different situation may exist in some areas where wheat or other cool-season annual crops are grown in autumn and/or spring and harvested in late spring or early summer. In such cases, after harvest there may be a combination of straw or other plant material as well as volunteer weeds and grasses that can provide summer grazing.

Crop residues usually represent about half of the pre-harvest plant dry matter. For example, a field producing 120 bushels of corn grain (about 7,200 pounds) will contain 3 to 4 tons of roughage dry matter per acre. Depending on stocking rate and grazing method, cows grazing corn-stalks or grain sorghum stubble will consume 25 to 30% of the available residue in 30 to 100 days, still leaving enough material to prevent soil erosion.

In the Midwest, corn crop residue will feed animals for an average of 65 to 111 days. The optimal grazing allowance on corn crop residue fields will depend on the weight gains necessary to obtain a desired body condition. With low supplementation, cows can maintain body weight with as little as 1/2 acre of corn crop residues per cow per month, but may need as much as 2 acres per cow per month if weight gain is desired.

**Table 1.** Relative amounts and values of corn residue plant parts.

Item	Plant parts			
	Husk	Leaf	Stem <sup>a</sup>	Cob
Residue (% of total dry matter)	12	27	49	12
Crude protein (% by plant part)	3.6	7.8	4.5	2.2
<i>In vitro</i> dry matter disappearance (%) <sup>b</sup>	67	47	45	35
Palatability	high	high	low	low

<sup>a</sup> Includes leaf sheath.

<sup>b</sup> A measure of dry matter digestibility determined by a laboratory analysis.

Source: Wilson, C.B., G.E. Erickson, T.J. Klopfenstein, R.J. Rasby, D.C. Adams, and I.G. Rush. 2004. A Review of Corn Stalks Grazing on Animal Performance and Crop Yield. University of Nebraska 2004 Beef Research Report.

Livestock select the portions of crop residues with the highest digestibility and protein concentration first (table 1), so supplement needs beyond trace mineral salt and vitamin A are likely to be minimal for the first month of grazing. Providing simultaneous access to stockpiled grass or late summer growth of legume forages may supply protein and energy, and thereby reduce needs for supplementation. As winter progresses and crop residue quality decreases because of grazing selection and weathering, supplementation of protein and phosphorus may become necessary.

As with stockpiled forage, strip grazing crop residues allows more efficient use, resulting in more grazing days, and helps ensure a high-quality diet over a longer period of time by reducing selective grazing. A caution associated with grazing corn crop residue: Livestock may overload on excessive amounts of grain left in the field, putting them at risk of founder (or acidosis), a serious digestive problem. Strip grazing reduces the likelihood of this disorder.

## Graze dormant alfalfa

In the northern portion of the United States it is recommended to allow alfalfa growth to accumulate for about 6 weeks before the first killing frost is anticipated. This allows alfalfa plants to replenish root carbohydrate reserves before winter. However, once plants are dormant, the accumulated growth can be grazed by livestock. This should be done promptly, before the frozen leaves drop off. An added benefit of grazing the frosted forage is that it tends to reduce alfalfa weevil populations the following spring in southern areas. In northern areas, leave roughly 3 to 4 inches of stubble to catch and hold snow to reduce winter damage and minimize temperature fluctuations that may result in plant heaving.

## Graze hayfields

The need for stored feed is most commonly associated with cold temperatures that limit forage growth during winter, but other climatic conditions such as drought or an unexpected need to pasture more animals than planned may also make supple-

mental feeding necessary. In such a situation, it can be advantageous to graze a hayfield provided species-appropriate residual stubble heights and a suitable rest period are provided. (although for a few forage species late summer grazing or grazing closer than a certain minimum stubble height may hurt winter survival and/or spring growth).

It usually isn't possible to accurately predict how much hay will be needed. Thus, it may turn out that a producer will have enough hay whether or not a hayfield is grazed. Regardless, grazing a hayfield may "buy time" that makes it possible to carefully evaluate the situation and implement other strategies to reduce stored feed needs such as culling of animals, planting of winter annuals, or locating a relatively inexpensive source of hay or an alternate supplemental feed (grain or a by-product of crop processing, for example). Meanwhile, the expense of harvesting the forage as hay has been avoided, and the cost of purchasing hay or other stored feed at a later time may be little more (or even less) than making hay from the forage growth that would otherwise have accumulated.

## GRAZING CROP RESIDUES: ADDITIONAL POINTS

- Before grazing crop residue fields it is important to check the labels of any pesticides used on the crop to see if they are cleared for grazing crop residues. Label restrictions should be strictly observed.
- It is advisable to make certain no poisonous plants are present in fencerows or other areas adjacent to fields in which crop residues are to be grazed. Forage produced in fencerows and waterways within row crop fields is of most value if mowed, fertilized, and managed as stockpiled forage, as discussed earlier.
- Research conducted at several Midwestern universities shows no difference in the performance of cattle that grazed Bt corn crop residue and those that grazed non-Bt corn crop residues.
- Research has been conducted in several Midwestern states to determine if winter grazing of row crops had any impact on crop yields the following year. Corn and soybean have shown similar yields for grazed and ungrazed fields, particularly if grazed when soils are frozen.



**Crop residues can be an inexpensive source of nutrition.**

- Soybean stubble is low in quality and cannot provide adequate nutrition for beef cows or stockers. It should not be used as a feed source unless supplemented substantially.

## Use other plant growth

Grazing animals, especially ruminants, have the unique ability to digest plant material and convert it into meat, milk, and fiber. Innovative livestock producers around the world who see forage as a resource are always on the lookout for low-cost or free sources of nutrition for their animals. In some nations it is common practice to graze animals in public areas such as road rights-of-way. In addition, in some countries shrubs, in addition to grasses and forbs, are cultivated specifically for the purpose of providing nutrition for cattle, sheep, and especially goats. Here in the United States it is not unusual for producers in some areas to graze volunteer growth in old crop fields, swampy areas, or woodlots. It is important to meet animal nutritional needs, and to avoid exposing grazing animals to poisonous plants or other dangerous situations, but staying alert to unique grazing opportunities makes sense and can help reduce costs.

## Forage or livestock management approaches

### Grazing management

Good grazing management yields numerous benefits, including several that deserve mention here. First, when pastures are grazed appropriately for the forage species they contain, the plants will be healthier and more productive over a longer period of time, thus reducing the need for other strategies. Grazing plants too closely will slow regrowth, resulting in lower yields, and will also weaken plants due to depletion of food reserves. Forage crops such as upright-growing bunchgrasses that store much of their food reserves in stem bases are particularly sensitive to this type of damage. Healthy plants with good root systems are impacted less by drought and other stresses than are plants that have been weakened by overgrazing.

Good grazing management also reduces forage waste. If pastures are undergrazed at certain times (which often occurs with poorly managed continuously stocked areas), losses due to trampling and fouling of forage can be substantial. A number of grazing practices can reduce forage losses by 20 to 30%, which can in turn lengthen the grazing period. These techniques include limit grazing (giving animals access to a pasture for only a few hours at a time), strip grazing (allocating only a strip of pasture forage to animals at any given time), forward grazing (giving animals having higher nutritional requirements first access to a pasture), and rotational stocking (rotating animals among pastures or paddocks).

With rotational stocking, it may be possible to begin grazing earlier in the growing season while staying within the realm of good grazing management. This is because removing animals from an early-grazed pasture allows the grass to rest before being grazed again. Since the first pastures grazed are likely to be slower to recover, this approach may also help avoid some of the excess growth problems that often occur during the spring flush. Shortening rotation intervals tends to result in forage growth being better distributed over the growing season as long as pastures are not grazed more closely than recommended for the species they contain.

Grazing management can also help ensure animal nutritional needs are met. For example, creep grazing allows young animals to obtain a more nutritious diet than their mothers; forward grazing allows groups of animals grazed in sequence to consume forage of differing quality levels; and limit grazing a high-quality pasture (perhaps 2 or 3 hours every other day) can provide excellent dietary supplementation.



Finally, as grazing management is intensified, there is usually more even distribution of dung, urine, and therefore of recycled nutrients. This tends to ultimately reduce fertilizer needs, increase the efficiency of fertilizer applications, and keep pastures growing for longer periods of time. However, under wet soil conditions a concentration of animals may create extremely muddy conditions and result in much pasture stand damage. A “sacrifice” paddock that can be reseeded later may therefore be justifiable.

Workers in Georgia compared continuous and rotational stocking. Rotational stocking resulted in dramatic increases in stocking rate and calf gain per acre (table 2). It also resulted in a 32% reduction in amount of hay required per cow by extending the grazing season.

In Missouri, researchers compared strip-grazing intervals of cattle grazing stockpiled tall fescue. When forage was allocated in a 3-day supply compared to a 14-day supply, cow-days per acre were increased by 32 days, with a 56% increase in carrying capacity. The extra days on pasture translates to a corresponding reduction in the amount of hay required, reducing the cost of wintering animals (table 3).

## Irrigation

Pastures often become unproductive or go dormant in mid- to late summer due to lack of water. Irrigation may relieve the situation, but before proceeding with this alternative, landowners should thoroughly consider all the issues that contribute to irrigation system cost:

- Is there an inexpensive source of water available? Water sources vary greatly in cost, so this should be carefully checked. During hot weather, some plants require approximately 0.25 to 0.30 inches per day. Check with a knowledgeable irrigation specialist for water requirements in your area. One inch on one acre is 27,158 gallons, so the water supply must be able to supply a minimum of 7,000 to 8,000 gallons per acre per day (after evaporation and other losses) to be effective for irrigating any field or pasture.
- Pumping from streams frequently requires a permit from the U.S. Army Corps of Engineers and/or the state agency or regional water district responsible for natural resources. If irrigation is desired by a certain time, there should be an assessment as to how long it will likely take to acquire permits and install equipment. Permit time can be up to 12 months, depending on the on-site physical situation.

**Table 2.** Comparison of animal gain and winter hay requirements using continuous and rotational grazing systems.

	———Grazing systems <sup>a</sup> ———		Change, %
	Continuous	Rotational	
Stocking rate, cow-calf units/acre	0.50	0.69	+38
Calf weaning weight, lb	500	496	0
Total calf gain/acre, lb	248	340	+37
Cow pregnancy rate, %	96	95	0
Hay fed/cow, lb	2,570	1,750	-32

<sup>a</sup>Beef cattle grazed stockpiled tall fescue (‘AU Triumph’).

Source: Dr. Carl Hoveland, University of Georgia.

**Table 3.** Daily and seasonal forage costs for alternative wintering strategies at typical yields, costs, and period of use based on a 100-cow autumn-calving herd. Winter feeding period from December 1 to April 10.

Item	Hay	Cornstalks	Stockpiled tall fescue	Ryegrass + cereal rye
\$/cow/day <sup>a</sup>	100%	4%	23%	46%
Days of use	130 (hay)	60 (stalks) 70 (hay)	90 (graze) 40 (hay)	90 (graze) 40 (hay)
Wintering cost <sup>a</sup>	100%	71%	41%	63%

<sup>a</sup> Expressed as a percentage of hay.

Source: Jim Gerrish, University of Missouri.

- Will irrigation of pastures be cost effective? The quantity and value of forage produced on average must be enough to justify installing the system plus the expense of operating it. Typically, irrigation must be used hundreds of hours each year for many years to be economical.
- Irrigation equipment application efficiency should be considered. Newer pivot irrigation equipment may have 85% or higher efficiency (% of water pumped that is made available to plant), but older systems, particularly traveling guns, may only be 60% efficient. Lower efficiency means more water and more pumping energy is needed to get water application rates and yield responses comparable to higher efficiency systems.
- Labor to operate irrigation equipment should be considered. Pivot irrigation systems are the least labor intensive at about 0.0125 hour per acre. Traveling gun or tow irrigation systems may need ten times that (about 0.15 hour per acre).
- With irrigation automatically comes the need for balanced and often increased fertilization. Irrigating malnourished pastures is a waste.
- In some areas, soil types, or situations, soil compaction caused by the hooves of grazing animals (which is greatly intensified when soil is wet) or eventual soil salinization may be a concern.

If these issues can be resolved, pasture irrigation may be a consideration, but it should be a long-term commitment, not a “knee-jerk” reaction to one or two years of drought.

Forages respond to irrigation at any vegetative stage. The yield increase is linear to the total water applied up to the amount needed by the plant for daily growth. The critical question is whether the extra pasture forage that may be produced on average will be worth the cost. An effective pasture irrigation system is generally not much less expensive per acre than an effective row crop irrigation system.

## Fertilization and liming

A simple and cost-effective strategy for extending the grazing period is to maintain a proper fertilization program. Well-fertilized, vigorous plants begin growth earlier and resist stresses such as drought better than weaker, nutrient-deficient plants. Soil testing and applying lime and fertilizer to pastures according to recommendations is important.

Fertilizer can be used as a management tool to optimize production when good growing conditions exist, and to increase forage production just before times of slow plant growth. Thus, application of fertilizer can shift the timing of availability of pasture forage, although this is contingent upon adequate moisture being available for plant growth.

Nitrogen (N) is the most common limiting nutrient. Each growth cycle of a pasture generally takes up most of the soil N available, leaving little for the next growth cycle. This means that periodic applications must occur during the season. Typically, two or three applications of 40 to 60 pounds of N per acre are recommended during the growing season, with the first application being made at

greenup of the species most desired in the pasture. By splitting applications, some of the high points in the growth curve are a bit flatter and forage quality during the growing season tends to be more uniform.

Failure to have adequate N available for plant growth in early spring at the beginning of the growing season of perennial grasses is a common reason for delayed spring forage growth. (Note: Application of N to a grass/legume mixture may shorten stand life of the legume.) In situations where volunteer species that may be considered desirable are present (for example, annual ryegrass and/or wild barley in a bermudagrass pasture in early spring), it may be justifiable to fertilize several weeks earlier than normal. Conversely, on farms where there is typically a huge excess of spring growth, it may make sense to postpone the first application until later in the season.

In drier areas, providing good fertilization in spring when rainfall is likely may provide stockpiled grass for use during low rainfall periods in summer. Rotational stocking of pastures results in more even distribution of recycled nutrients (in the form of manure) as well as a higher percent utilization of accumulated pasture forage. Manure, whether directly deposited by livestock or applied, represents a slow-release source of nutrients that favors pasture growth over time. However, excessive phosphorus, regardless of the source, is environmentally undesirable.





Missing later fertilizer applications may limit growth for late summer grazing or stockpiling. Initiating fertilizer applications at different times to different paddocks or pastures may result in forage production peaks at different times.

Keeping the soil pH at a level that is suitable for growth of the forages being grown (or to be grown) is also essential for good production and a long grazing season. The soil pH requirements for growing many legumes is higher than that of forage grasses, and thus it is especially important to lime the soil in accordance with soil test recommendations in order to obtain good legume establishment, production, and persistence.

**Get the most benefit from your pastures by having animals with higher nutritive requirements graze the best-quality forage.**

## Other useful concepts

### Match forage quality and nutrient intake to animal needs

Another strategy can be to carefully match animal needs to forage quality. Different animal types and classes have different forage quality needs (figure 4). You can get the most benefit from your pastures by having animals with higher nutritive requirements graze the best-quality forage and using lower-quality forage in the rations of animals with lower nutritive requirements.

The nutritional needs of breeding female livestock vary greatly during the year, with the greatest nutritional demand occurring during early lactation. This leads to varying requirements for forage quality and quantity at various times. For example, in a beef cow/calf operation using a late winter

or spring calving schedule, calves have high needs for energy and protein to make good gain late in summer, while dry, pregnant cows can be on a maintenance diet. Thus, calves should receive good quality pasture while cows can be supplemented with lower quality hay or pasture.

Having a controlled breeding season and calving at a time that allows animal nutritional needs to match the quality and quantity of available pasture forage are keys to both good animal performance and reduced supplemental feeding. Depending on calving dates, the ease of providing appropriate quality pasture forage may vary greatly. In an area where winter annuals can be easily grown, autumn calving (which lowers cow nutrient requirements in early spring) may work well. Late winter or spring calving may be more suitable for producers who rely primarily on cool-season perennials. (Note: Rebreeding during warm weather, especially if animals are grazing toxic endophyte tall fescue, may not work well.)

**Figure 4.** Forage quality needs of cattle.

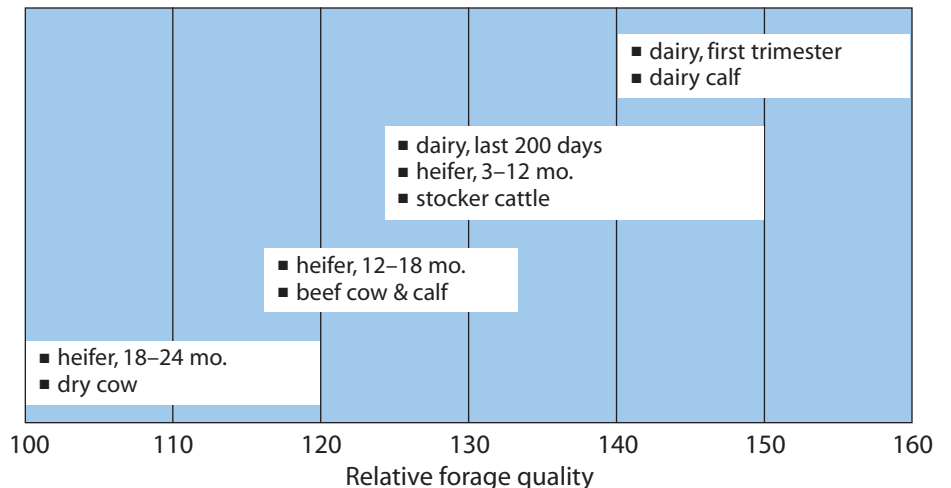

Forage testing—or, in a range or pasture, fecal analysis—is a tool livestock producers can use to make better use of their pasture, hay, and silage. Knowing the quality of the forage available and matching that to animal needs allows producers to ensure acceptable animal performance while minimizing supplements. When pasture is running short, grain (or grain processing by-products) rather than hay may be the most cost-effective supplement.

Beginning to provide supplementation as pasture growth slows will ensure high energy and good animal response while substituting for some forage. It may make it possible to stretch the pasture through the period of low production by lowering forage intake. This, in turn, may keep a pasture from being overgrazed and subsequently being slow to recover.

## Change the stocking rate

It may be beneficial to lower the stocking rate to match pasture growth and production. The major reason that most beef producers calve in late winter or spring is to have plentiful, high-quality pasture available for the growing calves and milking beef cows during April, May, and June. When forage production begins to decline, some method of reducing animal numbers will leave forage available for the remaining animals during the rest of the summer and fall. Options include:

- Move cows to an area that provides lower-quality forage. This effectively reduces the number of animals on a given pasture.
- Wean calves early and sell some in midsummer. As calves (or stocker cattle) grow, their forage requirement increases at a time when

pasture production is typically declining. For a cow-calf producer with a late winter- or early spring-calving herd, selling the largest calves in early August could free up sufficient pasture to feed the remaining herd for the rest of the season. Lighter animals sold in early August usually sell for more per pound than heavier animals sold in September when a glut of animals reach the market.

- Retain ownership of calves, but move a portion to feedlots in early August. If managed properly, the remaining herd on pasture may be able to remain longer and be sold at higher prices later in the year.
- In a breeding herd, cull open mature animals before the winter feeding season. Reducing animal numbers in late summer and autumn may also allow stockpiling tall fescue or other forage species. Some producers might opt to keep a small enough number of breeding animals to allow getting through the winter without needing much stored feed, and then purchase calves or other livestock to graze during the spring flush.

Keep in mind that overstocking usually leads to overgrazing, lower forage yields, and reduced animal performance, as well as to higher amounts of stored feed needed. On farms where stored feed needs are consistently high, it may be that some reduction in overall stocking rates should be considered.

## Use winter annuals in crop rotations or to supplement perennial forages

In much of the United States, winter annuals can be useful in helping provide an extended grazing season. On farms where row crops are grown, winter annuals can allow use of cropland all 12 months of the year while providing a cover for the soil during winter. In combination with crop residues and fall growth of annual crops, this can allow livestock grazing to be extended well into the winter months.



Winter annual crops can also be valuable when planted in areas where lower quality perennial forages dominate or to provide grazing at times when it would otherwise not be available. However, because winter annual forages are more costly to grow than most perennials, they may be most economical to use primarily for growing and saleable animals unless mature animals are to be second grazers.

## Brassicas

Brassicas (including turnips, rape, kale, and swedes) are highly productive, digestible forbs that contain relatively high levels of crude protein. Animals will readily consume the tops and will also grub the root bulbs out of the ground. These crops are best suited for crop rotation pastures or for being no-tilled into light sod. Dry matter yield is variable and highly dependent upon soil type, fertility, time of seeding, and precipitation. However, continuously growing them on the same land may lead to a high incidence of crown or root rot within a few years.

- **Turnips** grow fast and can be grazed as early as 70 days after planting. They reach near-maximum production level in 80 to 90 days. The proportion of top growth to roots for turnips can vary from 90% tops and 10% roots to 15% tops and 85% roots. Turnips can be seeded any time from when soil temperature reaches 50°F until 70 days before a killing frost.

Note: Sheep producers need to be aware that copper toxicity can be a problem with turnips.

- **Rape** is more easily managed for multiple (more than two) grazings than are the other brassica species. Rape can generally be grazed at 4-week intervals. Leave approximately 6 to 10 inches of stubble after the first grazing to promote rapid regrowth; on the final grazing, plants should be grazed close to ground level. Rape can cause sunburn (scald) on light-skinned animals, especially if it is grazed while the plants are immature.

- **Kale** has more variation among varieties than most other brassica species. Some varieties may provide grazing after about 90 days, followed by a regrowth opportunity; others may require as much as 180 days to mature. Dry matter yield of kale can be impressive.

- **Swedes** (also known as rutabagas), like turnips, produce large edible roots. Swedes yield more than turnips, but require 150 to 180 days to reach maximum production. Swedes is one of the best crops for fattening lambs and flushing ewes. Yield is maximized with a 180-day growth period for many varieties, but most hybrids produce the greatest yields when allowed to grow 60 days before first grazing and 30 days before the second grazing.

Brassicas should not comprise more than about two-thirds of cattle diets because of their low dry matter content. Therefore, it is important to provide adjacent pasture, corn stalks, or a palatable, dry hay fed free choice to cattle when grazing these crops. It is also desirable to introduce them to brassicas slowly by limit grazing for a couple of hours per day until their digestive systems are accustomed to them.

Brassicas require good soil drainage, and soil pH should be in the range of 5.5 to 6.8. Brassicas can be seeded into wheat stubble or no-tilled into a sod, provided it has been killed with glyphosate. Clean-till seeding works well, but may have increased insect pressure. If seeding after crop farming, herbicide carryover residues can be an enormous problem. As a rule, carry-over label recommendations for sugar beets are usually applicable to most brassica species. Some producers in the Upper Midwest have had success in aerially seeding turnips into standing corn in mid-August. The corn must be physiologically mature for this to be successful.

Fertilizer should be applied at the time of seeding to give brassicas a competitive edge on weeds. Normally 75 to 80 pounds of nitrogen per acre and any phosphorus and potassium needed should be applied similar to what would be applied for a small grain. Good soil moisture following seeding is key to successful establishment.

As with stockpiled forage, brassicas should be strip grazed. If regrowth is desired, at least 2 inches of leaf should be left intact. Generally animals will consume the leafy portion of the plant before progressing to the root portion. To encourage consumption of roots, it may be necessary to disk after the tops have been grazed.

## Small grains

Cereal crops such as wheat, rye, oats, barley, or triticale can provide autumn or early winter grazing opportunities. However, certain management practices need to be modified from what is normally done for grain production. When small grains are used for grazing, they should be planted 3 to 4 weeks earlier than for grain production. Also, between 60 and 100 pounds of nitrogen per acre is normally applied at planting time (check local recommendations).

Recommended seeding rates vary depending on establishment method and seeding combinations.

Rye is more productive than wheat or triticale for both fall and spring production. However, forage quality is better with triticale than with rye. Oats seeded in the fall can be excellent quality and very productive, but will be killed by cold weather during winter (except in the Deep South). Depending on geographical location, with adequate fall moisture, rye, triticale, and wheat should be available for grazing from October through much of December and then again in early spring.

The intended use of small grain determines what the stocking rate and grazing dates should be. If a silage or grain harvest is planned, grazing should only be moderate, as heavy grazing can reduce grain yields. Moderate grazing in the autumn will not result in significant silage or grain losses provided moisture and soil fertility are adequate. In fact, fall pasturing can be beneficial where the small grain was seeded early and has made excessive growth and soil conditions are dry. Spring grazing may be started when growth resumes. If a grain or silage crop is to be harvested, grazing should be discontinued when the plants start to grow erect, just before jointing (growth stage); otherwise grain yield will be reduced.

Seeding date has a major impact on how early small grains can be grazed. If the goal is to graze in late fall, seeding should be completed by late August in the Midwest and by late September in the Deep South. With adequate moisture, growth will continue until air temperatures drop to around 40°F. Remove livestock when 3 inches of growth remain to maintain sufficient leaf area for continued growth and recovery.

## Annual ryegrass

Annual (or Italian) ryegrass can be used as a companion species with, or as an alternative to, the small grain cereal crops to provide grazing in late autumn, early winter, and spring. Compared to small grains, ryegrass is easier to manage, has a higher feed quality, and fewer management problems in spring, and can make rapid regrowth after initial grazing.

Annual ryegrass can be easily established into standing corn or soybeans or in these or other summer row crop fields after harvest. It can also be no-tilled into old alfalfa fields. There are differences in winterhardiness among annual ryegrass varieties, so if spring grazing is desired, it is important to plant varieties that are known to be adapted. Seeding rates vary according to planting method and combination of species. (Check local recommendations for specific seeding information.) Wait to graze winter annual grasses until at least 8 inches of growth have accumulated.

## Winter annual legumes

In climates and management situations in which plants are likely to persist, it is generally advantageous to grow perennial rather than annual legumes. However, in the Deep South, where perennial legumes such as white clover usually act like annuals, any of several winter annual legumes are a usually a better choice, depending on soils, rainfall, and producer objectives. Various species may be grown alone, with another annual legume, or in combination with winter annual grasses.

Winter annual legumes make almost all of their growth in late winter and spring, but the distribution of growth of various species within this time period varies greatly. Some row crop producers plant winter annuals as cover crops to provide nitrogen for a summer row crop, improve soil tilth, and protect the soil during winter. Of course this forage can also be grazed in late winter or spring. Hairy vetch is hardy enough to be grown as far north as the Lower Midwest, but it produces most of its growth during a few weeks in mid-spring.

## Overseed winter annuals on summer grass sods

Winter annuals, including annual ryegrass, small grains, and various annual legumes such as clovers and vetches can be seeded as a single species or in various mixtures into warm-season perennial grass sods such as bermudagrass, bahiagrass, or dallisgrass to extend the grazing season by 30 to 60 or more days. Winter annuals should normally be overseeded about 2 or 3 weeks before



**Extend the grazing season by 30 to 60 days or more by overseeding winter annuals on summer grass sods.**

the expected date of a killing frost. Unless some tillage is provided to ensure good seed-soil contact, the existing grass should be clipped or grazed to 1 to 2 inches tall. Producers who have pastures of both tall fescue and summer perennial grasses may be able to graze their summer grass closely to facilitate overseeding of winter annuals at the same time they are stockpiling tall fescue. Overseeded pastures should be kept grazed closely in spring to prevent shading of summer species.

## Provide supplemental feed during warm weather

Despite the best management plans, shortages of forage commonly occur during July and August in the cool-season grass region due to drought or overstocking. When this happens, supplemental feeding of hay or grain by-products in July and August might be used to avoid overgrazing. Also, a pasture or paddock of summer annual grass might be planted in anticipation of reduced pasture availability.

In areas where cool-season perennial forages dominate pastures, if pastures are short or pasture forage is of poor quality in July and August, feeding animals in a dry lot might be an option. This may be more cost effective than overgrazing or trying to supplement animals on overgrazed pastures. There is less hay loss when feeding hay in summer months as compared to winter. Also, this approach allows pastures to begin recovering from overgrazing or drought and provides an opportunity to stockpile for late fall and winter grazing. Using the same logic, some producers might also consider feeding hay in late summer or autumn to allow stockpiling of tall fescue forage.

Once livestock are removed from pastures, it may be worthwhile to apply 30 to 60 pounds per acre of nitrogen to stimulate plant recovery. During hot weather, use of ammonium nitrate may be advisable as surface-applied urea can lose significant amounts of nitrogen through volatilization. If using urea, the application should be made just before a rain to minimize the exposure time of the fertilizer material on a dry soil surface.

## Minimize hay losses

This publication emphasizes the value of grazing, but most livestock producers will need to provide hay or some other stored feed at certain times during the year. Losses during the harvesting, storing, and feeding of hay vary considerably. Ranges in losses are included in table 4. Given the worst-case scenario, animals may consume only about 29% of the forage present in a hay field at harvest. Further, the more hay wasted, the more that must be produced or purchased to feed animals at times when adequate pasture forage is not available.

The value of hay storage and feeding losses alone in the United States are estimated to exceed 3 billion dollars annually. On some farms, hay storage and feeding losses account for over 10% of the cost of livestock production. This is particularly objectionable because these losses occur after all the time, energy, and effort required to produce and harvest the hay have been incurred. Also, these losses can be greatly reduced or eliminated without a great deal of expense or effort.

**Table 4.** Percent loss of hay from curing through feeding.

	—Lax management—		—Good management—	
	Incremental <sup>a</sup>	Additive <sup>b</sup>	Incremental <sup>a</sup>	Additive <sup>b</sup>
Field curing	25	25	12	12
Harvesting	15	36	8	19
Storage	35	58	5	23
Feeding	30	71	8	29
<b>Total loss</b>	—	<b>71</b>	—	<b>29</b>

<sup>a</sup> Losses of dry matter present at the beginning of a step.

<sup>b</sup> Losses accumulate with each step.

Source: Dr. Mike Collins, University of Kentucky.

# Possible pasture combinations by region

Numerous strategies discussed within this publication can be used to help extend grazing and reduce the number of days stored feed must be provided to livestock. Obviously, some are appropriate only in certain geographical areas or on certain farms within an area, and some are likely to be of much more value in a specific situation than others. No particular set of strategies is appropriate for every producer, even within a given geographical area.

In most areas, exploiting forage growth distribution differences offers much opportunity for extending grazing. Figure 5 illustrates some forage species or categories of species that often work well for producers in selected areas of the nation. The graphs show a few general combinations likely to be used in the Upper Midwest and Northeast, in the Tall Fescue Belt, in the Deep South, and in the Humid Southwest.

Once pasture forage growth distribution has been maximized, other strategies to lower stored feed requirements can be employed. These may include changing the breeding season, selling animals at certain times of the year, use of creative grazing management, or implementing practices to minimize hay waste. Almost anything a livestock producer can do to shave days off the length of time stored feed would otherwise need to be fed will favor increased profitability.

Figure 5. Growth patterns of forage species by region.

### Corn Belt, Upper Midwest, and Northeast

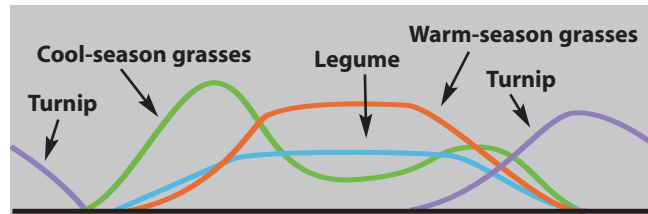

### Tall Fescue Belt

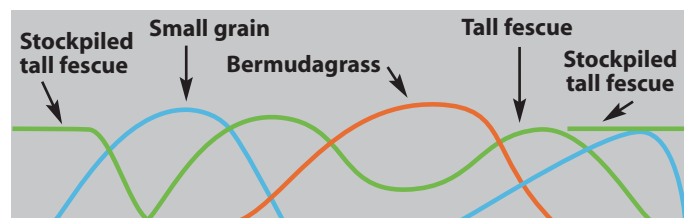

### Deep South

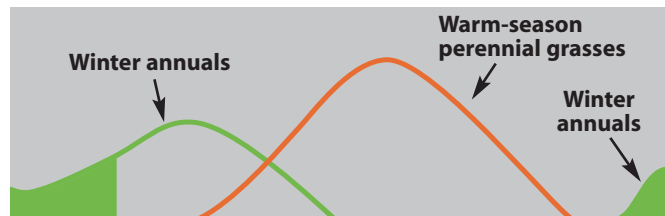

Autumn and winter growth (shaded areas) varies due to several factors including date of planting, species planted, and geographical location.

### Humid Southwest

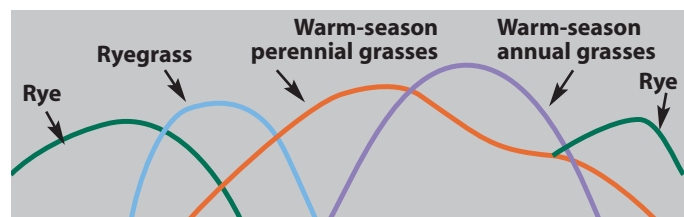

# Ten keys to a profitable forage program

- 1. Remember that you are a forage farmer.** Forage typically accounts for over half the cost of production of forage-consuming animals and provides most of their nutrition. Thus, it has a major influence on both expenses and income. Efficient forage production and utilization are essential to a profitable operation.
- 2. Know forage options, animal nutritional needs, and establishment requirements.** Forages vary as to adaptation, growth distribution, forage quality, yield, and potential uses. Various types and classes of animals have different nutritional needs. Good planting decisions depend on knowing forage options for your land resources and the nutritional needs of your animals.
- 3. Soil test, then lime and fertilize as needed.** This practice, more than any other, affects the level and economic efficiency of forage production. Fertilizing and liming as needed help ensure good yields, improve forage quality, lengthen stand life, and reduce weed problems.
- 4. Use legumes whenever feasible.** Legumes offer important advantages including improved forage quality and biological nitrogen fixation, whether grown alone or with grasses. Once legumes have been established, proper management optimizes benefits.
- 5. Emphasize forage quality.** High animal gains, milk production, and reproductive efficiency require adequate nutrition. Producing high-quality forage necessitates knowing the factors that affect forage quality and using appropriate management. Matching forage quality to animal nutritional needs greatly increases efficiency.
- 6. Prevent or minimize pests and plant-related disorders.** Variety selection, cultural practices, scouting, pesticides, and other management techniques can minimize pest problems. Knowledge of potential animal disorders caused by plants can help avoid them.
- 7. Strive to improve pasture utilization.** The quantity and quality of pasture growth vary over time. Periodic adjustments in stocking rate or use of cross fencing to vary the type or amount of available forage can greatly affect animal performance and pasture species composition. Matching stocking rates with forage production is also extremely important.
- 8. Minimize stored feed requirements.** Stored feed is one of the most expensive aspects of animal production, so lowering requirements reduces costs. Extending the grazing season with use of both cool-season and warm-season forages, stockpiling forage, and grazing crop residues are examples of ways stored feed needs can be reduced.
- 9. Reduce storage and feeding losses.** Wasting hay, silage, or other stored feed is costly. Minimizing waste with good management, forage testing, and ration formulation enhances feeding efficiency, animal performance, and profits.
- 10. It's up to you.** Rarely, if ever, do we get something for nothing. In human endeavors, results are usually highly correlated with investments in terms of thought, time, effort, and a certain amount of money. In particular, the best and most profitable forage programs have had the most thought put into them.

Source: Ball, D.M., C.S. Hoveland, and G.D. Lacefield, 1996. Adapted with permission from the International Plant Nutrition Institute, Norcross, GA.



## **AUTHORS**

### **Dr. Don Ball**

Extension Agronomist/Professor  
Auburn University

### **Ed Ballard**

Animal Systems Educator (ret.)  
University of Illinois Extension

### **Mark Kennedy**

State Grazing Lands Specialist  
USDA/NRCS, Houston, MO

### **Dr. Garry Lacefield**

Extension Agronomist/Professor  
University of Kentucky

### **Dr. Dan Undersander**

Extension Agronomist/Professor  
University of Wisconsin-Madison

## **REVIEWERS**

*The authors gratefully acknowledge reviews of this publication provided by:*

### **James B. Cropper**

USDA/NRCS  
Forage Management Specialist  
Greensboro, NC

### **R.L. Dalrymple**

Agronomist (ret.),  
The Noble Foundation  
Ardmore, OK

### **Dave Forgey**

Forgey's River-View Farm, Inc.  
Logansport, IN

### **Jim Gerrish**

Grazing Lands Consultant,  
American Grazing Lands Services, LLC  
May, ID

### **John L. Merrill**

XXX Ranch, Inc.  
Crowley, TX

### **Leah Miller**

Director, Small Farm Institute  
Coshocton, OH

### **Dr. Jim Russell**

Professor of Animal Sciences  
Iowa State University  
Ames, IA

### **Kimberli R. Stine**

USDA/NRCS  
National GLCI Coordinator  
Fort Worth, TX

### **Dr. Matt R. Sanderson**

USDA/ARS  
Pasture Systems/Watershed  
Management Research Unit  
University Park, PA

**Acknowledgements:** The authors also wish to express their appreciation to the Illinois Grazinglands Conservation Initiative Association, to USDA/NRCS, and to the Missouri Forage and Grassland Council/Grazing Lands Conservation Initiative for providing funds to facilitate development of this publication.

*The USDA/NRCS is an equal opportunity provider and employer.*



Ball, D.M., E.N. Ballard, M.L. Kennedy, G.D. Lacefield, and D.J. Undersander, 2008.  
*Extending Grazing and Reducing Stored Feed Needs.* Grazing Lands Conservation Initiative Publication 8-01, Bryan, TX.



# Use of Goats as Biological Agents for the Control of Unwanted Vegetation

[J-M Luginbuhl](#), [J T Green](#), [M H Poore](#) and [J P Mueller](#)

---

Presented at the International Workshop "Los Arboles en los Sistemas de Producción Ganadera" [ Use of Trees in Animal Production systems], Indio Hatuey Pasture and Forage Experimental Station, Matanzas. November 26-29, 1996.

## ABSTRACT

Much of hill land pasture in the Appalachian region of the United States is weed and brush infested. In addition, over 500,000 ha of forest in the Southeastern region of the country is invaded by kudzu (*Pueraria lobata*). Current weed management and control practices rely heavily on herbicides. Low cost, low input and environmentally acceptable reclamation procedures are needed to maintain these pastures and forest land in production. A field study was initiated at the North Carolina Department of Agriculture Mountain Research Station in Western North Carolina to evaluate the effectiveness of utilizing goats alone (30 mature brush does/ha) or in combination with cattle (17 mature brush does/ha + 2 to 3 steers/ha - 225 kg live weight) to renovate overgrown mountain pastures and to control multiflora rose (*Rosa multiflora Thunb.*) bushes. Over four grazing seasons, managed defoliation with goats alone or goats with cattle resulted in a substantial increase in vegetative cover (goats: 65 to 86%; goats + cattle: 65 to 80%) by favorable grass and legume species (goats: 16 to 63%; goats + cattle: 13 to 54%) while vegetative cover decreased from 70 to 22% in the control plot. Multiflora rose bushes were practically eliminated over the 4-year period in both the goat (100%) or goat + cattle (92%) treatments. In another field study conducted at the North Carolina State University research farm in Raleigh, growing buck kids (initial live weight: 17.3 kg) were stocked at the rate of 18 or 29 animals per hectare and rotationally grazed on 12 kudzu plots for 49 and 31 days, respectively. Daily gain and gain/ha for the grazing period averaged 60 and 88 g/day and 54.4 and 78.8 kg/ha, respectively. These results indicate that goats may be a viable management tool for the control of unwanted vegetation.

## RESUMEN

**Uso de cabras como agentes biológicos para el control de vegetación indeseable.** Gran parte de las pasturas de ladera en la región de las montañas Apalaches en Estados Unidos está infestada por malezas y arbustos. Adicionalmente, más de 500,000 ha de tierras forestales en la región sudeste del país están invadidas por kudzú (*Pueraria lobata*). Las labores de control y manejo de malezas actualmente usadas se basan principalmente en el uso de herbicidas. Prácticas de recuperación de bajo costo, bajo insumos y ecológicamente aceptables son necesarias para mantener esas pasturas en producción. Un estudio fue iniciado en la Estación Experimental de las Montañas del Departamento de Agricultura de Carolina del Norte para evaluar la efectividad de utilizar cabras solas (30 cabras mestizas/ha) o en combinación con ganado vacuno (17 cabras/ha + 2 o 3 novillos/ha - 225 kg de peso vivo) en la renovación de pasturas sobrecrecidas y en el control de arbustos de rosa (*Rosa multiflora Thunb.*). En cuatro años de pastoreo, la defoliación manejada con cabras solas o en combinación con novillos resultó en un incremento sustancial en la cobertura vegetativa (cabras solas: 65 a 86%; cabras + novillos: 65 a 80%) con especies de gramíneas y leguminosas favorables (cabras solas: 16 a 63%; cabras + novillos: 13 a 63%) mientras que la cobertura vegetativa en el control disminuyó de 70 a 22%. Los arbustos de rosa fueron prácticamente eliminados después de un período de 4 años en los tratamientos con cabras solas (100%) y cabras combinadas con novillos (92%). En otro estudio conducido en la finca experimental de la Universidad Estatal de Carolina del Norte en Raleigh, caprinos machos jóvenes (peso inicial: 17.3 kg) pastorearon 12 parcelas de kudzú por 49 y 31 días a una carga equivalente a 19 y 29 animales/ha respectivamente. La ganancia diaria de peso vivo y la ganancia de peso/ha en el período de pastoreo promedió entre 60 a 88 g/día y 54.4 a 78.8 kg/ha para las cargas de 19 y 29 animales/ha respectivamente. Estos resultados indican que las cabras pueden ser una herramienta viable de manejo para el control de vegetación indeseable.

---

## INTRODUCTION

In the Southeastern United States, goats are becoming increasingly important contributors to the income of many producers. In addition, the role of goats as biological control agents is becoming ever more important due to environmental concerns and elevated costs of other control methods such as mechanical cutting and herbicide application (Magadella et al., 1995). There is also a need to evaluate forages and forage systems for goats that are integrated with existing cattle operations. It is estimated that most beef cattle farmers would have enough "excess" feed in cattle pastures to feed 1-2 goats per cow with no additional feed input. The complementary effects of grazing cattle and goats on the same farm provide an opportunity to enhance and augment the existing beef cattle industry by improving pasture condition and feed quality. The purpose of this paper is to describe research results with potential for the development of practical feeding systems for meat goats.

## GRAZING STUDIES

**Biological Control of Weeds and Brush.** Much of hill-land pasture in Western North Carolina is brush infested. Low cost and low input reclamation procedures are needed to provide owners with ways to maintain these pastures in production. In a demonstration conducted at the NC Department of Agriculture Research Station located in Waynesville at approximately 35.50 N lat. and 83.00 W long., brush goats were grazed alone (30 mature does/ha) or with cattle (17 mature does/ha with 2 to 3, 225 kg steer/ha for 4 years in a 2.4 ha apple orchard left untouched for 15 years. The orchard was divided into five sections consisting in a control paddock, two replicated paddocks grazed by goats alone and two replicated paddocks grazed by goats + cattle. Grazing occurred for 45 to 60 days from May to July and for another 24 to 35 days in September and October. The grazing/browsing periods were determined by available forage. The botanical composition of the grazing site was primarily herbaceous weeds such as brambles (*Rubus spp.*), honeysuckle (*Lonicera japonica*), chickweed (*Stellaria spp. L.*), thistle (*Cirsium spp.*), multiflora rose (*Rosa multiflora Thunb.*) and hardwood saplings with some grass and clover. Over the four grazing seasons, the vegetative cover increased from 65% in May 1991 to 86% in October 1994 in the goat pasture, and from 65 to 80% in the goat + cattle pasture (Table 1). In addition, the cover from favorable grasses and legumes increased from 16 to 63% and from 13 to 54% in the goat and goat + cattle pastures, respectively. Vegetative cover in the control plot declined from 70% in May 1991 to 22% in October 1994, with the cover from grasses and legumes ranging from 10 to 27%. The shift in botanical composition in the grazed plots was attributed to the preference of goats and to a lesser extent of cattle for the broadleaf species, which allowed favorable grasses and legumes to be more competitive. Goats and goats + cattle were also very effective in controlling multiflora roses. Individual multiflora rose bushes were identified and marked to determine the effects of browsing on plant survival. Multiflora rose bushes were practically controlled after four grazing seasons, as shown by their reduced height and the number of dead canes (Table 2). However, large quantities of new shoots have sprouted on the pasture following two years of rest, indicating that some roots were still viable and that multiflora roses bushes are difficult to eliminate permanently. Another experiment was subsequently started in spring 1996. The experimental area of the orchard was expanded and divided into nine sections consisting of three control paddocks, three replicated paddocks grazed by goats + cattle (6 growing Angus steers and 9 adult Boer and crossbred Boer bucks) and three replicated paddocks grazed by cattle alone (6 growing Angus steers). Animals were rotationally grazed among the paddocks from April to October. Animal performance and the survival of black locust (*Robinia pseudoacacia*), an indigenous leguminous tree invading the experimental plots, are being monitored in addition to the measurements taken during the previous experiment.

**Biological Control of Kudzu.** Kudzu (*Pueraria lobata*) is one of the most aggressive legume vine growing in the Southeastern United States (Bonsi et al., 1991). Herbicides have been used to control kudzu, but these chemicals are expensive and repeated applications are usually required. In addition, environmental concerns associated with the repeated use of chemicals cannot be over emphasized. A preliminary experiment conducted at the North Carolina State University research farm located in Raleigh, at approximately 35.75 N lat. And 78.75 W long., was designed to examine whether or not brush goats might thrive while controlling this unwanted plant. In July and August 1993, 16 growing bucks and wethers of a non-descript breed (initial live weight: 22 kg) were continuously grazed on kudzu for 49 and 26 days at a rate of either 59 or 99 head/ha, respectively. Animals on the low stocking rate gained 25 g/d compared to a loss of 26 g/day for animals stocked at 99 head/ha. The following year, 12 growing bucks of a non-descript breed (initial live weight: 17.3 kg) were rotationally grazed on 12 kudzu plots for 49 and 31 days at a rate of either 18.5 or 28.9 animals/ha (Table 3). Animals on the high stocking rate were grazed for a shorter period because of lack of adequate regrowth. The experimental design was a randomized complete block with 2 replications. Shrunken live weights were determined at the start and completion of the experiment by withdrawing feed and water overnight from

the animals. Animals gained 60 and 88 g/day, respectively, resulting in 52.9 and 78.3 kg gain/ha for the length of the grazing period. These results indicate that goats might offer a viable alternative to achieve management and control of this unwanted plant while providing additional income to goat farmers.

## CONCLUSIONS

The foraging habits of goats have important environmental implications by ultimately increasing the sustainability of integrated production systems and at the same time providing an additional source of income to producers. However, the above findings warrant further investigation.

## REFERENCES

Bonsi, C., E. Rhoden, A. Woldeghebriel, P. Mount, S. Solaiman, R. Noble and G. Paris. 1991. Kudzu-goat interactions - A pilot study. In: S. G. Solaiman and W. A. Hill (Ed.) Using Goats to Manage Forest Vegetation: A Regional Inquiry. p 84.

Magadla, A. M., M. E. Dabaan, W. B. Bryan, E. C. Prigge, J. G. Skousen, G. E. D'Souza, B. L. Arbogast and G. Flores. 1995. Brush clearing on hill land pasture with sheep and goats. *J. Agron. & Crop Sci.* 174:1.

**Table 1. Effect of grazing on total soil vegetative cover and percent vegetation as grass over four grazing seasons**

Item, %	May 1991			October 1994		
	Control	Goats	Goats/Cattle	Control	Goats	Goats/Cattle
Vegetative cover	70	65	65	22	86	80
Cover as grass	10	16	13	27	63	54

**Table 2. Effect of grazing goats and goats/cattle on survival of multiflora rose bushes over four grazing seasons**

Item, %	May 1991			October 1994		
	Control	Goats	Goats/Cattle	Control	Goats	Goats/Cattle
<b>Characteristic of multiflora rose bush</b>						
Height, m	2.7	2.1	2.1	2.0	.4	.7
Dead canes, %	0	0	0	0	100	92

**Table 3. Performance of buck kids grazing kudzu - 1994**

Item	Treatment 1	Treatment 2
Duration, d	49	31
Stocking rate, head/ha	18.5	28.9
Intitial wt, kg	17.3	17.2

<b>Final wt, kg</b>	20.3	20.0
<b>Daily gain, g</b>	60	88
<b>Gain/ha, kg</b>	54.4	78.8

---

Return to [EAH Meat Goats Home](#)

Return to [Extension Animal Husbandry Home](#)

Return to [Department of Animal Science Home](#)

---

*Last modified October 1998*

*[EAH Webmaster](#), Department of Animal Science, NCSU*

---

# Forage Needs for Meat Goats and Sheep

[J-M Luginbuhl](#), [J T Green](#), [J P Mueller](#) and [M H Poore](#)

---

*In: "Production and Utilization of Pastures and Forages" - Technical Bulletin 305  
North Carolina Agricultural Research Service, North Carolina State University, Raleigh*

---

## FORAGES FOR GOATS

Goats offer an alternative to utilizing forage and vegetation which is otherwise "wasted", while producing products (milk, meat and fiber) which are currently marketable and in demand by a growing segment of the US population. In addition, goats offer the potential for biological control of unwanted vegetation in pastures and forests, which will reduce dependence on certain pesticides.

Goats consume only the best parts of a wide range of grasses, legumes, and browse plants. Browse plants include brambles, shrubs, trees, and vines with woody stems. The quality of feed on offer will depend on many things, but it is usually most directly related to the age or stage of growth at the time of grazing. The nutrient composition for several common feed types found on many farms is shown in [Table 1](#).

## GRAZING BEHAVIOR

Goats are very active foragers, able to cover a wide area in search of scarce plant materials. Their small mouths and split upper lips enable them to pick small leaves, flowers, fruits and other plant parts, thus choosing only the most nutritious available feed.

The ability to utilize browse species, which often have thorns and small leaves tucked among woody stems and an upright growth habit, is a unique characteristic of the goat compared to heavier, less agile ruminants. Goats have been observed to stand on their hind legs and stretch up to browse tree leaves or throw their bodies against saplings to bring the tops within reach.

The feeding strategy of goats appears to be to select grasses when the protein content and digestibility are high, but to switch to browse when the latter overall nutritive value may be higher. This ability is best utilized under conditions where there is a broad range in the digestibility of the available feeds, giving an advantage to an animal which is able to select highly digestible parts and reject those materials which are low in quality.

Grazing goats have been observed to:

- select grass over clover.
- prefer browse over grazing.
- prefer foraging on rough and steep land over flat, smooth land.
- graze along fence lines before grazing the center of a pasture.
- graze the top of pasture canopy fairly uniformly before grazing close to the soil level.

Because of their inquisitive nature and tolerance of "bitter" or high tannin material goats may eat unpalatable weeds and wild shrubs that may be poisonous, such as cherry or milkweed. The absence or the severity of poisoning is related to the quantity of material consumed, the portion and age of the plant eaten, the season of the year, the age and size of the animal, and a multitude of other factors. In addition, several ornamental plants that are grown outdoors or indoors are highly toxic. For example, goats should not have access to, or be fed clippings of yew, azaleas, delphinium, lily-of-the-valley and larkspur.

In a pasture situation goats are "top down" grazers. This behavior results in uniform grazing and favors a first grazer-

last grazer system using a goat flock as the first group and cattle as the last group. This management is most appropriate with lactating does or growing kids.

Goats naturally seek shelter when it is available, and do not like to get wet. Goats seem to be less tolerant of wet cold conditions than sheep and cattle because of a thinner fat layer. A wet goat can easily become sick. Therefore, it is usually necessary to provide artificial shelters, such as open sheds.

## **NUTRIENT REQUIREMENTS**

The goat is not able to digest the cell walls of plants as well as the cow because feed stays in their rumen for a shorter time period. A distinction as to what is meant by "poor quality roughage" is necessary in order to make decisions concerning which animal can best utilize a particular forage. Trees and shrubs, which represent poor quality roughage sources for cattle, because of their highly lignified stems and bitter taste, may be adequate in quality for goats, which may avoid eating the stems, don't mind the taste and benefit from the relatively high levels of protein and cell solubles in the leaves of these plants. On the other hand, straw, which is of poor quality due to high cell wall and low protein, can be used by cattle but will not provide even maintenance needs for goats because goats utilize the cell wall even less.

Goats must consume a more concentrated diet than cattle because their digestive tract size is smaller relative to their maintenance energy needs. When the density of high quality forage is low and the stocking rates are low, goats will still perform well because of their grazing behavior, even though their nutrient requirements exceed those of most domesticated ruminant species. Total digestible nutrients (TDN) and protein requirements are given in [Table 2](#). Comparing the nutrient requirements to the chemical composition of feeds shown in [Table 1](#) should give producers an idea of how to match needs with appropriate forages. For comparison, low quality forages have 40 to 55% TDN, good quality forages have from 55 to 70% TDN, and concentrates have from 70 to 90% TDN.

High quality forage and/or browse should be available to does during the last month of gestation and to lactating does, to developing/breeding bucks, and to weanlings and yearlings. Female kids needed for reproduction should be grazed with their mothers during as much of the milk feeding period as possible and not weaned early. When the quantity of available forage and/or browse is limited or is of low quality, a concentrate supplement may be considered to maintain desired body condition, depending on cost:benefit. Whole cottonseed makes an excellent supplement for goats when fed at no more than 0.5 lb/head/day. Dry does and non-breeding mature bucks will meet their nutritional requirements on low to medium quality forage (10-12% protein and 50-60% TDN).

A complete goat mineral or a 50:50 mix of trace mineralized salt and dicalcium phosphate should be offered free choice during the first 90 days of lactation in herds with a controlled breeding season (or year round for those without controlled breeding) and for young goats. Selenium is marginal to deficient in all areas of North Carolina. Therefore, trace mineralized salt or complete minerals containing selenium should always be provided to the goat herd year around. It is sometimes advisable to provide a mineral mix that contains 20-25% magnesium oxide to reduce the risk of grass tetany when heavy milking goats are grazing lush small grain or grass/legume pastures in early lactation.

## **FORAGES FOR SHEEP**

Profitable lamb production is highly dependent upon efficient production and use of forage crops. Harvesting of the forage crops by the sheep themselves, with as little supplemental feeding as possible, is the most practical and economical means to ensure the success of a sheep operation. Because feed costs usually amount to 50 to 70% of the total cost of producing sheep, it is essential to develop an economical year round forage supply.

The entire Appalachian mountain chain, extending from Maine south into Alabama, is a region dominated by a mixture of Kentucky bluegrass and intermediate white clover. This region has potential for lamb production with little competition to the existing beef industry. By using good pastures (fescue/orchardgrass/bluegrass - clover or alfalfa), crop residues, waste land forage, hay and silage, it is possible to raise sheep economically in many livestock programs.

## **GRAZING BEHAVIOR**

Sheep are selective grazers, choosing plant parts which are of higher quality (and more digestible) than cattle when both species have access to the same herbage. Therefore, when grazed alone, sheep should be stocked heavily to avoid too much trampling and soiling of the ungrazed forage. As a general rule, sheep eat more browse than cattle, but less than goats, because sheep are not nearly as selective as goats. Sheep also make better use of rough, steep hill pastures than cattle or goats.

## NUTRIENT REQUIREMENTS

### Ewes

The nutritional needs of ewes for maintenance and the first 15 weeks of gestation are relatively low. Most can be furnished by medium to low quality forage. However, nutritional needs increase about 1.5 times their maintenance needs during the last 4 to 6 weeks of gestation, and good pasture must be available or additional grain must be fed during this period. Nutritional needs increase to 3 times maintenance during the first eight weeks of lactation, and decrease to 2 times maintenance by the third month of lactation ([Table 3](#)). If the ewe is nursing twins, she will need 15% more digestible nutrients than for one lamb. Ewes with two or more lambs should be separated from the flock and given extra feed. After weaning, the ewes go back to maintenance level, until flushing. The forage and supplemental feed program should be designed to fit these nutritional cycles, the lambing period, and the cost:benefit structure.

During maintenance periods, ewes can be used to clean up paddocks after lambs or other livestock. Be careful that ewes aren't kept on poor quality forage for too long, or a reduced number of lambs may be born the next spring.

It is better to alternate a day of grazing low quality pasture with a day of grazing higher quality pasture. Grazing ewes on forage that is better than their minimal needs will result in them weighing more and consistently giving birth to more and larger lambs that gain weight faster, but can also be associated with lambing difficulties.

### Lambs

Pastures for lambs should be of very high quality because of their nutritional requirements ([Table 4](#)). Forward grazing is a management technique enabling the lambs to have access to the best quality forage. If a high quality forage is not available for the entire flock, the lambs can be creep grazed on adjacent pastures. Fast rates of gain cannot be achieved with low quality pasture, because the bulk of feed in the rumen will limit the intake by the lambs before enough energy has been ingested to meet their nutritional requirements.

Lambs will consume approximately 2 to 4% of their body weight in dry matter daily. Most immature, leafy grazable forages will contain about 80 to 85% water. Therefore, lambs will consume from 10 to 20 lbs of green forage daily, depending upon their body weight. The daily performance of lambs is generally improved by the addition of a legume to a cool-season grass pasture. Sheep have shown to clearly prefer clover when it is readily available. Suckling lambs have shown average daily gains of 0.4 lb when grazing orchardgrass pastures compared with 0.6 lb from an orchardgrass-ladino clover mixture. Data from New Zealand have shown an 18% increase in gain by sheep grazing a perennial ryegrass-ladino clover mixture compared with sheep grazing a pure stand of perennial ryegrass. Weaned lambs grazing alfalfa have had daily gains of 0.3 to 0.45 lb, even during summer months.

Pure stands of annual or perennial grasses can increase the incidence of grass tetany, especially in the early spring. This can be controlled by providing a mineral mix that contains 20-25% magnesium oxide. Legumes will reduce the risk of grass tetany because of their high magnesium content. It is most convenient to use a complete commercially prepared sheep and goat mineral which will provide selenium and other minerals plus phosphorous, salt and magnesium. **Never use cattle minerals because a good cattle mineral will kill sheep due to its copper content!**

## GRAZING MANAGEMENT FOR GOATS AND SHEEP

Grazing of forage generally provides the least expensive way of supplying nutrients to the animals. Therefore, it is essential to develop a year round forage program which allows for as much grazing as possible every month of the year. The principles of controlled grazing of goats or sheep are similar to those used for cattle. The primary goal is to have enough control of the animal's grazing pattern one can dictate the amount of defoliation and the frequency of

defoliation. However, good pasture management involves much more than simply turning the animals to pasture. To obtain efficient animal production over a number of years, the needs of the plants as well as the needs of the animals must be taken into consideration. The development of a successful forage systems/grazing management entails:

1. Adjusting the number of animals grazing a certain area (stocking density) of pasture because some forage must be left at the end of the grazing period to maintain adequate plant production. Otherwise, overuse will weaken the plants and regrowth will be slower. Adjusting the stocking rate requires experience because forage growth is not uniform throughout the year or from year to year.
2. Harvesting ungrazed forages as hay or silage at an immature stage of growth when forage growth is more rapid than it can be grazed in order to provide high quality feed when grazing is not available. Cross fencing will keep animals concentrated on small areas while excess growth accumulate on other paddocks. Under those circumstances, short duration rotational grazing through a series of paddocks, or strip grazing a rapidly growing pasture by allowing animals access to only enough forage to carry them for one day using a movable fence, are alternatives to consider.
3. Overseeding bermuda pastures with legumes, ryegrass, small grains, or brassicas to extend the grazing season and to provide some high quality feed during the winter and spring.
4. When in short supply, restricting the use of high quality forage for the supplementation of other low quality pastures, hay or silage. This can be achieved by letting goats or sheep graze high quality forage a few hours at the end of each day, or by grazing the limited high quality supply every other day.

When the aim is to kill or reduce the amount of unwanted vegetation, then the severity and frequency of grazing is much greater. Goats will actively select major weeds at particular stages of growth. As a rule, effective control of unwanted vegetation can be achieved in two years. Therefore, the advantages of the goat in feeding strategy must be weighed against its disadvantages. Being a browsing animal, the goat stunts tree growth and prevents the regeneration of forests and thus should be managed closely in areas desired for forests. Goats could be very useful, however, in areas where regrowth of brush and trees is not desirable.

## GRAZING TIME

Some livestock producers confine their animals at night for protection from straying or predation. However, confinement means that grazing time is reduced and that the animals spend more time in unsanitary lots or pens. Reduced grazing time due to confinement at night is even more critical during the hot and humid summer months, because animals may not forage efficiently during the hottest periods of the day. If animals must be confined at night, allowing the animals to graze during the cooler parts of the day would increase production as a consequence of improved feed intake resulting from increased grazing time.

## FENCING FOR GOATS AND SHEEP

Goats and sheep can be controlled with 4-5 strands of smooth **electrified wire**. The wire spacings vary from 6 to 8 inches near the ground to 8 to 12 inches for the top strands. Perimeter fence height should be at least 42 inches tall. A high wire, or an offset wire set one foot inside the fence near the top, may be needed if goat jumping is a problem. As a rule, goats crawl rather than jump, so the bottom wire should be kept close to the ground. A grounded barb wire laid along the ground will help with predator control, especially in mountainous areas. Training animals to respect electric wire can be done effectively by forcing animals to stay in a small paddock which encourages them to "test" the wire.

**Woven wire** is effective, but costs at least twice that of a 5 strands electric fence and horned goats frequently get caught. To address this problem with existing fences, an electric wire offset about 9 inches from the woven wire fence and about 12 to 15 inches from the ground will reduce the number of animals caught in the woven wire fence. However, this practice also reduces control of forage growth on the fence line. Dehorning goats will eliminate this problem.

Boundary fences should control all stock at all times. However, interior fences may be made of 3 to 4 wires, assuming animals are well trained. Because goats like to climb, the corners of fences should not have the diagonal bracing for posts or the animals will climb out of the pasture. Corner posts should be driven with a deadman or H-braces.



## GRAZING AND STOCKING RATES

The differences in feeding behavior among cattle, sheep and goats uniquely fit each species to the utilization of different feeds available on a farm. These differences should be considered in determining the best animal species to utilize a particular feed resource. Feeding behavior is also important in determining whether single or multi-species will best utilize available plant materials. Most studies indicate greater production and better pasture utilization are achieved when sheep and cattle or sheep, cattle and goats are grazed together as opposed to grazing only sheep or goats or cattle alone. This is especially true where a diverse plant population exists.

Under mixed grazing conditions (more than one ruminant species grazing in the same paddock) on fescue/orchardgrass-clover where the forage supply is low and the nutritive value is high, goats and sheep may be at a disadvantage. Under those conditions, the animal with the largest mouth (cattle, horse) has an advantage because it can grasp more material per unit of time. In addition, food intake by goats is rapidly reduced and may stop if the pasture is soiled or trampled, even with an ample amount of pasture remaining.

Generally one cow eats about the same amount of feed as 6 to 8 goats ([Table 4](#)). Because of the complimentary grazing habits, the differential preferences and the wide variation in vegetation within most pastures, one to two goats could be grazed with every beef cow in NC without adversely affecting the feed supply of the beef herd. The selective grazing habits of goats in combination with cattle would eventually produce pastures which would be more productive, of higher quality, and with little weed problems as a result of the mixed grazing.

In grass-legume mixtures cattle will generally graze the grass species more readily than sheep, which will prefer legumes and other broadleaf species. As a rule of thumb five to six ewes and their lambs will consume similar amounts of feed as one cow and her calf. Therefore, if the area available for grazing usually carries one cow-calf pair, five to six ewes and their lambs can safely graze on the same area ([Table 4](#)).

## MANAGEMENT OF REPRODUCTION

Goats are known as seasonal breeders, which means the female only cycles and accepts the male during times of shortening daylength. Cycling usually initiates by the end of August to early September through February. If not bred, does will cycle every 21 days, similar to cows. Therefore, does should become pregnant within four weeks following the introduction of bucks with the does. The gestation length (time from breeding to kidding) averages 150 days (5 months).

Yearling goat kids may be bred in the first year at 7-10 months of age, depending on breed, if they have grown well and are of good size and condition. Body weight, relative to breed is more important than age and can influence lifetime performance. The doe kid may be able to reproduce at 3-4 months of age but should not be allowed to do so, as her growth may be permanently stunted. To prevent this, buck kids should be separated from doe kids at an early age (about 4 months). If breeding of doe kids is postponed much beyond 10 months of age, they will be less productive.

---

Return to [EAH Meat Goats Home](#)

Return to [Extension Animal Husbandry Home](#)

Return to [Department of Animal Science Home](#)

---

*Last modified October 1998*

*[EAH Webmaster](#), Department of Animal Science, NCSU*

---

# Forage Needs for Meat Goats and Sheep

Table 1

TABLE 1. ESTIMATED NUTRIENT COMPOSITION OF VARIOUS FEEDS <sup>1</sup>		
PLANT TYPE	TDN, %	CRUDE PROTEIN, %
Whole cottonseed	88	22
Corn	86	9
Soybean meal (48%)	82	44
Pasture, vegetative	60-76	12-24
Pasture, mature	50-60	8-10
Pasture, dead leaves	35-45	5-7
Fescue hay, 6 weeks growth	58-62	8-11
Fescue hay, 9 weeks growth	48-53	7-9
Bermuda hay, 7 weeks growth	54-58	9-11
Bermuda hay, 12 weeks growth	47-50	7-9
Alfalfa hay	50-63	13-20
Honeysuckle, leaves+buds	70+	16+
Honeysuckle, mature	68+	10+
Sumac, early vegetative	77	14
Oak, buds and young leaves	64	18
Persimmon leaves	54	12
Hackberry, mature	40	14
Kudzu, early hay	55	14
Juniper	64	6
Acorns, fresh	47	5

<sup>1</sup> Nutrient requirements of Goats in Temperate and Tropical Countries. 1981. National Research Council.

Return to [Forage Needs for Meat Goats and Sheep](#)

Return to [EAH Meat Goats Home](#)

Return to [Extension Animal Husbandry Home](#)

Return to [Department of Animal Science Home](#)

Last modified May 1998

[EAH Webmaster](#), Department of Animal Science, NCSU

[http://www.cals.ncsu.edu/an\\_sci/extension/animal/meatgoat/table1-97.htm](http://www.cals.ncsu.edu/an_sci/extension/animal/meatgoat/table1-97.htm)

Accessed 5/20/10

# Forage Needs for Meat Goats and Sheep

## Table 2

Table 2. Nutrient Requirements for Meat and Fiber Producing Goats <sup>1,2</sup>						
NUTRIENT	YOUNG GOATS <sup>3</sup>		DOES (80 lb)			BUCK (80-120 lb)
	Weanling (30 lb)	Yearling (60 lb)	Dry (Pregnant)	Lactating		
				Avg Milk	High Milk	
Daily Feed, lb	2.0	3.0	4.5	4.5	5.0	5.0
TDN, %	68	65	60	60	65	60
Protein, %	14	12	10	11	14	11
Calcium, %	.6	.4	.4	.4	.6	.4
Phosphorus, %	.3	.2	.2	.2	.3	.2
<sup>1</sup> Nutrient Requirements of Goats. 1981. National Research Council						
<sup>2</sup> Pinkerton, F. 1989. Feeding Programs for Angora Goats. Bulletin 605. Langston University, OK						
<sup>3</sup> Expected weight gain >.44 lb / day						

Return to [Forage Needs for Meat Goats and Sheep](#)

Return to [EAH Meat Goats Home](#)

Return to [Extension Animal Husbandry Home](#)

Return to [Department of Animal Science Home](#)

*Last modified October 1998*

*[EAH Webmaster](#), Department of Animal Science, NCSU*

# Forage Needs for Meat Goats and Sheep

## Table 3

<b>Table 3. Nutrient Requirements for Sheep <sup>1</sup></b>							
<b>Item</b>	<b>Body Weight</b>	<b>Daily Gain or Loss</b>	<b>Daily Intake</b>	<b>TDN</b>	<b>Protein</b>	<b>Ca</b>	<b>P</b>
	<b>lb.</b>			<b>%</b>			
Mature ewes, maintenance	154	.02	2.6	55	9.5	.21	.20
Mature ewes, gestation, last 4 weeks	154	.4	4.0	60	10.6	.34	.31
Mature ewes, lactating, suckling singles	154	-.06	5.5	65	13.3	.37	.28
Mature ewes, lactating, suckling twins	154	-.13	6.2	65	15.0	.39	.29
Finishing lambs	88	.6	3.5	75	11.6	.41	.21
Replacement ram lambs	132	.7	5.3	65	11.0	.35	.18
Replacement ewe lambs	110	.26	3.3	60	9.1	.32	.16
<sup>1</sup> Nutrient Requirements of Sheep. 1985. National Research Council.							

Return to [Forage Needs for Meat Goats and Sheep](#)

Return to [EAH Meat Goats Home](#)

Return to [Extension Animal Husbandry Home](#)

Return to [Department of Animal Science Home](#)

*Last modified October 1998*

*[EAH Webmaster](#), Department of Animal Science, NCSU*

# Forage Needs for Meat Goats and Sheep

## Table 4

<b>Table 4. Estimated Stocking Rates or Feed Needs for Goats, Sheep and Cattle on Pasture</b>			
<b>Pasture Type</b>	<b>Goats</b>	<b>Sheep</b>	<b>Cow</b>
	<b>Head <sup>1</sup></b>		
Good quality pasture system	6-8	5-6	1
Good brush-browse system	9-11	6-7	1
	<b>Head/acre</b>		
Wheat/alfalfa system	10-12	8-9	1.5
Alfalfa pasture, Oklahoma	12-15	10-11	1.9
<sup>1</sup> Number of animals to consume similar amount of feed.			

Return to [Forage Needs for Meat Goats and Sheep](#)

Return to [EAH Meat Goats Home](#)

Return to [Extension Animal Husbandry Home](#)

Return to [Department of Animal Science Home](#)

*Last modified October 1998*

*[EAH Webmaster](#), Department of Animal Science, NCSU*

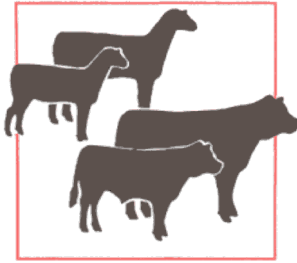

# ANIMAL SCIENCE FACTS

PUBLICATION NUMBER

ANS 00-604MG

## Extension Animal Husbandry

Department of Animal Science

### FORAGE NEEDS AND GRAZING MANAGEMENT FOR MEAT GOATS IN THE HUMID SOUTHEAST

**Jean-Marie Luginbuhl**  
*Extension Meat Goat Specialist*

**Matthew H. Poore**  
*Extension Animal Husbandry Specialist*

**J. Paul Mueller**  
*Extension Pastures & Forage Systems Specialist*

**James T. Green, Jr.**  
*Extension Pastures & Forage Systems Specialist*

#### Forages For Goats

Goats offer an opportunity to more effectively convert pasture nutrients to animal products as milk, meat and fiber which are currently marketable and in demand by a growing segment of the US population. In addition, goats selectively graze unwanted vegetation in pastures and forests, thus providing biological control which will reduce dependence on certain pesticides.

Goats consume only the most nutritious parts of a wide range of grasses, legumes, and browse plants. Browse plants include brambles, shrubs, trees, and vines with woody stems. The quality of feed on offer will depend on many things, but it is usually most directly related to the age or

stage of growth at the time of grazing. The nutrient composition for several common feed types found on many farms is shown in Table 1.

#### Grazing Behavior

Goats are very active foragers, able to cover a wide area in search of scarce plant materials. Their small mouths and split upper lips enable them to pick small leaves, flowers, fruits and other plant parts, thus choosing only the most nutritious available feed.

The ability to utilize browse species, which often have thorns and an upright growth habit with small leaves tucked among woody stems, is a unique characteristic of the goat compared to heavier, less agile ruminants. Goats have been observed to stand on their hind legs and stretch up to browse tree leaves or throw their bodies against saplings to bring the tops within reach.

The feeding strategy of goats appears to be to select grasses when the protein content and digestibility are high, but to switch to browse when the latter overall nutritive value may be higher. This ability is best utilized under conditions where there is a broad range in the digestibility of the available feeds, giving an advantage to an animal which is able to select highly digestible parts and reject those materials which are low in quality.

Grazing goats have been observed to:

- select grass over clover.
- prefer browsing over grazing pastures

*Reviewed by: Douglas S. Chamblee and Joseph C. Burns, Department of Crop Science, North Carolina State University*

Distributed in furtherance of the Acts of Congress of May 8 and June 30, 1914. Employment and program opportunities are offered to all people regardless of race, color, national origin, sex, age, or handicap. North Carolina State University, North Carolina A&T State University, U.S. Department of Agriculture, and local governments cooperating.



**North Carolina  
Cooperative Extension Service**

NORTH CAROLINA STATE UNIVERSITY  
COLLEGE OF AGRICULTURE & LIFE SCIENCES

- prefer foraging on rough and steep land over flat, smooth land.
- graze along fence lines before grazing the center of a pasture.
- graze the top of pasture canopy fairly uniformly before grazing close to the soil level.

Because of their inquisitive nature and tolerance of "bitter" or high tannin material, goats may eat unpalatable weeds and wild shrubs that may be poisonous, such as cherry or milkweed. The absence or the severity of poisoning is related to the quantity of material consumed, the portion and age of the plant eaten, the season of the year, the age and size of the animal, and other factors. In addition, several ornamental plants that are grown outdoors or indoors are highly toxic. For example, goats should not have access to, or be fed clippings of yew, azaleas, delphinium, lily-of-the-valley and larkspur.

In a pasture situation goats are "top down" grazers. This behavior results in uniform grazing and favors a first grazer-last grazer system. This might consist of using a goat herd as the first group and cattle as the last group. This management is most appropriate with lactating does or growing kids.

Goats naturally seek shelter when it is available. Goats seem to be less tolerant of wet cold conditions than sheep and cattle because of a thinner subcutaneous fat layer. A wet goat can easily become sick. Therefore, it is advisable to provide artificial shelters, such as open sheds.

### **Nutrient Requirements**

The goat is not able to digest the cell walls of plants as well as the cow because feed stays in their gastrointestinal tract for a shorter time period. A distinction as to what is meant by "poor quality roughage" is necessary in order to make decisions concerning which animal can best utilize a particular forage. Trees and shrubs, which represent poor quality roughage sources for cattle, because of their highly lignified stems and bitter taste, may be adequate in quality for goats. Goats will avoid eating the stems, but don't mind the taste and will benefit from the relatively high levels of protein and cell solubles in the leaves of these plants. On the other hand, straw, which is of poor quality due to high cell

wall and low protein, can be used by cattle but will not provide maintenance needs for goats because goats utilize the cell wall even less than cattle.

Goats must consume a more concentrated diet than cattle because their digestive tract size is smaller relative to their maintenance energy needs. When the density of high quality forage is low and the stocking rate is low, goats will still perform well because of their grazing behavior, even though their nutrient requirements exceed those of most domesticated ruminant species. Total digestible nutrients (TDN) and protein requirements are given in Table 2. Comparing the nutrient requirements to the chemical composition of feeds shown in Table 1 should give producers an idea of how to match needs with appropriate forages. For comparison, low quality forages have 40 to 55% TDN, good quality forages have from 55 to 70% TDN, and concentrates have from 70 to 90% TDN.

High quality forage and/or browse should be available to does during the last month of gestation and to lactating does, to developing/breeding bucks, and to weanlings and yearlings. Female kids needed for reproduction should be grazed with their mothers during as much of the milk feeding period as possible and not weaned early. When the quantity of available forage and/or browse is limited or is of low quality, a concentrate supplement may be considered to maintain desired body condition, depending on cost:benefit. Whole cottonseed makes an excellent supplement for goats when fed at no more than 0.5 lb/head/day. Dry does and non-breeding mature bucks will meet their nutritional requirements on low to medium quality forage (10-12% protein and 50-60% TDN).

Providing free choice a complete goat mineral or a 50:50 mix of trace mineralized salt and dicalcium phosphate is advisable under most situations. Selenium is marginal to deficient in all areas of North Carolina. Therefore, trace mineralized salt or a complete mineral mix containing selenium should always be provided to the goat herd year around. It is sometimes advisable to provide a mineral mix that contains 20-25% magnesium oxide to reduce the risk of grass tetany when heavy milking goats are grazing lush small grain or grass/legume pastures in early lactation. Copper requirements for goats have not

been definitively established. Growing and adult goats are less susceptible to copper toxicity than sheep, however, but their tolerance level is not well known. Young, nursing kids are generally more sensitive to copper toxicity than mature goats, and cattle milk replacers should not be fed to nursing kids. Mineral mixes and sweet feed should contain copper carbonate or copper sulfate because these forms of copper are better utilized by the goat than copper oxide.

### ***Suggested Supplemental Feeding Program For Goats***

When goats are raised on browse, abundant forage should be made available to allow goats to be very selective and to ingest a high quality diet that will meet their nutritional requirements. When forage or browse is limited or low in protein (< 10%), lactating does (and does in the last 30 days of gestation) and developing/breeding bucks should be fed 1.0 lb/day of a 16% protein mixture (77:20:2.5:0.5 ground corn : soybean meal :goat mineral : limestone). Alternatively, ground corn and soybean meal can be substituted by whole cottonseed for lactating does. Low to medium concentration of protein (> 10% ) will meet requirements of dry does and non-breeding bucks. When forage or browse is limited or low in protein (< 10%), weanlings and yearlings should be fed ½ to 1.0 lb/day of the 16% protein mixture. Goats can be forced to eat very low quality feed including twigs, tree bark, etc., but producers should be aware that this practice will hurt the productivity of superior meat and fiber goats.

### **Grazing Management for Goats**

Grazing of forage generally provides the least expensive way of supplying nutrients to animals. Therefore, it is advantageous to develop a year round forage program which allows for as much grazing as possible every month of the year. However, good pasture management involves much more than simply turning the animals to pasture. The principles of controlled grazing of goats or sheep are similar to those used for cattle. The primary goal is to have control of the animal's grazing pattern so that one can dictate the degree of defoliation and the frequency of defoliation. To obtain efficient animal production over a number of years, the needs of the plants as well as the needs of the animals must be taken into consideration. The development of a successful forage systems/grazing management entails:

1. Adjusting the number of animals grazing a certain area (stocking density) of pasture because some forage must be left at the end of the grazing period to maintain adequate plant production. Otherwise, overuse will weaken the plants and regrowth will be slower. Adjusting the stocking rate requires experience because forage growth is not uniform throughout the year or from year to year.
2. Harvesting ungrazed forages as hay or silage at an immature stage of growth when forage growth is more rapid than it can be grazed. This will provide high quality feed when grazing is not available. Cross fencing will keep animals concentrated on small areas while excess growth accumulate on other paddocks. Under those circumstances, short duration rotational grazing through a series of paddocks, or strip grazing a rapidly growing pasture by allowing animals access to only enough forage to carry them for one day using a movable fence, are alternatives to consider.
3. Overseeding bermuda pastures with legumes, ryegrass, small grains, or brassicas to extend the grazing season and to provide some high quality feed during the winter and spring.
4. Restricting the use of high quality forage, when in short supply, for the supplementation of other low quality pastures, hay or silage. This can be achieved by letting goats graze high quality forage a few hours at the end of each day, or by grazing the limited high quality supply every other day.

When the aim is to kill or reduce the amount of unwanted vegetation, then greater severity and frequency of grazing is necessary. Goats will actively select major weeds at particular stages of growth. As a rule, effective control of unwanted vegetation can be achieved in two years. Therefore, the advantages of the goat in feeding strategy must be weighed against its disadvantages. Being a browsing animal, the goat stunts tree growth and prevents the regeneration of forests and thus should be managed carefully in areas desired for forests. Goats could be very useful, however, in areas where regrowth of brush and trees is not desirable.



## **Grazing Time**

Some livestock producers confine their animals at night for protection from straying or predation. However, confinement means that grazing time is reduced and that the animals spend more time in unsanitary lots or pens. Reduced grazing time due to confinement at night is even more critical during the hot and humid summer months, because animals may not forage efficiently during the hottest periods of the day. If animals must be confined at night, allowing the animals to graze during the cooler parts of the day would increase production as a consequence of improved feed intake resulting from increased grazing time.

## **Fencing For Goats**

Goats can be controlled with 4-5 strands of smooth electrified wire. The wire spacings can vary from 6 to 8 inches near the ground to 8 to 12 inches for the top strands. Perimeter fence height should be at least 42 inches tall. A high wire, or an offset wire set one foot inside the fence near the top, may be needed if goat jumping is a problem. As a rule, goats will crawl rather than jump a fence, so the bottom wire should be kept close to the ground. A grounded barb wire laid along the ground will help with predator control, especially in mountainous areas. Training animals to respect electric wire fences can be done effectively by forcing animals to stay in a small paddock which encourages them to "test" the wire.

Woven wire (6" x 6" opening) is effective, but costs at least twice that of a 5 strands electric fence. Further, horned goats frequently become caught in the wire. To address this problem with existing fences, an electric wire offset about 9 inches from the woven wire fence and about 12 to 15 inches from the ground will reduce the number of animals caught in the woven wire fence. However, this practice also reduces control of forage growth on the fence line. Woven wire with a 6" x 12" opening is a new and cheaper alternative than the woven wire with a 6" x 6" opening, that does not require an electric offset wire. Horned goats usually do not get caught or, if caught, they are able to free themselves because of the larger opening.

Boundary fences should control all stock at all times. However, interior fences may be made of 3 to 4 wires, assuming animals are well trained. Because goats like to climb, the corners of fences should not have the diagonal bracing for posts or the animals will climb out of the pasture. Corner posts should be driven with a deadman or H-braces.

## **Mixed Grazing and Stocking Rates**

The differences in feeding behavior among cattle, sheep and goats uniquely fit each species to the utilization of different feeds available on a farm. These differences should be considered in determining the best animal species to utilize a particular feed resource. Feeding behavior is also important in determining whether single or multi-species will best utilize available plant materials. Most studies indicate greater production and better pasture utilization are achieved when sheep and cattle or sheep, cattle and goats are grazed together as opposed to grazing only sheep or goats or cattle alone. This is especially true where a diverse plant population exists.

Under mixed grazing conditions (more than one ruminant species grazing in the same paddock) on fescue/orchardgrass-clover where the forage supply is low and the nutritive value is high, goats and sheep may be at a disadvantage. Under those conditions, the animal with the largest mouth (cattle, horse) has an advantage because it can grasp more material per unit of time. In addition, food intake by goats is rapidly reduced and may stop if the pasture is soiled or trampled, even with an ample amount of pasture remaining.

Generally one cow eats about the same amount of feed as 6 to 8 goats (Table 3). Because of the complimentary grazing habits, the differential preferences and the wide variation in vegetation within most pastures, one to two goats could be grazed with every beef cow in NC without adversely affecting the feed supply of the beef herd. The selective grazing habits of goats in combination with cattle would eventually produce pastures which would be more productive, of higher quality, and with little weed problems as a result of the mixed grazing.

TABLE 1. ESTIMATED NUTRIENT COMPOSITION OF VARIOUS FEEDS<sup>1</sup>

PLANT TYPE	TDN, %	CRUDE PROTEIN, %
Whole cottonseed	88	22
Corn	86	9
Soybean meal (48%)	82	44
Soybean hulls, ground	75	14
Wheat middlings	80	19
Pasture, vegetative	60-76	12-24
Pasture, mature	50-60	8-10
Pasture, dead leaves	35-45	5-7
Fescue hay, 6 weeks growth	58-62	8-11
Fescue hay, 9 weeks growth	48-53	7-9
Bermuda hay, 7 weeks growth	54-58	9-11
Bermuda hay, 12 weeks growth	47-50	7-9
Alfalfa hay	50-63	13-20
Honeysuckle, leaves+buds	70+	16+
Honeysuckle, mature	68+	10+
Sumac, early vegetative	77	14
Oak, buds and young leaves	64	18
Persimmon leaves	54	12
Hackberry, mature	40	14
Kudzu, early hay	55	14
Juniper leaves	64	6
Acorns, fresh	47	5
Curled dock	74	13
Chicory	65	15
Mimosa leaves	72	21
Mulberry leaves	72	17

<sup>1</sup>Nutrient requirements of Goats in Temperate and Tropical Countries. 1981 National Research Council.

TABLE 2. DAILY NUTRIENT REQUIREMENTS FOR MEAT PRODUCING GOATS<sup>1,2</sup>

NUTRIENT	YOUNG GOATS <sup>3</sup>		DOES (80 lb)			BUCK (80-120 lb)
	Weanling (30 lb)	Yearling (60 lb)	Dry (Pregnant)	Lactating Avg Milk	Lactating High Milk	
Dry matter, lb	2.0	3.0	4.5	4.5	5.0	5.0
TDN, %	68	65	60	60	65	60
Protein, %	14	12	10	11	14	11
Calcium, %	.6	.4	.4	.4	.6	.4
Phosphorus, %	.3	.2	.2	.2	.3	.2

<sup>1</sup> Nutrient Requirements of Goats in Temperate and Tropical Countries. 1981. National Research Council.

<sup>2</sup> Pinkerton, F. 1989. Feeding Programs for Angora Goats. Bulletin 605. Langston University

<sup>3</sup> Expected weight gain >.44 lb / day.

TABLE 3. ESTIMATED STOCKING RATES OR FEED NEEDS FOR GOATS, SHEEP AND CATTLE ON PASTURE<sup>1</sup>

PASTURE TYPE	GOATS	SHEEP	COW
		Head <sup>1</sup>	
Good quality pasture system	6-8	5-6	1
Good brush-browse system	9-11	6-7	1
		Head/acre	
Wheat/alfalfa system	10-12	8-9	1.5
Alfalfa pasture, Oklahoma	12-15	10-11	1.9

<sup>1</sup> Number of animals to consume similar amount of feed.

## FORAGE BASED DAIRY GOAT MANAGEMENT

**Steven P. Hart and B. R. Min**

*E (Kika) de la Garza Institute for Goat Research  
Langston University  
Langston, Oklahoma 73050*

Pastures have not typically been utilized for milk production with dairy goats. Well, goats have been put on pastures, but for the most part, pastures have not been managed to be the major source of high quality forage for the dairy goats. Often, pastures were not fertilized and allowed to mature. Goats were usually fed hay and they nibbled some pasture as they wanted to. There is little published information about pastures for goats - a little from Mexico on brushy pastures with low levels of milk production and some from France which is in French. Nonetheless, there are a few goat producers in the US who are utilizing pasture for their milking goats.

Most of the information available for dairy production on pastures comes from dairy cow research. There has been a renaissance in pastures for dairy cows, mostly with the smaller dairies. The chief reason for going to pastures is reduced feed costs and increased profitability of the operation even though milk production levels are reduced. One economic study showed that pasturing dairy cows improved profitability as much as using bovine growth hormone. Another benefit of pasturing has been improved animal health and reduced health expenses. This is probably a consequence of reduced production level and animal stress and the benefit of sunshine and fresh air. However, the level of management required is much higher because the pastures must be managed as intensively as the animals. An additional benefit is less barn cleaning and less time required to take care of animals since the time required for feeding is reduced.

Some international literature has shown that pasture can affect the quality and flavor of cheese made from cow milk. There is virtually no work on this subject in dairy goats. Another potential benefit is that the concentration of conjugated linoleic acid in cow milk is increased by pasture. The less grain used, the greater the concentration of conjugated linoleic acid. Conjugated linoleic acid is a compound in milk that has been identified as being anticarcinogenic (prevents cancer) and antiatherosclerotic (prevents the clogging of arteries). It is the only animal product that has been identified as an anticarcinogen. Also, since organic grain is very expensive, organic goat milk could be produced cheaper on organic pasture since a minimum of grain would be required.

Pasture management is of paramount importance if milk production from pastures is to succeed. The goal of pasture management is to supply high quality pasture starting at the beginning of lactation and maintain high quality forage in sufficient quantities throughout the lactation. The forage must be high in quality and be available when animals are lactating. Unless you are quite far south, you are unlikely to have any pasture growing between mid-December and mid-March. Therefore, it would be difficult to have pasture for kidding in February. For most of Oklahoma, cool season annuals such as wheat start producing in mid-March and kidding should be timed accordingly. Wheat and other cool season annuals (rye, oats) have the high quality that is necessary for high levels of milk production. Alfalfa is a good high quality pasture, but has the disadvantage of being later in the season (grazing beginning mid-April) and high cost of pasture establishment. Outside of alfalfa, goats like few legumes. In our experience, goats eat little of white, red, crimson, or arrowleaf clover. However, they seem to love Berseem clover, which can be overseeded with wheat. Berseem clover provides high quality forage between wheat and crabgrass. We have multiple pastures of wheat and Berseem clover. In late spring, we disk a pasture every week or two and overseed crabgrass/sudan grass into them. By staggering the planting, we can have an

uninterrupted supply of high quality forage. Crabgrass is one of the highest quality warm season grasses. There are a number of other warm season grasses that are appropriate, including Johnsongrass, millet, and sudangrass. We are planning on including annual lespedeza into our warm season pastures. We have begun using cowpeas for late summer grazing. They grow well in the hot dry summer and provide high quality forage that the goats relish.

One needs to adjust to the grazing behavior of goats. Initially, when goats were put to pasture, they bawled for the barn and alfalfa hay. After 4 or 5 days, they finally decided to accept their fate and put their heads down to graze. We have had to learn which forages dairy goats do well on and which ones are not appropriate. Initially, the goats did not like the cowpeas, but after 4 or 5 days, they decided they loved them. Goats love the Berseem clover. Water is provided in each pasture. It would be good if the water could be shaded in the hot summer to keep the water and goats cooler. Also, a portable shade is provided. It was built on a hay wagon undergear and has a corrugated metal roof about 8' off the ground and is 12 × 24', which provides sufficient shade for 50-60 goats. It was our intent to put a mineral box on the portable shade. We are experimenting with other crops for milking goats such as Puna chicory. Crops meriting investigation include perennials such as orchardgrass, which would improve sustainability and reduce tillage needs.

We have conducted two years of research grazing dairy goats. This study also involved different levels of grain supplementation. Milk production for these two years are shown in Figure 1. This is averaged over all levels of grain which will be discussed later. The lactation curves look fairly normal, but milk production is much lower for the first year than the second year. This can be attributed to three factors. First, goats were in lower body condition in year 1 and did not have adequate body reserves for the following lactation. Another factor was that we had some gaps in our forage system, i.e., there were some times that we did not have adequate amounts of high quality forage available for grazing. Also, we had problems with internal parasites the first year that surprised us. The problem was that the dewormer that we used did not work. Since animals in the confinement part of our operation are on concrete during lactation, they do not pick up many internal parasites and therefore we did not realize that the dewormer was not working. Does were pastured October through early March when cold weather reduced parasite problems. We did not realize that our dewormer was not working until we grazed goats during the warm, moist spring. We learned from our mistakes the first year and had much better levels of milk production the second year.

Internal parasites are one of the biggest problems in using pastures for dairy goats. The first problem is that you are limited in that which dewormers can be used for lactating animals (Panacur, Valbazen, Eprinex, and Rumatel). We have dewormer resistance to the first two dewormers, but the latter two dewormers are quite effective for us. Ivermectin and Cydectin are secreted in the milk for a long time and should never be used in lactating animals. Fecal egg counts must be done every 3 weeks to stay on top of the parasite problem. Dairy does should be dewormed when fecal egg counts exceed 800 eggs per gram. Pasture rotation and the tillage of pastures helps to reduce pasture contamination. Another practice that would be useful is grazing another animal species (such as horses or cattle) on the pasture following the goats. These animals would consume the larvae and clean up the pastures. Another practice that reduces larva contamination is to make hay after grazing.

Table 1 shows the effect of different levels of grain supplementation on milk production. We calculated that animals should be able to consume enough pasture to produce about 3.3 lb of milk per day and planned on three levels of grain supplementation for milk produced above this amount. One treatment had no supplemental grain such as one may use if organic milk or high CLA milk is to be produced (treatment D). The second grain level was 1/3 lb of grain for every lb of milk over 3.3 lbs (treatment C), and the third level was 2/3 lb of grain for every lb of milk over 3.3 lbs (treatment B). Treatment A is our control where animals are in the barn and fed alfalfa hay and grain

at the same level as treatment B. We fed an additional pound of grain to treatments A, B, and C the first 8 wk of lactation as lead feeding. Does were limited to no more than 4.4 lb of grain per day to prevent acidosis. In the first year, milk yield declined with grazing and grain level, although as discussed previously, pre-kidding body condition was an important factor. In the second year, milk production of grazing goats with the lower level of grain supplementation was similar to control animals in the barn. It is not known why the higher level of grain supplementation produced lower levels of milk. Also in Table 1, the lactation curve characteristics for each treatment and year are shown. Does in year 1 had lower peak yields, especially with lower levels of grain because the peak yield occurred earlier than in the second year. Milk yields peaked earlier because does exhausted body reserves sooner since they had lower body condition. Persistency (ability to sustain milk production) was also lower for goats fed lower levels of grain. In the second year when does were in better body condition, milk yield peaked at similar levels for all treatments. Peak yield tended to occur earlier in the goats being fed pasture alone, probably a consequence of energy limitation. Persistency of all treatments was similar during the second year. Milk production responded to grain, but not dramatically. Figure 2 shows that milk production increased by 1.7 lb for every added pound of grain supplement fed. Also, it shows that animals were able to produce about 3.3 lb of milk with no grain, although, some animals on the study did much better.

Fat percentage of milk tended to be lower for animals with no grain supplementation (Table 1), probably reflecting the energy restriction of animals on this diet. Protein and lactose followed a similar trend presumably for the same reason. Despite this limitation, cheese made from milk produced on pasture alone or with the low level of grain was shown to have higher flavor scores.

In conclusion, dairy goats on pasture can have acceptable levels of milk production with some minor changes in milk composition, especially where grain supplementation is absent. Grazing dairy goats requires additional management demands, especially for the pasture. In areas with quite dry summers, irrigation may be necessary to insure an uninterrupted supply of forage. Internal parasites need to be monitored and controlled. For the production of organic milk or high milk high in conjugated linoleic acid, goats may produce significant levels of milk from high quality pasture alone. Pasture may offer potential for producing cheese with unique flavors.

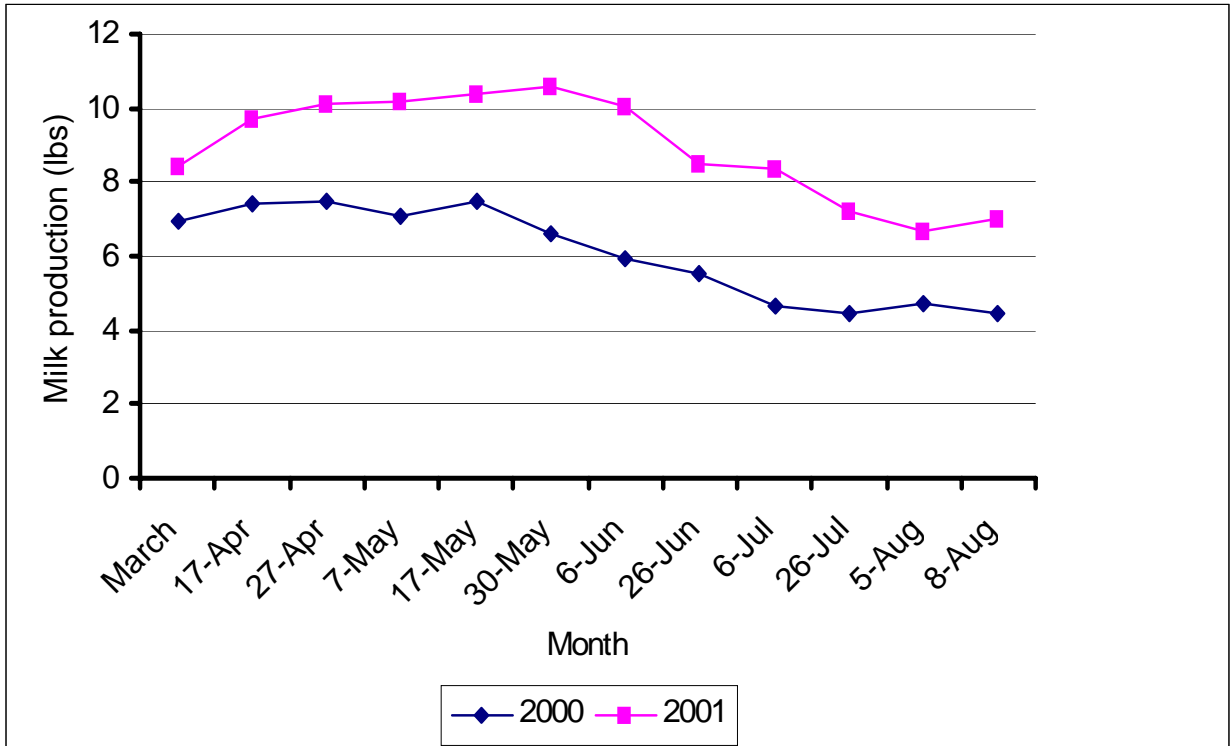

**Figure 1.** Lactation curve for dairy goats over two years

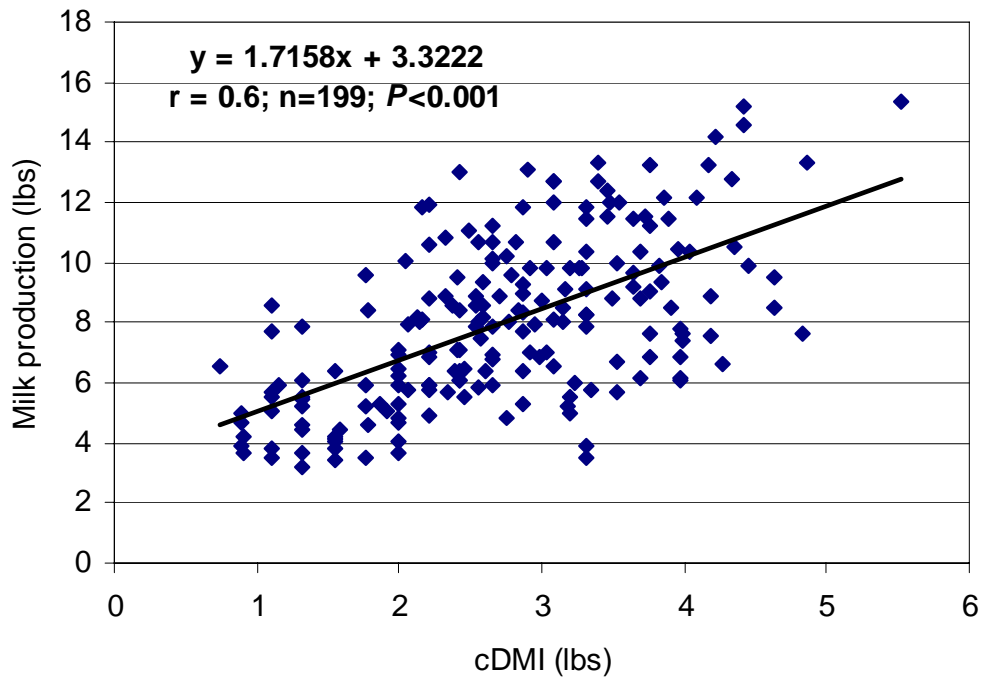

**Figure 2.** Effect of level of grain supplementation on milk production

Table 1. Milk production of grazing goats with different levels of grain supplementation

Item	Year	Treatment			
		A	B	C	D
Milk production (lb/day)	1	7.55 <sup>a</sup>	6.47 <sup>b</sup>	5.65 <sup>c</sup>	4.73 <sup>d</sup>
	2	8.91 <sup>a</sup>	8.05 <sup>b</sup>	9.17 <sup>a</sup>	7.74 <sup>b</sup>
Lactation peak (lb/day)	1	8.8 <sup>a</sup>	8.1 <sup>b</sup>	7.7 <sup>b</sup>	7.3 <sup>b</sup>
	2	12.1	10.3	11.2	10.1
Days to peak	1	44 <sup>a</sup>	32 <sup>b</sup>	32 <sup>b</sup>	22 <sup>c</sup>
	2	41	37	40	36
Persistency	1	6.52 <sup>a</sup>	6.18 <sup>b</sup>	6.06 <sup>b</sup>	5.64 <sup>c</sup>
	2	6.34	6.32	6.37	6.22
Composition					
Milkfat (%)	1	3.11	3.16	3.17	3.03
	2	3.23 <sup>a</sup>	3.16 <sup>a</sup>	3.11 <sup>a</sup>	2.99 <sup>b</sup>
Protein (%)	1	3.05 <sup>a</sup>	3.12 <sup>b</sup>	3.19 <sup>b</sup>	3.04 <sup>a</sup>
	2	3.18 <sup>a</sup>	3.07 <sup>b</sup>	3.01 <sup>b</sup>	2.80 <sup>c</sup>
Lactose (%)	1	4.09 <sup>a</sup>	4.14 <sup>a</sup>	4.10 <sup>a</sup>	3.99 <sup>b</sup>
	2	4.16 <sup>b</sup>	4.24 <sup>a</sup>	4.19 <sup>b</sup>	4.00 <sup>c</sup>

\*Treatment A = control group confined in the barn and fed alfalfa hay supplemented with 2/3 lb of grain for each pound of milk over 3.3 lb/day; Treatment B = grazed on pasture and supplemented with 2/3 lb of grain for each pound of milk over 3.3 lb/day; Treatment C = grazed on pasture and supplemented with 1/3 lb of grain for each pound of milk over 3.3 lb/day; Treatment D = grazed on pasture alone, no grain supplementation.

<sup>a,b,c</sup>Means without a common superscript are significantly different (P < 0.05).



*The proper citation for this article is:*

*Hart, S. P. and B. R. Min. 2002. Forage Based Dairy Goat Management. Pages 36-40  
in Proc. 17th Ann. Goat Field Day, Langston University, Langston, OK.*

# Forage Utilization

## Additional Resources

### Books

**Small- Scale Livestock Farming: A Grass Based Approach for Health, Sustainability, and Profit** Ekarius, Carol. 1999. Storey Books, Pownal, VT. 217 p.

Not specific to any species of livestock; contains farmer profiles and quite a bit of holistic planning and economic information. Very complete in treatment of rotational grazing.

**Southern Forages** Ball, D.M., C. S. Holveland, and G.D. Lacefield. 2002. Potash & Phosphate Institute (PPI). Norcross, Georgia. 322 p.

This handy book includes color photos to help in forage identification, as well as a very readable and useful treatment of forage programs, options in forages, establishing and managing the grazing of forages, minimizing stored feed requirements, poisonous plants, and much more. A chapter on forage quality is followed by a chapter on the nutrient requirements of livestock. All keepers of grazing livestock in the South will benefit from reading and using this book. Features slick paper, compact size, readable font, lots of graphics and tables and photos. Softcover: "From dashboards of trucks to libraries, this book will be dog-eared from regular use." (Dr. Jimmy Henning, University of Kentucky Extension Forage Specialist)

Order from:

Potash & Phosphate Institute (PPI)  
655 Engineering Drive, Suite 110  
Norcross, Georgia 30092-2837  
Phone: 770-825-8082  
E-mail: [circulation@ppi-far.org](mailto:circulation@ppi-far.org)

**Targeted Grazing: A Natural Approach to Vegetation Management and Landscape Enhancement**

National Sheep Industry Improvement Center and American Sheep Industry Association. 2006. American

Sheep Industry Association, Centennial, CO. 199 p.

To view online or order a copy, visit  
[www.cnr.uidaho.edu/rx-grazing/Handbook.htm](http://www.cnr.uidaho.edu/rx-grazing/Handbook.htm)

Or contact:

American Sheep Industry Association  
9785 Maroon Circle, Suite 360  
Englewood, CO 80112  
303-771-3500, ext. 32

**More Sheep, More Grass, More Money** Schroedter, Peter. 1997. Ramshead Publishing, Ltd. Moosehorn, Manitoba. p.112

Personal experiences of the author emphasizing the need to make a profit with the sheep enterprise. It includes examples of how to cut costs and increase profits. Emphasis on grazing management. Very practical.

### Web sites

**Intermountain Planting Guide** Jensen, Kevin, and Howard Horton, Ron Reed, and Ralph Whitesides. Utah State University. 106 p.

[http://extension.usu.edu/files/publications/publication/pub\\_\\_7717229.pdf](http://extension.usu.edu/files/publications/publication/pub__7717229.pdf)

**Extending Grazing and Reducing Stored Feed Needs**

<http://agebb.missouri.edu/mfgc/2009extgraz.pdf>

**University of Wisconsin Extension Pasture Management and Grazing**

[www2.uwrf.edu/grazing](http://www2.uwrf.edu/grazing)

**Livestock for Landscapes**

[www.livestockforlandscapes.com](http://www.livestockforlandscapes.com)

**BEHAVE- Behavioral Education for Human Animal Vegetation and Ecosystem Management**

[www.behave.net](http://www.behave.net)

# Health



In this section:

- Managing Internal Parasites in Sheep and Goats
- Tools for Managing Internal Parasites in Small Ruminants: Copper Wire Particles
- Tools for Managing Internal Parasites in Small Ruminants: Sericea Lespedeza
- Integrated Parasite Management for Livestock
- Predator Control for Sustainable and Organic Livestock Production
- Basic Meat Goat Facts

(continued)

# Health (continued)



- Monitoring the Body Condition of Meat Goats
- Preparing Meat Goats for the Breeding Season
- Heat Detection and Breeding in Meat Goats
- Internal Parasites That Affect Sheep and Goats
- Drugs (Anthelmintics) Commonly Used to Control Gastro-intestinal Parasites (worms) in Small Ruminants in the U.S.
- Procedure for Counting Fecal Eggs
- McMaster Fecal Egg Count Procedure
- FAMACHA Information Guide
- Smart Drenching

(continued)

# Health (continued)



- Controlling Sore Mouth in Meat Goats
- Coccidiosis in Lambs
- Is it necessary to vaccinate goats against overeating disease and tetanus?
- Scrapie Factsheet
- Scrapie Identification Requirements
- Additional resources

# Managing Internal Parasites in Sheep and Goats

A Publication of ATTRA - National Sustainable Agriculture Information Service • 1-800-346-9140 • www.attra.ncat.org

By Margo Hale  
 NCAT Agriculture  
 Specialist  
 © NCAT 2006

## Contents

Introduction.....	1
Parasite Primer .....	2
Parasitism .....	2
Resistance to Dewormers .....	3
Pasture Management ...	4
New Techniques .....	5
Other Techniques.....	6
Conclusion.....	7
Resources .....	7
References .....	8

Internal parasite management, especially of *Haemonchus contortus* (barberpole worm, stomach worm), is a primary concern for the majority of sheep and goat producers. These parasites have become more difficult to manage because of developed resistance to nearly all available dewormers. This publication discusses new techniques to manage parasites and to prolong the efficacy of dewormers. New management tools that remain under investigation are also discussed. A list of resources follows the narrative.



Owners of this Katahdin ewe and her lambs are able to manage internal parasites using sustainable techniques. NCAT photo by Margo Hale.

## Introduction

The management of internal parasites, primarily *Haemonchus contortus* (barberpole worm), is considered by many to be the biggest production concern for small ruminants. “There are many important diseases of sheep and goats,” notes University of Georgia researcher Ray Kaplan, DVM, PhD, “but none are as ubiquitous or present as direct a threat to the health of goats as internal parasites.” (Kaplan, 2004a). The cost of internal parasite infection includes treatment expense,

reduced animal weight gains, and even animal death.

These parasites are difficult to manage because on some farms they have developed resistance to all available commercial dewormers. (Zajac, Gipson, 2000) Resistance to dewormers is now seen worldwide (Kaplan, 2004b). Producers can no longer rely on drugs alone to control internal parasites. Rather, an integrated approach that relies on sustainable methods to manage internal parasites should be employed.



*Most animals in a flock are not visibly affected by parasites and do not need to be treated with dewormers. Photo by Linda Coffey.*

## Parasite Primer

Internal parasites (worms) exist by feeding off of their host. Some types do this directly, by attaching to the wall of the digestive system and feeding on the host's blood. These types of parasites cause anemia in the host, as well as other symptoms. *Haemonchus contortus* (barberpole worm) is one example of this type. Others live off the nutrients eaten by the host; these cause weight loss but not anemia.

Mature parasites breed inside the host and "lay eggs," which pass through the host and are shed in the feces. After the eggs pass out of the host, they hatch into larvae. Warm, humid conditions encourage hatching. The larvae need moisture to develop and move. They migrate out of the feces and up blades of grass (usually 1 to

2 inches). When an animal (sheep or goat) grazes, they may take in parasite larvae along with the grass blade. An animal can also pick up parasite larvae by eating from a feed trough that is contaminated by manure.

Parasite numbers increase over time when conditions are favorable (warm, wet). Internal parasites get out of control and cause damage when their numbers

### Internal parasite numbers:

- Increase with number of host animals
- Increase during warm, humid weather
- Increase when pastures are grazed too short
- Decrease during hot, dry weather
- Decrease if a non-host animal (cattle or horses) graze the same pasture
- Decrease with pasture rest time, as the larvae naturally die off

grow beyond what the animal can tolerate. In order to manage internal parasites, it is important to understand the parasite cycle and factors that encourage their production.

## Parasitism

Animals raised in confinement or on pasture-based systems will almost certainly be exposed to internal parasites at some point in their lives. Dry environments, such as arid rangelands, will pose less of a threat for parasite infections. Warm, humid climates are ideal for worms, and therefore animals will have more problems with internal parasites in these climates.

Sheep and goats should be managed so that parasitism is not evident. Sheep and goats will always host some level of parasite burden. Certain signs of parasitism are seen when the parasite load becomes excessive or when the animal's immunity can no longer overcome the adverse effects of the parasitism. (Scarfe, 1993) Young animals and those with weakened immune systems due to other diseases are most affected by internal parasitism. A combination of treatment and management is necessary to control parasitism so that it will not cause economic loss to the producer. (Scarfe, 1993)

While it is ideal to manage animals so there are no visible effects of parasitism, some will nonetheless succumb to the burden of internal parasites. Learn to recognize the signs of internal parasite infections and offer early treatment.



*Due to lowered immunity, young stock and pregnant or lactating animals are more likely to be affected by internal parasites. Photo by Linda Coffey.*



Loss of condition and rough hair coat indicate parasitism.  
Photo courtesy of Jean-Marie Luginbuhl.



Bottle jaw is a sign of parasitism.  
Photo courtesy of Jean-Marie Luginbuhl.

### Signs of Parasitism

- Loss of condition
- Rough hair coat
- Scours, diarrhea
- Bottle jaw
- Pale mucous membranes (eyelids, gums), indicating anemia
- Death

## Resistance to Dewormers

Producers were once instructed to deworm all of their animals every three to six months. Many producers dewormed even more often, as often as every four weeks in humid climates. It is now known that this practice is not sustainable.

Drug resistance is the ability of worms in a population to survive drug treatments that are generally effective against the same species and stage of infection at the same dose rate. (Kaplan, 2004b) Over-use of dewormers has led to resistance, and available dewormers are now ineffective. In an article from 1993, David Scarfe predicted the development of drug resistance.

Suppressive deworming is probably the most effective means of keeping parasite

numbers lowered for a period of time. However, this method will also eventually lead to resistance to the anthelmintics(s) used much more rapidly than if other strategies of control are utilized. One point to consider here is alternating the use of different drugs.

It is considered by this author, and several expert parasitologists, that rapid rotation of different drugs is ill-advised as this will lead to resistance of multiple drugs – something that the small ruminant industries certainly do not need. (Scarfe, 1993)

Scarfe recognized the unsustainable practices that were being used long before parasites were resistant to dewormers in the U.S.

Some farms still have dewormers that continue to work, while others have no effective dewormers. This is a problem because no new dewormers for sheep and goats are currently under development. (Kaplan, 2004b)

## Development of Resistance to Dewormers

Internal parasites, especially *H. contortus*, have developed drug resistance. Drug treatment gets rid of the worms that are susceptible to that particular drug; resistant parasites survive and pass on “resistant” genes.



## Overview of Available Dewormers for Sheep and Goats

Several types of dewormers are available for use in sheep and goats. Many are not approved for use in sheep and goats, however, so work with a veterinarian to ensure proper “off-label” use. The different classes of dewormers have different modes to kill worms. The level of resistance depends on the class of dewormer and how often the drug was used on a particular farm.

Drug Class	Common Names/ Brands	Effectiveness
Benzimidazoles	Albendazole (Valbazen®), Fenbendazole (Safeguard®)	High prevalence of resistance
Avermectin/ Milbemycins	Ivermectin (Ivomec®)  Moxidectin (Cydectin®)	Ivermectin— least effective of all available drugs  Moxidectin—resistance becoming common where used frequently
Imidazothiazoles/ Tetrahydropyrimidine	Levamisole (Tramisol®), Pyrantel (Strongid®), Morantel (Rumatel®)	Low to moderate prevalence of resistance

### Related ATTRA Publications

Integrated Parasite Management for Livestock

Goats: Sustainable Production Overview

Meat Goats: Sustainable Production

Dairy Goats: Sustainable Production

Sustainable Sheep Production

Dairy Sheep

Small Ruminant Sustainability Checksheet

Worms that are not treated are called “refugia.” The concept of refugia has been largely overlooked in the past. Having some worms in refugia (not treated) insures that a level of genes remain sensitive to dewormers. (Kaplan, n.d.) A surviving population of untreated worms dilutes the frequency of resistant genes. Consequently, when a dewormer is required, it will be effective because the worms will be susceptible to treatment. (Kaplan, n.d.)

When fewer numbers of animals receive treatment, the refugia population remains large. The more refugia, the better. Sustainable techniques, such as FAMACHA®, fight drug resistance by increasing refugia.

In contrast, several practices accelerate drug resistance. They include frequent deworming (more than three times a year), underdosing (often caused by miscalculation of body weight), treating and moving to clean pasture, and treating all animals, regardless of need. These practices lead to resistance because they decrease the number of worms susceptible to dewormers (refugia).

Since no dewormer is 100 percent effective 100 percent of the time, worms that survive a dose of dewormer are resistant to that

dewormer. Frequent deworming increases the rate resistance develops.

Each time animals are dewormed, the susceptible worms are killed. The strong ones survive and lead to a population of very resistant worms. Underdosing causes larger numbers of stronger worms to survive. The weakest, most susceptible worms are killed. But because of the weak dose, more of the stronger worms will be able to survive and reproduce, creating a population of stronger worms. Once an animal has been treated, only resistant worms remain. If the animals are moved to a clean pasture they deposit only resistant worms on the pasture. There are no susceptible worms to dilute the worm population. Treating all animals regardless of need ignores the importance of refugia and will lead, in time, to a population of worms unkillable by dewormers.

## Pasture Management

Numerous techniques can be used to control parasitism. Pasture management should be a primary tool to control internal parasites. Sheep and goats ingest infective parasite larvae from pasture. The rate at which they are ingested can be controlled through pasture management.



*Eating higher off the ground reduces the number of parasite larvae consumed. Photo by Margo Hale.*

Most worm larvae crawl up the plant only one to two inches from the ground. Preventing animals from grazing below that point decreases the number of worm larvae ingested. Animals that eat closer to the ground tend to have more problems with internal parasites. It is important to monitor animals and the pasture. Allowing animals to graze pastures too short results in more parasites consumed and reduced feed intake, therefore harming the animal in two ways. It also inhibits pasture regrowth.

Larvae migrate no more than 12 inches from a manure pile. Livestock not forced to eat close to their own manure will consume fewer larvae. Providing areas where animals can browse (eat brush, small trees, etc.) and eat higher off of the ground helps to control parasite problems.

Decreasing the stocking rate decreases the number of worms spread on a pasture. The



*Sheep grazing at Maple Gorge Farm in Prairie Grove, Arkansas. Photo by Margo Hale.*

more animals you have on one pasture, the more densely the worms are deposited. Animals on densely stocked pastures are more likely to have parasite problems. Grazing sheep and goats with cattle, or in a rotation with cattle, can also reduce internal parasite problems. Cattle do not share the same internal parasites as sheep and goats. Cattle consume sheep and goat parasite larvae, which helps “clean” the pasture for the small ruminants.

Certain forages have also been shown to control parasite problems. Tannin-rich forages, such as sericea lespedeza, have been shown to help reduce internal parasite egg counts. (Min and Hart, 2003; Shaik et al., 2004) Other plants, including plantain, chicory, and wormwood, also have an anthelmintic effect, although wormwood also produces toxic compounds. Providing tannin-rich forages and diverse pastures can help animals battle internal parasites.

## New Techniques

### FAMACHA<sup>®</sup>

FAMACHA<sup>®</sup> is a system for classifying animals into categories based upon level of anemia. (Kaplan, n.d.) It was developed in South Africa and has been validated in the U.S. (Kaplan et al, 2004)

This system identifies anemic animals on a 1 to 5 scale by examining the eyelids of sheep and goats (see photo next page). The system treats only animals that are anemic (a sign of parasitism). This reduces the use of dewormers, slows the development of resistant worms, and saves the producer money. Most importantly, it also allows the producer to select animals that are healthier. By breeding the healthiest animals and culling the weaker individuals, the flock or herd becomes stronger over time. FAMACHA<sup>®</sup> is only effective for



*High levels of tannins in forages such as sericea lespedeza reduce worm burdens. Photo courtesy of Jean-Marie Luginbuhl.*

## FAMACHA® System Saves Money and Reduces Stress

On Maple Gorge Farm, in Prairie Grove, Arkansas, busy schedules prevented the farmers from monitoring parasites. By late summer, the sheep had been grazing for months with no treatment. The farmers noticed a young lamb with bottle jaw and feared they had a huge problem on their hands.

They considered not bringing the animals in for treatment because they were low on dewormer. They knew they wouldn't have enough to treat all of the animals. Then they remembered the FAMACHA® system that they had recently been trained in. Using the FAMACHA® system, they decided to sort off, identify and treat only the 4s and 5s (anemic animals), and a few 3s that were thin.

To their surprise, only 9 of the 65 sheep actually needed treatment. Identification numbers and FAMACHA® scores were recorded. They decided any ewe scoring a 4 or 5 would not be kept in the flock.

This whole process took less than an hour. Treating only the animals in need reduced stress for the animals and farmers, and also saved money. After using the FAMACHA® system and seeing how easy it was and the impact it had on their flock, the farmers at Maple Gorge Farm are believers in the system.



Demonstration of the FAMACHA® technique. Photo by Margo Hale.

the treatment of *H. contortus*. Producers must be trained by a veterinarian or other trained animal health professional in order to use FAMACHA®. (Kaplan, n.d.) However, this technique is simple to learn and quick and easy to use. For more information on FAMACHA®, see *Other Resources*, page 8.

## Other Techniques

### Selecting Resistant Animals

Several other techniques can be used to help manage internal parasites. There are several breeds of sheep and goats that show resistance to parasites. There is something in their genetic makeup that causes them to host a smaller parasite load. Breeds such as Gulf Coast Native, St. Croix, Katahdin, and Barbados Blackbelly show an increased



Sheep breeds such as Gulf Coast Native show resistance to parasites. Photo by Linda Coffey.

resistance to parasite loads. Spanish, Myotonic, and Kiko goat breeds have also shown a tolerance to parasites. Resistance will vary within breeds as well. Some animals, regardless of breed, will be more resistant to parasites than others. Having

parasite-resistant animals will decrease the need for dewormers.

Within any breed, certain animals are more tolerant of parasite loads than others. These resilient animals can host a large parasite burden, yet show few signs of parasitism. Some animals will carry a heavier parasite load than others. Research shows that 20 to 30 percent of the animals carry 70 to 80 percent of the worms. (Kaplan, n.d.) Producers should cull animals that are always “wormy,” and select for animals that have a natural resistance or tolerance to a slight parasite burden. The FAMACHA® system will help you identify those more tolerant animals.

### Copper Wire Particles

Recent research has been performed on the use of copper wire particles to control internal parasites. Studies show that copper wire particle boluses administered to lambs decrease parasite loads. (Burke et al., 2004) However, higher doses may increase the risk for copper toxicity in sheep. Copper wire particle treatments do not appear to be effective in mature sheep (Burke et al., 2005), but may work in mature goats. (Chartier et al., 2000)

## Smart Drenching

Smart Drenching refers to the ways producers can use dewormers (drenches) more selectively and effectively. —Southern Consortium for Small Ruminant Parasite Control, SCSRPC, n.d.

Used in conjunction with FAMACHA<sup>®</sup>, Smart Drenching helps slow the development of parasite resistance.

The components of Smart Drenching are:

1. Find out which dewormers work by performing a fecal egg count reduction test or a DrenchRite larval developmental assay.
2. Weigh each animal prior to deworming. Double the cattle/sheep dose when deworming goats for all dewormers, except Levamisole, which should be dosed at 1.5 times the cattle/sheep dose in goats.
3. Deliver the dewormer over the tongue in the back of the throat with a drench tip or drench gun.
4. Withhold feed 12 to 24 hours prior to drenching with benzimidazoles, ivermectin, doramectrin, and Moxidectin, if possible.
5. Benzimidazole efficacy is greatly enhanced by repeating the drench 12 hours after the first dose. Albendazole should not be used during early pregnancy (during buck/ram exposure and up to 30 days after their removal).
6. Simultaneously use two classes of dewormers if resistance is suspected.
7. Drench only the animals that need treatment. (SCSRPC, n.d.)

Research is still underway on this technique, especially for long-term studies to determine the copper levels that are toxic to sheep.

### Nematode-Trapping Fungus

Another tool currently being researched is the use of nematode-trapping fungus. This fungus traps parasite larva in the feces, interrupting its life cycle. Research has shown that it is “effective in significantly reducing development of L3 and appears to be an effective tool for biocontrol of parasitic nematodes in goats” (Terrill et al., 2004). The use of these fungi is still being researched.

## Conclusion

Control of internal parasites in sheep and goats can be a daunting task. Previous control methods are no longer viable, so new techniques must be used. Techniques such as increased pasture management, Smart Drenching, FAMACHA<sup>®</sup>, and selecting parasite-resistant animals can help to manage internal parasites. These techniques reduce dependence on dewormers and lead to a more sustainable parasite management program. New techniques, such as copper wire particles and nematode-trapping fungus, are being researched and developed. These developments may increase the tools available to battle internal parasites of small ruminants.

## Resources

The following publications are available from ATTRA. These publications are free of cost. Copies can be requested by calling 800-346-9140 or at our website: [www.attra.ncat.org](http://www.attra.ncat.org).

- Goats: Sustainable Production Overview
- Meat Goats: Sustainable Production
- Dairy Goats: Sustainable Production
- Sustainable Sheep Production
- Dairy Sheep
- Small Ruminant Sustainability Checksheet
- Small Ruminant Resources
- Integrated Parasite Management for Livestock
- Predator Control for Sustainable and Organic Livestock Production
- Multispecies Grazing
- Matching Livestock and Forage Resources
- Rotational Grazing
- Pastures: Sustainable Management

## Other Resources

Southern Consortium for Small Ruminant Parasite Control, [www.scsrpc.org](http://www.scsrpc.org)

Association of Small Ruminant Practitioners  
1910 Lyda Avenue, Bowling Green, KY 42104-5809  
Phone: 270-793-0781, <http://aasrp.org>

Management of Barber Pole Worm in Sheep and Goats in the Southern U.S.

[www.attra.org/downloads/goat\\_barber\\_pole.pdf](http://www.attra.org/downloads/goat_barber_pole.pdf)

Maryland Small Ruminant Page

[www.sheepandgoat.com](http://www.sheepandgoat.com)

FAMACHA® Information

[www.vet.utk.edu/departments/LACS/pdf/FAMACHA.pdf](http://www.vet.utk.edu/departments/LACS/pdf/FAMACHA.pdf)

[www.scsrpc.org/SCSPRC/FAMACHA/famacha.htm](http://www.scsrpc.org/SCSPRC/FAMACHA/famacha.htm)

Langston University, Oklahoma:

- E. (Kika) de la Garza Institute for Goat Research  
[www.luresext.edu/goats/index.htm](http://www.luresext.edu/goats/index.htm)
- Information about Internal & External Parasites of Goats, [www.luresext.edu/goats/training/parasites.html](http://www.luresext.edu/goats/training/parasites.html)

## References

Burke, J., J. Miller, D. Brauer. 2005. The effectiveness of copper oxide wire particles as an anthelmintic in pregnant ewes and safety to offspring. *Veterinary Parasitology*, 131, 291-297

Burke, J., J. Miller, D. Olcott, B. Olcott, T. Terrill. 2004. Effect of copper oxide wire particles dosage and feed supplement level on *Haemonchus contortus* infection in lambs. *Veterinary Parasitology*, 123, 235-243.

Chartier, C., E. Etter, H. Heste, I. Pors, C. Koch, B. Dellac. 2000. Efficacy of copper oxide needles for the control of nematode parasites in dairy goats. *Vet. Res. Commun.*, 24, 389-399.

Kaplan, R. 2004(a). Responding to the emergence of multiple-drug resistant *Haemonchus contortus*: Smart Drenching and FAMACHA®. Proceedings of the Georgia Veterinary Medical Association 2004 Food Animal Conference, Irwinville, GA (1-9).

Kaplan, R. 2004(b). Responding to the emergence of multiple-drug resistant *Haemonchus contortus*: Smart Drenching and FAMACHA® [PowerPoint]. Retrieved July 12, 2005, [www.scsrpc.org/Files/Files/Misc/FL%20Goat%20Prodn%20Conf%20June04%20Comp%20format.pdf](http://www.scsrpc.org/Files/Files/Misc/FL%20Goat%20Prodn%20Conf%20June04%20Comp%20format.pdf)

Kaplan, R. (n.d.) Open letter to sheep and goat producers regarding the FAMACHA® program. Retrieved July 12, 2005, [www.scsrpc.org/Files/Files/Misc/FAMACHA%20response%20to%20requests%20from%20producers%20v4.pdf](http://www.scsrpc.org/Files/Files/Misc/FAMACHA%20response%20to%20requests%20from%20producers%20v4.pdf)

[www.scsrpc.org/Files/Files/Misc/FAMACHA%20response%20to%20requests%20from%20producers%20v4.pdf](http://www.scsrpc.org/Files/Files/Misc/FAMACHA%20response%20to%20requests%20from%20producers%20v4.pdf)

Kaplan, R., J. Burke, T. Terrill, J. Miller, W. Getz, S. Mobini, et al. 2004. Validation of the FAMACHA® eye color chart for detecting clinical anemia in sheep and goats on farms in the southern United States. *Veterinary Parasitology*, 123, 105-120.

Min, B., S. Hart. 2003. Tannins for suppression of internal parasites. *Journal of Animal Science*, 81 (E. Supplement 2), E102-E109.

Scarfe, A.D. 1993. Approaches to Managing Gastrointestinal Nematode Parasites in Small Ruminants. Retrieved August 31, 2005, from [www.clemson.edu/agronomy/goats/handbook/nematode.html](http://www.clemson.edu/agronomy/goats/handbook/nematode.html)

Shaik, S., T. Terrill J. Miller, B. Kauakou, G. Kannan, R. Kallu, et al. 2004. Effects of feeding sericea lespedeza hay to goats infected with *Haemonchus contortus*. *South African Journal of Animal Science*, 34 (Supplement 1), 248-250.

Southern Consortium for Small Ruminant Parasite Control [SCSRPC]. (n.d.). Smart Drenching for Sheep and Goats [Brochure]. Fort Valley, GA: Author.

Terrill, T.H., M. Larsen, O. Samples, S. Husted, J.E. Miller, R.M. Kaplan, et al. 2004. Capability of the nematode-trapping fungus *Duddingtonia flagrans* to reduce infective larvae of gastrointestinal nematodes in goat feces in the southeastern United States: dose titration and dose time interval studies. *Veterinary Parasitology*, 102, 285-296.

Zajac, A., T. Gipson. 2000. Multiple anthelmintic resistance in goat herd. *Veterinary Parasitology*, 87, 163-172.

### Managing Internal Parasites in Sheep and Goats

By Margo Hale  
NCAT Agriculture Specialist  
©NCAT 2006

Paul Driscoll, Editor  
Karen Van Epen, Production

This publication is available on the Web at:  
[www.attra.ncat.org/attra-pub/parasitesheep.html](http://www.attra.ncat.org/attra-pub/parasitesheep.html)  
or  
[www.attra.ncat.org/attra-pub/PDF/parasitesheep.pdf](http://www.attra.ncat.org/attra-pub/PDF/parasitesheep.pdf)

IP293  
Slot 289  
Version 100406

# Tools for Managing Internal Parasites in Small Ruminants: Copper Wire Particles

A Publication of ATTRA - National Sustainable Agriculture Information Service • 1-800-346-9140 • [www.attra.ncat.org](http://www.attra.ncat.org)

By Margo Hale,  
Joan Burke, Jim Miller,  
and Tom Terrill

NCAT/ATTRA and  
Southern Consortium  
for Small Ruminant  
Parasite Control

2007

## Contents

Introduction.....	1
Copper Oxide Wire Particles (COWP).....	2
Things You Should Know about Copper .....	2
COWP Boluses .....	3
How to Make COWP Boluses.....	3
COWP Results .....	4
Summary .....	5
Resources .....	6
References .....	6



*Sheep and goat producers must rely on a combination of techniques to manage internal parasites.*

## Introduction

**I**nternal parasite management, especially of *Haemonchus contortus* (barber pole worm, stomach worm), is a primary concern for the majority of sheep and goat producers. These parasites have become more difficult to manage because of developed resistance to nearly all available dewormers. A severe infection of barber pole worm causes anemia, reduced animal production, bottle jaw, and—if not treated—death of infected sheep and goats.

Mature parasites breed inside the host and “lay eggs,” which pass through the host and

are shed in the feces. After the eggs pass out of the host, they hatch into larvae in the pellet. Warm, moist conditions encourage hatching of the eggs and development into infective larvae. The larvae need moisture, such as dew or rain, to break open the fecal pellet, releasing the larvae. The infective larvae migrate out of the feces and up blades of grass (usually 1 to 3 inches). When an animal (sheep or goat) grazes, it may take in parasite larvae along with the grass blade, resulting in infection. Numbers of infective larvae on the pasture increase over time when environmental conditions are favorable (warm, wet).

**O**ver-use of dewormers has led to dewormer resistance, and as a consequence most available dewormers are now ineffective.

Parasites are now developing resistance to all commercially available anthelmintics (dewormers). Drug resistance is the ability of worms in a population to survive drug treatment of the animal at the standard prescribed dosage. Over-use of dewormers (frequent deworming and treating all animals regardless of need) has led to dewormer resistance, and as a consequence most available dewormers are now ineffective. Producers cannot rely on anthelmintics alone to control internal parasites. Therefore, it is important to use several tools to manage internal parasites.

The following are tools that can be used to manage internal parasites. For more information see ATTRA's *Managing Internal Parasites in Sheep and Goats*.

### Pasture Management

- Maintain forage height greater than 2 inches
- Provide areas of browse (brush, shrubs, small trees, etc.)
- Maintain low stocking rate
- Graze sheep and goats with cattle, or in a rotation with cattle or horses
- Provide tannin-rich forages, such as sericea lespedeza
- Harvest hay off pastures
- Avoid wet patches in a pasture, such as from a leaky water trough
- Fence-off naturally-wet areas

### Selective Deworming or FAMACHA©

- A system for classifying animals based on levels of anemia (according to eye mucous membrane color)
- Treat only animals with symptoms of the barber pole worm (anemia)
- Reduces the use of dewormers and slows development of resistance
- Is only effective for the treatment of *H. contortus* (barber pole worm)

### Selecting Resistant Animals

- Several breeds show resistance to internal parasites
- Individual animals can demonstrate resistance to parasites
  - o Resistant animals have a lower host parasite burden and are not negatively affected by the parasites (don't show signs of parasitism, remain productive)
  - o FAMACHA scores can be helpful for selection

### Copper Oxide Wire Particles

Copper oxide wire particles (COWP) have also been found to reduce parasite loads in sheep and goats. COWP were developed for copper deficiency in cattle and sheep. Sheep are very susceptible to copper toxicity, which can result in death. The form of copper used

#### Things you should know about copper...

- Copper is important for immune function in livestock.
- Sheep are very sensitive to copper accumulation in the liver, which causes toxicity.
- The amount of copper required by sheep is not greatly different from the toxic level, making copper level an important consideration when mixing sheep rations or feeding mineral.
  - o The margin of safety between the required amount of copper (10 ppm) and toxic level (25 ppm) is very narrow in sheep.
- Some sheep breeds are more susceptible to copper toxicity than others (Texel and dairy breeds).
- Copper sulfate is more readily absorbed than copper oxide, creating a greater risk for copper toxicity.
  - o Recommending COWP use for controlling worms does not endorse the use of high copper sulfate mineral mixes to control parasites.
- There are complex mineral interactions that affect copper absorption; deficiencies in other minerals can increase the risk for copper toxicity.
  - o Low levels of molybdenum can increase risk of copper toxicity
- Pastures fertilized with poultry waste may have high copper levels.
  - o Sheep should not be fed poultry wastes, due to the high copper levels
- Goats are less susceptible to copper toxicity, tolerating up to 80 ppm.
  - o While not common, copper toxicity in goats can occur (13).

in COWP is poorly absorbed, reducing the risk of copper toxicity.

The exact mechanism of how copper wire particles control internal parasites is not yet fully understood. Researchers believe copper has a direct effect on internal parasites. It may also help to boost the immune system. Both effects help to manage internal parasites.

## Copper Oxide Wire Particle Boluses

COWP boluses can be made and administered on farm. Copper boluses (Copasure<sup>®</sup>) are available for use for copper deficiency in cattle. These boluses can be repackaged into doses suitable for growing sheep and goats. The minimum dose that has demonstrated control in some studies is 0.5 g, but as much as 2-4 g may be necessary.

### How to make COWP boluses for parasite control in sheep and goats

- Purchase copper boluses (Copasure<sup>®</sup>, available in 12.5 g and 25 g boluses)
- Obtain smaller gel capsules
  - Available at your local pharmacy or health food store, also available from veterinary supply houses at times.
- Repackage cattle bolus into smaller gel capsule to make 0.5g dose
  - Size 1 gelatin capsules filled 1/3 full
  - Size 3 capsules filled 3/4 full
- Administer bolus with a pill gun designed for pets or wooden dowel with PVC pipe



Gelatin capsules, Size 3 and Size 1, filled with 0.5 g or 500 mg of COWP. Photo courtesy of Dr. Joan Burke.

Animals can be treated again after 4-6 weeks, if necessary. Animals should receive no more than four (if 0.5 or 1 g is used) or two (if 2 or 4 g is used) COWP boluses in a worm season. It should be noted that COWP has been found to be effective on reducing abomasal (*H. contortus*) only and not intestinal worms. COWP has been found to be effective against *H. contortus* in mature goats most of the time, though sometimes marginally effective. Other control strategies may be more effective in mature animals. As with all anthelmintic treatments, it is important to work with your veterinarian.

COWP should not be the only method used for controlling internal parasites. COWP boluses should be thought of as one component of a complete parasite management strategy. COWP boluses should be used selectively, treating only the animals that need it. Using the FAMACHA<sup>®</sup> system is one way to determine animals that should receive a COWP bolus. Selective treatment is advised to reduce the risk of worms developing resistance to COWP. Other parasite management techniques are mentioned earlier in this publication. The use of COWP can also help slow the development of anthelmintic drug resistance, as fewer anthelmintics are used.



Suggested pill guns to administer COWP to sheep and goats. Top pill gun is marketed for dogs and cats (Dr. Hanson's<sup>®</sup> Bullseye pill gun) and bottom is wooden dowel inserted into a 1/2 inch PVC pipe with a rubber band wrapped around the dowel to serve as a stop. Photo courtesy of Dr. Joan Burke.

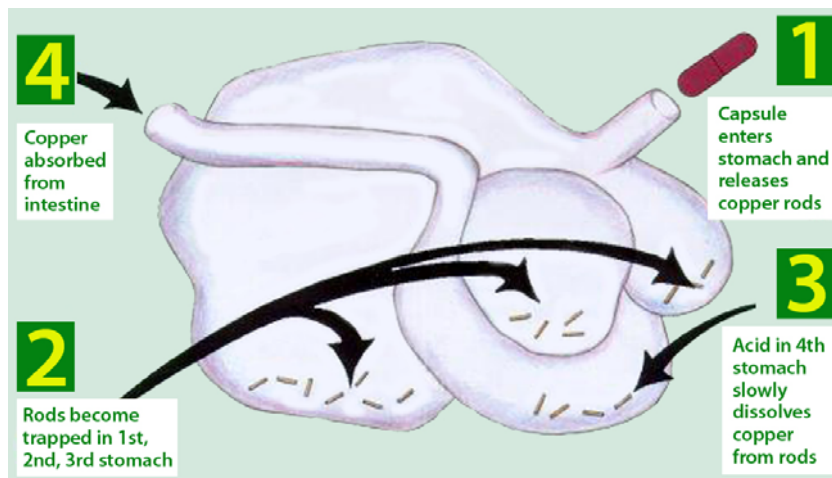

Illustrates the fate of COWP boluses in the animal. (adapted from [www.animax-vet.com](http://www.animax-vet.com))



## COWP Results

There have been several research trials studying the effects of COWP on internal parasites in sheep and goats. The following table summarizes the results.

Animals Used	Treatment	Results	Notes
Crossbred (Katahdin, Dorper, St. Croix cross) ram lambs	0.5 g or 1 g COWP every 6 weeks (May-October)	Fecal egg counts (FEC) reduced, fewer <i>H. contortus</i> found in fecals of lambs treated with COWP	Lower COWP doses just as effective at reducing internal parasites as higher doses in other studies. COWP was highly effective in reducing nematode infection for 4-6 weeks (3)
5-6 month old hair breed lambs	0, 2, 4, or 6 g COWP	FEC reduced in lambs receiving 2, 4, or 6 g COWP; <i>H. contortus</i> numbers in the abomasums were reduced (5)	
Mature Katahdin ewes, prior to lambing	0, 2, or 4 g COWP	FEC reduced for those receiving COWP (2 g-66%; 4 g- 55%), FEC increased in untreated animals	Evidence that lambs received copper from treated ewes (in utero and through milk) (4)
Lactating Polypay ewes and their offspring	Mature ewes—0, 0.5, 1, or 2 g COWP 60 days after lambing Offspring—0, 0.5, 0.75, 1 or 2 g COWP at 2 months of age	Ewes—FEC were lower for those treated with 1 or 2 g COWP Offspring—All doses of COWP lowered FEC	In this study, a beneficial effect for ewes was seen with 2 g COWP. COWP appear to be less effective in mature ewes compared with lambs. (7)
Boer-cross yearling goats	0, 5, or 10 g COWP bolus	FEC were lower for animals treated with COWP	While FEC were lower for animals treated with COWP, they still were over 2000 eggs/g. (9)
Boer-cross weanling goats	0 or 2.5 g COWP	FEC initially decreased by ~50% (from 2930 eggs/g to 1525 eggs/g) for those treated with COWP, but then rose to over 3000 eggs/g	FEC started to rise 3 weeks after COWP treatment. (10)
Mature Spanish does grazing winter pasture	0 or 4 g COWP	Overall FEC were similar between 0 and 4 g COWP.	On days 0, 7, and 14 FEC of untreated goats increased while FEC of COWP treated goats remained low. (8)
Yearling Spanish x boer cross bucks	0, 5, or 10 g COWP	FEC were similar in 0, 5, or 10 g COWP treated goats and decreased between day 0 and 35.	Concentrations of copper in the liver were greater in COWP-treated goats than untreated goats. (8)
Boer x Spanish doe and wether kids	0, 0.5, 1, 2, or 4 g COWP	FEC were lower on days 7, 14, and 21 compared with untreated kids, but were similar by day 28.	Average daily gain tended to increase with dose of COWP up to 2 g then decreased at 4 g. (8)

Animals Used	Treatment	Results	Notes
Boer x Spanish wether kids	0 g COWP, 5 g COWP, apple cider vinegar drench, or vinegar drench and 5 g COWP	There was no effect of vinegar drenching on FEC in 0 or 5 g COWP treated kids. FEC were reduced in COWP treated kids. (8)	
Boer and Spanish x Boer does	0 or 2 g COWP while supplemented with 220 g of corn and soybean meal or 220 g of cottonseed meal	FEC were reduced in COWP treated goats and remained lower than untreated does until day 21 for corn soybean meal-supplemented does and day 28 in cottonseed meal-supplemented does. FEC were lower in CSM than corn soybean meal-supplemented does that received COWP.	At the end of this study, 2 g COWP was administered to all goats and resulted in a 79% reduction in FEC 7 days later. (8)
Boer yearling does	0 or 5 g COWP grazing either tall fescue or sericea lespedeza	Doses of 5 g COWP decreased FEC and sericea lespedeza grazing tended to decrease FEC.	By day 28 approx. 50% of untreated does required deworming, but no COWP-treated does required deworming. (8)
Yearling Spanish does, prior to breeding	Multi-trace element/vitamin ruminal bolus containing copper oxide	Fecal egg counts were reduced (by 80%) and remained low, while untreated animals' FEC increased (6)	
Spanish and Boer does, 6 weeks before kidding	Multi-trace element/vitamin ruminal bolus containing copper oxide	<i>H. contortus</i> decreased; FEC were reduced (by 60%)	Reduction in FEC lasted 3-4 weeks, similar to anthelmintic treatments (6)



Producers must use a holistic approach to managing internal parasites.

## Summary

Copper oxide wire particles (COWP) have been proven to be an effective method of controlling *H. contortus* (barber pole worm) in sheep and goats. While COWP have shown positive results in reducing parasite loads, they should not be the only method of parasite control used. Research continues on the use of COWP to determine the most effective treatments for sheep and goats. COWP can be an effective component of a holistic parasite management strategy.

## Resources

Managing Internal Parasites in Sheep and Goats  
<http://attra.ncat.org/attra-pub/parasitesheep.html>

Southern Consortium for Small Ruminant  
Parasite Control  
[www.scsrpc.org](http://www.scsrpc.org)

## References

- 1) Hale, M. 2006. Managing Internal Parasites in Sheep and Goats. ATTRA publication. <http://attra.ncat.org/attra-pub/parasitesheep.html>.
- 2) Burke, J.M., Miller, J.E., & Terrill, T.H. 2007. Use of Copper Oxide Wire Particles (COWP) to Control Barber Pole Worm in Lambs and Kids. [www.scsrpc.org](http://www.scsrpc.org)
- 3) Burke, J.M. & J.E. Miller. 2006. Evaluation of multiple low doses of copper oxide wire particles compared with levamisole for control of *Haemonchus contortus* in lambs. *Veterinary Parasitology* (139). p. 145-149.
- 4) Burke, J.M., Miller, J.E., & D.K. Brauer. 2005. The effectiveness of copper oxide wire particles as an anthelmintic in pregnant ewes and safety to offspring. *Veterinary Parasitology* (131). p. 291-297.
- 5) Burke, J.M., Miller, J.E., Olcott, D.D., Olcott, B.M., & T.H. Terrill. 2004. Effect of copper oxide wire particles dosage and feed supplement level on *Haemonchus contortus* infection in lambs. *Veterinary Parasitology* (123). p. 235-243.
- 6) Burke, J.M. & J.E. Miller. 2006. Control of *Haemonchus contortus* in goats with a sustained-release multi-trace element/vitamin ruminal bolus containing copper. *Veterinary Parasitology* (141). p. 132-137.
- 7) Burke, J.M., Morrill, D., & Miller, J.E. 2007. Control of gastrointestinal nematodes with copper oxide wire particles in a flock of lactating Polypay ewes and offspring in Iowa, USA. *Veterinary Parasitology* (146). p. 372-375.
- 8) Burke, J.M., Terrill, T.H., Kallu, R.R., Miller, J.E., J. Mosjidis. 2007. Use of copper oxide wire particles to control gastrointestinal nematodes in goats. *Journal of Animal Science* (85). p. 2753-2761.
- 9) Glennon, H.M., Luginbuhl, J.M., Mueller, J.P., Zajac, A.M., Anderson, K.L., Sparks, J.W., Brown, T.T., & C. Brownie. 2004. Effect of copper oxide needles on gastrointestinal parasites in grazing meat goats. *Journal of Animal Science* 80 (Suppl. 2): 29.
- 10) Luginbuhl, J.M., Glennon, H.M., & J.P. Mueller. 2006. Effect of copper-oxide needles on gastrointestinal parasites in weanling meat goats control-grazed on bermudagrass pastures. *Journal of Animal Science* 84 (Suppl. 2): 21.
- 11) Copasure<sup>®</sup> information. [www.animax-vet.com/index.php?option=content&task=view&id=29&Itemid=31](http://www.animax-vet.com/index.php?option=content&task=view&id=29&Itemid=31)
- 12) Schoenian, S. 2000. Copper Toxicity in Sheep. [www.sheepandgoat.com/articles/coppertox.html](http://www.sheepandgoat.com/articles/coppertox.html)
- 13) Cornish, J., Angelos, J., Puschner, B., Miller, G., & L. George. 2007. Copper toxicosis in a dairy goat herd. *Journal of American Veterinary Medicine Association* (231). p. 586-589.

### Related ATTRA Publications

- Managing Internal Parasites in Sheep and Goats
- Tools for Managing Internal Parasites in Small Ruminants: Sericea Lespedeza
- Integrated Parasite Management for Livestock
- Small Ruminant Sustainability Checksheet

## Notes:

---

**Tools for Managing Internal Parasites in Small Ruminants: Copper Wire Particles**

By Margo Hale, Joan Burke, Jim Miller, and Tom Terrill  
© 2007 NCAT

This publication is available on the Web at:  
[www.attra.ncat.org/attra-pub/copper\\_wire.html](http://www.attra.ncat.org/attra-pub/copper_wire.html)  
or  
[www.attra.ncat.org/attra-pub/PDF/copper\\_wire.pdf](http://www.attra.ncat.org/attra-pub/PDF/copper_wire.pdf)

IP317  
Slot 316  
Version 112007



# Tools for Managing Internal Parasites in Small Ruminants: Sericea Lespedeza

A Publication of ATTRA - National Sustainable Agriculture Information Service • 1-800-346-9140 • [www.attra.ncat.org](http://www.attra.ncat.org)

By Linda Coffey,  
Margo Hale,  
Tom Terrill,  
Jorge Mosjidis,  
Jim Miller, and  
Joan Burke

NCAT/ATTRA and  
Southern Consortium  
for Small Ruminant  
Parasite Control

2007

## Contents

Introduction.....	1
Sericea Lespedeza .....	3
Sericea Lespedeza Results .....	4
Using Sericea Lespedeza.....	5
Resources .....	6
References .....	6



Goat grazing sericea lespedeza. Photo by Jean-Marie Luginbuhl.

## Introduction

Control of internal parasites, especially of *Haemonchus contortus* (barber pole worm, stomach worm), is a primary concern for the majority of sheep and goat producers. These parasites have become more difficult to manage because of increasing resistance to nearly all available dewormers. A severe infection of barber pole worm causes anemia, bottle jaw, and—if not treated—death of infected sheep and goats.

Mature parasites breed inside the host and “lay eggs,” which pass through the host and are shed in the feces. After the eggs pass out of the host, they hatch into larvae. Warm, humid conditions encourage

hatching of the eggs and development into infective larvae. The larvae need moisture, such as dew or rain, to break open the fecal pellet and move. They migrate out of the feces and up blades of grass (usually 1 to 3 inches). When an animal (sheep or goat) grazes, they may take in parasite larvae along with the grass blade. Parasite numbers increase over time when conditions are favorable (warm, wet).

Parasites are now developing resistance to anthelmintics (dewormers). Drug resistance is the ability of worms in a population to survive drug (deworming) treatment of the animal at the prescribed dosage. Over-use of dewormers has led to resistance, and many available dewormers are now ineffective.

ATTRA—National Sustainable Agriculture Information Service is managed by the National Center for Appropriate Technology (NCAT) and is funded under a grant from the United States Department of Agriculture's Rural Business-Cooperative Service. Visit the NCAT Web site ([www.ncat.org/agri.html](http://www.ncat.org/agri.html)) for more information on our sustainable agriculture projects.



Ideas and research were generated by the Southern Consortium for Small Ruminant Parasite Control ([www.scsrpc.org](http://www.scsrpc.org)) and funding support for this work was provided by USDA, CSREES, Integrated Organic Program, and Capacity Building Grants Program (Award No. 2005-38814-16429). Mention of trade names or commercial products in this manuscript is solely for the purpose of providing specific information and does not imply recommendation or endorsement by the U.S. Department of Agriculture.

Producers can no longer rely on anthelmintics alone to control internal parasites. It is important to use multiple management practices to control internal parasites.

The following are tools that can be used to manage internal parasites. For more information see ATTRA's *Managing Internal Parasites in Sheep and Goats*.

## Pasture Management

- Maintain forage height greater than 3 inches (beware of patch grazing)
- Provide areas of browse (brush, shrubs, small trees, etc.)
- Maintain low stocking rate
- Graze sheep and goats with cattle, or in a rotation with cattle or horses
- Provide tannin-rich forages, such as sericea lespedeza
- Harvest hay from pastures
- Avoid wet patches in pasture, such as from a leaky water trough

## Selective Deworming

- Use a visual system (FAMACHA®) for classifying animals based on levels of anemia
  - FAMACHA® is only effective for diagnosing infection by *H. contortus* (barber pole worm)
  - Treat only animals that are anemic (a sign of parasitism)
  - Reduces the use of dewormers
  - Helps slow down drug resistance problems
  - Saves money

## Selecting Resistant Animals

- Several breeds show **resistance** to internal parasites (that is, when exposed to parasites, the animal immune system does not allow the parasites to be established in its body). Select a resistant breed if it fits your system.

- Select individual animals that demonstrate resistance to parasites
- **Resilient** animals can host a parasite burden and not be negatively affected by the parasites (don't show signs of parasitism, and they remain productive); however, they may be shedding high numbers of parasite eggs and causing illness in other animals.
- Cull animals that are most susceptible to parasites and those that contribute most to pasture contamination.

## Alternative Treatments

- Copper Oxide Wire Particles (COWP) boluses
- Garlic and other botanical materials and formulations (being tested)
- Nematode-trapping fungus (not commercially available yet)
- Condensed-tannin (CT)-containing supplements (such as sericea hay)

Condensed tannins and, in particular, the high-CT forage sericea lespedeza are discussed in this paper. An overview of current research on the topic, as well as additional resources and references, are provided. Producers can use this information to keep their animals healthier.

## Tannins

- Tannins are plant compounds that bind to proteins and other molecules.
- Tannin is related to “tanning”, as in preserving hides, and tannins are found in many plants.
- There are two main types of tannins; hydrolyzable (HT), some of which may have toxic effects on animals, and condensed tannins (CT), which are found in forage legumes (including sericea lespedeza) and other plants.
- Effects of tannins vary depending on type of tannin, concentration, and on the animal consuming the tannins.

- Negative effects may include reduced intake and reduced digestibility, leading to a decline in animal productivity. Negative effects are seen more often when CT concentration is high (above 55 g CT/kg DM in the forage). (Min et al., 2003)
- Positive effects may include an increase in by-pass protein (causing the animal to use protein more efficiently), a reduction in bloating, increased milk production, and a reduction in internal parasite numbers, egg output, and hatchability.

For more information on tannins, see the references listed at the end of this publication and the Resources section,

especially <[www.ansci.cornell.edu/plants/toxicagents/tannin](http://www.ansci.cornell.edu/plants/toxicagents/tannin)>.

According to Min et al. (2003), low concentrations of CT (20-45 g CT/kg DM) are helpful to animals, while high forage CT concentrations (>55 g CT/kg DM) may have negative effects. Results vary according to CT concentration and structure and the animal that is grazing the forage, however.

Researchers have shown that big trefoil, sulla, sanfoin, and sericea lespedeza are useful in controlling internal parasite infection in sheep and goats. Providing condensed-tannin-containing forages is one way to boost the health of sheep or goats.

**Table 1. Condensed tannin (CT) content in different forage species.\***

(Adapted from Min and Hart, 2003 and Min et al., 2005).

Forage	CT, g/kg of DM	%DM
Birdsfoot trefoil	48	4.8
Big trefoil	77	7.7
Sanfoin	29	2.9
Sulla	51–84	5.1–8.4
Lucerne (alfalfa)	0.5	.05
Sericea lespedeza	46-152	4.6–15.2
Perennial ryegrass	1.8	0.18
Chicory	3.1	0.31
Crabgrass/tall fescue mixture	3.2	0.32

\*The standard used for analysis will affect the results. For these studies, a Quebracho standard was used.

**S**ericea lespedeza is a high-tannin forage that has been scientifically proven to reduce parasite loads in sheep and goats.

## Sericea Lespedeza

Sericea lespedeza is a high-tannin forage (4–15% DM) that has been scientifically proven to reduce parasite loads in sheep and goats. The mechanism of action is not yet known. Researchers believe that the plant tannins may affect parasites either directly or indirectly (or both). Tannins may react directly with adult worms by attaching to their “skin”, causing them distress, or indirectly

by improving protein nutrition of the goat and boosting the immune system. In addition, tannins appear to reduce the hatching of fecal eggs and development of larvae, perhaps by binding to the larvae. (Min et al., 2005). The tannins could also bind with feed nutrients and possibly prevent bacterial growth in the feces (larva feed on bacteria) and so limit the feed available for larval growth, or in some other way inhibit larvae growth and movement. Adult worms





Goat grazing sericea lespedeza. Photo by Margo Hale.

residing in animals that are grazing sericea lespedeza shed fewer eggs, and the eggs that are produced have reduced hatching ability. However, when animals are moved off sericea lespedeza pastures and on to other forages, egg counts go back up, indicating that mature worms were inhibited but not killed in the short term. As animals are fed with sericea for longer periods of time, research has shown a reduction in mature worms as well (Min et al., 2005, Shaik et al., 2006, Lange et al., 2006). Reducing pasture contamination and animal worm burdens will help sheep and goats to be healthier and more productive.

### Things you should know about sericea lespedeza

- Sericea lespedeza is a legume that grows in low fertility and acid soils and was widely planted to rebuild eroded and depleted soils. It is one of the most commonly used species for planting on surface mine spoils, road banks, and other disturbed or eroding areas.
- Sericea is listed as a noxious weed in some states (Colorado and Kansas, at the time of this writing) and may become invasive or weedy in some areas.
- Where sericea is considered a noxious or invasive weed, sheep and goat grazing can help to control the plant while also helping sheep or goat parasite problems. It will not be invasive when grazed and prevented from producing seed.
- Sheep and goats may need time to adjust to grazing sericea if they are not familiar with the forage; however, they will graze it readily once they go through the adjustment period. Cattle will graze sericea if it is not too mature.
- No adjustment period is needed for feeding sericea hay, as it is readily consumed by all classes of livestock.
- Researchers are investigating the performance of animals grazing sericea or being fed sericea hay or supplement.
- Research has shown that sericea is effective against internal parasites when grazed or when fed in dried forms, such as hay or pellets.

## Sericea Lespedeza Results

There have been several research trials studying the effects of sericea lespedeza on

internal parasites in sheep and goats. The following table summarizes the results. References are included in the last column.

Animals Used	Treatment	Results	Notes
Spanish wether goats, grazing	15 days grazing sericea or rye/crabgrass, switch to other forage 15 days	Fecal egg counts (FEC) reduced (2500 vs. 710 eggs per gram), percentage of eggs developing to larvae reduced (99% vs. 58.2%)	FEC increased after switching to rye/crabgrass; tannins seemed to have short residual effect (Min et al., 2004)
Goats, confined and fed hay	Ground hay–sericea or bermudagrass– 4 week trial, all on bermudagrass hay for 3 weeks following	Reduced fecal egg counts (FEC) for sericea-fed goats (significant in 3rd and 4th weeks of trial)	FEC not significantly different once animals were taken off sericea, but still numerically lower (Shaik et al., 2004)

Animals Used	Treatment	Results	Notes
Goats, confined and fed hay (75% of diet) and grain (25%)	Ground sericea (0, 25, 50, 75%) and/or bermudagrass (75, 50, 25, 0%) in combinations equaling 75% hay; levels testing dose of SL needed, 6 weeks	FEC reduced for those fed SL at all levels, greater reduction as % SL increases and with time; at 6 weeks, 75% SL hay, 91.9% reduction	Optimum level of SL hay appeared to be 50-75% of total diet (Dykes et al., 2006), but 25% was also beneficial, reducing number of adult barber pole worms in the stomach by 58% (unpublished data)
Goats, confined and fed hay and grain	Sericea hay or bermudagrass hay, 7 weeks	FEC reduced, number of adult worms reduced, hatchability of eggs into L-3 larvae reduced in goats fed sericea hay	Egg counts dropped by about 80% one week after sericea feeding started; reduction increased to almost 90% by end of trial. Both abomasal and small intestinal worms reduced and female worms reduced more than male worms. Male and female <i>H. contortus</i> were reduced by 61 and 76%, respectively (Shaik et al., 2006)
Lambs, fed hay; natural and experimental <i>Haemonchus contortus</i> infections	Sericea hay or bermudagrass hay, 7 weeks, bermudagrass an additional 2 weeks	FEC reduced for those receiving sericea (67-98%); FEC increased after sericea feeding stopped. Sericea also reduced worm numbers.	SL fed as hay reduced naturally infected worm burdens 67%; reduced establishment of incoming larvae 26%. (Lange et al., 2006)
Angora does, grazing	Sericea or crabgrass/tall fescue grazing, 81 days	Goats on sericea had reduced FEC and fewer adult worms. Inhibited larval activity. Improved weight gain and immune responses. No adverse effect on does and kids (3.6 kg/kid).	Goats grazing sericea reduced both <i>H. contortus</i> (89%) and <i>Trichostrongylus</i> parasites (50%). (Min et al., 2005)
Kiko-Spanish kids fed ground hay and pellets; natural infection	Sericea hay in ground and pelleted forms, ground bermudagrass hay	Pelleted sericea reduced FEC 78%; increased PCV 32% compared with bermudagrass	Pelleting increased effectiveness of sericea hay against parasitic worms; reduced adult <i>H. contortus</i> 75% (Terrill et al., 2007)

## Using Sericea Lespedeza

Producers should not rely on sericea as the sole method for controlling internal parasites. However, sericea can be useful as one part of a complete parasite management strategy. Sericea has been shown to reduce hatchability and fecundity (egg laying ability) of internal parasites, and in that way it will help reduce pasture contamination with larvae. Also, when used for longer periods

of time, it can reduce the number of adult worms. Researchers are working to determine the most effective and economical ways to use sericea lespedeza as a substitute for anthelmintics, or as a “deworming pasture.” More information will be available as the research is done. Continue to check the Southern Consortium for Small Ruminant Parasite Control Web site at [www.scsrpc.org](http://www.scsrpc.org) for updates.

## Resources

---

Managing Internal Parasites in Sheep and Goats  
[www.attra.ncat.org/attra-pub/parasitesheep.html](http://www.attra.ncat.org/attra-pub/parasitesheep.html)  
*This concise paper includes information gathered from the research of the Southern Consortium for Small Ruminant Parasite Control (see below) and includes helpful information and pictures explaining many of the concepts needed for an integrated parasite control program.*

Southern Consortium for Small Ruminant Parasite Control

[www.scsrpc.org](http://www.scsrpc.org)  
*The Consortium is a group of researchers and educators who are working on the parasite problem. This site includes publications, upcoming events such as FAMACHA® trainings, contacts for Consortium members, and many other items helpful to producers and educators. This is the place to look for current research results and information about the latest recommendations for sustainable parasite control.*

Tannins

[www.ansci.cornell.edu/plants/toxicagents/tannin](http://www.ansci.cornell.edu/plants/toxicagents/tannin)  
*An interesting look at the properties and uses of tannins.*

Sericea Lespedeza

[www.aces.edu/dept/forages](http://www.aces.edu/dept/forages)  
*Alabama forages site; this includes link to Alabama forages lespedeza page, as well as access to articles and experiment station results from Auburn University. The lespedeza page includes three articles; titles are listed below.*

- AU Grazer - A Sericea Lespedeza that Tolerates Heavy Grazing
- Invasive Plant Misconception
- Sericea Lespedeza: A Pasture, Hay, and Conservation Plant

[www.ag.auburn.edu/agrn/mosjidis/sericeallespedeza.htm](http://www.ag.auburn.edu/agrn/mosjidis/sericeallespedeza.htm)

*This links to the research page; includes the articles above and an article about establishing lespedeza stands. Exploring the buttons on the left will yield information about cultivars and about Auburn research.*

[www.aces.edu/pubs/docs/A/ANR-1318/ANR-1318.pdf](http://www.aces.edu/pubs/docs/A/ANR-1318/ANR-1318.pdf)

*Sericea Lespedeza: A Pasture, Hay, and Conservation Plant. Extension publication, 4 p. Written by Don Ball and Jorge Mosjidis, this concise paper*

*includes information about establishment, management, varieties, and use for internal parasite control.*

[http://plants.usda.gov/factsheet/pdf/fs\\_lecu.pdf](http://plants.usda.gov/factsheet/pdf/fs_lecu.pdf)  
*USDA Plant Fact Sheet: Chinese lespedeza. 2 p.*

<http://plants.usda.gov/java/profile?symbol=LECU>  
*From the USDA Plants database. Lots of information, including a map showing distribution, links to other sites, pictures, taxonomy and other specific information.*

## References

---

Dykes, G.S., T.H. Terrill, S.A. Shaik, J.E. Miller, B. Kouakou, G. Kannan, J.M. Burke, R.M. Kaplan, and J.A. Mosjidis. 2006. Effect of sericea lespedeza hay on gastrointestinal nematode infection in goats. In: Proceedings of the 2006 Conference of the American Forage and Grassland Council. March 10-14. San Antonio, Texas. Volume 15. p. 245–249.

Hale, M. 2006. Managing Internal Parasites in Sheep and Goats. ATTRA publication. [www.attra.ncat.org/attra-pub/parasitesheep.html](http://www.attra.ncat.org/attra-pub/parasitesheep.html).

Lange, K.C., D.D. Olcott, J.E. Miller, J.A. Mosjidis, T.H. Terrill, J.M. Burke, and M.T. Kearney. 2006. Effect of sericea lespedeza (*Lespedeza cuneata*) fed as hay, on natural and experimental *Haemonchus contortus* infections in lambs. *Veterinary Parasitology* 141. p. 273–278.

Min, B.R., and S.P. Hart. 2003. Tannins for suppression of internal parasites. *Journal of Animal Science* 81 (E. Suppl. 2):E102–E109.

Min, B. R., T.N. Barry, G.T. Attwood, and W.C. McNabb. 2003. The effect of condensed tannins on the nutrition and health of ruminants fed fresh temperate forages: a review. *Animal Feed Science and Technology* 106. p. 3–19.

Min, B. R., W.E. Pomroy, S.P. Hart, and T. Sahlu. 2004. The effect of short-term consumption of a forage containing condensed tannins on gastro-intestinal nematode parasite infections in grazing wether goats. *Small Ruminant Research* 51. p. 279–283.

Min, B.R., S.P. Hart, D. Miller, G.M. Tomita, E. Loetz, and T. Sahlu. 2005. The effect of grazing forage containing condensed tannins on gastro-intestinal nematode parasite infection and milk composition in Angora does. *Veterinary Parasitology* 151. p. 105–113.

Shaik, S.A., T.H. Terrill, J.E. Miller, B. Kouakou, G. Kannan, R.K. Kallu, and J.A. Mosjidis. 2004. Effects of feeding sericea lespedeza hay to goats infected with *Haemonchus contortus*. South African Journal of Animal Science. Volume 34 (Supplement 1). p. 248–250.

Shaik, S.A., T.H. Terrill, J.E. Miller, B. Kouakou, G. Kannan, R.M. Kaplan, J.M. Burke, and J.A. Mosjidis.

2006. Sericea lespedeza hay as a natural deworming agent against gastrointestinal nematode infection in goats. *Veterinary Parasitology* 139. p. 150–157.

Terrill, T.H., J.A. Mosjidis, D.A. Moore, S.A. Shaik, J.E. Miller, J.M. Burke, J.P. Muir, and R. Wolfe. 2007. Effect of pelleting on efficacy of sericea lespedeza hay as a natural dewormer in goats. *Veterinary Parasitology* 146, p. 117–122.

#### Related ATTRA Publications

- Managing Internal Parasites in Sheep and Goats
- Tools for Managing Internal Parasites in Small Ruminants: Copper Wire Particles
- Integrated Parasite Management for Livestock
- Small Ruminant Sustainability Checksheet

## Notes:

---

**Tools for Managing Internal Parasites in Small Ruminants: Sericea Lespedeza**

By Linda Coffey, Margo Hale, Tom Terrill, Jorge Mosjidis, Jim Miller, and Joan Burke

NCAT/ATTRA and Southern Consortium for Small Ruminant Parasite Control, 2007

This publication is available on the Web at:  
[www.attra.ncat.org/attru-pub/sericea\\_lespedeza.html](http://www.attra.ncat.org/attru-pub/sericea_lespedeza.html)  
or [www.attra.ncat.org/attru-pub/PDF/sericea\\_lespedeza.pdf](http://www.attra.ncat.org/attru-pub/PDF/sericea_lespedeza.pdf)

IP316  
Slot 315  
Version 112007



# INTEGRATED PARASITE MANAGEMENT FOR LIVESTOCK

## LIVESTOCK SYSTEMS GUIDE

ATTRA is the national sustainable agriculture information center funded by the USDA's Rural Business -- Cooperative Service.

**By Ann Wells, DVM**  
 NCAT Agriculture Specialist  
 April 1999

**Abstract**

*Internal parasites can be a major problem for producers. With parasites developing resistance to all dewormers and more farmers producing livestock by "natural" methods, there is interest in looking for alternative ways to managing parasites problems. Management is the most important thing to consider. The whole system affects internal parasites. Nutrition and pasture management can help prevent problems by improving the health of the animals. There are soil organisms that kill or prevent the development of internal parasites. Strategic deworming means planning the timing when deworming is done. This can also be an important part of any management scheme. Little is known about the effectiveness of any alternative dewormer. Changes will have to done slowly while observing their outcome.*

**Introduction**

Internal parasites are considered by some to be one of the most economically important constraints in raising livestock. Confinement and pasture-based animals are almost certain to be exposed to worms at some point in their life. Animals raised on the dry and arid rangelands are much less likely to be infested. But if these animals are brought to the more humid climates east of the Rockies, worms will be a major problem for these animals.

Most producers are aware of the problems that worms cause, which range from decreased productivity of their animals to death. Animals are usually routinely dewormed with different commercial chemicals, by owners using a variety of deworming schedules. Every

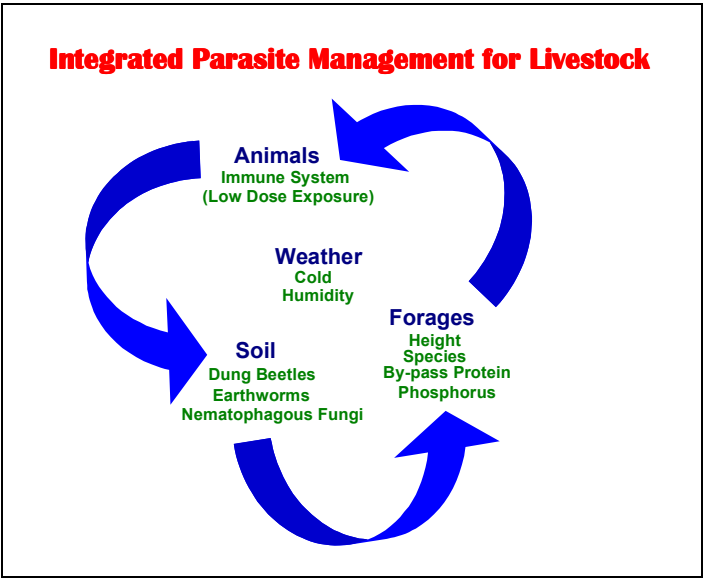

dewormer on the market has had some resistance built up to it by the internal parasites that infest livestock. This resistance means that not all the worms are killed during deworming. The surviving worms pass that genetic resistance on to offspring.

The growing concern about the resistance of internal parasites to all classes of dewormers has

**\*\*\* What's Inside \*\*\***

Introduction.....	1
Nutrition .....	2
Pasture Management .....	2
Immunity .....	4
Soil Organisms .....	5
Effect of Ivermectin on Dung Beetles .....	5
Strategic Deworming .....	5
Alternative Dewormers .....	7
Conditions with Signs Similar to Parasitism.....	8
Conclusion.....	8
References .....	8
Enclosures.....	9

caused people to look for alternatives. As dewormers lose their effectiveness, the livestock community fears increasing economic losses from worms. Much attention both in the research community and on the farm is being devoted to discovering ways to prevent and treat internal parasites without relying on heavy doses of chemical dewormers. Many people claim this treatment or that control measure works, but there are more questions than

**By looking at the whole farm as an interrelated system, it becomes apparent that there are parts of the system that can be managed to decrease internal parasites and their effects.**

answers. There is no simple alternative way of preventing or treating worms. By looking at the whole farm as an interrelated system, it becomes apparent that there are parts of the system that can be managed to decrease internal parasites and their effects. These management adjustments not only postpone the day when chemical controls no longer work, but they also may decrease costs and increase the overall health of the animal.

## **Nutrition**

Nutrition plays a major role in how well animals are able to overcome the detrimental effects of internal parasites. In fact, the signs of parasitism can often be used as a symptom of some other problem, usually poor nutrition. In an article in the *Journal of the American Veterinary Medical Association* in 1943, researchers showed that sheep placed on a high plane of nutrition were able to reduce their worm burden significantly and many of the sheep were even able to cure themselves (1).

### **By-pass Protein**

Researchers in New Zealand have been studying the effects of by-pass protein on parasitized sheep (2). They have found that by increasing the amount of protein that is not

degraded or broken down in the rumen, animals lose less weight than those animals that were not fed the increased level of by-pass protein. These researchers used fish meal as their source of by-pass protein. However, there are forages that also have an increased level of by-pass protein because they contain tannins. These include birdsfoot trefoil and lespedeza. The protein in native warm season grasses also has a higher level of by-pass protein.

### **Phosphorus**

There is also research that shows that when the phosphorus level of the diet was at a level of .28% phosphorus on a dry matter basis, the weight gain of lambs infected with parasites was increased by 40% over those lambs fed a low (.18%) phosphorus level diet (3).

## **Pasture Management**

Management of animals, pastures and any loafing areas is key to reducing the amount of internal parasite problems in livestock. An understanding of the life cycles of the different parasites within the whole soil-plant-animal system will help show the interrelationships between these three components. Managing internal parasites is just like managing fleas in dogs and cats. The major part of the parasite life cycle is outside of the animal. This point will help the producer to choose management strategies that reduce parasite levels on his or her farm and decrease the usage of chemical dewormers. The same principle is used in integrated pest management for vegetables and other crops.

Many farmers closely monitor their animals but pay little attention to the plants and soil. Pasture contamination by infective larvae is the primary factor to deal with. If you start with an understanding of the interrelationship between the animal, the plants it eats and the soil on which those plants grow, then it becomes clearer how parasites infect the animal and how they can be managed so as not to cause as many problems. Everything a farmer does to his or her animals, including the grazing management,

affects the manure, which affects the animal's environment. For example, animals that continuously graze a pasture eat the grass into the ground, while contaminating the soil with so many parasites that nothing outside of regular deworming with chemicals will control them. By using controlled grazing methods that allow pastures to rest and soil life to function well, contamination can be reduced. This reduction occurs because soil organisms, including earthworms, dung beetles, and nematophagous fungi will destroy or keep a lot of the parasite eggs and larvae from developing. Keeping the grass in a more vegetative stage, and tall enough to provide the animal with adequate forage, will provide better nutrition to keep the animal healthier, strengthening the immune system to prevent the adult worms from producing eggs. Parasites do not cause as much harm to a healthy, well nourished animal. The parasites that are present will not deplete the host as much as in an animal that is malnourished. Parasite loads affecting wildlife generally do not cause the death of the host, because the parasites need the host to survive. The same principle applies to livestock.

Pasture contamination can be reduced through management. Livestock will avoid manure piles and the grass surrounding them. This behavior also helps them avoid eating larvae. The height of the pasture sward can affect parasites. The majority of worm larvae crawl only one inch from the ground onto plants, so not allowing animals to graze below that point will cut down on a lot of infestation. This is one reason sheep tend to have more problems with internal parasites. They eat much lower to the ground than cattle do, picking up higher numbers of larvae. Therefore, it is important to monitor grazing sheep closely so they don't graze too low. Larvae migrate from the manure no more than 12 inches from the manure pile. If livestock are not forced to eat close to their own manure, they will eat fewer larvae.

With sheep and goats, the most important time to control pasture contamination is during the

periparturient rise, which is the sudden release of infective larvae and eggs within the ewe's intestinal tract. This occurs right after lambing, and is due to the ewe and doe's immune system becoming temporarily less effective. By treating animals at this time, the exposure to newborn and young lambs (those most susceptible to parasites) is minimized.

### **Other ATTRA Materials of Interest**

Assessing the Pasture Soil Resource  
Matching Livestock & Forage Resources  
Meeting the Nutritional Needs of Ruminants on Pasture  
Nutrient Cycling in Pastures  
Rotational Grazing  
Sustainable Pasture Management  
Beef Farm Sustainability Checksheet

*Contact ATTRA at (800) 346-9140 to order these and other publications.*

Good grazing management includes the use of clean pasture to minimize re-infection. Clean pasture is pasture that has not been grazed by the host animal (in this case sheep and goats) for 12 months, and therefore is not contaminated with worm larvae. It may be new pasture, pasture grazed by livestock such as cattle or horses which do not share parasites with sheep (goats do share parasites with sheep), or pasture that has been hayed, renovated, or rotated with row crops. There is some killing of parasites on pasture during the winter due to freezing and thawing; however, snow cover insulates the larvae. Summer is the time in the Southern states when most larval kill will occur on pastures. Sunlight will kill them, and this occurrence can be used to determine which pastures can be used in the fall and into the winter. Grazing down to 2-4 inches from the ground allows more sunlight to get to those larvae and increases their chances of drying out and being killed.

Warmth, oxygen and moisture are the three most important things that increase the chances that larvae will survive on pasture (4). Knowing when your pastures are apt to be driest and



coldest will help you manage them better for parasite control. Enclosures such as "Alternative Approaches to Managing Small Ruminant Gastrointestinal Nematode Parasites" discuss pasture management in more detail. Also enclosed is an article that discusses the deworming effects of certain plants, such as plantain. The plantain must be young for the animals to eat it readily as it loses palatability when it becomes mature.

Cleanliness is a defense against parasites. Feed troughs and water sources located where they can be contaminated with feces will increase the chances of livestock infestation. This is only one reason not to water directly from ponds, or to allow animals continuous access to water sources. Feeders should be cleaned and elevated. Calving and lambing areas, as well as other holding areas, should be clean and dry. Prevent the transmission of infestations from new arrivals to the herd or flock by deworming them before arrival and again three weeks later.

Sheep and goats are infested by the same species of worms. Cattle are mainly infested by other species. The cattle parasite of most concern is *Ostertagia ostertagi*, the brown stomach worm. The barber pole worm, *Haemonchus contortus*, is a stomach worm that can severely affect sheep. Enclosed is an article that discusses the life cycle and infective larval stages of worms.

## Immunity

While it is usually neither possible nor advisable to completely eliminate internal parasites in sheep or other livestock, reduction of parasite load can be achieved. Many people have found, and research has shown, that adult animals rarely need to be wormed (4). Most animals develop immunity against internal parasites, though not to the level that is developed against viruses and bacteria. This immunity keeps the

parasites from reproducing but rarely kills them. An example of an effective parasite control program can be found in Tennessee. Dennis Onks, superintendent of the Highland Rim Experiment Station in Springfield, Tennessee, has not wormed the adult cattle on the farm in eight years. They are wormed at weaning and then not again. They have never shown any signs of internal parasites and their condition is excellent. These animals are on a high plane of nutrition, have a low stress level, and are strictly culled on production. All these things work together to produce an animal that shows no signs of internal parasites.

It is the young animal whose immune system is not fully mature and the animal whose immune system is compromised by disease, inadequate nutrition, or other stress, that is most adversely affected by worms. Animals brought from western rangelands, for example, where the arid conditions keep parasites from surviving, have no immunity and can easily be overwhelmed by worms.

Every farm is different. The parasite load of the animal depends on many variables – such as stocking density, time of year, the reproductive state of the animal, etc. Good nutrition plays a big part in how well the animal's immune system mounts the proper defenses, and in the

**Many people have found, and research has shown, that adult animals rarely need to be wormed.**

animal's overall ability to tolerate the presence of some worms. Healthy and well-nourished animals will be able to develop resistance and resilience to worms and other parasites much better than thin animals that do not have good availability of quality feed (3). Resistance is the ability of an animal to prevent the establishment and maintenance of a parasite population within the gastrointestinal tract. Some individuals and some breeds show more resistance to parasitic infection than others. Research to identify characteristics in such

### **The three most important things for larvae survival:**

- Warmth
- Oxygen
- Moisture

individuals is a hot area. Culling susceptible animals can take advantage of this. Resilience is the ability of an animal to reduce production loss during a parasite infestation. Both of these traits are being looked at as ways of selecting animals that will be less susceptible to parasite effects. Animals that possess some genetic resistance or resilience can still be infected with worms. Therefore, you must keep in mind that this is just one more measure that will help control worm problems, not a cure by itself.

## Soil Organisms

There are several soil organisms that can have an impact on parasites. Managing pastures to favor populations of beneficial soil organisms will decrease parasite levels on pastures. Oxygen is the primary requirement for worm eggs and larvae to survive and develop. Earthworms have been shown to ingest worm eggs and larvae, either killing them or carrying them far enough below ground to keep them from maturing. Dung beetles ingest and disperse manure, taking it to their burrows, thus keeping eggs and larvae from developing. There are also nematophagous fungi that produce "traps" that engulf and kill parasitic larvae. These fungi are more delicate than other fungi, so there are rarely great numbers of them in the soil. If the soil is depleted or out of balance, other, more dominant microorganisms will replace these fungi. Research in New Zealand and the Netherlands is in progress using nematophagous fungi to determine if they can be fed to cattle or other ruminants to kill larvae in manure piles and the surrounding soil (5). This research is in its infancy and a marketable product is years away.

The amount of time that feces remain on the pasture has an effect on the number of parasite larvae that survive and mature. Anything that hastens the breakdown of the feces will lessen the number of larvae. This can include the soil organisms mentioned above, mechanical dragging of pastures, poultry or other animal disturbance and the consistency of the feces themselves.

## Effect of Ivermectin on Dung Beetles

There is concern today about the effects of ivermectin on soil organisms, especially dung beetles. Research has shown that the use of ivermectin kills dung beetle larvae for up to 45 days through residue in the manure (6, 7). Manure from livestock treated with ivermectin does not break down as fast, either. Other dewormers don't appear to have the same effect. Also, the management system has to be taken into consideration. Ivermectin under some circumstances will be no more detrimental than any other chemical dewormer. Soils with no dung beetles will not be any more adversely affected by the use of ivermectin in livestock than by other dewormers. Farmers using controlled grazing methods and working to improve the health of their soil are the ones who will be most affected by using ivermectin. One way to use ivermectin while working to improve soils is to have a sacrifice area where animals are kept until the majority of the ivermectin is excreted from them. The pour-on formulations of ivermectin affect dung beetle larvae for the least amount of time, the sustained release formulation for the longest period of time (6).

## Strategic Deworming

There will be times when chemical dewormers are the best treatment. The situation, time of year and location will help determine which chemical dewormer to use. These dewormings should be strategically carried out in order to reduce the number of times needed. There are three main classes of wormers--the benzimidazoles, such as fenbendazole or Safeguard™ (white); the imidazothiazoles, such as levamisole (yellow); and the avermectins, of which ivermectin (clear) is a member. Rotating these three classes yearly is an accepted rule for decreasing resistance buildup by the parasites themselves. It is critical to reworm three weeks later, especially with newly weaned animals. This kills those worms that were ingested and matured following the initial deworming. This has been shown to significantly reduce pasture

contamination. Strategic deworming is discussed in detail in the enclosure "Alternative Approaches to Managing Small Ruminant Gastrointestinal Nematode Parasites."

It does little good to deworm livestock and return them to the same infected pasture. Do not deworm and immediately move animals to a clean pasture. All the dead worms, with very viable eggs in them, will be passed to contaminate the pasture. Instead, deworm, hold animals in their same location for 12-24 hours, and then move them to a clean pasture. Appropriate management minimizes re-infection. Strategies discussed in the enclosures include calving or lambing on clean pasture, weaning calves and lambs to clean pasture (with cows and ewes grazing the infested pastures in the fall), and pasture rotation between cattle and sheep. There are several ways to utilize multiple animal species to control the worm population. One technique that appears to work well is dividing your farm in half, with cattle on one half and sheep on the other half. Midway through the grazing season, switch halves of the farm. Having one species of livestock follow another one will have a benefit. The different livestock species will break up manure of other species and will not avoid those areas of pastures. This will break the life cycles of the parasites because their natural host will not be present.

There are many claims of different dewormers that they will increase the weight of animals by so many pounds. It is up to the producer to determine if this increased poundage is economically justified. Animals and worms have developed together. Getting rid of all worms all the time is not essential for the health of the animal, is rarely cost effective and can actually be detrimental since the immune system of the animal is an important defense mechanism in managing parasite effects.

Make sure that your dewormer is effective. If you are concerned that it isn't, have a veterinarian check the egg count in the feces of about 15 animals before treatment. After 10

days, check the egg count again. There should be at least an 85 percent kill. You may need to consult your veterinarian about the most effective dewormers for your area. If parasites become resistant to a particular family of dewormers, then you will have to switch families. Alternating families of wormers is a good way of slowing resistance to the dewormer. Many people alternate every time they worm. Research does not recommend this. Instead, use the same dewormer for a whole year before switching. The enclosure "Is Parasite Control Possible?" discusses dewormer resistance.

To implement any type of integrated parasite control program it is essential to know when loads will be highest, such as at lambing; where the young animals stay at those highest egg production times; how pastures can be divided and how long they can be rested in order to let eggs and larvae die. If the producer has some idea of how much parasite infestation exists, this will also help in determining whether, and how often, chemical deworming should be given. Some scientists and producers say that rotationally grazed pastures do not aid in parasite control, because the rest period is usually not long enough to break the life cycles of parasites. This is true. Most pastures are rested between 21-30 days during the growing season, which is also the length of time it takes for infective stage larvae to develop. The goal then is to lower the number of infective larvae that are ingested by the animal. If even one thing can be done to lower these parasite numbers, it will help reduce the need for chemical dewormers. One such technique was demonstrated by Dr. Louis Gasbarre (8). He showed that by deworming adult dairy cattle after they have been rotated through all the farm's paddocks (which took nineteen days), all the larvae that survived the winter on the pastures were eaten by the cattle and then killed by the deworming. This deworming was done before the larvae had matured to egg-producing worms. This eliminated the need for three additional dewormings on that particular farm.

Managing the length of time animals remain on a pasture is also important to remember. This is just one other item that has to be figured in when doing pasture planning for a season. Don't let those pastures be grazed too short!

### **Alternative Dewormers**

Most alternative dewormers have not been shown by scientific research to have any effect on numbers of worms. Diatomaceous earth (DE) has been promoted by some for controlling internal and external parasites in livestock. Almost pure silica, DE is the finely ground fossilized remains of diatoms, tiny sea organisms that accumulate on the sea floor and can be mined from deposits. The diatom remains have microscopic cutting edges that are said to pierce the outer protective layer of parasitic worms and insects, causing dehydration and death. There is little scientific data on the effectiveness of DE for internal parasites, but researchers have seen a decrease in flies on animals when using DE. I have enclosed a report from The Leopold Center about a project that showed no statistical difference between the use of DE and the control group. I have talked to Dan Morrill, Sheep Extension Specialist at Iowa State, who told me that they had a hard time even getting the lambs infested with worms, which was necessary to test to the effectiveness of DE. I bring up this point to make you aware that farmers must know if their animals even have worms in order to know whether control measures are needed, are effective, or how to effectively change them.

Many producers have claimed that they have had good results with DE, but their management is usually very good. They may be giving credit to the DE when they should be giving it to themselves. Although I have nothing to back me up, I've often wondered if it isn't the minerals in the DE that provide the benefit. Worm egg count also naturally falls at the end of summer and the beginning of fall. People who are doing fecal egg counts (FEC) may be thinking the DE is lowering the egg

counts, instead of realizing that it is the natural cycle. I haven't talked to any producer who uses DE without significantly changing and then watching their management. Using DE is not just a simple substitute for a chemical dewormer. This is another problem with the scientific research that has been done on DE. Researchers have simply substituted DE for their conventional wormer and done everything else exactly the same. This is component research, whereas to really prove that DE has an effect, systems research needs to be done, using the same or similar management techniques that producers use. This type of research is much more difficult to do. If you still want to use DE, one dosage that I've seen used is ten to twenty pounds per ton of mineral supplement. Every animal must be fed a dose every day to be effective.

**...farmers must know if their animals even have worms in order to know whether control measures are needed, are effective, or how to effectively change them.**

Deworming alternatives exist in herbal and folk medicine used for centuries in other cultures. Herbs such as garlic work not by killing the worms, but by making the intestinal tract healthier. Since worms and other intestinal parasites have evolved to thrive in the unhealthy digestive tract, anything that will make that environment healthier will be detrimental to their survival. Dr. Susan Wynn (9), writing in the Journal of American Holistic Veterinary Medical Association, discusses alternative dewormers in great detail and points out that much more research needs to be done to determine the effectiveness of herbs and other natural substances traditionally used as dewormers. Her article also states that many herbs can be toxic to animals, so great care should be taken in giving them. There are veterinarians who use herbs as part of a parasite control program. The AHVMA (10) has a list of veterinarians practicing complementary and alternative medicine in every state.

## Conditions with Signs Similar to Parasitism

Keep in mind that there are other conditions that can mimic the signs of parasites. It is easy to assume that any unthrifty or thin animal with a rough hair coat or diarrhea is wormy. Internal parasites may be present, but the clinical signs are secondary or a symptom of some other, more insidious disease or condition. Any stressful condition, such as a weather extreme, can cause borderline clinical parasitism to become severe. If animals do not have enough forage or other feed in the fall so that they go into winter in good condition, this lack of condition will cause additional stress on the animal in other ways. This animal will be more apt to show extreme clinical signs of parasitism, including blood loss and death, than an animal which might have some internal parasites but is in good physical condition and is on a high plane of nutrition. In this case, poor nutrition is the cause of the animal's disease and worms are the symptom.

Fescue toxicosis is often blamed when animals are actually wormy. These two conditions can also work together, and it can be hard to determine which one is the main culprit. Fescue toxicosis is especially blamed when bringing animals from the western states. While that indeed may be a problem, the farmer needs to look at the time of year the animals have been placed on fescue, what their overall body condition is, and also check for the presence of worm eggs in the feces.

## Conclusion

There is no one thing that can be given or done to replace chemical dewormers. It will take a combination of extremely good management techniques and possibly some alternative therapies. Do not think you can just stop deworming your animals with chemical dewormers. It is something you will need to change gradually, observing and testing animals and soil, in order to monitor your progress. Alternative parasite control is an area that is receiving a lot of interest and attention. Programs and research will continue in the

pursuit of parasite control, using alternative and more management-intensive methods.

## References:

- 1) Whitlock, J.H., et al. 1943. The relationship of diet to the development of Haemonchosis in sheep. *Journal of the American Veterinary Medical Association*. January. p. 34-35.
- 2) Stear, M.J., K. Bairden, et al. 1997. How hosts control worms. *Nature*. September 4. p. 27.
- 3) Barrell, G.K., (ed.) 1997. Sustainable control of internal parasites in ruminants. *Animal Industries Workshop*. Lincoln University, Canterbury, New Zealand. June. 280 p.
- 4) Dr. Craig Reinemeyer  
Department of Comparative Medicine  
2407 River Dr.  
Knoxville, TN 37901-1071  
(423) 974-5727
- 5) Waller, P.J. and Margaret Faedo. 1996. The prospects for biological control of the free-living stages of nematode parasites of livestock. *Volume 26, No. 8/9*. p. 915-925.
- 6) Herd, R.P., et al. 1996. Persistence of ivermectin in plasma and feces following treatment of cows with ivermectin sustained-release, pour-on or injectable formulations. *International Journal for Parasitology*. Vol. 26, No. 10. p. 1087-1093.
- 7) Strong, L., et al. 1996. The effect of faecally excreted ivermectin and fenbendazole on the insect colonisation of cattle dung following the oral administration of sustained-release boluses. *Veterinary Parasitology*. Volume 62. p. 253-266.
- 8) McBride, Judy. 1998. An ounce of prevention equals pounds of milk. *Agricultural Research*. January. p.10-11.
- 9) Wynn, Susan G. 1996. Anthelmintic therapy in holistic veterinary practice. *Journal of the American Holistic Veterinary Medical Association*. February-April. p. 15-19.
- 10) American Holistic Veterinary Medical Association (AHVMA)  
2214 Old Emmorton Road  
Bel Aire, MD 21015  
(410) 569-0795

## Enclosures:

Adams, Mary. 1997. Natural product evaluated for efficiency in deworming sheep. Leopold Letter. Spring. p. 4-5.

Anon. 1996. "Medicine" plants key to worm control. CashMirror. March. p. 6.

Bowen, Joan. 1994. Economics of parasite control; more isn't necessarily better. sheep! December. p. 15.

Griffith, Charles. 1997. Forage. Ag News & Views. November. p. 1.

Hawker, Lisa Stormes. 1995. Is parasite control possible? National Lamb & Wool Grower. July. p. 28-30.

Herring, Chris. 1994. Ask the vet. The Fiberfest Magazine. Summer. p. 27-28.

Kidd, Randy. 1993. Control parasites organically? The New Farm. November-December. p. 7, 11.

Mitchell, Linda. 1996. Clean grazing for parasite control. New Farmer & Grower. November. p. 8-11.

Scarfe, A. David. 1993. Alternative approaches to managing small ruminant gastrointestinal nematode parasites. In: Proceedings of the 1993 American Dairy Goat Association National Convention. Portland, OR. p. 37-44.

---

**By Ann Wells, DVM  
NCAT Agriculture Specialist**

---

**April 1999**

THE ATTRA PROJECT IS OPERATED BY THE NATIONAL CENTER FOR APPROPRIATE TECHNOLOGY UNDER A GRANT FROM THE RURAL BUSINESS-COOPERATIVE SERVICE, U.S. DEPARTMENT OF AGRICULTURE. THESE ORGANIZATIONS DO NOT RECOMMEND OR ENDORSE PRODUCTS, COMPANIES, OR INDIVIDUALS. ATTRA IS LOCATED IN THE OZARK MOUNTAINS AT THE UNIVERSITY OF ARKANSAS IN FAYETTEVILLE AT P.O. BOX 3657, FAYETTEVILLE, AR 72702. ATTRA STAFF MEMBERS PREFER TO RECEIVE REQUESTS FOR INFORMATION ABOUT SUSTAINABLE AGRICULTURE VIA THE TOLL-FREE NUMBER 800-346-9140.

# Predator Control for Sustainable & Organic Livestock Production

LIVESTOCK TECHNICAL NOTE

*Abstract: This publication examines how to identify livestock predators and how to control them. Many species of animals can be classified as predators, but coyotes and dogs account for more than three-quarters of all livestock lost to predators. This publication focuses primarily on the control of coyotes and dogs through management practices, such as fencing and secure areas, and the use of guard animals, such as dogs, donkeys, and llamas.*

By NCAT Staff, October 2002

Portions of this publication are based on the Predator FAQ <<http://www.18james.com/rural/predator.html>>©2002 by Ronald Florence, with the permission of the author.

## Introduction

It is virtually impossible to eliminate all predators and the damage they cause to livestock, but good management can reduce this damage and still be consistent with sustainable or organic livestock production. Because every farm is different, there is no single practice or single combination of practices that will be right for every situation. Therefore, when predators strike, it is important to be aware of all options available for their control and to act at once. Writing in the Ontario(Canada) Ministry of Agriculture, Food and Rural Affairs publication *Management Practices Can Influence Predation*, Anita O'Brien says:

For managing predation, a variety of methods must be available; one method will not be effective for every producer. Most successful predator control programs use an integrated approach—combining good husbandry with effective control methods.

Prevention cannot be stressed enough, because after predators kill once they are more than likely to return and kill again. If predators have started killing sheep, it is important to stop the killing as quickly as possible. (1)

All species of livestock are susceptible to predation, especially young animals, but sheep and goats suffer most. Therefore, while the information here is applicable to all livestock, it is directed especially toward protecting sheep and goats.

## Identifying Predator Attacks

Livestock can die or disappear for many reasons—predators, disease, poisonous plants, bloat, exposure, theft, stillbirth—and even clear evidence that a predator has been feeding on a carcass is not evidence that the predator was the killer, because most preda-

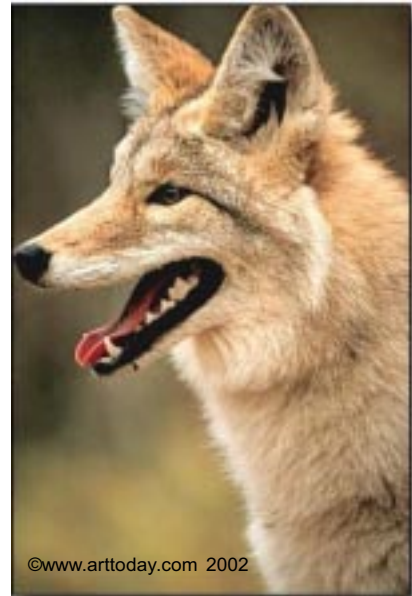

## Table of Contents

Introduction .....	1
Identifying Predator Attacks .....	1
Management Techniques to Minimize Predator Losses .....	5
Guard Animals .....	7
References .....	12
Further Resources .....	13
Appendix: Disposal of Dead Livestock .....	16

tors will scavenge on dead livestock (2). The best proof that a predator has been at work – and the best means of identifying it – is when a large animal has been attacked and is largely intact, although the disappearance of young animals may also be a sign of predator activity.

Predation can have a devastating effect not only on livestock but on the livelihood of the farmer as well. According to the National Agricultural Statistics Service (NASS) report *Sheep and Goat Predator Loss*, U.S. sheep and lamb losses to predators totaled 273,000 animals in 1999. As you can see from Table 1 below, coyotes and dogs caused more than 75 percent of those losses. This represented more than one-third of the total losses of sheep and lambs from all causes and resulted in a cost to farmers of more than \$16 million (3).

According to *Something's Been Killing My Sheep – But What? How to Differentiate Between Coyote and Dog Predation*, a publication of the Ontario Ministry of Agriculture, Food and Rural

Affairs, predation has risen rapidly during the past 10 to 15 years, causing ever-increasing losses to sheep operations. Ontario producers reported almost three times more sheep lost in 1995 (3,060) than in 1986 (1,149). The total would have been higher, the publication states, if losses to dogs – both feral and domestic – and unexplained disappearances had been included (4).

Once a carcass has begun to decompose or has been scavenged, it's often hard to determine whether the animal was killed by a predator or died of other causes. To differentiate between the two, it's necessary to examine the overall appearance of the carcass, including the condition of the coat, the eyes, ears, and feces (firm or diarrhetic), even the position of the animal in death (animals that have died of natural causes are usually found on their sides or on their chests with their legs folded under them) (5).

Although the pattern of killing typical of a predator species can sometimes help identify the problem predator, an individual's killing style can

**Table 1. Losses of Sheep and Lambs from Predators: Number of Head and Total Value, United States, 1999.**

Predator	Number of Head <i>Number</i>	% of Total Predators <i>Percent</i>	Total Value <i>1,000 Dollars</i>
Coyotes	165,800	60.7	9,637
Dogs	41,300	15.1	2,982
Mountain Lions, Cougars, or Pumas	15,600	5.7	998
Bears	7,800	2.9	555
Foxes	8,100	3	400
Eagles	10,700	3.9	522
Bobcats	12,700	4.7	650
All Other Animals	11,000	4	758
US	273,000	100	16,502

Reference NASS (4)



overlap the killing style of another species. Other types of evidence, such as tracks and feces, are sometimes necessary to correctly identify the kind of predator responsible (2).

The Wildlife Services (WS) of the USDA/Animal and Plant Health Inspection Service (APHIS) is the federal agency to contact with livestock predation problems. They work with farmers and ranchers to protect agricultural resources in a way that is practical, humane, effective, and environmentally sound. They can help you identify predators and offer remedies that will minimize the impact on wildlife (6). Each state's Wildlife Service activity report, along with the state WS contact information, is available at <<http://www.aphis.usda.gov/ws/statereportindex.html>>.

An excellent publication, *Procedures for Evaluating Predation on Livestock and Wildlife*, is located at <<http://texnat.tamu.edu/ranchref/predator/b-1429-2.htm>>. This publication provides details on many of the observations that are needed to determine whether a predator is the cause of livestock death. It also provides specific information on the typical killing patterns for most of the predator species.

*Prevention and Control of Wildlife Damage – 1994* has separate chapters on more than 90 species of wildlife that may cause damage to crops or livestock. Each of these chapters covers identification, damage-prevention, and control. The book is available at <<http://deal.unl.edu/icwdm/handbook.shtml>>. The 90 species-chapters are listed alphabetically. The book is also available on CD-ROM or in paper copy. (See **Further Resources: Books**, for ordering information.)

The 36-page Alberta Agriculture, Food and Rural Development publication *Methods of Investigating Predation of Livestock* outlines how to tell whether a predator killed an animal and how to identify the predator. (See **Further Resources: Books**, for ordering information.)

The Maryland Small Ruminant webpage "Predator and wildlife management" is a rich

source of information, with links to many different sites and publications covering all areas of predator-damage control and management. The webpage is located at <<http://www.sheepandgoat.com/predator.html>>.

## COYOTES AND DOGS AS PREDATORS

When stock is killed or missing, it is most likely that the predator responsible is either a coyote or a dog. The NASS *Sheep and Goats Predator Loss* table shown above reveals that in 1999 coyotes and dogs caused more than 75 percent of all predator losses for sheep, with losses to coyotes alone topping 60 percent. Coyotes have become a problem in almost all of the United States, Canada, and Mexico. The state Wildlife Service can verify the legal status of coyotes in your state; contact information is available at <<http://www.aphis.usda.gov/ws/statereportindex.html>>.

Most states allow coyotes to be shot or trapped at any time, if they are causing damage, but some states have different regulations or specific hunting seasons only.

In some cases, a producer may have difficulty trying to decide whether a coyote, a neighbor's

dog, or their own dog was the killer. The Ontario publication *Something's Been Killing My Sheep – But What? How to Differentiate Between Coyote and Dog Predation* lists ten criteria that can help determine the culprit. They are: time of attack; duration of attack; temperament of flock; extent of attack or kill; location of attack or carcasses; target animals; attacking behavior; feeding behavior; tracks at site; and droppings (4). The publication is available at <<http://www.gov.on.ca:80/OMAFRA/english/livestock/sheep/facts/coydog2.htm>>.

Some of the criteria used to distinguish between coyote and dog predation are:

- Coyotes tend to kill quickly, at night or early dawn, by biting sheep on the throat just behind the jaw and under the ears.



- Coyotes will generally kill only one or two animals, and only close to areas with plenty of cover to allow the coyotes to escape. Coyotes eat their kill by first feeding on the abdominal cavity.
- Coyotes are probably responsible if lambs or small animals are missing, because coyotes will take smaller animals back to their den, especially when feeding their pups.
- Dogs will attack at any time of the day or night.
- Dogs are usually poor predators, and their attacks last much longer, affecting more of the flock, so the animals are more nervous and confused after the attack.
- Dogs usually attack sheep or other livestock for the chase, not for food. Dog attacks usually cause more slashing and ripping wounds and the mutilation of legs, ears, tails, and hindquarters, on both the dead and surviving animals (5).

The 31-page Alberta book *Coyote Predation of Livestock* provides information to help producers prevent or reduce losses from coyotes. (See **Further Resources: Books**, for ordering information.)

If a dog or pack of dogs is the culprit, what can the producer do? The Ontario publication *Family Dogs Attack Sheep* cites an Australian study of 1,400 dogs that attacked livestock. In the study, the authorities used trained tracking dogs to follow the offending dogs home. The authorities found that most of the dog owners would not believe that their dogs had attacked the livestock. Most of the owners believed that their dogs were either too small, young, or friendly to commit such an act. None-the-less, the publication states:

*The researchers caught dogs from 3 months to 12 years of age, intact and sterilized dogs of both sexes, purebred and mongrel; all attacking livestock. Most of these dogs were well fed, friendly, family pets, running at large. Selective breeding has not suppressed the tendency of any breed of dog to attack and kill livestock. Animal behaviorists say it is not possible to predict whether a particular dog will attack sheep or not.*

Owners should understand the reason why a dog attacks sheep—it's all for the love of the game (7).

Dr. C. V. Ross, in his book *Sheep Production and Management*, suggests that livestock producers learn their legal rights concerning the control of dogs in their areas. He explains that there is great variation among laws concerning predatory dogs. Livestock owners "have the right to protect their property from damage, but there are all kinds of variations in the interpretation of protecting property and therein lies the basis for many bitter and costly lawsuits" (8). Livestock producers have lost cases in court when they have killed dogs on their property that were not caught in the immediate act of killing livestock.

### WOLVES AS PREDATORS

In states such as Minnesota and Wisconsin where wolves have been reintroduced, producers need to consider the increased challenge of protecting livestock from these adaptable predators. In most states where wolves have been reintroduced, livestock killed by wolves is compensated for by the state, upon presentation of evidence that it was a wolf kill. The publication *Wolves in Farm Country: A Guide for Minnesota Farmers and Ranchers Living in Wolf Territory* provides information on what to do if a wolf kill is suspected, whom to contact, and how to preserve the evidence. It is available at <<http://www.mda.state.mn.us/AMS/wolf.htm>>. The publication cautions:

*Wolves are protected under federal law. It is illegal to harm or kill a wolf, except in defense of human life. Any attempt to frighten away wolves returning to kill other animals or to feed on dead livestock must be done without harming the wolf (9).*

The Canadian Federation of Agriculture publication *Preventing Wolf Predation on Private Land* provides some specific methods to reduce wolf predation, but remember that the wolf is not protected in Canada and that hunting, trapping, and snaring are permitted there. The publication is available at <<http://www.cfa-fca.ca/english/publications/wildlife/wolf.htm>>.

## Management Techniques to Minimize Predator Losses

All management techniques have advantages and disadvantages. Some will work for one producer but not for another. It is important for producers to combine the management techniques best suited to their operations with the most effective predator control methods for their circumstances.

### FENCING

Specially constructed woven (mesh) wire or electric fencing can be useful in a management strategy for deterring predators. The USDA/APHIS publication *A Producers Guide to Preventing Predation of Livestock* states:

*The success of various types of fencing in excluding predators ranges from zero to 100 percent. Density and behavior of coyotes, terrain and vegetative conditions, availability of prey, size of pastures, season of the year, design of the fence, quality of construction, maintenance, and other factors interplay in determining how effective a fence will be. Fencing is most likely to be cost effective when the potential for predation is high, where there is a potential for a high stocking rate, or where existing fences can be electrified. Fencing is more effective when incorporated with other means of predator control (10).*

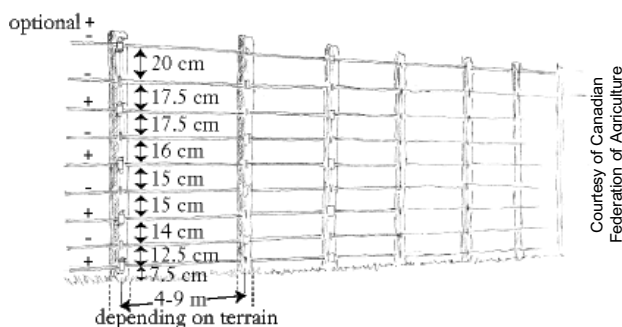

Fencing is most successful if it is strung before the predator has established a pattern of movement. If coyotes have been feeding on livestock in a pasture, the construction of a fence will probably not deter them, since they already recognize the livestock as food. The USDA/APHIS publication *A Producers Guide to Preventing Predation of Livestock* comments that “because

predator exclusion fences may restrict movement of other wild species, especially large game animals, Federal or State regulations may prohibit construction of effective fences in some areas” (10).

Building a new mesh or woven wire fence for predator management can be expensive. A properly constructed 5½- to 6-foot mesh wire fence should have horizontal spacing of less than 6 inches and vertical spacing of 2 to 3 inches. It should have barbed wire at ground level and barbed wire, electric wire, or wire overhangs on top to help deter predators that will climb or dig under fences.

Multiple strands of single-wire electric fencing can cost less than new mesh fencing. Seven or nine strands of high-tensile smooth wire, with alternating charged and grounded wires (beginning with a charged bottom wire) can help reduce predation. A Canadian predation study in the mid 1970s showed a 90 percent reduction in sheep lost to predation in pastures with electrified fences (11). Electric fences require maintenance to ensure proper livestock protection, and snow and frozen ground can greatly reduce the effectiveness of electric fencing (11).

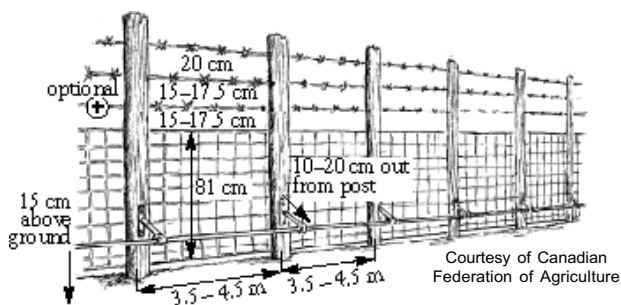

Adding electric wires at the top and electric trip wires to the bottom and middle of a mesh fence that is in good condition can help make it an effective predator barrier and is probably more cost-effective than replacement. An electric trip wire placed about 6 inches off the ground and 8 inches outside the woven wire fence will help prevent predators from digging under it. Electric wires added to the top and at various intervals along the woven wire fence will help discourage predators from climbing or jumping the fence.

Detailed information on building fences is available from the following sources:

- The Alberta publication *Protecting Livestock from Predation with Electric Fencing* at <<http://www.agric.gov.ab.ca/agdex/600/684-7.html>>
- The 47-page book *Fencing with Electricity* published by the Alberta Agriculture, Food and Rural Development Publication Office is intended to help producers choose and build the right electric fences for their operations. (See **Further Resources: Books**, for ordering information.)
- The book *...May Safely Graze: Protecting Livestock Against Predators* by Eugene Fytche has a chapter on predator control fencing. (See **Further Resources: Books**, for ordering information.)
- The article “Sheep In, Coyotes Out: High Tensile Electric Fencing” at <[http://www.suite101.com/print\\_article.cfm/9948/63040](http://www.suite101.com/print_article.cfm/9948/63040)>.
- The chapter entitled “Fencing Against Predators” from the *Sheep Production Handbook* at <<http://www.sheepusa.org/resources/predcontrol.shtml>>.
- The 1983 Oregon State University publication *Building an Electric Antipredator Fence* at <<http://eesc.orst.edu/agcomwebfile/edmat/PNW225.pdf>>.
- The Maryland Small Ruminant Webpage is an excellent source of fencing information. It also has links to many publications on fencing, as well as many fencing vendors at <<http://www.sheepandgoat.com/fencing.html>>.

### RECORD KEEPING

Accurate records provide a ready way to know when livestock is missing from a pasture. Knowing quickly that a loss has occurred helps speed the response to a predator problem. In addition, knowing the exact number and location of the losses can help to identify the predation pattern and the problem areas on the farm or ranch (1).

### NIGHT CONFINEMENT CLOSE TO RESIDENCES

Because many predators, including coyotes, are usually active between dusk and dawn, con-

fining livestock in predator-proof pens at night can reduce losses. In addition, some predators are reluctant to approach any place where humans are present. Livestock will learn to come to the secure pens when they are regularly penned at night. Additional labor and maintenance of facilities may be required (12).

### LAMBING IN SHEDS OR SECURE LOTS

Lambing in sheds or secure lots can reduce losses to predators. Shed lambing allows the producer greater access to the sheep to assist with lambing and will also provide the opportunity for lambing earlier in the season. The main disadvantages of shed lambing are the initial cost of the shed and the additional labor needed (13).

### PROMPT REMOVAL OF ALL DEAD LIVESTOCK

Dead animals attract coyotes and other scavenging predators. Unless the dead animals are removed, the predators will return to feed on them. Coyotes may depend on dead animals to remain in livestock-raising areas (12). One Canadian study found that on farms that promptly removed dead livestock, predator losses were lower than on farms where dead livestock were not removed (13). See the **Appendix** for information on various livestock disposal methods.

### USING LARGER LIVESTOCK IN ROUGHER PASTURES WITH HISTORIES OF PREDATOR PROBLEMS

Pastures with a history of predator problems should be avoided—especially during lambing. Pastures with rough terrain or dense vegetation provide good cover for predators. Placing larger animals in these pastures will usually reduce the incidence of predation (10).

### NOISE, LIGHT, AND OTHER DETERRENTS

Predators can display uncanny abilities to outwit a producer’s attempts to protect livestock. Producers may need to use more than one practice concurrently, and probably will need to vary the practices occasionally. Most predators are wary of any changes in their territory and will shy away from anything different until they become familiar with it. The following are several devices that help discourage predators.

### **Electronic Guard**

Developed by the USDA/APHIS/Wildlife Service, the Electronic Guard is a light-sensing device that is activated at dusk and de-activated at dawn. It combines a strobe light and a siren going off in random order. The random intervals help prevent predators from becoming accustomed to it. According to William Paul and Philip Gipson, authors of "Wolves," in *Prevention and Control of Wildlife Damage – 1994*, the Electronic Guard may be useful in reducing livestock predation for up to four months. They say that it is most effective in small, open pastures, around penned livestock (14). Specific information on the use of the Electronic Guard is available at <<http://www.aphis.usda.gov/oa/pubs/eguard.html>>. Producers can contact their state Wildlife Service to see whether there is an Electronic Guard to rent; contact information for state Wildlife Services is available at <<http://www.aphis.usda.gov/ws/statereportindex.html>>. The Electronic Guard costs about \$270, not including the battery. An Electronic Guard can be ordered by writing the WS Pocatello Supply Depot, 238 E. Dillon St., Pocatello, ID 83201, or by calling (208) 236-6920.

### **Night lighting**

Lighting corrals at night may serve to frighten some predators away, but may also attract roaming dogs to the stock. Lights will allow the producer to see any predators that are in the pen. Lighting doesn't usually affect the livestock, and they adapt quickly (10). In a 1977 Kansas study involving 100 Kansas sheep producers, lighting corrals at night had the most obvious effect on losses from predators. Of the 79 sheep killed by coyotes in corrals, only 3 were lost in corrals with lights (15).

### **Propane exploder**

Propane exploders produce loud explosions at random intervals. They work best when the interval is fairly short and the location is changed every couple of days. The Predator Defense Institute website publication *Controlling Coyote Damage to Livestock* says that the exploders are effective only temporarily, because coyotes become accustomed to the noise (12).

### **Bells**

Producers have put bells on sheep for years to discourage predators; however, there are no data to establish the usefulness of this practice.

Bells help to locate the sheep or to alert the producer to predator trouble in the flock (10). The Predator Defense Institute website publication *Controlling Coyote Damage to Livestock* states that "A study in Kansas found that coyotes never attacked belled sheep in a flock, perhaps because of their 'strangeness' "(12).

### **Radio**

According to the Predator Defense Institute, "Use of a tractor radio or other loud radio tuned to an all night station (especially talk radio) is at least temporarily effective at deterring coyotes" (12).

### **Parking vehicle in area of loss**

Parking a car or pickup near the area where losses are occurring may temporarily deter coyotes, especially if the vehicle is moved frequently (17).

### **Other visual and noise distractions**

Eugene L. Fytche, author of *...May Safely Graze*, cites a producer who used visual distractions around the edges of his pasture. These included large pieces of Styrofoam, wheel discs, aluminum pie plates, wind chimes, plastic oil containers filled with a variety of liquids, balloons, old clothes, and whatever came to hand. Fytche commented that the producer didn't have any losses in three years despite living in a high-risk area (16).



Courtesy of Iowa State University, Ames, Iowa

---

## **Guard Animals**

---

Dogs, donkeys, and llamas can all serve as full-time guard animals, but the effectiveness of any of them will also depend on the bonding, training, instincts, and temperament of individual animals. All guard animals require an invest-

ment of time and money, and there is no guarantee that they will be successful.

Sometimes a single guard animal will not be enough to protect the livestock. Several guard dogs may be necessary to patrol larger areas or to better protect against packs of predators. A llama and guard dog combination can be trained to work cooperatively, but donkeys or llamas will not properly bond to livestock if more than one of their own species is present with the livestock. Rotational grazing can sometimes help, because the livestock are confined to a smaller area, allowing guard animals to be more effective.

Producers should research the costs and advantages of the various guard animals, and seek advice from other producers in the area with guard animal experience. Producers need to remember that guard animals by themselves will probably not be successful without implementation of other predator control methods. No one predator control method will solve every producer's predator problem, but combining several methods can help.

The following are good sources of general information on livestock guard animals:

- The Maryland Small Ruminant webpage "Predator and wildlife management" at <<http://www.sheepandgoat.com/predator.html>>.
- The Missouri Department of Conservation publication *Using Guard Animals to Protect Livestock* at <[http://www.conservation.state.mo.us/documents/landown/wild/guard\\_animals.pdf](http://www.conservation.state.mo.us/documents/landown/wild/guard_animals.pdf)>.
- The book *...May Safely Graze: Protecting Livestock Against Predators* by Eugene Fytche, which has several chapters on different guard animals. (See **Further Resources: Books**, for ordering information.)

## GUARD DOGS

Livestock-guarding dogs originated in Europe and Asia. Most are large (80–120 pounds), mainly white breeds. Guard dogs do not herd sheep; they are full-time members of the flock. They stay with or near the flock most of the time and aggressively protect the sheep. In some instances guard dogs may injure the stock they are guarding or attack other animals, such as pets that enter their territory. They may also confront unfamiliar people (hikers, etc.) who approach the livestock. Producers using guard dogs should post signs to alert passers-by and plan to escort visitors going near the sheep (17). Neighbors should also be notified that you are using a guard dog, because a patrolling guard dog may be mistaken for a predator dog.

### Some key points for raising a guard dog are:

- Select a suitable breed and reputable breeder.
- Rear pups singly from 8 weeks of age with sheep, minimizing human contact (probably the most critical ingredient for success).
- Monitor the dog and correct undesirable behaviors.
- Encourage the dog to remain with or near the livestock.
- Ensure the dog's health and safety.
- Manage the livestock in accordance with the dog's age and experience (e.g., use smaller pastures while the dog is young and inexperienced).
- Be patient and allow plenty of time to train your dog. Remember that a guardian dog may take 2 years or more to mature. (17)

Usually, a successful guard dog is a standard guard breed that has been properly reared and trained. But sometimes, despite good breeding and training, a dog just won't guard properly. Many, but not all, of these failures trace back to improper rearing or to the dog being too old to bond with the sheep. Research and surveys indicate that only about three-fourths of guard dogs are temperamentally suited to being good guardians (17). In order to properly raise the best guard dog, the producer needs to understand what a good guard dog does, assess

the temperament of the pup, and raise it correctly.

The nearest office of the USDA/APHIS Wildlife Services (WS) should have additional information about using dogs to guard livestock. State WS contact information is available at <<http://www.aphis.usda.gov/ws/statereportindex.html>>.

The USDA/APHIS/WS has two predator prevention publications, *Livestock Guarding Dogs*

*Protecting Sheep from Predators and A Producers Guide to Preventing Predation of Livestock*, as well as a loaner video on using guardian dogs. These free publications and the video are available by contacting USDA/APHIS/LPA, Wildlife Service Publications, 4700 River Road, Unit 51, Riverdale, MD 20737, or by phone at (301) 734-7799. The publications are also available at <<http://www.aphis.usda.gov/oa/pubs/guarddog.pdf>> or <[/prodguide.pdf](#)>.

Additional information about using guardian dogs is also available by contacting any of these USDA/APHIS /WS specialists: Roger A. Woodruff (18), Jim Luchsinger (19), or Jeffrey S. Green (20).

For additional information on livestock guard dogs:

- The 1988 Oregon State University publication *Raising and Training a Livestock-guarding Dog* is available for \$1.50 (postage and shipping included) from Publications Orders, Extension & Station Communications, Oregon State University, 422 Kerr Administration, Corvallis, OR 97331-2119, (541) 737-2513, or at <<http://eesc.orst.edu/agcomwebfile/edmat/EC1238.pdf>>.
- The 2001 book *Dogs: A Startling New Understanding of Canine Origin, Behavior, and Evolution* by Raymond Coppinger and Lorna Coppinger, Scribner Publisher, ISBN #: 0-684-85530-5, has an excellent chapter on Livestock Guardian Dogs. This book is available from Amazon.com and many other bookstores.
- The C&C Farm Website, <<http://www.c-c-farms.com>>, is a good source of practical information on guard dogs. C&C Farm's Beverly Coate is the author of the book *Ain't Life Grand with a Great Pyrenees Guarding the Flock*. (See **Further Resources: Books**, for ordering information.)

## DONKEYS

Donkeys make good guard animals because they naturally hate dogs and coyotes, are not afraid of them, and like to intimidate them. Donkeys also are social animals that will associate with other species of livestock in the absence of other donkeys; however, it can take a donkey four to six weeks to fully bond with a sheep flock. Because they can eat what the sheep eat, guard

Some additional guard donkey guidelines are:

- Select donkeys from medium- to large-size stock. Do not use extremely small or miniature donkeys.
- Do not acquire a donkey that cannot be culled or sold if it fails to perform properly.
- Use jennies and geldings. Jacks are usually too aggressive.
- Test a new donkey's guarding response by challenging the donkey with a dog in a corral or small pasture.
- Use only one donkey or jenny and foal per pasture.
- Isolate guard donkeys from horses, mules, or other donkeys.
- To increase the probability of bonding, donkeys should be raised from birth or placed at weaning with livestock.
- Raise guard donkeys away from dogs. Avoid or limit the use of herding dogs around donkeys.
- Monitor the use of guard donkeys at lambing, calving, or kidding, as some may be aggressive to newborns or too possessive. Remove the guard animals for a period of time if necessary.
- Use donkeys in open pastures with no more than 200 head of sheep, goats, or cattle for best results. Large pastures, rough terrain, dense brush and too large a herd lessen the effectiveness of guard donkeys. (21)

donkeys can be low maintenance; however, it is also important to feed the donkey something at the same time the sheep are fed. This will help the donkey understand that if it stays by the flock it will not miss a meal. Do not overfeed the donkey or let it become overweight. Never feed the donkey away from the flock; you want the donkey to stay always with the flock (21). It is very important that donkeys do not receive any feed that contains Rumensin, Bovatec, urea, or other products intended only for ruminant animals, as they can be poisonous to single-stomached ani-

mals like donkeys. Donkeys need routine veterinary care, such as hoof trimming, teeth filing, and parasite management. Hoof care is very important, and all donkeys need to be trained to accept hoof trimming.

Additional information on using guard donkeys is available from the following sources:

- The Ontario publication *Guidelines for Using Donkeys as Guard Animals with Sheep* provides excellent information on many of the considerations for determining whether using guard donkeys is best for a producer's situation. It is available at <<http://www.gov.on.ca/OMAFRA/english/livestock/sheep/facts/donkey2.htm>>.
- The Alberta publication *The Donkey: Management* is a good source of general information on donkeys and is available at <<http://www.agric.gov.ab.ca/agdex/400/6700201b.html>>.
- The American Donkey and Mule Society, Inc., is a good source of information and can be contacted at PO Box 1210, Lewisville, TX 75067, by phone at (972) 219-0781, or at <<http://www.lovelongears.com>>.

## LLAMAS

Llamas are aggressive toward coyotes and dogs. When they spot a predator or intruder, most llamas give a warning call, walk or run toward the intruder, and then begin to chase, kick, and paw at it. Llamas are easy to handle, can usually be trained in a few days, and have a high success rate. Once a llama is attached to the sheep and area, the area and sheep become the llama's territory and family. The llama becomes an active leader and protector. Llamas often play with lambs. Llamas seem to bond with cattle as well as they bond with sheep and goats (21).



Courtesy of Iowa State University, Ames, Iowa

Llamas with long hair may need shearing occasionally. Llamas that have bonded with humans by bottle-feeding or excessive handling may not make good guard animals (22).

Although llamas are good guardians against single coyotes and some other predators, they (like other guard animals) can be killed by packs of coyotes or dogs, or even a single neighborhood dog that is not intimidated by the guard animal's aggressive attitude. If the llama's aggressive attitude is not sufficient to scare off the predator, the llama may become prey itself, because it is about as defenseless as the animals it is guarding. Good fencing is a must to help llamas better protect themselves, but even that may not be enough in all circumstances (23).

In a 1990-91 Iowa State University study (24), researchers interviewed 145 sheep producers throughout the United States who were using guard llamas. The study looked at the characteristics of guard llamas and at their husbandry. Some of the report's results are:

- Most introductions require only a few days or less for sheep and llama to adjust to each other.
- The average ranch uses one gelded male llama pastured with 250 to 300 sheep on 250 to 300 acres.
- Sheep and lamb losses average 26 head per year (11 percent of flock) before using guard llamas and 8 head per year (1 percent of flocks) after.
- More than half of guard llama owners report 100 percent reduction in predator losses.
- Llamas are introduced to sheep and pastured with sheep under a variety of situations.

The Iowa State report is summarized in the publication *Guard Llamas: A Part of Integrated Sheep Protection*, available for \$0.75 plus \$1 shipping from Extension Distribution Center, 119 Printing and Publications Building, Iowa State University, Ames, IA 50011-3171, by phone at (515) 294-5247 or on their website at <<http://www.extension.iastate.edu/Publications/PM1527.pdf>>.



- Multiple guard llamas are not as effective as one llama.
- Ranchers estimate an annual savings of \$1,034, and 85 percent say they would recommend guard llamas to others.
- Protectiveness of sheep and easy maintenance are the two most commonly cited advantages.
- Problems encountered include aggressiveness and attempted breeding of ewes, overprotection of flock, and sheep interference with the feeding llama.
- Overall, llamas are effective guards with high sheep producer satisfaction.

The Website Llamapaedia is another good source of general management, maintenance, and other practical information about llamas. Two Llamapaedia publications on guard llamas are: *Sheep Guarding* and *Guarding Behavior* at <http://www.llamapaedia.com/uses/guard.html> and <http://www.llamapaedia.com/behavior/guardbehav.html>.

### MULTISPECIES GRAZING

Dr. Dean M. Anderson at the USDA Jornada Experiment Range (JER) in New Mexico has been working on using bonding between cattle and sheep to create what is called a “flerd,” a bonded herd of cattle and flock of sheep for free-ranging conditions. The flerd is created by pen bonding a small group of around 7 weaned lambs of the same gender with 3 non-aggressive or non-abusive heifers or cows for about a month and a half or two months. The pen bonding process conditions the sheep to bond with the cattle and stay close to the cattle when they are foraging in the pasture, rather than forming two separate groups. When a threat appears, the bonded sheep run among the cattle and stay there until the threat is over. (When a threat appears, non-bonded sheep bunch together and stay independent of the cattle.) The number and size of the cattle apparently protects bonded sheep. The bonding seems to work only one-way, with the sheep changing their behavior, and the cattle seeming just to tolerate the presence of the sheep (25).



Pen confinement to establish bonding can be incorporated into other management strategies such as pen lambing or winter feeding. When pen bonding is initiated, it is important to have a safe area where the sheep can escape if the cattle become aggressive. During the first day of bonding, the sheep should be confined in a safe area with the cattle on the other side. After the first day the sheep should be allowed into the cattle area to begin eating and socializing together. The sheep’s location in the pen can highlight problems; sheep with abusive cattle will spend twice as much time in the safe area as sheep with non-abusive cattle. Dr. Anderson’s research suggests that penning recently weaned lambs or kids with docile, gentle cattle for a minimum of 40 to 50 consecutive day of uninterrupted confinement can result in a consistent bond. Dr. Anderson is attempting to find ways to reduce the necessary bonding time (25).

Besides predator protection, bonded flocks provide the benefits of multi-species grazing. Grazing both species together makes a better use of the forage in the pasture. Anderson recommends “sheep-proof” boundary fences but adds that “sheep-proof” internal fencing is not necessary for the flerd, because the sheep consistently remain with the cattle during both foraging and resting. Flerds are not limited to sheep and cattle. Dr. Ander-

#### Other ATTRA publications on multispecies grazing and pasture management:

- [Multispecies Grazing](#)
- [Sustainable Pasture Management](#)
- [Rotational Grazing](#)
- [Matching Livestock and Forage Resources in Controlled Grazing](#)
- [Introduction to Paddock Design & Fencing-Water Systems for Controlled Grazing](#)
- [Assessing the Pasture Soil Resource](#)
- [Nutrient Cycling in Pastures](#)

son has also bonded 5-month-old mohair kids and 100-day-old Spanish kids with cattle. Some of the Spanish kids demonstrated few flocking tendencies, but Dr. Anderson considers it possible to create a Spanish goat herd by selecting only animals that stay with the herd, and eliminating any that refuse. The mohair kids seemed to flock readily and to bond well with both the cattle and the sheep (25).

For additional information on bonding cattle, sheep, and/or goats, contact Dr. Dean M. Anderson, at USDA/ARS, MSC 3JER, New Mexico State University, PO Box 30003, Las Cruces, NM 88003-0003, or phone at (505) 646-5190.

---

## References

---

- 1) O'Brien, Anita. 1997. Management Practices Can Influence Predation. Ontario Ministry of Agriculture, Food and Rural Affairs. 2 p. <[http://www.gov.on.ca:80/OMAFRA/english/livestock/sheep/facts/info\\_mgmtpredinf.htm](http://www.gov.on.ca:80/OMAFRA/english/livestock/sheep/facts/info_mgmtpredinf.htm)>.
- 2) Main, Martin B. 2000. Interpreting the Physical Evidence of Predation on Domestic Livestock. Southwest Florida Research and Education Center. 3 p. <[http://www.imok.ufl.edu/wild/coyote/pred\\_id.htm](http://www.imok.ufl.edu/wild/coyote/pred_id.htm)>.
- 3) National Agricultural Statistics Service. 2000. Sheep and Goats Predator Loss. Agricultural Statistics Board, U. S. Department of Agriculture. p 1. <<http://usda.mannlib.cornell.edu/reports/nassr/livestock/pgg-bbsg/predan00.pdf>>.
- 4) Tapscott, Brian. 1997. Something's Been Killing My Sheep – But What? How to Differentiate Between Coyote and Dog Predation. Ontario Ministry of Agriculture, Food and Rural Affairs. 5 p. <<http://www.gov.on.ca:80/OMAFRA/english/livestock/sheep/facts/coydog2.htm>>.
- 5) Wade, Dale A., and James E. Bowns. 1997. Procedures for Evaluating Predation on Livestock and Wildlife. 15 p. <<http://texnat.tamu.edu/ranchref/predator/b-1429-2.htm>>.
- 6) Wildlife Services. No date. Protecting American livestock: An Important and Successful Federal Role. USDA/APHIS. 2 p. <<http://www.aphis.usda.gov/ws/introreports/livestock.pdf>>.
- 7) Richardson, Craig. 2001. Family Dogs Attack Sheep. Ontario Ministry of Agriculture, Food and Rural Affairs. 2 p. <<http://www.gov.on.ca:80/OMAFRA/english/livestock/sheep/facts/familydog.htm>>.
- 8) Ross, C. V. 1989. Controlling predator losses in sheep. In: Sheep Production and Management. Prentice-Hall, Inc., New Jersey. p. 388–402.
- 9) White, Blane. 2000. Wolves in Farm Country: A Guide for Minnesota Farmers and Ranchers Living in Wolf Territory. Minnesota Department of Agriculture. 5 p. <<http://www.mda.state.mn.us/AMS/wolf.htm>>.
- 10) Animal and Plant Health Inspection Service. 1994. A Producers Guide to Preventing Predation of Livestock. USDA Agriculture Information Bulletin No. 650. 14 p. <<http://www.aphis.usda.gov/oa/pubs/prodguide.pdf>>.
- 11) Anon. 1997. Protecting Livestock from Predation with Electric Fences. Alberta Agriculture, Food, and Rural Development. 5 p. <<http://www.agri.gov.ab.ca/agdex/600/684-7.html>>.
- 12) Predator Defense Institute. 1997. Controlling Coyote Damage to Livestock. 6 p. <<http://pdi.enviroweb.org/alternat.htm>>.
- 13) McAdoo, J. Kent, and Hudson A. Glimp. 2000. Sheep management as a deterrent to predation. Rangelands. June. p. 21–24.
- 14) Paul, William J., and Philip S. Gipson. 1994. Wolves. In: Prevention and Control of Wildlife Damage—1994. p. C-123–C-129.

- 15) Henderson, F. Robert, and Clifford W. Spaeth. 1980. Managing Predator Problems: Practices and Procedures for Preventing and Reducing Livestock Losses. Cooperative Extension Service. Kansas State University, Manhattan, KS. 20 p. <<http://www.oznet.ksu.edu/library/wldlf2/c620.pdf>>.
- 16) Fytche, Eugene L. 1998. ...May Safely Graze. Eugene Fytche, Almonte, Ontario. 103 p.
- 17) USDA/APHIS. 1998. Livestock Guarding Dogs Factsheet. Wildlife Services. January. 3 p. <<http://www.aphis.usda.gov/oa/pubs/gdog.html>> or </gdogs.pdf>.
- 18) Roger A Woodruff  
USDA/APHIS/WS  
720 O'Leary Street, NW  
Olympia, WA 98502  
(360) 753-9884
- 19) Jim Luchsinger  
USDA/APHIS/WS  
5949 S. 58th Street  
P.O. Box 81866  
Lincoln, NE 68501-1866  
(402) 434-2340
- 20) Jeffrey S. Green  
USDA/APHIS/WS  
12345 W. Alameda Parkway, Suite 204  
Lakewood, CO 80228  
(303) 969-6565, Extension 233
- 21) Braithwait, Jim. 1996. Using Guard Animals to Protect Livestock. Missouri Department of Conservation. 14 p. <[http://www.conservation.state.mo.us/documents/landown/wild/guard\\_animals.pdf](http://www.conservation.state.mo.us/documents/landown/wild/guard_animals.pdf)>.
- 22) International Llama Association. 1995. Guard Llamas: An Alternative for Effective Predator Management. Educational Brochure # 2. 4 p. <[http://www.internationalllama.org/html/pdf/\(2\)%20guard%20llamas.pdf](http://www.internationalllama.org/html/pdf/(2)%20guard%20llamas.pdf)>.
- 23) Castalia Llama. 2000. Llamas as Guardians – NOT! 6 p. <<http://www.rockisland.com/~castalia/guard.html>>.
- 24) Franklin, William L., and Kelly J. Powell. 1994. Guard Llamas: A part of Integrated Sheep Protection. Pm-1527 Iowa State University. 12 p. <<http://www.extension.iastate.edu/Publications/PM1527.pdf>>.
- 25) Anderson, Dean M. 1998. Pro-active livestock management – Capitalizing on Animal Behavior. Journal of Arid Land Management. p. 113-116.

---

## Further Resources

---

### WEBSITES

#### USDA/APHIS/WS

<http://www.aphis.usda.gov/ws/statereport/index.html>

Each state's Wildlife Service activity report and state WS contact information.

<http://www.aphis.usda.gov/oa/pubs/guarddog.pdf>

Publication *Livestock Guarding Dogs Protecting Sheep from Predators*.

<http://www.aphis.usda.gov/oa/pubs/prodguide.pdf>

Publication *A Producers Guide to Preventing Predation of Livestock*.

#### National Association of State Departments of Agriculture

[http://www.nasda-hq.org/nasda/nasda/member\\_information/gen\\_main.htm](http://www.nasda-hq.org/nasda/nasda/member_information/gen_main.htm)

Each state's Department of Agriculture contact information listed in a directory.

#### Maryland Small Ruminant Page

<http://www.sheepandgoat.com/predator.html>

"Predator and Wildlife Management" has links to many different sources of information and publications in all areas of predator damage control and management.

<http://www.sheepandgoat.com/fencing.html>

"Fencing" has links to many publications on fencing, as well as many fencing vendors.

**Alberta Agriculture, Food, and Rural  
Development Ministry**

<http://www.gov.on.ca:80/OMAFR/english/livestock/sheep/facts/coydog2.htm>

Publication *Something's Been Killing My Sheep – But What? How to Differentiate Between Coyote and Dog Predation.*

<http://www.agric.gov.ab.ca/agdex/600/684-7.html>

Publication *Protecting Livestock from Predation with Electric Fencing.*

<http://www.agric.gov.ab.ca/agdex/400/6700201b.html>

Publication *The Donkey: Management.*

**Ontario Ministry of Agriculture, Food and  
Rural Affairs**

<http://www.gov.on.ca/OMAFRA/english/livestock/sheep/facts/donkey2.htm>

Publication *Guidelines for Using Donkeys as Guard Animals with Sheep.*

**Canadian Federation of Agriculture**

<http://www.cfa-fca.ca/english/publications/wildlife/wolf.htm>

Publication *Preventing Wolf Predation on Private Land.*

**Iowa State University**

<http://www.extension.iastate.edu/Publications/SA8.pdf>

Publication *Composting Dead Livestock: A New Solution to an Old Problem.*

[http://www.suite101.com/print\\_article.cfm/9948/63040](http://www.suite101.com/print_article.cfm/9948/63040)

Article "Sheep In, Coyotes Out: High Tensile Electric Fencing."

<http://www.extension.iastate.edu/Publications/PM1527.pdf>

Publication *Guard Llamas: A Part of Integrated Sheep Protection.*

**Minnesota Department of Agriculture**

<http://www.mda.state.mn.us/AMS/wolf.htm>

Publication *Wolves in Farm Country: A Guide for Minnesota Farmers and Ranchers Living in Wolf Territory.*

<http://www.mda.state.mn.us/composting/compostguide.pdf>

Publication *Composting Animal Mortalities.*

**Missouri Department of Conservation**

[http://www.conservation.state.mo.us/documents/landown/wild/guard\\_animals.pdf](http://www.conservation.state.mo.us/documents/landown/wild/guard_animals.pdf)

Publication *Using Guard Animals to Protect Livestock.*

**University of Nebraska-Lincoln**

<http://deal.unl.edu/icwdm/handbook.shtml>

Book *Prevention and Control of Wildlife Damage – 1994* has separate chapters for more than 90 species of wildlife that may cause damage to crops or livestock. Each of these chapters provides identification, damage prevention, and control methods.

**Oregon State University**

<http://eesc.orst.edu/agcomwebfile/edmat/PNW225.pdf>

Publication *Building an Electric Antipredator Fence.*

<http://eesc.orst.edu/agcomwebfile/edmat/EC1238.pdf>

Publication *Raising and Training a Livestock-guarding Dog.*

**Texas A&M University**

<http://texnat.tamu.edu/ranchref/predator/b-1429-2.htm>

Publication *Procedures for Evaluating Predation on Livestock and Wildlife.*

**American Sheep Industry Association, Inc.**

<http://www.sheepusa.org/resources/predcontrol.shtml>

The book *Sheep Production Handbook* chapter entitled "Fencing Against Predators."

**American Donkey and Mule Society, Inc.**

<http://www.lovelongears.com>

Good source of general information on donkeys and guard donkeys.

### C&C Farm Website

<http://www.c-c-farms.com>

Good source of general management and great practical information on guard dogs.

### Livestock and Poultry Environmental Stewardship

[http://www.lpes.org/Lessons/Lesson51/51\\_Mortality\\_Management.html](http://www.lpes.org/Lessons/Lesson51/51_Mortality_Management.html)

Curriculum: *Lesson 51: Mortality Management* on composting dead livestock.

### Llamapaedia Website

<http://www.llamapaedia.com/uses/guard.html>

Publication *Sheep Guarding*.

<http://www.llamapaedia.com/behavior/guardbehav.html>

Publication *Guarding Behavior*.

### BOOKS

*...May Safely Graze: Protecting Livestock Against Predators*

Eugene Fytche

R.R. 1

Almonte, Ontario K0A 1A0

(613) 256-1798

Book is \$12.95 including shipping to U.S.

*Prevention and Control of Wildlife Damage Handbook – 1994*

Wildlife Damage Handbook

202 Natural Resources Hall

University of Nebraska

Lincoln, NE 68583-0810

(402) 472-2188

<http://wildlifedamage.unl.edu/>

Book is \$40 plus \$5 shipping. CD-ROM is \$40 plus \$3 shipping.

*Coyote Predation of Livestock – Agdex 684-19* for \$8 Canadian plus shipping or

*Fencing with Electricity – Agdex 724-6* for \$10 Canadian plus shipping or

*Methods of Investigating Predation of Livestock – Agdex 684-14* for \$8 Canadian plus shipping

Alberta Agriculture, Food and Rural Development Publication Office

(780) 427-0391

<http://www.agric.gov.ab.ca/agdex/000/orderin.html>

Visa and MasterCard orders only

*Ain't Life Grand with a Great Pyrenees Guarding the Flock*

C&C Farms

Route 3, Box 6815

Stigler, OK 74462

(918) 967-4871

[http://www.c-c-farms.com/book\\_order\\_pg.html](http://www.c-c-farms.com/book_order_pg.html)

Book is \$23.95 including postage to U.S.

By NCAT Staff

Edited by Paul Williams

Formatted by Gail Hardy

October 2002

IP196

The electronic version of **Predator Control for Sustainable & Organic Livestock Production** is located at:

HTML

<http://www.attra.ncat.org/attra-pub/predator.html>

PDF

<http://www.attra.ncat.org/attra-pub/PDF/predator.pdf>

## Appendix: Disposal of Dead Livestock

Regulations for disposal of livestock mortalities vary from state to state. Most states require timely disposal of mortalities, usually within 24 to 48 hours. A state's Department of Agriculture is usually in charge of regulations concerning the allowable methods of disposal, including incineration, burying, rendering, and/or composting. Producers should contact their local Extension Agent or their Department of Agriculture (Department of Health in Arkansas) for specific regulations and requirements. The National Association of State Departments of Agriculture has each state's contact information listed in a directory located at

<[http://www.nasda-hq.org/nasda/nasda/member\\_information/gen\\_main.htm](http://www.nasda-hq.org/nasda/nasda/member_information/gen_main.htm)>.

Incineration of the carcass is one disposal method. Incinerators can be expensive to buy and operate, and their capacity is generally limited to smaller animals. Some incinerators may generate air pollution and objectionable odors. Incinerators are not very practical for small or mid-size livestock producers, if other disposal methods are available.

Burial is a common practice and is generally regulated by the state. The livestock carcass usually needs to be buried 4 to 8 feet deep, and the possible problem of contamination leaching into the ground water needs to be considered. Handling animal mortalities by burial in the winter with the ground frozen can also pose problems. Scavengers can uncover improperly buried mortalities.

Renderers' pickup services vary greatly from one area to another. Renderer pickup, if available, may be costly and be limited to certain quantities and/or species (sheep and goats are usually not picked up because of concerns about scrapie infection) (1).

Composting livestock carcasses may also be regulated by the state; some states do not allow sheep or goat composting because of concerns about scrapie. If composting is allowed, producers should consider it because composting is cost effective, environmentally sound, and relatively easy. Composting dead animals is achieved by layering the carcasses and the organic waste amendments according to a prescribed plan and not mixing the materials until the composting has finished and the dead animals are fully decomposed (longer time for larger carcasses). Compost piles that are properly constructed and correctly covered with compost mixed to capture odors will not attract scavengers. However, fencing should be used around compost piles to keep out predators and dogs.

The Natural Resource, Agriculture and Engineering Service (NRAES) has two excellent publications on composting that provide specific mortality composting guidelines. They are *On-Farm Composting Handbook*, NRAES-54 for \$25 plus postage, and the *Field Guide to On-Farm Composting*, NRAES-114 for \$14 plus postage. They can be ordered at (607) 255-7654 or at <<http://www.nraes.org>>.

Other sources of information on composting livestock carcasses are:

- The publication *Composting Animal Mortalities* at <<http://www.mda.state.mn.us/composting/compostguide.pdf>>
- The website *Livestock and Poultry Environmental Stewardship Curriculum: Lesson 51: Mortality Management* at <[http://www.lpes.org/Lessons/Lesson51/51\\_Mortality\\_Management.html](http://www.lpes.org/Lessons/Lesson51/51_Mortality_Management.html)>
- The publication *Composting dead livestock: A new solution to an old problem* at <<http://www.extension.iastate.edu/Publications/SA8.pdf>>

**Reference:** 1) Stanford, K., et al. 2000. Composting as a means of disposal of sheep mortalities. *Compost Science and Utilization*. Spring. p. 13-146.

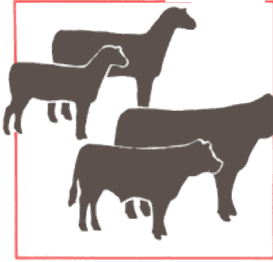

# ANIMAL SCIENCE FACTS

PUBLICATION NUMBER

ANS 00-606MG

## Extension Animal Husbandry

Department of Animal Science

### BASIC MEAT GOAT FACTS

Jean-Marie Luginbuhl

*Extension Meat Goat Specialist*

#### Reproductive Aspects

##### **Female**

- Age of puberty 7-10 months
- Breeding weight 60-75% of adult weight
- Estrous cycle
  - Length 18-22 days
  - Duration 12-36 hours
  - Signs Tail wagging, mounting, bleating
- Ovulation 12 to 36 hrs from onset of standing heat
- Gestation length 146-155 days
- Breeding season August-January
- Seasonal anestrous February-July
- Buck effect on estrous Positive

##### **Male**

- Age of puberty 4-8 months
- Breeding age 8-10 months
- Breeding season All year
- Breeding ratio 1 buck : 20 to 30 does

#### Physiological Data

- Temperature 101.7-104.5 F
- Heart rate 70-80/minute
- Respiration rate 12-15/minute
- Ruminal movements 1-1.5 /minute

#### Rules for Goat Health

- Provide proper housing
- Practice good sanitation
- Provide adequate nutrition
- Provide clean water
- Observe how much feed (hay, minerals, concentrate) is left over
- Observe your animals daily
- Observe the feces of your animals

*Reviewed by: Michael J. Yoder and Roger L. McCraw, Department of Animal Science, North Carolina State University*

Distributed in furtherance of the Acts of Congress of May 8 and June 30, 1914. Employment and program opportunities are offered to all people regardless of race, color, national origin, sex, age, or handicap. North Carolina State University, North Carolina A&T State University, U.S. Department of Agriculture, and local governments cooperating.



**North Carolina Cooperative Extension Service**

NORTH CAROLINA STATE UNIVERSITY  
COLLEGE OF AGRICULTURE & LIFE SCIENCES

- Clean pastures and exercise lots
- Become familiar with the common diseases
- Investigate the source of strange smells
- Use your veterinarian for diagnosis

### **A Healthy Goat**

- Eats well
- Chews its cud
- Has a shiny coat
- Has strong legs and feet
- Is sociable
- Has bright and clear eyes

### **Signs of Illness**

- |                                  |                               |
|----------------------------------|-------------------------------|
| ◦ Off feed, off water            | Diarrhea                      |
| ◦ No sign of cud chewing         | Runny eyes                    |
| ◦ Standing apart from group      | Limping                       |
| ◦ Rough hair coat                | Hair falling out              |
| ◦ Abnormal temperature           | Swelling on any part of body  |
| ◦ Heavy mucous in nose and mouth | Pale mucosa of eyes and mouth |

### **Purchased Animals**

Upon arrival on farm

- ***Isolate animals for a month***
  - Vaccinate
  - Deworm
  - Test for certain diseases (check with your veterinarian)
  - Coccidiosis control program
  - Identification tag
  - Other

### **Herd Health Practices**

#### ***Vaccination program***

If possible always weigh animals prior to vaccination to **1) calculate and inject the correct dosage of the vaccine and 2) assess body condition**

**Enterotoxemia and tetanus** - *Clostridium perfringens* types C, D + Tetanus Toxoid in one vaccine

- Adult males - Once a year
- Breeding females - Once a year (4 to 6 weeks before kidding) or twice a year:  
- 4 to 6 wk before breeding, then 4 to 6 wk before kidding

Kids - Week 8, then booster on week 12

#### ***Deworming program***

If possible, always weigh animals prior to deworming to **1) calculate and inject or drench the correct dosage of the dewormer and 2) assess body condition**. Underdosing of goats because of failure to weigh the animals or because of underestimating their live weight is a very common but costly mistake because this may lead to faster parasite resistance to dewormers. Therefore, determine the dose according to the heaviest animal in the group. On the other hand, overdosing of certain dewormers can cause health problems. If deworming animals before kidding, make sure that the dewormer used is safe for pregnant does.



- Adults -2 to 3 weeks prior to breeding
  - Avoid early pregnancy (first 20 to 60 days)
  - 2 to 3 weeks prior to kidding or at kidding
  - According to climate and worm loads
  - Strategic deworming**: aimed at worms that are dormant in the goat during the winter. Deworm with **fenbendazole** (Panacur or Safeguard), **albendazole** (Valbazen), **oxfendazole** (Synanthic) or **ivermectin** (Ivomec). Winter deworming prior to the spring grass flush has proven effective in controlling worm burdens during the warm weather transmission season. **Oxfendazole** should **NOT** be used in pregnant goats.
  
- Kids -Day 30
  - Day 60
  - According to climate and worm loads
  - Strategic deworming**

During periods of warm and wet weather, it is advisable to take fecal samples **immediately prior to deworming, and again 10 days after deworming**, to determine fecal egg counts and the effectiveness of the dewormer

#### ***Coccidiosis control***

Coccidiosis usually strikes young animals during periods of stress such as weaning. Level of control depends on the level of infestation

- o **At weaning**
  - Coccidiostat drench and/or
  - Coccidiostat in water tank (4 ounces in 25 gallons of water)
- o **At other times (if necessary)**
  - Mineral with Bovatec
  - Decoquinate in feed

#### **Kid Health Practice**

- o At birth
  - o Dip navel in iodine
  - o Kids should ingest 10% of their live weight in colostrum during first 12 to 24 hours of life.
  - o Colostrum should be ingested or bottle-fed (in case of weak kids) as soon as kids have a suckling reflex. In cases of extremely weak kids, they should be tube-fed. It is very important to make sure that the tube is inserted into the esophagus (you should be able to see the tube go down as it is inserted). The producer must be certain that all newborn kids get colostrum soon after birth (within the first hour after birth, and certainly within the first 6 hours) because the percentage of antibodies found in colostrum decreases rapidly after parturition.

#### **Castration**

- o Elastrator (method of choice: bloodless, less pain)
 

***The question is: why castrate if you will sell your buck kids for meat at 4 to 5 months of age? However, if not castrated, buck kids should be separated from doe kids at weaning, otherwise some unplanned breeding may occur.***

#### **Flushing**

##### ***Feeding strategy to increase ovulation rate***

- o Starting **3-4 weeks before the breeding season, and throughout the breeding season**, increase the plane of nutrition of does to be bred. Overly conditioned and fat does will not respond to flushing.
  - Switch does to high quality pasture or

- Supplement does with 1/2 lb cracked corn or 1/2 lb whole cottonseed/head/day

**After Breeding**

***To insure proper embryo development***

- o During the **first month of pregnancy**
  - Keep the plane of nutrition similar to that of flushing period

**Important Production Traits**

- |   |                               |
|---|-------------------------------|
| o Adaptability                              | Reproduction                  |
| - Ability to survive in given environment   | - Conception rate             |
| - Ability to reproduce in given environment | - Kidding or prolificacy rate |
| - Is a lowly heritable trait                | - Non-seasonality             |
| o Growth rate                               | Carcass characteristics       |
| - Pre-weaning gain                          | - Dressing percent            |
| - Post-weaning gain                         | - Lean:fat:bone               |
|   | - Muscle distribution         |

**Body Condition Score**

- o To monitor and fine tune nutrition program
- o To "head off" parasite problem
- o Visual evaluation is not adequate, has to touch and feel animal
- o Areas to be monitored
 

- Tail head	- Ribs
- Pins	- Hocks
- Edge of loin	- Shoulder
- Back bone	- Longissimus dorsi
- o Scale
 

- Thin	1 to 3
- Moderate	4 to 6
- Fat	7 to 9
- o Recommendations
  - End of pregnancy 5 to 6
  - Start of breeding season 5 to 6
  - Animals should never have a body condition score of 1 to 3
  - Pregnant does should not have a body condition score of 7 or above toward the end of pregnancy because of the risk of pregnancy toxemia
  - A body condition score of 5 to 6 at kidding should not drop off too quickly during early lactation

**Fencing**

***Perimeter Fence***

- o **Smooth electrified wire**
  - o At least 42 inches tall
    - 6 to 8 inches near the ground
    - 8 to 12 inches at the top strands
    - Example (inches from the ground): 6 - 14 - 22 - 32 - 42 - (52)

***Perimeter Fence***

- o **Woven wire (6" X 6")**

- Effective
  - Costs at least twice as much as 5 strands of smooth electrified wire
  - Horned goats can get caught
  - Place an electric wire offset about 9 inches from the woven wire fence and about 12 to 15 inches from the ground
  - Reduces control of forage growth at fence line
- **Woven wire (6" X 12")**
    - Effective
    - Cheaper
    - Horned goats usually do not get caught

### ***Interior Fences***

- Two to three strands of wires (braided or tape) with tread-in posts
- Electronet

### **Grazing Management**

In a pasture situation, goats are “top down” grazers. They start to eat seedheads or the top of the canopy and progressively take the forage down. This behavior results in uniform grazing. Goats do not like to graze close to the ground. Grazing goats have been observed to **1)** select grass over clover, **2)** prefer browse over herbaceous plants, **3)** graze along fence lines before grazing the center of a pasture, **4)** refuse to graze forage that has been trampled and soiled. These observations have been put to use in the grazing management of goats: it is preferable to give them a daily allowance of forage and to move the fence accordingly rather than to let them roam freely in a large pasture. This type of management, called control grazing, was developed in Europe and is implemented very successfully in New Zealand and numerous other parts of the world. Control grazing results in better animal performance, higher stocking rates, and increased pasture productivity.

### **So, You Want to Get in The Goat Business**

#### ***Are you really, really ready?***

- Are your fences, pens, chutes goat proof
- Is your grazing land adequate
- Do you have sufficient supplemental feed on hand
- Is your predator controller in place
- In your medicine cabinet, do you have
 

- Dewormers	- Vaccines
- Iodine	- Antibiotic ointment
- Insecticidal powder	- Thermometer
- Stomach tube	- Hoof trimmers
- Do you know the address and phone number of your county extension office?
- Do you the names of your county extension livestock, forage, and 4-H agents?
- Have you discussed your new venture with your local veterinarian?
- Have you alerted your next door neighbors to the possibility of excessive noises, exotic odors, sexual activity during the breeding season, animals getting out, and allayed their fears of the spreading of diseases?



# ANIMAL SCIENCE FACTS

PUBLICATION NUMBER

## Extension Animal Husbandry

ANS 00-605MG

Department of Animal Science

### MONITORING THE BODY CONDITION OF MEAT GOATS: A Key to Successful Management

**Jean-Marie Luginbuhl**  
*Extension Meat Goat Specialist*

**Matthew H. Poore**  
*Extension Animal Husbandry Specialist*

**As the breeding season approaches,** producers should be concerned with the body condition of their breeding does. Goats should not be allowed to become too thin or too fat. Reproductive failure can result if does are under or over conditioned at the time of breeding. Clinical symptoms of over or under conditioned does may include: low twinning and low weaning rates, pregnancy toxemia and dystocia.

The term body condition refers to the fleshiness of an animal. Because the greatest potential for goats is to graze them with beef cattle, we have devised a 1 to 9 - point graduated scale, adapted from the beef system used in North Carolina. In this graduated scale, thin is 1 to 3, moderate is 4 to 6 and fat is 7 to 9. In most situations, goats should be in the range of 4 to 7 (Table 1). Scores of 1 to 3 indicate that goats are too thin, and scores of 8 to 9 are almost never seen in goats. The ideal body condition score (BCS) just before the breeding season is between a 5 and a 6 to maximize the number of kids born. Simply looking at a goat and assigning it a BCS

can easily be misleading. Rather, animals should be handled physically. The easiest areas to feel and touch to determine the body condition of an animal are the ribs, on either side of the spine, by running a hand over those areas and pressing down with a few fingers (Figure 1). In doing so, one is able to determine the amount of fat covering the ribs. In general, does in good condition (BCS = 5 or 6) will have a fat thickness of not more than .05 to .08 inches over the loin and .03 to .05 inches over the backbone. In well conditioned goats, the backbone does not protrude and is flush with the loin. Other areas to monitor are the shoulders, the tail head, the pins, the hooks, the edge of the loins and the backbone. Does in good condition (BCS = 5 or 6) have a smooth look and the ribs are not very visible. The backbone and edges of the loins are felt with pressure, but they are smooth and round and feel spongy to the touch. Some to significant fat cover is felt over the eye muscle. Does in poor condition (BCS = 4 or lower) look angular, the ribs are visible and the backbone and edges of the loins are sharp and easily felt. None to slight fat cover is felt over the eye muscle. Practice makes perfect, thus use your animals to get a feel for it. An easy way to start is to select a few animals that are over conditioned and some others that are thin in order to get a feel for extreme BCS. Then introduce a small group of animals and compare their BCS to the animals having extreme BCS. Producers should develop an eye and a touch for the condition of their animals and strive to maintain a moderate amount of condition on their goats. When body condition starts to decrease, it is a sign that

*Reviewed by: Michael J. Yoder and Kevin J. Fozeboom, Department of Animal Science, North Carolina State University*

Distributed in furtherance of the Acts of Congress of May 8 and June 30, 1914. Employment and program opportunities are offered to all people regardless of race, color, national origin, sex, age, or handicap. North Carolina State University, North Carolina A&T State University, U.S. Department of Agriculture, and local governments cooperating.



**North Carolina  
Cooperative Extension Service**

NORTH CAROLINA STATE UNIVERSITY  
COLLEGE OF AGRICULTURE & LIFE SCIENCES

supplemental feed is needed or that animals should be moved to a higher quality pasture. Waiting until goats become thin to start improving their feeding regime may lead to large production losses and will increase feed costs.

One should also be concerned with the body condition of the breeding bucks. If bucks are overfed and become too fat (BCS = 7 or higher), they may have no desire to breed does. Conversely, bucks that are thin (BCS = 4 or lower) at the start of the breeding season may not have sufficient stamina to breed all the does. Because of the increased activity and decreased feed intake during the breeding season, breeding bucks will most probably lose weight. Therefore, they need to be in good body condition (BCS = 6) and physical shape before the season starts.

**Pregnant does** should not have a BCS of 7 or above toward the end of pregnancy because of the risk of pregnancy toxemia (ketosis) or dystocia. In addition, a BCS of 5 to 6 at kidding should not drop off too quickly during lactation.

**Body condition score is also used to determine whether flushing will be of benefit to breeding does.** Flushing means increasing the level of feed

offered to breeding does, mostly energy, starting about one month prior to the introduction of the bucks, to increase body weight, ovulation rate and hopefully litter size. Increasing the level of energy offered to does should continue throughout the breeding season and for approximately 30 to 40 days after removing the bucks for adequate implantation of the fetuses in the uterus. Does in extremely good body condition (BCS = 7) will not tend to respond to flushing. On the other hand, does that are in relatively poor condition (BCS = 4 or lower) as a result of poor feed quality and supply, high worm loads, late kidding of twins or triplets, will respond favorably to flushing by improving their body condition.

Flushing can be accomplished by moving breeding does to a lush nutritious pasture 3 to 4 weeks prior to the introduction of the bucks. This cost-effective flushing method is underutilized in the Southeast where forage is abundant. Another method is feeding ½ lb/day of a high energy supplement. Corn is the grain of choice for flushing; whole cottonseed is another low cost, high energy and also high protein supplement. The goal being to increase the intake and body weight, breeding does should be grouped according to their body condition.

## SUMMARY - BODY CONDITION

To monitor and fine tune nutrition program

To "head off" parasite problem

Visual evaluation is not adequate, has to touch and feel animal

Areas to be monitored

- |                |                     |
|----------------|---------------------|
| - Tail head    | - Ribs              |
| - Pins         | - Hocks             |
| - Edge of loin | - Shoulder          |
| - Back bone    | - Longissimus dorsi |

Scale

- |          |        |
|----------|--------|
| Thin     | 1 to 3 |
| Moderate | 4 to 6 |
| Fat      | 7 to 9 |

Recommendations

- End of pregnancy 5 to 6
- Start of breeding season 5 to 6
- Animals should never have a BCS of 1 to 3
- Pregnant does should not have a BCS of 7 or above toward the end of pregnancy because of the risk of pregnancy toxemia (ketosis) and dystocia
- A BCS of 5 to 6 at kidding should not drop off too quickly during lactation

**TABLE 1. BODY CONDITION SCORING CHART**

**BCS 1** Extremely thin and weak, near death.

**BCS 2** Extremely thin but not weak.

**BCS 3** Very thin. All ribs visible. Spinous processes prominent and very sharp. No fat cover felt with some muscle wasting.

**BCS 4** Slightly thin. Most ribs visible. Spinous processes sharp. Individual processes can be easily felt. Slight fat cover can be felt over the eye muscle.

**BCS 5** Moderate. Spinous processes felt but are smooth. Some fat cover felt over eye muscle.

**BCS 6** Good. Smooth look with ribs not very visible. Spinous processes smooth and round. Individual processes very smooth, felt with considerable pressure. Significant fat cover felt over eye muscle.

**BCS 7** Fat. Ribs not visible, spinous process felt under firm pressure. Considerable fat felt over eye muscle.

**BCS 8** Obese. Animal is very fat with spinous processes difficult to feel. Ribs can not be felt. Animal has blocky obese appearance

**BCS 9** Extremely obese. Similar to an eight but more exaggerated. Animal has deep patchy fat over entire body.

**FIGURE 1. AREAS TO BE MONITORED FOR FAT COVER**

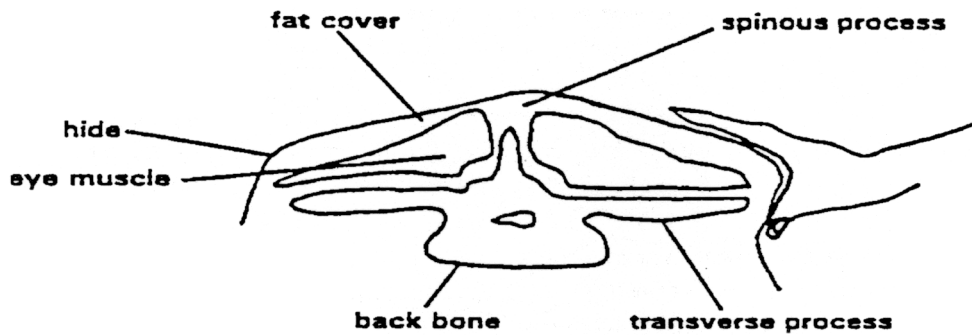
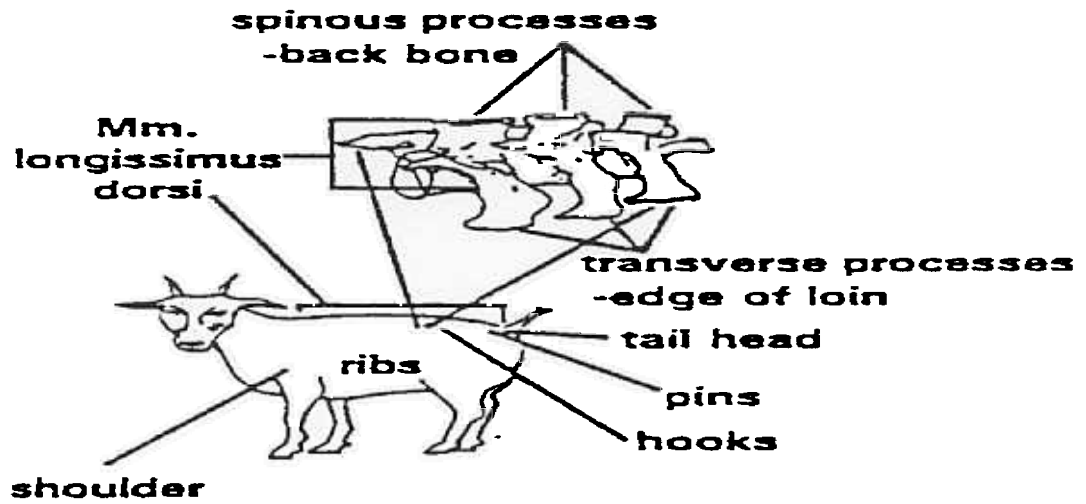



# ANIMAL SCIENCE FACTS

PUBLICATION NUMBER

## Extension Animal Husbandry

ANS 00-602MG

Department of Animal Science

### PREPARING MEAT GOATS FOR THE BREEDING SEASON

**Jean-Marie Luginbuhl**  
*Extension Meat Goat Specialist*

Breeding is a very important aspect of any meat goat operation. But, preparing the breeding does and buck(s) for the breeding season could have a large influence on the outcome and the profitability of the operation.

#### Will Body Condition Influence Breeding Success ?

As the breeding season approaches, producers should be concerned with the body condition of their breeding does. Goats should not be allowed to become too thin or too fat (Refer to ANS 00-605MG: Monitoring the body condition of meat goats: A key to successful management). Failure in reproduction, low twinning rates and low weaning rates will result if does are too thin. Overly fat does can suffer from pregnancy toxemia (ketosis) or dystocia, but fat does are rarely a problem.

The term body condition refers to the fleshiness of an animal. Simply looking at a goat and assigning it a body condition score (BCS) can easily be misleading. Rather, does should be handled physically. The easiest areas to feel and touch to determine the body condition of an animal are over the ribs, on either side of the

spine, by running a hand over those areas and pressing down with a few fingers. In doing so, one is able to determine the amount of fat covering the ribs. In general, does in good condition (BCS = 5 or 6) will have a fat thickness of not more than .05 to .08 inches over the loin and .03 to .05 inches over the backbone. In well conditioned goats, the backbone does not protrude and is flush with the loin. Other areas to monitor are the shoulders, the tail head, the pins, the hooks, the edge of the loins and the backbone. Does in good condition (BCS = 5 or 6) have a smooth look and the ribs are not very visible. The backbone and edges of the loins are felt with pressure, but they are smooth and round and feel spongy to the touch. Some to significant fat cover is felt over the eye muscle. Does that are in relatively poor condition (BCS = 4 or lower) look angular, the ribs are visible and the backbone and edges of the loins are sharp and easily felt. None to slight fat cover is felt over the eye muscle. Practice makes perfect, thus use your animals to get a feel for it. An easy way to start is to select a few animals that are over conditioned and some others that are thin in order to get a feel for extreme body condition. Then, introduce a small group of animals and compare their body to the animals having extreme body condition. Producers should develop an eye and a touch for the condition of their animals and strive to maintain a moderate amount of condition on their goats. The ideal BCS just before the breeding season is between a 5 and a 6 to maximize the number of kids born.

One should also be concerned with the

*Reviewed by: Roger L. McCraw and Scott Whisnant, Department of Animal Science, North Carolina State University*

Distributed in furtherance of the Acts of Congress of May 8 and June 30, 1914. Employment and program opportunities are offered to all people regardless of race, color, national origin, sex, age, or handicap. North Carolina State University, North Carolina A&T State University, U.S. Department of Agriculture, and local governments cooperating.



**North Carolina  
Cooperative Extension Service**

NORTH CAROLINA STATE UNIVERSITY  
COLLEGE OF AGRICULTURE & LIFE SCIENCES



body condition of the breeding bucks. If bucks are overfed and become too fat (BCS = 7 or higher), they may have no desire to breed does. Conversely, bucks that are thin (BCS = 4 or lower) at the start of the breeding season may not have sufficient stamina to breed all the does. Because of the increased activity and decreased feed intake during the breeding season, breeding bucks will most probably lose weight. Therefore, they need to be in good body condition (BCS = 6) and physical shape before the season starts.

**Body condition is also used to determine whether flushing will be of benefit to breeding does.**

Flushing means increasing the level of feed offered to breeding does, mostly energy, starting about one month prior to the introduction of the bucks. By increasing the amount of feed offered, does will put on weight. This in turn will signal to the body that the doe can afford to raise several kids, and ovulation rate and litter size will increase. Increased level of energy offered to does should continue throughout the breeding season and for approximately 30 to 40 days after removing the bucks for adequate implantation of the fetuses in the uterus. Does in extremely good body condition (BCS = 7) will tend not to respond to flushing. On the other hand, does that are in relatively poor condition (BSC = 4 or lower) as a result of poor feed quality and supply, high worm loads, late kidding of twins or triplets, will respond favorably to flushing by improving their body condition. Flushing can be accomplished by moving breeding does to a lush nutritious pasture 3 to 4 weeks prior to the introduction of the bucks. This cost-effective flushing method or "feed flush" or "green flush" is underutilized in the Southeast where forage is abundant. Another method is feeding ½ lb/day of a high energy supplement. Corn is the grain of choice for flushing; whole cottonseed is another low cost, high energy and also high protein supplement. The goal being to increase intake and body weight, breeding does should be grouped according to their body condition.

**What Other Measures Will Increase Reproductive Performance?**

Several other important measures will affect breeding indirectly, such as trimming feet, the grouping of animals, deworming, using the "buck effect" to synchronize does, and vaccination.

**1. Trimming feet**

Feet and legs should be examined closely for sores, overgrown hooves and sources of strange smells that could be associated with infections or foot rot. Start trimming the feet of animals several weeks before the breeding season to make sure that they will be in top shape during that period of increased activity. The buck in particular will cover a lot of territory. A lame buck will cover does only sporadically, or might give up altogether. Similarly, limping does may not let bucks breed them.

**2. Grouping of animals**

Goats are very social animals and should be grouped together several weeks before the breeding season so that the pecking order of the animals may be established. Forming groups just prior to the breeding season will disrupt the pecking order of the animals. The fighting that will ensue to establish a new pecking order within the newly-formed groups will be a source of stress and will influence reproductive performance.

Young does should have reached approximately 70 to 75% of their estimated mature body weight to be bred successfully without adversely affecting their mature size.

**3. Deworming**

Deworming breeding does and buck(s) before the start of the breeding season is an important management tool. If flushing is planned, it is advisable to deworm prior to flushing. Wormy does will not increase their body condition during the flushing period and therefore flushing may not increase ovulation rate. In addition, wormy does will not breed well, or may not breed at all, or may conceive and abort later.

**4. The "buck effect"**

Segregating does from bucks is crucial in the development of sound breeding programs that should be paralleled with feed resources and market demands. The best approach to separate does from bucks is to develop a secure buck pasture. The buck pasture should be far enough from the breeding doe herd, otherwise bucks will attempt to go through fences to breed does in estrus.

In goats, estrus can be induced with the strategic exposure of anestrus does to intact males. This response is dependent on the depth of seasonal

anestrus and associated with a first ovulation in two to three days after the introduction of the buck. The first ovulation is usually silent and of low fertility. The second ovulation five days later is accompanied by a fertile estrus. The response to the male effect is influenced by the sexual aggressiveness of the buck, the intensity of the stimulation and the body condition of the does. Immediate contact results in a greater response than fence-line contact or intermittent contact. The pheromones responsible to induce estrus are present in buck hair, but not in urine, and are not associated with buck odor during the breeding season.

### **5. Vaccination**

Although some producers have had no problems so far without implementing a vaccination program, it is recommended that goats be vaccinated against overeating disease (enterotoxemia) and tetanus. For twice a year vaccination, breeding does should be vaccinated before the start of the breeding season and 4 to 6 weeks before kidding. If vaccinated once a year, it is preferable to vaccinate breeding does prior to kidding because some immunity will be passed on to the newborns. The choice of vaccines is the following:

- 1. *Clostridium Perfringens* Types C and D +Tetanus Toxoid** in one vaccine, against overeating disease and tetanus. This vaccine is labeled for goats.
- 2. Multivalent clostridial vaccine (8-way vaccine).** One example of a multiway clostridial vaccine, labeled for sheep, is Covexin8. Covexin8 is more reactive and may cause a higher incidence of adverse reaction at the injection site. Covexin8 may be used in herds which have had problems with blackleg and malignant edema (gas gangrene). Although blackleg

and malignant edema are common and costly infections in sheep and cattle, they are uncommon in goats.

### **Is the Buck Ready for Breeding?**

Bucks may be easily overlooked but one cannot assume that they are reproductively sound. A buck that was sound one year may not be the next. The results of using a reproductively unsound buck will be reduced kidding rates and profits. It is a good idea to watch bucks for normal urination and also for signs of sexual behavior as the breeding season approaches. For a more thorough breeding evaluation, sit the buck on its rump. With the back of its head resting on your thigh, examine the testes. They should be roughly the same size, fairly firm to the touch and devoid of lumps. The presence of testicular abnormalities could indicate that the buck is unsound for breeding. Next, examine the sheath (also called the prepuce) and the penis if you can protrude it. It requires some experience to push the prepuce down to reveal the penis. The penis should be checked for sores and the pizzle (the thin worm-like process at the end of the penis) should not be hard anywhere. The presence of hard, small lumps could be an indication of urinary stones (a condition also called urinary calculi). A buck suspected of reproductive problems, whether in the testes or any part of the penis, should be examined by a veterinarian before allowing it to breed does.

### **How Long Should the Breeding Season Last?**

During the breeding season, does and bucks should be joined for 40 to 45 days, which is the length of time necessary for breeding does to complete two estrus cycles. A ratio of 20 to 30 does per buck is recommended for best breeding results.

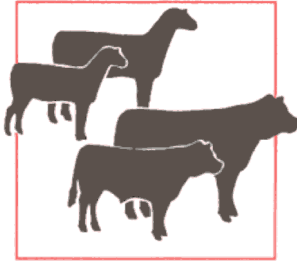

# ANIMAL SCIENCE FACTS

PUBLICATION NUMBER

ANS 00-607MG

## Extension Animal Husbandry

Department of Animal Science

### HEAT DETECTION AND BREEDING IN MEAT GOATS

**Jean-Marie Luginbuhl**  
*Extension Meat Goat Specialist*

Although goats are considered seasonal breeders and in our region the breeding season generally extends from September to February, many exceptions occur. Dairy breeds such as the Saanen and Alpine are temperate climate Swiss dairy breeds and the prototype of seasonal breeders. Nevertheless, even in these two breeds, some does have the ability to breed out of season and as early as July if housed or grazed with a buck. The Nubian breed, originally derived from African stock, is probably the least seasonal dairy type goat. Meat type goats such as the Pygmy and the Myotonic (Tennessee Stiffleg) also differ in their ability to breed out of season. The same appears to be true for the Boer breed. The Pygmy is a true year around breeder in the USA, whereas the Myotonic is moderately seasonal. Factors playing an important role in the ability of goats to breed out of season include plane of nutrition, body condition, and stimulus from a buck.

Segregating does from bucks is crucial in the development of sound breeding programs that should be paralleled with feed resources and market demands. The best approach to separate does from bucks is to develop a secure buck pasture. The buck pasture should be far enough from the breeding doe herd, otherwise

bucks will attempt to go through fences to breed does in estrus.

In goats, estrus can be induced with the strategic exposure of anestrus does to intact males. This response is dependent on the depth of seasonal anestrus and associated with a first ovulation in two to three days after the introduction of the buck. The first ovulation is usually silent and of low fertility. The second ovulation five days later is accompanied by a fertile estrus. The response to the male effect is influenced by the sexual aggressiveness of the buck, the intensity of the stimulation and the body condition of the does. Immediate contact results in a greater response than fence-line contact or intermittent contact. The pheromones responsible to induce estrus are present in buck hair, but not in urine, and are not associated with buck odor during the breeding season.

During the breeding season, goats come into heat or estrus approximately every 18 to 22 days. A transitional period occurs at the beginning and end of the breeding season during which short heat cycles without ovulation have been documented. Short estrous cycles of less than 12 days and very often of 5 to 7 days may occur, especially in young does. Mature does that have shortened estrous cycles in the middle of the breeding season should be considered abnormal.

For successful breeding, does and bucks should be joined for 40 to 45 days, which is the length of time necessary for does to complete two estrous cycles. A ratio of 20

Distributed in furtherance of the Acts of Congress of May 8 and June 30, 1914. Employment and program opportunities are offered to all people regardless of race, color, national origin, sex, age, or handicap. North Carolina State University, North Carolina A&T State University, U.S. Department of Agriculture, and local governments cooperating.

*Reviewed by: Steven P. Washburn and Scott Whisnant, Department of Animal Science, North Carolina State University, and Stephan Wildeus, Virginia State University*



**North Carolina  
Cooperative Extension Service**

NORTH CAROLINA STATE UNIVERSITY  
COLLEGE OF AGRICULTURE & LIFE SCIENCES

to 30 does per buck is recommended for best breeding results.

Does in heat become vocal and some bleat very loudly as if in pain. Constant tail wagging from side to side is another sign of heat. In addition, the vulva will appear slightly swollen and reddened and the area around the tail may look wet and dirty because of vaginal discharge. Other signs of heat include decreased appetite and an increased frequency of urination. Does in heat also are easily identified if a buck is nearby. They will pace restlessly along their enclosure for a way to get to the buck or stand close to the fence. Finally, a doe in heat may mount another doe as if she were a buck or let another doe mount her.

In spite of all these signs, it is still sometimes possible to miss heat. In general, people experiencing most trouble in detecting estrus usually have only one or two goats. In some instances, it may be very useful to run a teaser (vasectomized) buck with the does to detect estrus. A vasectomized buck is rendered infertile through surgery by cutting the tubes carrying the sperm from the testes to the penis. However, his libido and interest in mating still remains. An intersex animal exhibiting female genitalia with an enlarged clitoris but demonstrating male mating behavior has been used to detect estrus at the NCSU Meat Goat and Forage Educational Unit. Animals used to detect estrus can be fitted with a harness containing a crayon that will mark the females in heat when they are mounted. If the herd is checked twice a day, marked females can then be separated and mated to the appropriate stud male.

The duration of estrus varies from 12 to as long as 48 hours. Within that duration standing heat (the period the doe stands firmly when a buck attempts to mount)

lasts approximately 24 hours. For some unknown reasons, some does in estrus will not stand to be bred by certain bucks. Ovulation usually occurs 12 to 36 hours from the onset of standing heat. At the beginning of estrus, the vaginal discharge is clear and colorless. It becomes progressively whiter and more opaque towards the end of standing heat.

Does reach puberty and may be ready to breed at 7 to 10 months of age. However, does should not be bred until they reach 60 to 75% of their expected mature weight, because otherwise their growth may be stunted. Therefore, in deciding when to breed does, producers should consider their age and size, but also when they were bred last, and their body condition. Season should also be taken into consideration because kids born during the hot spring or summer months do not thrive and experience more health problems than kids born during cooler parts of the year. Meat goats are often bred every 8 months. Such frequent breeding requires excellent management, good nutrition, and breeds that effectively breed out of season. However, breeding once a year will result in increased litter size per breeding and over the lifetime of the doe, give the doe more time to nurse kids when they grow the fastest, and will give the doe time to rest to replenish its body condition for the next breeding season.

Additional related information can be found in the following Animal Science Facts:

- ANS 00-602MG: PREPARING MEAT GOATS FOR THE BREEDING SEASON.
- ANS 00-605MG: MONITORING THE BODY CONDITION OF MEAT GOATS: A Key to Successful Management.
- ANS 00-606MG: BASIC MEAT GOAT FACTS.

# Small Ruminant Info Sheet

by [SUSAN SCHOENIAN](#)

## The internal parasites that affect small ruminants

Genus and species	Common name	Site	Life cycle	Conditions	Clinical signs	Significance	
<i>Haemonchus contortis</i>	Barberpole worm Wire worm	Abomasum	Direct	18 to 21 days	warm, moist summer rainfall	Blood loss (Anemia) Edema ("Bottle Jaw") Weakness Wool breaks Sudden death	Major problem in warm, moist climates
( <i>Ostertagia</i> ) <i>Teladorsagia circumcincta</i>	Medium or brown stomach worm	Abomasum	Direct	20 days	cool, moist	Production loss Lack of appetite Diarrhea Weight loss Decreased wool production	Usually secondary to Barber Pole worm in warm, moist climates
<i>Trichostrongylus</i>	Bankrupt worm Hair worm	Abomasum Small intestine	Direct	< 21 days	warm, moist	Black scours Reduced appetite Production loss Occasional death	Usually secondary to Barber Pole worm in warm, moist climates
<i>Strongyloides papillosus</i>	Common threadworm	Small intestine	Direct	7-9 days	warm, moist	Weight loss Diarrhea Inflammation between toes	Minor
<i>Cooperia</i> spp.	small intestinal worm	Small intestine	Direct	20 days	cool, wet winter rainfall	Loss of appetite Diarrhea Weight loss Decreased wool growth	Minor Additive
<i>Nematodirus</i> spp.	threadneck worm	Small intestine	Direct	20 days	cool, wet	Usually sub-clinical Diarrhea, loss of appetite, weight loss	Usually secondary to Barber Pole worm in warm, moist climates
<i>Dictyocaulus filaria</i> <i>Muellerius capillaris</i>	lungworm hair lungworm	Trachea and bronchi	Direct Indirect (snails, slugs)	5 weeks	cool, wet	Usually no signs of infection. Coughing, fluid in lungs if disease is severe. Pneumonia	Minor

<i>Moniezia</i> spp.	tapeworm	Small intestine	Indirect (pasture mites)	6 weeks	wet	Heavy infestations may result in unthriftiness and GI disturbances	Mostly non-pathogenic
<i>Eimeria</i> spp.	coccidia	Small intestine	Direct	< 21 days	cool, wet conditions Overcrowding	Liquid diarrhea Off feed, depression Death	Major
<i>Trichuris ovis</i>	whipworm	Caecum	Direct	6-12 weeks	Dry	Diarrhea	Of little consequence Additive
<i>Bunostomum phlebotomum</i>	hookworm	Small intestine	Direct	1-2 months	warm, moist	Unthriftiness Diarrhea Blood loss Anemia Sore feet	Minor
<i>Oesophagostomum</i>	nodule worm	Large intestine	Direct	5 weeks	cool, wet winter rainfall	Damage lining of small intestines	Minor
<i>Paralaphostrongylus tenius</i>	meningeal worm deer worm brain worm	central nervous system	Indirect (snails, slugs)	82-91 days	cool, wet	Hindquarter weakness Ataxia Paralysis Blindness	Varies
<i>Fasciola hepatica</i>	liver fluke	Liver	Indirect (snails, slugs)	8-12 weeks	wet areas	production losses Death Organ condemnation	Varies

Created or last updated 17-Jul-2010 by [Susan Schoenian](#).

©Copyright 2005-2010. [Maryland Small Ruminant Page](#)

Susan Schoenian is a Sheep & Goat Specialist at the University of Maryland's Western Maryland Research & Education Center and an affiliated faculty member of the Department of Animal and Avian Sciences at the University of Maryland College Park. Susan has been with University of Maryland Extension (UME) since 1988. Previously, she served as Farm Management Specialist for Maryland's nine Eastern Shore counties and as a county agent in Wicomico County. Her first professional job was as Sheep Specialist for the West Virginia Department of Agriculture. Susan earned her B.S. and M.S. degrees in Animal Science from Virginia Tech and Montana State University, respectively. She raises registered and commercial Katahdin sheep on a small farm in Clear Spring, Maryland.

# Drugs (Anthelmintics) Commonly Used to Control Gastro-intestinal Parasites (worms) in Small Ruminants in the U.S.

Not all drugs are approved by the Food and Drug Administration (FDA) for use in small ruminants. The mention of non-approved products is for informational purposes only. The use of non-approved drugs constitutes extra label drug use and can only be done legally under the advice of a licensed veterinarian. Sheep and/or goats may require different dosages and withdrawal periods than are listed on the label.

Trade Name	Drug Ingredient	Chemical family	Approved Species	Specificity	Labeled Dosage for approved species	Withdrawal time for approved species
<a href="#"><u>Cydectin® 0.5% pour-on for cattle</u></a>	Moxidectin	ML <sup>1</sup>	beef cattle non-lactating dairy cattle	roundworms lungworms external parasites	5 ml/110 lbs. topical	cattle: 0 days slaughter
<a href="#"><u>Cydectin® 1% injectable</u></a>	Moxidectin	ML	beef cattle	roundworms lungworms external parasites	1 ml/110 lbs.	cattle: 21 days slaughter
<a href="#"><u>Cydectin® oral drench for sheep 0.1%</u></a>	Moxidectin	ML	sheep Not for use in lactating dairy sheep	roundworms lungworms external parasites	1 ml/11 lbs. by mouth or 1 ml/5 kg	sheep: 7 days slaughter
<a href="#"><u>Dectomax® injectable 1%</u></a>	Doramectin	ML	beef cattle swine	roundworms lungworms external parasites	1 ml/110 lbs. (cattle) 1 ml/110 lbs (swine) Sub Q or IM	cattle: 35 days slaughter swine: 24 days slaughter
<a href="#"><u>Dectomax® pour-on for cattle 0.5%</u></a>	Doramectin	ML	cattle	roundworms lungworms external parasites	5 ml/110 lbs. topical	cattle: 45 days slaughter
<a href="#"><u>Ivomec® Eprinex pour-on</u></a>	Eprinomectin	ML	cattle	roundworms lungworms external parasites	5 ml/110 lbs. topical	cattle: 0 days slaughter
<a href="#"><u>Ivomec® pour-on for cattle</u></a>	Ivermectin	ML	beef cattle	roundworms lungworms external parasites	1 ml/22 lbs. topical	cattle: 48 days slaughter
<a href="#"><u>Ivomec Plus Injection</u></a>	Clorsulon Ivermectin	ML	beef cattle	roundworms lungworms external parasites Adult liver flukes	1 ml/110 lbs. SQ	cattle: 49 days slaughter

<a href="#"><u>Ivomec® injectable 1%</u></a>	Ivermectin	ML	beef cattle swine	roundworms lungworms external parasites	1 ml/110 lbs cattle. 1 ml/75 lbs. swine Sub-Q	cattle: 35 days slaughter swine: 18 days slaughter
<a href="#"><u>Ivomec® sheep drench 0.08%</u></a> <a href="#"><u>Primectin™ Drench</u></a>	Ivermectin	ML	sheep	roundworms lungworms external parasites	3 ml/26 lbs. by mouth	sheep: 11 days slaughter
<a href="#"><u>Rumatel® Medicated Premix</u></a>	Morantel Tartrate	NIC <sup>2</sup>	cattle goats	mature roundworms	1/10 lb./100 lbs.	cattle: 14 days goats: 30 days
<a href="#"><u>Prohibit Drench Powder</u></a>	Levamisole Hydrochloride	NIC	cattle sheep	roundworms intestinal worms lungworms	Depends on dilution	cattle: 2 days sheep: 3 days
<a href="#"><u>Quest® 2% equine oral gel</u></a>	Moxidectin	ML	horses ponies	roundworms lungworms external parasites	0.4 mg/2.2 lbs.	not for horses intended for food
<a href="#"><u>Safeguard® Panacur® liquid 10%</u></a>	Fenbendazole	BZD <sup>3</sup>	cattle non- lactating goats	roundworms lungworms tapeworms	2.3 ml/100 lbs. by mouth	cattle: 8 days slaughter 0 milk withdrawal goats: 6 days slaughter
<a href="#"><u>Safeguard® Panacur® paste</u></a>	Fenbendazole	BZD	cattle horses	roundworms lungworms tapeworms	2.3 mg/lb. by mouth	cattle: 8 days slaughter
<a href="#"><u>Strongid® paste Banminth®-P Paste</u></a>	Pyrantel Pamoate	NIC	horses ponies	mature roundworms	2.27 mg/lb. by mouth	not for horses intended for food
<a href="#"><u>Synanthic® drench 9.06%</u></a>	Oxfendazole	BZD	beef cattle non- lactating dairy	roundworms lungworms tapeworms	2.5 ml/110 lbs. by mouth	cattle: 7 days slaughter
<a href="#"><u>Tramisol/Levasole® drench</u></a>	Levamisole	NIC	sheep cattle	roundworms intestinal worms lungworms	1 oz./100 lbs. 1 ml/50 lbs. by mouth	sheep: 3 days slaughter
<a href="#"><u>Tramisol/Levasole® injectable for cattle 13.65%</u></a>	Levamisole	NIC	beef cattle	roundworms lungworms	2 ml/100 lbs. Sub-Q	cattle: 7 days
<a href="#"><u>Tramisol/Levasole® boluses/oblets</u></a>	Levamisole	NIC	sheep	roundworms lungworms	1 bolus/50 lbs. by mouth	sheep: 3 days slaughter
<a href="#"><u>Valbazan® drench 11.36%</u></a>	Albendazole	BZD	cattle sheep	roundworms lungworms tapeworms adult liver fluke	3 ml/ 100 lbs. oral <b>restricted use during pregnancy</b>	sheep: 7 days slaughter
<a href="#"><u>Zimecterin® Gold Paste</u></a>	Praziquantel Ivermectin	ML	horses ponies	roundworms lungworms tapeworms external parasites	1 tube/1250 lbs. oral	not for horses intended for food



<a href="#">Zimecterin-EZ® paste</a>	Ivermectin	ML	horses ponies	roundworms lungworms external parasites	1 tube/1250 lbs. oral	not for horses intended for food
--	------------	----	------------------	--	--------------------------	-------------------------------------

**Chemical families:** <sup>1</sup>ML - macrolytic lactone; <sup>2</sup>NIC - Nicotinic agonists; <sup>3</sup>BZD - benzimidizoles.  
To learn more read: [Understanding anthelmintics](#).

Source: [Animal Drugs @ FDA](#)

Last revised: 17-Jul-2010 by [Susan Schoenian](#).

©Copyright 2004-2010. [Maryland Small Ruminant Page](#).



<http://www.sheepandgoat.com/articles/antheltable.html>

Accessed 8/20/10

**Ray M. Kaplan, DVM, PhD**  
**College of Veterinary Medicine**  
**University of Georgia**

**James E. Miller DVM PhD**  
**School of Veterinary Medicine**  
**Louisiana State University**

***Modified McMaster Egg Counting For Quantitation of Nematode Eggs.***

Fecal worm egg examination methods are based on the principle of differential density. In other words, parasite eggs sink in water, but they will float in various chemical solutions that are more dense than water (technically, they have a higher specific gravity) because the eggs are lighter than the fluid used as a floatation solution. The most inexpensive and easiest floatation solution to make is using table salt. One quart of floatation solution is sufficient for about 30 McMaster examinations.

The first step is to collect freshly passed feces that are uncontaminated by soil or bedding. The best way is to use a rubber glove and extract feces directly from the rectum. Alternatively, a feces can be picked up off the ground if done soon after deposited. The collection container should be labeled with the name (number) of the animal and the date of collection. Fresh samples work best, but accurate results can be obtained if the sample is kept refrigerated during the interim. If samples are not refrigerated the eggs will hatch within 12 to 24 hrs. Once hatched, they cannot be counted.

**Materials:**

Compound microscope

Scale

Saturated sodium chloride (table salt)\*

50 ml centrifuge tube with screw cap. Note: tube should be marked with ml increments.

Tongue depressor

Pipet (1 ml syringe or eye dropper works well)

McMasters egg counting slide\*\*

Paper towels

A fresh fecal sample should be collected and kept refrigerated until tested

\*Saturated Sodium Chloride:

Table salt        1 pound box

Tap water        3 quarts

Heat in pan with stirring until boiling, then let cool at room temp. The solution will look cloudy and some material will precipitate - this is OK. Pour clear part of solution into a dispensing container of some kind.

Store at room temperature. Do not refrigerate as additional solute will precipitate.

Note: Fecal floatation solutions are also commercially available, but are significantly more expensive than using this recipe (although not high dollar).

\*\*To order this slide, contact:

Chalex Corporation  
5004 228th Ave. S.E.  
Issaquah, WA 98029-9224  
Phone (425) 391-1169  
FAX (425) 391-6669  
E-mail: [chalexcorp@att.net](mailto:chalexcorp@att.net)  
Web site: [www.vetslides.com](http://www.vetslides.com)

Eddy Krecek  
Focal Point  
Phone (869) 468 6036 or  
(869) 466 6036  
[krecek@icon.co.za](mailto:krecek@icon.co.za)  
[www.mcmaster.co.za](http://www.mcmaster.co.za)

## Procedure:

1. Weigh out 2 grams of feces into a 50 ml centrifuge tube and fill to 30 ml with salt solution.
  - a. It is recommended to purchase a small scale and weigh feces, but if you do not have a scale you can still get a close estimation by putting 28 ml of salt solution into a 50 ml centrifuge tube first, and then adding feces until a volume of 30 ml is achieved.
2. Pour off approximately 25 ml of the salt solution into another small container keeping feces in the tube (can use tongue depressor).
3. Let soak for a few minutes and mix (soft feces) or break up (fecal pellets) with a tongue blade. .
4. Add back about ½ of the salt solution and mix well, breaking up any remaining feces as best as possible.
5. Add back the remaining salt solution and screw the cap back onto the tube.
6. Shake tube vigorously for about 1 minute to disrupt any remaining feces as much as possible.
7. Set tube aside for a few minutes to let bubbles dissipate.
8. Wet McMaster chamber with water and dry top and bottom on paper towels.
9. Rock (don't shake) tube several times to thoroughly mix solution without causing large air bubbles to form.
10. Immediately pipet (using 1 ml syringe or eye dropper) a sample of the suspension and fill both sides of counting chamber. Work quickly. If it takes more than a few seconds to load the first chamber, then mix fecal solution again and refill pipet before loading the second chamber.
11. Let stand for 1-2 minutes to allow eggs to float to top.
12. Count all eggs inside of grid areas (greater than 2 of egg inside grid) using low power (10x) objective. Focus on the top layer, which contains the very small air bubbles (small black circles, if numerous large air bubbles are visible, remove the fluid and refill).
13. Count only trichostrongyle/strongyle eggs (oval shaped, ~ 80-90 microns long). Do not count strongyloides (oval, ~ 50 microns long), tapeworm eggs (triangular/D-shaped) or coccidia (various sizes). Notations are made as to the presence of other species, but only the trichostrongyle/strongyle eggs are counted.
14. Once filled, the chambers can sit for no longer than 60 min before counting without causing problems. Longer than this and drying/crystal formation may begin.
15. Total egg count (both chambers) x 50 = EPG (eggs per gram).
  - a. Note: This is a dilution technique and theoretically this ratio of feces to flotation solution will not detect infections with less than 50 eggs per gram of feces (1 egg seen on slide), so it is not very accurate for samples with low numbers of eggs. On a practical level this is not important because from a clinical standpoint, slight differences in results when egg counts are low do not matter.

## Notes:

Fairly soon after counting is complete thoroughly rinse out the McMaster chamber with warm running water. Doing so will keep the chamber clean and ready it to be used again. If fecal solution dries in the chamber do not soak in soapy water for long periods as this will cause the chamber to become cloudy. If the chamber gets dirty, soak for only a few minutes in water containing dish soap and then rinse completely with tap water. This is one method for performing a McMaster fecal egg count. Other different but similar protocols are routinely used in many labs, so you may see a slightly different procedure recommended elsewhere. The important thing is to use the same procedure each time.

# FAMACHA<sup>©</sup>

## Information Guide

Originally compiled by the Faculty of Veterinary Science, University of Pretoria, the Onderstepoort Veterinary Institute, the Worm Workshop of the South African Veterinary Association, and Intervet South Africa, with the support of the Food and Agriculture Organization of the United Nations, the National Wool Growers' Association and the National and Provincial Departments of Agriculture in South Africa.

Modified by Dr. Ray M. Kaplan and Dr. James E. Miller within the framework of USDA SARE grant # LS02-143 to address use of FAMACHA<sup>®</sup> in the United States

### IMPORTANT NOTE FOR ALL USERS OF FAMACHA<sup>®</sup>:

- To properly implement FAMACHA<sup>®</sup>, it is essential for all users to: (1) obtain practical hands-on instruction in the use of FAMACHA<sup>®</sup>; (2) be sure they understand the information supplied; and (3) read and carefully follow all the instructions in this guide.

### WARNING:

- As this Information Guide is used in circumstances outside the compilers' and distributors' control, users must undertake to use it at their own risk. The compilers and distributors, and/or any of their employees do not accept liability for any damage or loss suffered by any person as a result of or arising from the use of this guide.

### WHY THE FAMACHA<sup>®</sup> SYSTEM WAS DEVELOPED:

- *Haemonchus contortus* (barber's pole worm) is usually the biggest disease problem of sheep and goats throughout the warm regions of the world, particularly in the subtropical and tropical areas. Major production losses and deaths can arise where the worm is not adequately controlled.
- Due to overuse of dewormers over many years, resistance to these dewormers is an ever increasing problem. On many farms in many countries, there is resistance to all the groups of deworming drugs and the viability of sheep and goat farming is threatened. No one can rely on the excessive use of drugs alone to control this parasite in the future.
- While most sheep and goats (especially the adults) are able to withstand the unfavorable effects of *Haemonchus*, a small minority cannot. In the past, treatment strategies were designed for the minority of animals that did not have the ability to withstand infection.
- Selectively deworming only those animals that require treatment greatly decreases the development of resistance because the eggs produced by the few resistant worms that survive treatment will be greatly diluted by all the eggs produced by the animals that did not receive treatment. In contrast, where all animals are treated and moved to parasite-"safe", or "clean" pasture, only resistant worms that survive treatment will produce all the eggs that form the next generation of worms.
- Both resistance (the ability to prevent or suppress infection) and resilience (the ability to withstand the effects of parasites) have been shown to be moderately heritable. This means that sheep and goats can be either culled or selected for these traits.
- Once sheep and goats that are unable to cope with existing worm challenge infections are identified, they can be targeted for special attention without the whole herd or flock having to be treated. In the long term, by culling animals that are repeatedly identified as unable to cope with moderate worm burdens, a more resistant and resilient flock, genetically suited to the environment can be bred.

## **CLINICAL DIAGNOSIS OF ANEMIA: PRINCIPLE ON WHICH FAMACHA<sup>®</sup> IS BASED:**

Blood consists of a clear, fluid part (called plasma) and a cellular part (mainly red blood cells). The proportion of red cells to plasma determines whether the animal is healthy or unhealthy. This proportion can be measured in a laboratory (called PCV or hematocrit), but with training and practice can also be estimated fairly accurately by assessing the color of the mucous membranes of (especially) the eyes. As *Haemonchus* are blood suckers, the effects of a heavy parasite burden in non-resilient animal will therefore be evident as a low ratio of red cells to plasma. This is seen in the mucous membranes of the eyes as a visible paleness generally known as anemia. By monitoring anemia, resilient and susceptible animals can be identified.

## **USES AND ADVANTAGES:**

- A significant drop in the amount and frequency of deworming can be expected for the majority of the herd or flock, which will reduce the amount of money spent on drugs.
- Because fewer animals are treated, the development of resistance in worm populations will be slowed down.
- In the long term, elimination of non-resilient animals will allow for the breeding of better adapted animals.
- There will probably only be a small to moderate number of sheep or goats that need to be treated at each examination.
- These animals can be treated before the symptoms and effects of anemia become too severe, if the flock is examined regularly.
- Individual animals that repeatedly fail to cope with *Haemonchus* in spite of an effectively designed control program can be identified and eliminated from the herd or flock.
- Animals that escaped treatment or were underdosed or improperly drenched (e.g. owing to faulty drenching syringe), can be identified before severe problems occur.
- If an ineffective dewormer for *Haemonchus* is used, this will become apparent because many anemic sheep are seen after treatment. However, if an effective dewormer is used, pale mucous membranes should become noticeably redder in color within a week or so, provided protein intake is sufficient and body condition is adequate.
- If there is a severe build-up of infective larvae on the pasture, an early warning of the impending danger can be a sudden increase in the number of anemic animals.
- Paddocks, pens, and pastures that repeatedly present problems can be identified and appropriate action taken.
- The process of inspecting the eyes is quick and can readily be integrated with other activities like vaccination, weighing, condition scoring or counting. In South Africa it is reported that up to 500 sheep can be inspected per hour with good facilities and practice.
- Because animals are examined frequently, other unrelated problems are quickly discovered.
- The technique is very easy and sufficiently reliable once learned under the guidance of a competent instructor.
- Animals become tamer and easier to handle.

## **PRECAUTIONS AND POTENTIAL PROBLEMS:**

- The FAMACHA<sup>®</sup> system should be used only after it has been fully explained and demonstrated by properly trained instructors.
- Only *Haemonchus* infection can be monitored by this technique.

- **FAMACHA<sup>®</sup>** is only a component of a good management program for *Haemonchus* and cannot be used on its own. A good, integrated control program using smart drenching principles must still be used.
- Other worms can also be important. *Trichostrongylus* (bankruptworm) is found in sheep and goats throughout the US and *Teladorsagia* (brown stomach worm) is common in the northern parts of the US. A program for controlling these and other worms may be needed as well. If either of these worms are the primary problem and *Haemonchus* is only present in low to moderate numbers, then FAMACHA<sup>®</sup> may fail to provide a sound basis for treatment decisions.
- Herd or flock fecal egg counts should be monitored on a periodic basis.
- Animals should be monitored regularly (at least every 2-3 weeks during the *Haemonchus* transmission season, and possibly as often as weekly at the peak of the worm season).
- Animals should always be scored with the help of the chart, not from memory.
- Kids/lambs and pregnant or lactating does/ewes are more susceptible and need special attention.
- *Haemonchus* is by far the most important cause of anemia in goats and sheep; however, there are other causes of anemia that could cause confusion. Some examples are:
  - Hookworms (very uncommon in the US)
  - Liver fluke (most likely only a problem in the Gulf Coast and Northwestern States)
  - External parasites
  - Blood parasites (very uncommon in the US)
  - Bacterial and viral infections
  - Nutritional deficiencies
- On the other hand, certain conditions can make the eye's membranes appear redder than expected and thus mask the presence of anemia. Some examples are:
  - Hot and/or dusty conditions which irritate the eyes
  - Driving animals a long distance with no rest period afterwards
  - Any fever
  - Infectious eye diseases
  - Diseases associated with blood circulatory failure
- With FAMACHA<sup>®</sup>, animals are allowed to become anemic prior to being treated. Therefore, *it is critical to use an effective dewormer*. Drug resistance to all available dewormers is becoming quite common. Therefore, testing to determine which drugs are effective against the worms on your farm should be done before applying the FAMACHA<sup>®</sup> system.
  - Available tests for resistance include the fecal egg count reduction test which is performed on the farm by your veterinarian, and the DrenchRite<sup>®</sup> test, which is performed in a laboratory from a fresh fecal sample that is mailed to the lab.
- Protect the card from light when not in use and replace the card after 1 year of use.

## **PRACTICAL USE OF THE FAMACHA<sup>®</sup> SYSTEM:**

- Beginning in spring or several weeks prior to lambing/kidding, examination of the herd or flock using FAMACHA<sup>®</sup> should be made every 2-3 weeks by properly trained persons.
- During high worm transmission periods (warm wet weather), it may be necessary to monitor the flock more often, even on a weekly basis.
- The FAMACHA<sup>®</sup> guide should always be used on inspections. Do not rely on memory from previous examinations.

- Treatment can be safely withheld from adult animals until they score as 4s or 5s provided that animals are in good body condition and good overall general health, are examined frequently (e.g., every 2-3 weeks) and good husbandry is used to identify animals in need of treatment (e.g., unthrifty, lagging behind, bottle jaw) between FAMACHA<sup>®</sup> examinations. It is advisable to treat animals scored as 3s if any of these conditions are not met.
- Lambs and kids have comparatively small blood volumes and can progress rapidly from moderate to severe anemia. Ewes and does have decreased immunity to worms starting approximately 2 weeks before lambing/kidding and extending through the lactation period (called periparturient period). These animals should always be treated if scored as 3s.
- If 5-10% or more of the herd or flock is found to be anemic (categories 4 and 5) at any examination, it may be advisable to dose all animals scored in categories 3-5 and change pastures if available. Animals scored as 3 should also be treated when potential outbreaks of disease from *Haemonchus* are expected. Such periods of significant *Haemonchus* challenge appear to be heralded by a rapid downward trend in the number of 1s and a reciprocal increase in the number of 2s and 3s. Consult your veterinarian if in doubt.
- The essential decision to be taken at each examination is which animals are to be treated, and which are not. Assignment to precise categories is less important. It is better to err on the side of treatment if you are unsure.
- All animals treated with dewormer should be marked or identified in some permanent way (ear tags, ear marks, notches, cable ties, etc.) unless individual animal records are kept. It is recommended that animals permanently marked should also be given a temporary mark so that the same animal is not unfairly marked permanently at the next examination.
- Animals needing two doses more than the herd or flock's average could be considered for culling, while those needing three or more extra doses should definitely be culled.
- The proportions of the flock in each category (from 1 to 5) can easily be recorded by counting off each animal in the FAMACHA<sup>®</sup> block histogram (anemia score sheet) provided.
- If the herd or flock is very large, a random sample of 50 animals can be checked. If the combined percentage of categories 1 and 2 exceeds 80% (preferably 90%) and there are no category 4 and 5 sheep in the sample, it is unlikely that there is danger in not checking the whole flock. However, if any sheep are scored as 4 or 5, or the 3 category exceeds 10 – 20%, it would be safer to examine all the animals.
- Examine especially those animals that lag behind the herd or flock whether or not it is time for a scheduled FAMACHA<sup>®</sup> examination. These late-comers may be suffering from the effects of anemia.
- Always check animals for “bottle jaw” (presence of a soft swelling under the jaw). All animals with bottle jaw, whether they appear anemic or not, must be treated.

## Inquiries and Orders:

### US ONLY

Dr. Ray M. Kaplan  
 University of Georgia, College of Veterinary Medicine  
[famacha@vet.uga.edu](mailto:famacha@vet.uga.edu)  
 (706) 542- 0742

### INTERNATIONAL

Prof Gareth Bath  
 South Africa  
[gareth.bath@up.ac.za](mailto:gareth.bath@up.ac.za)

## COPYRIGHT

The entire concept, illustrations and text of this system is subject to copyright rules and no part may be altered or copied in any way without the written permission of the copyright holders, the Livestock Health and Production Group of the South African Veterinary Association.

## **The Problem:**

RESISTANCE TO  
DEWORMERS IS  
ON THE RISE



*“Bottle jaw” signals a serious problem.*

## **The Solution:**

SMART  
DRENCHING



# Smart Drenching for Sheep and Goats

**Gastrointestinal nematodes (worms)** are a major threat to grazing sheep and goats in the United States. The 2 most important worms are *Haemonchus contortus* (barber pole worm) and *Trichostrongylus colubriformis* (bankrupt worm). Periparturient females, kids and lambs in their first grazing season are especially vulnerable to worms.

## Clinical Signs of Parasitism

- Unthriftiness
- Rough hair coat
- Pasty to watery feces
- Bottle jaw (edema under the jaw)
- Pale membranes in inner eyelid (below)

**Resistance** to all dewormers is increasing in the



worm population, so a newer, smarter approach to worm control is needed. The concept of “smart drenching”\* addresses ways producers can use dewormers (drenches) more selectively and effectively. The primary goal of “smart drenching” is to balance production needs with the need to preserve the efficacy of available dewormers for as long as possible.

\*Thanks to Dr. Des Hennessy, McMaster Laboratory, CSIRO Animal Production, Blacktown Australia, for use of the term, “smart drenching”

## Components of Smart Drenching

1. Find out which dewormers work by performing a fecal egg count reduction test or a DrenchRite larval developmental assay.
2. Weigh each animal prior to deworming them. Sheep are drenched on a body weight basis similar to cattle. Double the cattle/sheep dose when deworming goats for all dewormers (except levamisole). Use levamisole at 1.5 times the cattle/sheep dose in goats.
3. Deliver the dewormer over the tongue in the back of the throat with a drench tip or drench gun.
4. Withhold feed 12-24 hours prior to drenching with benzimidazoles (white dewormers such as fenbendazole and albendazole), ivermectin, doramectrin, and moxidectin.
5. Benzimidazole efficacy is greatly enhanced by repeating the drench 12 hours after the first dose.
6. Simultaneously use 2 classes of dewormers if resistance is suspected.
7. Drench only the animals that need treatment! This step reduces dewormer use. Most importantly, untreated animals harbor worms that have been subjected to less selection pressure for drug resistance. These worms will stay more vulnerable to dewormers.



**The FAMACHA© System** was developed in South Africa to identify severely parasitized sheep and goats. A laminated color chart that shows 5 consecutive grades of conjunctival pallor ranging from 1 (red color; not anemic) to 5 (very pale) is used to score the animals. Only the animals in the palest categories are drenched. This approach decreases the use of dewormers, and allows the producer to identify animals that need frequent deworming to survive.

### **Stopping the Parasite Life Cycle through Pasture Management**

1. Remove small ruminants from pastures for 3-6 months to allow worm larvae on pasture to die off.
2. Alternate or co-graze pastures with horses or adult cattle.
3. Maintain stocking rates of no more than 6-8 small ruminants per acre.



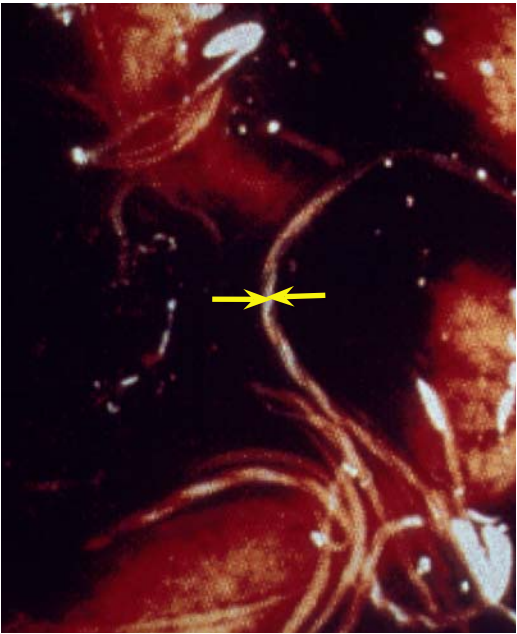

*Haemonchus contortus* in a sheep's abomasum.



Successful management of sheep and goat parasites will involve a combination of management practices that decrease transmission, and intelligent use of dewormers. This brochure outlines several key features of how to control worms in small ruminants.

This Brochure was prepared through the Southern Region USDA Program on Sustainable Agriculture Research and Education (SARE) Program entitled “Novel Methods for Sustainable Control of Gastrointestinal Nematodes in Small Ruminants”

Collaborating Institutions  
Fort Valley State University  
College of Agriculture, Home Economics, and Allied Programs  
Fort Valley, GA

University of Georgia  
College of Veterinary Medicine  
Athens, GA

Louisiana State University  
School of Veterinary Medicine  
Baton Rouge, LA

USDA-ARS, STARS  
Brookville, FL

USDA-ARS  
Booneville, AR

Danish Center for Experimental Parasitology  
The Royal Veterinary and Agricultural University  
Frederiksberg, Denmark

University of Puerto Rico  
Mayaguez, PR

Onderstepoort Veterinary Institute,  
Private Bag X06  
Onderstepoort, South Africa

Visit our web site for more information at  
[www.scsr.org](http://www.scsr.org)



# ANIMAL SCIENCE FACTS

PUBLICATION NUMBER

ANS 00-601MG

## Extension Animal Husbandry

Department of Animal Science

### CONTROLLING SORE MOUTH IN MEAT GOATS

Jean-Marie Luginbuhl  
*Extension Meat Goat Specialist*

Kevin L. Anderson  
*Professor of Veterinary Medicine*

#### Introduction

**Contagious ecthyma**, commonly called **sore mouth**, is a contagious, viral disease of goats and sheep known by several alternative names, including **orf**, **scabby mouth** and **contagious pustular dermatitis**. Sore mouth is common in goats worldwide and can produce painful, thick scabby sores on the lips and gums. Goats infected with sore mouth usually heal completely without scars after one to four weeks. However, in severe cases secondary infections may extend that period. Feed intake may be depressed resulting in weight loss.

Sore mouth is not limited to the mouth. A kid with sore mouth lesions can pass the infection to the teats of a doe during suckling. Lesions appearing on udders are painful and the doe may not allow the kids to nurse and may develop mastitis. The disease may also be passed from infected animals to others. In addition, scabs which have contaminated the environment may be another source of infection. Milking equipment and bedding contaminated by infected does are other possible sources of infection. The lesions are crusty, and may

be secondarily infected with bacteria such as staphylococci and others. Antibiotics are indicated if secondary infections are severe. Although the lips and gums are most commonly affected, lesions have been reported on the face, ears, coronary bands, scrotum, teats, vulva, neck, chest and flank.

The sore mouth virus is very hardy and persists for extended periods away from the host in the dried scabs from an infected animal. Recovery from the disease gives an immunity for at least one year. Transfer of immunity from the doe to the kid through colostrum has not been conclusively proven. Very young kids that are severely affected may die.

#### Diagnosis

Diagnosis is usually based upon clinical appearance. Laboratory tests may be used for confirmation.

#### Treatment

In mild cases, treatment may not be necessary. Softening ointments may help in more severe cases. It is important to make sure that affected animals are eating and drinking. Soft, palatable feeds may help to keep intake up. Antibiotics may be required if secondary infections are severe. Dairy goats with sores on the udder should be milked last and an antiseptic udder salve applied to control bacterial proliferation until healing occurs.

#### Prevention

Commercial vaccines labeled for both

*Reviewed by: Matthew H. Poore, Department of Animal Science and J. Paul Mueller, Department of Crop Science, North Carolina State University*

Distributed in furtherance of the Acts of Congress of May 8 and June 30, 1914. Employment and program opportunities are offered to all people regardless of race, color, national origin, sex, age, or handicap. North Carolina State University, North Carolina A&T State University, U.S. Department of Agriculture, and local governments cooperating.



**North Carolina  
Cooperative Extension Service**

NORTH CAROLINA STATE UNIVERSITY  
COLLEGE OF AGRICULTURE & LIFE SCIENCES

goats and sheep are available and have been of value in some instances. These products should always be used according to product label direction and after consultation with a veterinarian or animal health expert. The vaccines are unattenuated live virus preparations (basically ground-up scabs) or tissue culture strains. Therefore, vaccinating a clean herd will introduce the disease to the herd, and should be done with full consideration of this fact. Scabs appearing at the vaccination site in 1 to 3 days indicate that the vaccine is "taking". For goats that are shown regularly, vaccination prevents the occurrence of an outbreak during the show season. However, it is important to vaccinate animals at least six weeks before the show season, so that vaccine scabs will have disappeared before the first show. Following vaccination, at least two to three weeks are necessary for adequate immunity to take place. Animals are vaccinated in a hairless, protected area. Sites for vaccination include the inside of the ear, the underside of the tail, and others.

It may not be a concern to vaccinate pregnant animals because the vaccine reportedly does not induce abortion. However, the stress of herding pregnant animals into a handling facility and vaccinating them could potentially induce abortion in some animals.

Vaccinated does may give some colostral immunity to kids. However, colostral immunity is short lived, and vaccination should focus on vaccinating each new kid

crop. In some programs, annual revaccination of late pregnant does is performed along with vaccination of the new kid crop.

Disinfection of the pens after all lesions have cleared is recommended in case the owner of an infected herd chooses not to follow a routine vaccination program.

### **Human Health Concerns**

The sore mouth virus may infect man. Persons handling affected animals or vaccinating goats or sheep should wear gloves at all times when handling these animals or the vaccine to protect against acquiring infection.

### **Summary**

Sore mouth is a contagious, viral disease that produces thick, scabby sores on the lips and gums and may also be observed on udders or other areas. Sore mouth usually runs its course in one to four weeks except in cases of secondary infections. Treatment is of little value. Softening ointments and soft and palatable feed may help to keep feed intake up. Commercial vaccines labeled for goats and sheep are available. However, because the vaccine is a live virus product, vaccinating a clean herd will introduce the disease to the herd. Persons vaccinating goats or handling goats with sore mouth should wear gloves at all times.

# Coccidiosis in Lambs

J. S. Rook, D.V.M.  
MSU Extension & MSU Ag Experiment Station  
Department of Large Animal Clinical Sciences  
College of Veterinary Medicine  
Michigan State University

**Key words:** scours, lambs, coccidiosis, internal parasites, medication, treatment & prevention

Midwestern sheep producers are commonly confronted with scouring lambs that do not appear to respond to treatment with traditional de-worming medications. While scouring lambs may be heavily parasitized with stomach or other intestinal worms, a protozoal parasite known as coccidia is often the real culprit. Coccidiosis, like other internal parasite problems, is directly linked to contamination of the lambing area or pastures with coccidia “eggs” (oocysts) passed in the manure of infected ewes and lambs. While a certain base level of coccidia contamination of the environment goes along with raising sheep (often resulting in no obvious clinical signs), clinical disease develops when an unreasonable number of oocysts become established in the environment and ingested by non-immune lambs. Signs of clinical disease (scours) generally occur about 18 to 20 days after ingestion of sufficient amounts of coccidia oocysts from the contaminated environment. Understanding parasite life cycle and the relationship of that life cycle to your specific production scheme is of enormous importance in prevention, diagnosis and control of coccidiosis outbreaks. It is also important in understanding why some medications designed for prevention are not particularly effective.

In winter lambing production systems, coccidiosis outbreaks are common in 3 to 6-week-old lambs that are infected with coccidia oocysts shortly after birth (first few days of life). In our area, outbreaks of clinical disease in winter lambing flocks commonly occur when lambs are about 20 to 30 days old. Coccidiosis is also more common during the second half of winter lambing, when the wet and relatively warmer transitional weather of late February and March contributes to coccidiosis survival and spread in the environment. Additionally, increased crowding of lambs and ewes during the second half of lambing season exponentially increases environmental contamination of the lambing facilities. In contrast, flocks utilizing spring lambing production systems usually experience coccidiosis outbreaks while lambs are on pasture. Newborn lambs spend little or no time in highly contaminated lambing barn environments, therefore, outbreaks on pasture can occur at various ages. Environmental contamination and resulting clinical disease is generally influenced by local weather conditions and the grazing management practices of the flock.

Hopefully, you can see that understanding coccidia host/parasite relationships is essential. Successful prevention, control, and treatment of coccidiosis requires a basic understanding of the parasite and its life cycle.

## *Key Elements of the Disease*

1. **Clinical coccidiosis predominantly affects young, growing lambs.** Unexposed lambs confronted with large numbers of the parasite develop clinical disease but they also develop immunity. Clinical disease is followed by permanent resistance. Immunity (resistance) occurs 3 to 4 weeks after infection.
2. **The ewe, although immune to clinical coccidiosis, harbors the parasite in its intestinal tract.**



Therefore, initial transmission of coccidiosis to the lamb occurs via the ewe. Lambs, once infected, then contaminate each other. *Prevention of clinical coccidiosis in lambs necessitates targeting of the ewe flock. Prevention in purchased feeder lambs requires targeting infected lambs.*

3. **Transmission of coccidiosis occurs via oral ingestion of the parasite.** Adult ewes, which innocuously harbor the parasite, pass the infective stage of the parasite (oocysts) in their manure. Fecal contamination of hay, grain, bedding, pasture, teats, water troughs, creep feeders, etc., are all sources of infection. Signs of clinical disease develop about 17 days after infection with pathogenic levels of coccidia oocysts. This 17 day “incubation period” is often helpful in determining when exposure occurred and how to prevent future exposure to oocysts in your specific production system. It also helps to illustrate just how early oocysts infect lambs in winter lambing system and why medicated creep feeds often fail to prevent clinical disease (lambs are not eating medicated creep feed when contaminated very early in life). Furthermore, the importance of preventing the asymptomatic ewe from contaminating the lambing barn with oocysts should be obvious.
4. **Transmission of coccidiosis to lambs favors warm, wet environmental conditions.** Coccidiosis is seasonally related to when a flock lambs. Clinical disease typically erupts during transition from winter to spring. Outbreaks are often related to seasonal variations in rainfall.
5. **The coccidia organism does not respond to any of the standard deworming products commonly used in the industry.** This is the reason why producers often continue to observe scouring after deworming -- coccidia were really the cause.
6. **Medications used to treat clinical coccidiosis differ from medications used for prevention.** Producers need to identify if treatment and/or prevention is desired and use the appropriate medications.
7. **Environmental buildup (concentration) of the organism occurs in the lambing barn and feedlot.** Lambing barn outbreaks of coccidiosis often correspond to the second half of the lambing season, when organism concentrations, animal crowding and wet conditions are conducive to oocyst transmission. Pasture outbreaks of coccidiosis often correspond to spring or fall rains.
8. **Fecal flotation may or may not be a helpful diagnostic tool.** Veterinarians utilize microscopic identification of coccidia oocysts in the manure of a scouring lamb to link scouring to coccidiosis. However, failure to demonstrate coccidia oocysts in a fecal sample from a 4-week-old lamb may not necessarily indicate that coccidia are absent. **Example:** Coccidiosis is common in 3 to 4-week-old lambs, yet these lambs seldom shed coccidia organisms in their manure when the outbreak begins. Scouring usually starts about 17 days after infection, however, coccidia oocysts may not be evident in the fecal sample for another 5 days (about 22 days after initial infection). In other words, the coccidia organism is mature enough to cause scouring, but not mature enough to shed oocysts in the manure. It is a little like the analogy of finding an egg in the hen house. Finding the egg signals the presence of a hen. However, lack of an egg doesn't indicate her absence.
9. **Individual animal treatment for clinical coccidiosis is difficult, but often necessary, if affected lambs are extremely ill or have not been weaned.** Logistical problems result from: 1) the large number of lambs infected; 2) orally administered medications; and 3) daily treatment regimes for 3 to 7 days. Prevention is a much better alternative - especially where large numbers of lambs are involved.
10. **Lamb feed consumption (especially unweaned lambs) is unpredictable.** Preventive/therapeutic

medication of creep and grower rations often must exceed federally approved levels if therapeutic/preventive amounts of medication are to be consumed. Early outbreaks of coccidiosis in lambs are difficult to prevent with medicated creep feed alone. The problem is not so much ineffectiveness of the medication, but instead, lack of adequate intake in very young lambs and contamination very early in life.

11. **Stress often induces outbreaks of coccidiosis.** Coccidiosis often follows weaning or shipping stresses.
12. **Pneumonia outbreaks often parallel or follow clinical coccidiosis infections.** The conditions conducive to lambing barn pneumonia (poor ventilation, humidity, over crowding, wet bedding etc.) are also conducive to oocyst survival.
13. **Lots of dry straw** also helps to “bed away” from infective oocysts and the moisture they need to survive. A thick, well bedded manure pack allows more moisture to leave the surface layer of bedding than does a thin pack on freshly cleaned cement. Coccidiosis is one disease where excessive cleaning of cement floored barns may actually be conducive to moisture accumulation and oocyst survival.

Hopefully, the preceding generalizations concerning coccidia infections have left you with the feeling that there are no any black or white answers to the coccidiosis question. That was the intent! Producers need to recognize that a combination of factors precipitate coccidiosis and a similar combination of factors can aid in prevention. Needle and syringe delivery systems just don't work! Coccidiosis control necessitates understanding how your management decisions affect the disease.

### *Clinical Coccidiosis*

*Clinical coccidiosis* affects both nursing and growing lambs. Clinical disease involves scouring (as evidenced by soiling of the rear quarters), with occasional (rare) blood observed in the feces. Unless other diseases are present, lambs generally exhibit no elevation in temperature. Typically, lambs appear empty, slightly depressed and rectal straining is evident. Although uncommon, severe infections can lead to death. In most outbreaks of coccidiosis, the real losses are reduced feed efficiency and poor performance often go unnoticed. Lambs just take 2 to 4 weeks longer to get to market, which means more money spent on feed.

Occasionally, coccidiosis can also lead to chronic thickening of the intestinal wall, resulting in malabsorption and stunted growth. Rectal prolapses are also associated with rectal straining from the diarrhea. Normally, within 2 to 3 weeks following infection, immunity develops and scouring subsides.

**Treatment for clinical cases of coccidiosis** is time consuming, costly, and dependent upon lamb age, facilities, feeding program, and available medications. Unweaned lambs and younger animals that are not on consistent levels of feed or water consumption must be individually treated. Older lambs may be group treated in the feed or drinking water. In most cases, group therapy is best accomplished by water medications. Sick animals will generally drink, even if they are "off feed." Treatment involves medication with either oral sulfonamide preparations or oral preparations of amprolium. Stressed lambs with coccidiosis often experience concurrent problems with pneumonia. Oral sulfonamide medications, which are effective against both coccidia and common pneumonia-causing organisms (amprolium only works on coccidia), are the most common *treatment* medications recommended by veterinarians. Some coccidiosis outbreaks tend to respond better to one or the other type of medication. Personal preference would be to start treatment with a sulfonamide preparation.

**Sulfonamide medications.** Many sulfonamide medications can be used to treat coccidiosis. Most preparations are sold as packets of powders or as gallons of liquid that can be added to drinking water. **Example:** A 12.5% solution of sulfadimethoxine (Albon) is commonly prescribed by veterinarians. *Group treatment* dosages might include add 1 pint of this solution to each 25 gallons of drinking water for 3-5 days. *Individual treatment* might include a daily drench of 4 cc of the 12.5% sulfadimethoxine solution per each 25 lbs of body weight for 3-5 days. Producers should consult their veterinarians for products and doses appropriate for their given management schemes. Also remember that many sulfonamide medications are bitter tasting. Commercial products often include flavoring ) or packets of j can be added to enhance consumption.

**Amprolium Medications.** Amprolium (Corid) is also labeled for use as both a treatment and preventative for coccidiosis. Amprolium comes as both a feed additive and as a liquid for drinking water medication.

- Sample **treatment dose:** Treatment is continued for 5 days using one pint of a 9.6% oral solution of amprolium added to 100 gals of drinking water.
- Sample **prevention dose:** Prevention is continued for 21 days using one-half pint (8 oz) of a 9.6% oral solution of amprolium added to 100 gallons of drinking water.

Individual lambs can also be drenched with amprolium for both treatment and prevention of coccidiosis.

- **Treatment** involves making a stock solution by mixing 3 oz of 9.6% amprolium solution in 1 pint of water. This stock solution is then drenched daily at the rate of 1 oz of stock solution per 100 lbs of body weight for 5 days.
- **Prevention** doses involve making a stock solution by mixing one and one-half ounces of the 9.6% amprolium solution with 1 pint of water. This stock solution is then drenched daily at the rate of 1 oz of stock solution per 100 lbs of body weight for 21 days.

**CAUTION!** It is extremely rare, but polioencephalomalacia (caused by a thiamine deficiency to the brain) can be induced as a side effect of amprolium treatment. The mechanism of action of amprolium may provoke a thiamine-like deficiency, causing the typical neurological symptoms observed with polioencephalomalacia.

### ***Feed Additives for Prevention of Coccidiosis***

Newer feed additives for the prevention of coccidiosis in lambs are currently in use by the sheep industry. These compounds include two FDA-approved products known as, lasalocid (trade name Bovatec), and decoquinate (trade name Deccox) and one non-approved product called, **monensin (trade name Rumensin)**. Monensin requires a veterinarian-client-patient relationship for use.

### **Killing Coccidia vs Reducing Coccidial Shedding ) IMPORTANT ISSUE!**

*Preventive medications* such as monensin, lasalocid, and decoquinate, are collectively referred to as coccidiostats (meaning that they slow down the shedding of coccidia into the environment). They should be used for prevention, not treatment of coccidiosis. The theory behind employing lasalocid, monensin, or decoquinate in a feeding program is to reduce the shedding of infective levels of coccidia oocysts into the environment of the lamb. Remember that ewes and previously infected lambs that have developed immunity, although they may show no signs of clinical disease, const

shed coccidia into the lambing barn, dry-lot, and pasture environment throughout their entire life. They are what we refer to as asymptomatic carriers or coccidia. Reducing coccidia oocyst contamination in the environment prevents clinical disease, yet allows lambs to have enough exposure to coccidia to develop immunity. Like most exposures to any disease, it is somewhat of a numbers game, high populations of oocysts in the environment lead to disease. Lambs can usually handle lower concentrations of oocyst contamination.

Producers and their veterinarians also need to understand that feed additives such as monensin, lasalocid, and decoquinate, are only effective in preventing disease if they are added to the feed before lambs become exposed. Some of these medications also have a lag time between when you start sheep on the medicated feed and when the oocysts stop being passed in the manure. This lag time varies between products, but is usually about 21 days. Therefore, pregnant ewes (that are responsible for initially contaminating the lambing barn environment) need to be on medicated feed at least 21 days prior to entering the lambing barn and drylot area. Most producers forget this very important point. Furthermore, using lasalocid, monensin, or decoquinate as the only *treatment medication* for clinical outbreaks of coccidiosis has created problems for many a sheep producer! These feed additives are for prevention, not treatment.

On the contrary, **treatment medications such as sulfonamide compounds and amprolium are coccidiacidal** (meaning that they actually kill the coccidia organisms in the intestine of the treated animal). While a 3 to 5 day treatment with appropriate doses of a sulfonamide or amprolium is normally effective against clinical disease, it does not prevent reinfection after treatment ceases. In the past, prevention with these treatment medications was attained by repetitive administrations of the medications every 2 to 3 weeks. Cyclic administration of treatment drugs prevented coccidia contamination of the environment by not allowing newly ingested coccidia time to mature and pass infective eggs in the manure. (Again the hen house analogy - chicks mature to poults who then mature to laying hens. If the chicks were "killed-off" every 2 to 3 weeks, they could never mature to lay eggs.) This maturation process takes about 21 days, thus the rationale for the cyclic 2 to 3 week treatments. Costs, logistics of administration (especially to pastured animals), residue worries, and the development of monensin, lasalocid, and decoquinate, have limited the use of cyclic treatments to specialized situations.

### ***Practical Prevention (General)***

Doses and applications of lasalocid, monensin, or decoquinate will depend upon both your feeding and management programs and veterinarian-client relationships. Lambing operations that consistently experience coccidiosis outbreaks should utilize the addition of preventive medication to the ewe grain or salt mix *prior to* and throughout lambing. This practice reduces coccidia contamination of the lambing premises and thereby controls the spread of coccidia to the lamb crop. The aforementioned practice, coupled with the addition of preventive medication in the lamb ration (creeper feed to finishing), suppresses coccidiosis shedding to levels that prevent clinical disease.

Because most Midwestern producers feed grain to ewes during late pregnancy, the practice of adding medication to the late gestation diet should not be too cumbersome. ***It is important to remember that any preventive medication needs to be in the ewe diet for at least 21 days prior to the ewe being moved into the lambing facility. These preventive medications need to be used for this length of time to be effective!*** This is an important area of breakdown in a control program. Producers unfairly blame the feed additive for being ineffective, when producer misapplication is really the culprit.

**Sanitation** ) If the lambing barn has recently housed feeder lambs, or continually houses sheep, the premises may already be contaminated. Lambing areas with this history should be cleaned and left to stand idle for several weeks

prior to introducing the medicated ewes. If weather or animal use prohibits cleaning the area, producers should use a heavy bedding of straw to isolate the incoming ewes from the preexisting coccidia. This layer of straw will also create a dry area less conducive to the spread of coccidia. ***Breaking the coccidia cycle by hauling manure and allowing an area to be void of animal units is an important part of any disease control program. Give some thought to your management scheme to allow this to happen!***

### ***Dosage Rates for Lasalocid, Monensin and Decoquinat***

**Lasalocid** (Bovatec) is included in many feeder lamb 35% protein supplement pellets, complete feeds, or it can be purchased as an individual additive. ***The FDA approved rate for lasalocid use in sheep is 30 grams per ton of feed.*** While this approved level allows for adequate lasalocid consumption for finishing rations and for the ewe flock, it may not provide adequate doses of lasalocid in the creep or grower ration. Young lambs consume only very small amounts of feed; therefore, they may not ingest an appropriate amount of the medication. For this reason, practitioners with an appropriate client-patient-veterinarian relationship may recommend increasing lasalocid rates to as high as 90 grams/ton in the creep ration, 60 grams/ton in the grower ration (40-70 lb lambs), and the approved 30 grams/ton in the finisher diet (lambs over 70 lbs).

**Monensin** (Rumensin), while not approved by the FDA for use in sheep, is effective for prevention of coccidiosis. Numerous monensin-containing feed additives are available for cattle and should only be used for sheep if a client-patient-veterinarian relationship exists. Monensin dosage is at the 15 gram/ton level. ***CAUTION!!! ) Monensin is extremely toxic to sheep if dosages are incorrect. Improper mixing, errant calculations, and inappropriate use of highly concentrated cattle products can lead to toxicity and death! There is no antidote! Cattle salt blocks containing concentrated levels of monensin are extremely dangerous to sheep. Products formulated for cattle may also contain high levels of copper or other toxic elements. Scours is a common sign of both coccidiosis and early monensin toxicity. Since they are already treating scouring lambs resulting from coccidiosis, producers often fail to associate the continued scouring with possible toxicity.***

**Decoquinat** (Deccox, a 6% decoquinat preparation) can also be used to help prevent coccidiosis in sheep. It has been recently approved for use in sheep. Two pounds of the 6% decoquinat preparation (Deccox) can be added to 50 lbs of a loose trace-mineral salt. This preparation can then be fed free-choice to the ewe flock or grazing sheep. This is a convenient method for coccidiosis control in grazing management systems that do not grain feed lambs. ***Caution:*** A 0.6% decoquinat preparation is also available and should not be confused with the 6% Deccox product. This has been a common mistake in our area.

### ***Final Caution***

Producers that house horses in the same area as sheep should use EXTREME CAUTION with storage, feeding, and purchasing of products designed for the prevention of coccidiosis in sheep or cattle. Monensin (Rumensin) is extremely toxic to horses! Ingestion of very small amounts of the product is usually fatal. Lasalocid (Bovatec) and decoquinat (Deccox) are much less of a problem but should still not be fed to horses (or any equine species - guard donkeys etc.). Avoid any possibilities of consumption by equine species.

## Is it Necessary to Vaccinate Goats Against Overeating Disease and Tetanus?

**Jean-Marie Luginbuhl**  
Extension Meat Goat Specialist

Although some producers have so far not experienced problems by not immunizing their goats, it is recommended to vaccinate the entire herd against overeating disease (enterotoxemia) and tetanus. Both diseases are caused by *clostridial bacteria*. Some formulations contain the overeating disease and tetanus vaccines in the same bottle. In that case, goats can be immunized against both diseases in one single injection. These 2-in-1 vaccines simplify herd preventive health programs and decrease costs.

### ***What is overeating disease?***

Overeating disease is an acute, often fatal, disease affecting goats of all ages, but that tends to be more lethal in young kids, and often in those which are doing best. It is caused by the bacteria *Clostridium perfringens* types C and D. The bacteria are commonly found in the soil, and are present in the intestines of most normal goats.

The lethal action of these organisms is that they release toxins into the blood which give rise to shock and nervous symptoms (type D), or cause inflammation of the lining of the gut and diarrhea with blood (type C).

Avoiding the conditions which allow the organisms to proliferate in the intestines and release their toxins are important. The main danger period occurs during the first few days after any change of pasture or diet, such as a change from a high quality pasture to a poor pasture or to a higher level of concentrates. Changes in feeding programs must therefore be gradual, and up to a week should be taken to change from one type of feed to another. It is also important to avoid overeating by kids, for example after they have become excessively hungry.

### ***What are the symptoms of overeating disease?***

Twitching, star gazing, teeth grinding, fever, swollen stomach, diarrhea with blood, convulsions, and death within a few hours. Affected goats are often found dead or in a terminally shocked condition with convulsions.

### **What is tetanus?**

Tetanus is caused by a neurotoxin produced by the bacterium *Clostridium tetani*. This organism is very common in soil and in the manure of all animals. Bacterial spores enter the body through wounds following castration, ear tagging, disbudding, kidding, etc., resulting in signs of the disease 4 to 21 days later. The toxin affects the central nervous system.

### **What are the symptoms of tetanus?**

Stiff muscles, spasms, flared nostrils, erect ears and elevated tail. In addition, the affected animals have a difficult time opening their mouths, so the term lockjaw given to the disease. Eventually, the affected animals lie down and die.

### **What vaccine should be used?**

1. ***Clostridium perfringens* Types C and D +Tetanus Toxoid** in one vaccine. This vaccine is labeled for goats.
2. **Multivalent clostridial vaccine ( 8-way vaccine)**  
One example of a multiway clostridial vaccine, labeled for sheep, is **Covexin8**. Covexin8 is more reactive and **generally causes a higher incidence of adverse reaction at the injection site**.  
Covexin8 may preferably be used in herds which have had problems with **blackleg** and **malignant edema (gas gangrene)**. Although blackleg and malignant edema are common and costly infections in sheep and cattle, they are very uncommon in goats.

### **What dosage should be used and when should goats be vaccinated?**

**Always read the instructions provided with the vaccine.**

1. *Clostridium perfringens* Types C and D + Tetanus

#### **Dosage**

- 2 mL (2 cc) per animal, regardless of age and weight

#### **When**

**Bucks**. Once a year

**Breeding females**. 4 to 6 weeks before kidding. By vaccinating does in late pregnancy, some immunity will be passed on to the kids through the colostrum.

**Kids**. If breeding females have been vaccinated before kidding, vaccinate kids at 8 weeks of age, then give a booster at 12 weeks of age.

If breeding females have not been vaccinated before kidding and you experience problems, vaccinate kids at 2 weeks of age, then give them a booster at 6 weeks of age.

2. Multivalent clostridial vaccine (Covexin8)

#### **Dosage**

- 5 mL (5 cc) per animal, regardless of age and weight. Kids get 5 mL (5 cc) initially, then a 2 mL (2 cc) booster 6 weeks later.

#### **When**

**Bucks**. Once a year

**Breeding females**. 4 to 6 weeks before kidding. By vaccinating does in late pregnancy, some immunity will be passed on to the kids through the colostrum.

**Kids.** If breeding females have been vaccinated before kidding, vaccinate kids at week 8 to 12 of age, then give them a booster at week 16 to 18 of age.

If breeding females have not been vaccinated before kidding and you experience problems, vaccinate kids at 4 weeks of age, then give them a booster at 10 weeks of age.

### ***How should I give the injections and where?***

Both *Clostridium perfringens* Types C D /Tetanus and multivalent clostridial vaccines are given in sub-cutaneous or intramuscular injections. Sub-cutaneous injections are favored because of the greater tissue damage at the injection site from intramuscular injections.

For sub-cutaneous injections, pinch loose skin between thumb and index finger high on the neck (as close to the head as possible) and insert the needle. Make sure that the needle is under the skin and does not stick out on the other of the pinched skin.

### ***Is there a slaughter withdrawal time?***

Yes, there is a 21 day waiting period between vaccination and slaughter for both vaccines.

### ***The bottom line***

A sickness in one goat or in the whole herd can cost much more when sick animals have to be treated compared to the cost of prevention. Some health problems cannot even be treated. Thus, prevention is the only sensible approach to goat herd disease management.



## Scrapie

Scrapie is a fatal, degenerative disease affecting the central nervous system of sheep and goats. It is among a number of diseases classified as transmissible spongiform encephalopathies (TSE). Infected flocks that contain a high percentage of susceptible animals can experience significant production losses. Over a period of several years the number of infected animals increases, and the age at onset of clinical signs decreases making these flocks economically unviable. Female animals sold from infected flocks spread scrapie to other flocks. The presence of scrapie in the United States also prevents the export of breeding stock, semen, and embryos to many other countries. TSEs are the subject of increased attention and concern because of the discovery of bovine spongiform encephalopathy (BSE) in cattle, the link between BSE and variant Creutzfeldt-Jakob disease (vCJD) in people, and feline spongiform encephalopathy (FSE) in cats in Europe. This increased concern has led to the following:

- Packers and producers have had difficulty finding options for disposal of sheep offal and dead sheep causing packers and producers to incur significant increases in disposal costs,
- Other countries have expressed concerns and have indicated that they may prohibit or restrict certain ruminant products because the United States has scrapie, and
- Domestic and international markets for U.S. sheep-derived meat and bone meal have been adversely affected.

The combination of all of these factors has led to the decision to develop a strong scrapie eradication program in the United States.

### Epidemiology and Transmission

The agent responsible for scrapie and other TSEs is smaller than the smallest known virus and has not been completely characterized. There are three main theories on the nature of the scrapie agent: (1) the agent is a prion, which is an abnormal form of a normal cellular protein, 2) the agent is a virus with unusual characteristics, and (3) the agent is a virino, a very small piece of DNA that acts like a virus. The scrapie agent is extremely resistant to heat and to normal sterilization processes. It does not evoke any detectable immune response or inflammatory reaction in sheep and goats.

The scrapie agent is thought to be spread most commonly from the ewe to her offspring and to other lambs through contact with the placenta and placental fluids. Signs or effects of the disease usually appear 2 to 5 years after the animal is infected but may not appear until much later. Sheep may live 1 to 6 months or longer after the onset of clinical signs, but death is inevitable. The genetics of the sheep affects their susceptibility to scrapie.

In the laboratory, the scrapie agent has been transmitted to hamsters, mice, rats, voles, gerbils, mink, cattle, and some species of monkeys by inoculation. There is no scientific evidence to indicate that scrapie poses a risk to human health. There is no epidemiologic evidence that scrapie of sheep and goats is transmitted to humans, such as through contact on the farm, at slaughter plants, or butcher shops.

### Clinical Signs

Signs of scrapie vary widely among individual animals and develop very slowly. Due to damage to nerve cells, affected animals usually show behavioral changes, tremor (especially of head and neck), rubbing, and locomotor incoordination that progresses to recumbency and death.

Early signs include subtle changes in behavior or temperament. These changes may be followed by scratching and rubbing against fixed objects, apparently to relieve itching. Other signs are loss of coordination, weakness, weight loss despite retention of appetite, biting of feet and limbs, lip smacking, and gait abnormalities, including high-stepping of the forelegs, hopping like a rabbit, and swaying of the back end.

An infected animal may appear normal if left undisturbed at rest. However, when stimulated by a sudden noise, excessive movement, or the stress of handling, the animal may tremble or fall down in a convulsive-like state.

Several other problems can cause clinical signs similar to scrapie in sheep, including the diseases ovine progressive pneumonia, listeriosis, and rabies; the presence of external parasites (lice and mites); pregnancy toxemia; and toxins.

On the farm, veterinarians diagnose scrapie based on the appearance of its signs combined with knowledge of the animal's history. Scrapie can be diagnosed in the live animal by biopsy of the lymphoid tissues on the inside of the third eyelid. This test is used by the U.S. Department of Agriculture's (USDA) Animal and Plant Health Inspection Service

(APHIS) to determine whether exposed flocks are infected. Scrapie is most often diagnosed by microscopic examinations of brain tissue at necropsy or by procedures that detect the presence of the abnormal prion protein in brain tissue.

## Research

Scrapie research efforts are currently focused on developing more practical live-animal tests to diagnose infected sheep before they show signs, investigating transmissibility of the agent, identifying the scrapie agent and its different strains, identifying genes that influence scrapie infection and evaluating genetic selection as a tool for scrapie eradication. Substantial evidence has accrued to show that the risk of scrapie transmission by embryo's is negligible provided that the embryos are properly handled between collection and transfer, but additional experimental data are needed to support existing evidence.

## Related Diseases

The TSE family of diseases includes BSE: transmissible mink encephalopathy; FSE; chronic wasting disease of deer and elk; kuru; both classical and variant Creutzfeldt-Jakob disease; Gerstmann-Straussler-Scheinker syndrome; and fatal familial insomnia. TSEs have also been reported in Europe in captive wild ruminants in the bovid family, cats, and monkeys. The occurrence of TSEs in captive wild animals is believed to have resulted from BSE-contaminated feed.

## Eradication Program

USDA has initiated an accelerated scrapie eradication program. The program is based on the following key concepts:

- Identification of preclinical infected sheep through live animal testing and active slaughter surveillance,
- Effective tracing of infected animals to their flock/herd of origin made possible as a result of the identification requirements, and
- Providing effective genetic based flock cleanup strategies that will allow producers to stay in business, preserve breeding stock, and remain economically viable. APHIS provide the following to exposed and infected flocks/herds that participate in cleanup or monitoring plans:
  1. Indemnity for high-risk, suspect, and scrapie positive sheep and goats, which owners agree to destroy,
  2. Scrapie live-animal testing,
  3. Genetic testing, and
  4. Testing of exposed animals that have been sold out of infected and source flocks/herds.

Operating an effective program to deal with this insidious disease requires cooperation among producer organizations, allied industries, and governmental agencies.

## History

First recognized as a disease of sheep in Great Britain and other countries of Western Europe more than 250 years ago, scrapie has been reported throughout the world. Only two countries are recognized by the United States as being free of scrapie: Australia and New Zealand.

The first case of scrapie in the United States was diagnosed in 1947 in a Michigan flock. The flock owner had imported sheep of British origin through Canada for several years. APHIS conducted a slaughter surveillance study from April 1, 2002, to March 31, 2003, which determined the prevalence of scrapie in mature U.S. cull sheep to be 0.2 percent or one positive out of 500 cull sheep.

In the United States, scrapie has primarily been reported in the Suffolk breed. It also has been diagnosed in a Border Leicester, Cheviots, Corriedales, a Cotswold, Dorsets, Finn sheep, Hampshires, Merinos, Montadales, Rambouillets, Shropshires, Southdowns, and a number of crossbreeds. Through October 2003, approximately 2,350 cases in sheep and 12 cases in goats have been reported.

## Additional Information

For more information about scrapie, contact your local APHIS, Veterinary Services, area office or contact:

USDA, APHIS, Veterinary Services  
National Animal Health Programs  
4700 River Road, Unit 43  
Riverdale, MD 20737-1231  
Telephone (301) 734-6954  
Fax (301) 734-7964

Current information on animal diseases and suspected outbreaks is also available on the Internet.

Point your Web browser to <http://www.aphis.usda.gov/vs/naahps/scrapie/> to reach the APHIS scrapie home page.

---

The U.S. Department of Agriculture (USDA) prohibits discrimination in all its programs and activities on the basis of race, color, national origin, sex, religion, age, disability, political beliefs, sexual orientation, or marital or family status. (Not all prohibited bases apply to all programs.) Persons with disabilities who require alternative means for communication of program information (Braille, large print, audiotope, etc.) should contact USDA's TARGET Center at (202) 720-2600 (voice and TDD).

To file a complaint of discrimination, write USDA, Director, Office of Civil Rights, Room 326-W, Whitten Building, 14th and Independence Avenue, SW, Washington, DC 20250-9410 or call (202) 720-5964 (voice and TDD). USDA is an equal opportunity provider and employer.

- HOME
- ABOUT SCRAPIE
- HOW TO COMPLY
- STATE ID REQUIREMENTS
- STATE/FEDERAL CONTACTS
- TAG COMPANIES
- EDUCATIONAL RESOURCES
- LOS MATERIALES EDUCACIONLES
- ADDITIONAL RESOURCES
- SHEEP & GOAT HEALTH REPORT
- NEWS ROOM
- CONTACT US



# ERADICATE SCRAPIE!



**Your Participation is Needed Now, More Than Ever —To Reach the Goal of Substantially Eradicating Scrapie from the U.S. by 2010**

## Individual State Identification Requirements: What Sheep and Goats Need Official USDA-Approved Ear Tags

All states require certain sheep and goats to be officially identified on change of ownership. And, while many states have identical requirements to the USDA interstate requirements, other states have additional requirements regarding intrastate movement and/or interstate movement, and some states exempt certain classes of sheep and/or goats. It is your responsibility as a person who owns or handles sheep or goats to know and adhere to state requirements for your respective state and, if moving out of state, to know and adhere to the federal requirements and those of the states to where animals are being moved.

The information provided below addresses state requirements regarding sheep and goats needing official identification (USDA-approved ear tags are the most commonly used official identification).

Please be aware that certain states also require a Certificate of Veterinary Inspection (official health certificate) and/or an import permit when animals are being moved within or into the state or being trucked through the state—and it is your responsibility to know and adhere to those specific state requirements as well.

To learn more about a specific state's scrapie identification requirements regarding interstate or intrastate movement, contact the appropriate State Veterinarian (SV).



Photo courtesy of Premier 1 Supplies

For questions regarding USDA interstate requirements or to obtain official eartags, contact the USDA VS Area office listed below.

Updated as of **April 2008**

- |    |    |    |    |    |    |    |    |    |    |    |    |    |    |    |
|----|----|----|----|----|----|----|----|----|----|----|----|----|----|----|
| AL | AK | AZ | AR | CA | CO | CT | DE | FL | GA | HI | ID | IL | IN | IA |
| KS | KY | LA | ME | MD | MA | MI | MN | MS | MO | MT | NE | NV | NH | NJ |
| NM | NY | NC | ND | OH | OK | OR | PA | RI | SC | SD | TN | TX | UT | VT |
| VA | WA | WV | WI | WY |    |    |    |    |    |    |    |    |    |    |

### Federal Requirements

**\*Note: Personnel changes occur often; however, phone numbers typically endure through these personnel changes.**

[\[back to top\]](#)

### Alabama

All sheep and goats require an official ear tag prior to moving off the premises of origin. Complete information is available at [www.agi.alabama.gov/infectious\\_disease/scrapie-detail-info](http://www.agi.alabama.gov/infectious_disease/scrapie-detail-info) or by contacting:

[\[back to top\]](#)

### Connecticut

All sheep and goats require an official ear tag prior to moving off the premises of origin. Complete information is available by contacting:

Dr. Mary Lis, SV  
 Ph: 860-713-2505  
 E-mail: [ctdeptag@ct.gov](mailto:ctdeptag@ct.gov)

USDA/APHIS/VS Office  
 Dr. Lech Szkudlarek  
 Ph: 508-363-2290  
 E-mail: [lech.szkudlarek@aphis.usda.gov](mailto:lech.szkudlarek@aphis.usda.gov)

[\[back to top\]](#)

### Delaware

All sheep and goats require an official ear tag prior to moving off the premises of origin. Complete information is available by contacting:

Dr. Sara Busch, SV  
 Ph: 302-698-4451  
 E-mail: [sara.busch@state.de.us](mailto:sara.busch@state.de.us)

USDA/APHIS/VS Office  
 Dr. Kent Holm  
 Ph: 410-349-9708  
 E-mail: [kent.b.holm@aphis.usda.gov](mailto:kent.b.holm@aphis.usda.gov)

[\[back to top\]](#)

### Florida

**FDOACS Stakeholder Letter Regarding Intrastate Movement Requirements for Sheep & Goats.** All sheep and goats must have official individual identification. All goats and sheep entered for exhibition purposes must have an official individual identification. Complete information is available at [www.doacs.state.fl.us/ai/main/rules.shtml](http://www.doacs.state.fl.us/ai/main/rules.shtml) or by contacting:

Dr. Tom Holt, SV  
 Ph: 850-410-0910  
 E-mail: [holt@doacs.state.fl.us](mailto:holt@doacs.state.fl.us)

USDA/APHIS/VS Office  
 Susan Loezel  
 Ph: 352-313-3060  
 E-mail: [susan.m.loezel@aphis.usda.gov](mailto:susan.m.loezel@aphis.usda.gov)

[\[back to top\]](#)

### Georgia

In addition to Federal requirements, Georgia requires official individual identification of all high-risk goats (those in contact with sheep) as well as official ear tags on all sheep going to a livestock market. Complete information is available by contacting:

Dr. Carter Black, SV  
 Ph: 404-656-3671  
 E-mail: [cblack@agr.state.ga.us](mailto:cblack@agr.state.ga.us)

Dr. Stan Crane  
 Designated Scrapie Epidemiologist  
 Ph: 404-656-3667  
 Email: [stan.crane@agr.georgia.gov](mailto:stan.crane@agr.georgia.gov)

[\[back to top\]](#)

### Hawaii

All sheep and goats require official identification except lambs or kids less than 18 months of age in slaughter channels that have not lambed, kidded, aborted or are pregnant. Complete information is available by contacting:

Dr. Jim Foppoli, SV  
 Ph: 808-483-7111  
 E-mail: [james.m.foppoli@hawaii.gov](mailto:james.m.foppoli@hawaii.gov)

USDA/APHIS/VS Office  
 Dr. Thomas J. Brignole  
 Ph: 360-753-9430  
 E-mail: [thomas.j.brignole@aphis.usda.gov](mailto:thomas.j.brignole@aphis.usda.gov)

[\[back to top\]](#)

### Idaho

All sheep and goats except exempt animals must carry an official ear tag. Exemptions: 1) neutered animals under 18 months of age; 2) breeding animals under 18 months of age shipped directly to an approved slaughter establishment or shipped directly to a feedlot for finish feeding for slaughter only; 3) castrated or low-risk commercial goats; and 4) registered sheep and goats accompanied by registration papers or a certificate of veterinary inspection with legible unique registrations tattoos. Goats registered with a National Goat Registry that allows for electronic implant identification, as recorded on a registration certificate, may be identified with an electronic implant. Complete information is available by contacting:

Dr. Greg Ledbetter, SV  
 Ph: 208-332-8540  
 E-mail: [gledbetter@idahoag.us](mailto:gledbetter@idahoag.us)

USDA/APHIS/VS Office  
 Dr. Mary K. Tinker  
 Ph: 208-378-5631  
 E-mail: [mary.k.tinker@aphis.usda.gov](mailto:mary.k.tinker@aphis.usda.gov)

[\[back to top\]](#)

**Illinois**

All sheep and goats moving within Illinois must be officially identified to their herd/flock of birth. If flock or herd of birth is not known, then they must still be officially identified to the flock or origin by that producer or by a livestock dealer and then move directly to slaughter. Complete information is available at [www.agr.state.il.us](http://www.agr.state.il.us) or by contacting:

Dr. Mark Ernst, SV  
 Ph: 217-782-4944  
 E-mail: [mark.ernst@Illinois.gov](mailto:mark.ernst@Illinois.gov)

USDA/APHIS/VS Office  
 Dr. Rick Jones  
 Ph: 217-494-2600  
 E-mail: [rick.l.jones@aphis.usda.gov](mailto:rick.l.jones@aphis.usda.gov)

[\[back to top\]](#)

**Indiana**

Federal requirements apply. [Click here to view Federal Requirements](#). Complete information is available by contacting:

Dr. Bret D. Marsh, SV  
 Ph: 317-227-0300  
 E-mail: [bmarsh@boah.in.gov](mailto:bmarsh@boah.in.gov)

USDA/APHIS/VS Office  
 Dr. Cheryl Miller  
 Ph: 317-402-1527  
 E-mail: [cmiller@boah.in.gov](mailto:cmiller@boah.in.gov)

[\[back to top\]](#)

**Iowa**

The following sheep and goats must be identified with an official ear tag: 1) All sheep more than 18 months of age; 2) All sexually intact sheep of any age sold, leased or moved for the purpose of breeding or exhibition; and 3) All sexually intact goats used for breeding/milking or exhibition and those that reside with sheep. Complete information is available at [www.iowaagriculture.gov/animalIndustry/scrapieProgram.asp](http://www.iowaagriculture.gov/animalIndustry/scrapieProgram.asp) or by contacting:

Dr. David Schmitt, State Veterinarian  
 Ph: 515-281-5305  
 E-mail: [david.schmitt@idals.state.ia.us](mailto:david.schmitt@idals.state.ia.us)

USDA/APHIS/VS Office  
 Dr. Pamela Smith  
 Ph: 515-284-4140  
 E-mail: [pamela.smith@idals.state.ia.us](mailto:pamela.smith@idals.state.ia.us)

Dr. Sharon Fairchild  
 Ph: 515-284-4140  
 E-mail: [sharon.k.fairchild@aphis.usda.gov](mailto:sharon.k.fairchild@aphis.usda.gov)

[\[back to top\]](#)

**Kansas**

Kansas follows Federal requirements for intrastate movement for sheep and goats with one exception: Goats must be identified even if they have not commingled with sheep. Goats moving directly to slaughter in Kansas that are maintained and slaughtered as a group so that the premises of origin can be identified do not require individual identification. All other goats, except wethers under 18 months of age, are required to be identified by a registered tattoo or by an official scrapie tag. [Click here to view Federal Requirements](#). Complete information is available by contacting:

George Teagarden, SV  
 Ph: 785-296-2326  
 E-mail: [gteagarden@kahd.ks.gov](mailto:gteagarden@kahd.ks.gov)

USDA/APHIS/VS Office  
 Dr. Donald Evans  
 Ph: 785-235-2365  
 E-mail: [donald.e.evans@aphis.usda.gov](mailto:donald.e.evans@aphis.usda.gov)

[\[back to top\]](#)

**Kentucky**

All sheep and goats of any age or sex must carry an official ear tag on change of ownership and prior to moving off the premises of origin. Breed registration tattoos are acceptable for identification purposes if producers have registration papers and if the market or sale chooses to read and check the tattoos. Complete entry requirements and requirements for interstate and intrastate movement may be accessed at [www.kyagr.com/statevet/sheepandgoat/index.htm](http://www.kyagr.com/statevet/sheepandgoat/index.htm) or by contacting:

Dr. Robert Stout, SV  
 Ph: 502-564-3956

USDA/APHIS/VS Office  
 Dr. Judy Morley

E-mail: [robert.stout@ky.gov](mailto:robert.stout@ky.gov)

Ph: 502-848-2044

E-mail: [judy.morley@aphis.usda.gov](mailto:judy.morley@aphis.usda.gov)

[\[back to top\]](#)

### Louisiana

All sheep and goats require official identification except low-risk sheep and goats as defined by USDA. Complete information is available by contacting:

Dr. Henry Moreau., acting SV

Ph: 504-925-3980

E-mail: [hmoreau@ldaf.state.la.us](mailto:hmoreau@ldaf.state.la.us)

USDA/APHIS/VS Office

Dr. Scott DeJean

Ph: 225-389-0436

E-mail: [scott.k.dejean@aphis.usda.gov](mailto:scott.k.dejean@aphis.usda.gov)

[\[back to top\]](#)

### Maine

Maine is a scrapie-consistent state and follows Federal requirements. All sexually intact animals must be officially identified on change of ownership for movement within the state, except for those animals less than 18 months of age moving direct to slaughter or those animals less than 18 months of age moving in slaughter channels. [Click here to view Federal Requirements](#). Complete information is available at [www.maine.gov/sos/cec/rules/01/001/001c202.doc](http://www.maine.gov/sos/cec/rules/01/001/001c202.doc) or by contacting:

Dr. Don Hoenig, SV

Ph: 207-287-3701

E-mail: [donald.e.hoenig@maine.gov](mailto:donald.e.hoenig@maine.gov)

USDA/APHIS/VS Office

Dr. Lech Szkudlarek

Ph: 508-865-1421, 1422

E-mail: [lech.szkudlarek@aphis.usda.gov](mailto:lech.szkudlarek@aphis.usda.gov)

[\[back to top\]](#)

### Maryland

Federal requirements apply. [Click here to view Federal Requirements](#). Complete information is available by contacting:

Dr. Guy Hohenhaus, SV

Ph: 410-841-5810

E-mail: [hohenhgs@mda.state.md.us](mailto:hohenhgs@mda.state.md.us)

USDA/APHIS/VS Office

Dr. Kent Holm

Ph: 410-349-9708

E-mail: [kent.b.holm@aphis.usda.gov](mailto:kent.b.holm@aphis.usda.gov)

[\[back to top\]](#)

### Massachusetts

All sheep and goats must have an official ear tag at the change of ownership or at age of 18 months whichever occurs first. Complete information is available by contacting:

Dr. Lorraine O'Connor, SV

Ph: 617-626-1790

E-mail: [lorraine.o'connor@state.ma.us](mailto:lorraine.o'connor@state.ma.us)

USDA/APHIS/VS Office

Dr. Lech Szkudlarek

Ph: 508-865-1421, 1422

E-mail: [lech.szkudlarek@aphis.usda.gov](mailto:lech.szkudlarek@aphis.usda.gov)

[\[back to top\]](#)

### Michigan

All sheep and goats, regardless of age or reproductive capability, must have an official ear tag prior to moving off the premises of origin. Complete information is available at [www.michigan.gov](http://www.michigan.gov) or by contacting:

Dr. Steve Halstead, SV

Ph: 517-373-1077

E-mail: [halsteads@michigan.gov](mailto:halsteads@michigan.gov)

USDA/APHIS/VS Office

Dr. Mark Remick

Ph: 517-373-1077

E-mail: [remickm@state.mi.us](mailto:remickm@state.mi.us)

Dr. Jean Ray, SE

Ph: 517-324-5290

E-mail: [jean.s.ray@aphis.usda.gov](mailto:jean.s.ray@aphis.usda.gov)

[\[back to top\]](#)

### Minnesota

All sheep and goats—except animals entering slaughter channels or going to a terminal feedlot—must have an official ear tag upon movement from the flock to another location and before being commingled with sheep and goats from other flocks. Complete information is available by contacting:

Dr William L. Hartmann, SV  
Ph: 651-296-2942  
E-mail: [bill.hartmann@bah.state.mn.us](mailto:bill.hartmann@bah.state.mn.us)

USDA/APHIS/VS Office  
Dr. Dee Heezen  
Ph: 651-290-3691  
E-mail: [dee.m.heezen@aphis.usda.gov](mailto:dee.m.heezen@aphis.usda.gov)

Dr. Kristine Petrini  
Ph: 651-290-3691  
E-mail: [kris.petrini@bah.state.mn.us](mailto:kris.petrini@bah.state.mn.us)

[\[back to top\]](#)

### Mississippi

Federal requirements apply. [Click here to view Federal Requirements](#). Complete information is available by contacting:

Dr. James A. Watson, SV  
Ph: 601-359-1170  
E-mail: [jimw@mdac.state.ms.us](mailto:jimw@mdac.state.ms.us)

USDA/APHIS/VS Office  
Dr. Donald L. Varner  
Ph: 601-965-4307  
E-mail: [donald.l.varner@aphis.usda.gov](mailto:donald.l.varner@aphis.usda.gov)

[\[back to top\]](#)

### Missouri

All breeding sheep 18 months of age or older must have official identification. All goats except low-risk commercial goats must have an official identification. All exhibition sheep and goats regardless of age must have an official approved identification. Identification regulations are in the process of changing, with the most current regulations available at [www.sos.mo.gov/adrules/csr/current/2csr/2c30-2.pdf](http://www.sos.mo.gov/adrules/csr/current/2csr/2c30-2.pdf) or by contacting:

Dr. Taylor Woods, Acting SV  
Ph: 573-751-3377  
E-mail: [taylor.woods@mda.mo.gov](mailto:taylor.woods@mda.mo.gov)

USDA/APHIS/VS Office  
Dr. Alison King  
Ph: 573-636-3116  
E-mail: [alison.o.king@aphis.usda.gov](mailto:alison.o.king@aphis.usda.gov)

Dr. Virginia Shannon  
Ph: 573-636-3116  
E-mail: [virginia.a.shannon@aphis.usda.gov](mailto:virginia.a.shannon@aphis.usda.gov)

Dr. Larry Forgey  
Ph: 573-636-3116  
E-mail: [larry.forgey@mda.mo.gov](mailto:larry.forgey@mda.mo.gov)

[\[back to top\]](#)

### Montana

Federal requirements apply. [Click here to view Federal Requirements](#). Complete information is available by contacting:

Dr. Martin Zaluski, SV  
Ph: 406-444-2043  
E-mail: [mzaluski@mt.gov](mailto:mzaluski@mt.gov)

USDA/APHIS/VS Office  
Dr. Rod Meier  
Ph: 406-449-2220  
E-mail: [rod.s.meier@aphis.usda.gov](mailto:rod.s.meier@aphis.usda.gov)

[\[back to top\]](#)

### Nebraska

Federal requirements apply. [Click here to view Federal Requirements](#). Complete information is available by contacting:

Dr. Dennis Hughes, SV  
Ph: 402-471-2351  
E-mail: [dhughes@agr.ne.gov](mailto:dhughes@agr.ne.gov)  
E-mail: [dwilmot@agr.ne.gov](mailto:dwilmot@agr.ne.gov)

USDA/APHIS/VS Office  
Dr. Gary Stevens  
Ph: 402-434-2300  
E-mail: [gary.e.stevens@aphis.usda.gov](mailto:gary.e.stevens@aphis.usda.gov)

Dr. Thomas J. Schomer  
Ph: 402-434-2300  
E-mail: [tom.schomer@nebraska.gov](mailto:tom.schomer@nebraska.gov)

[\[back to top\]](#)

### Nevada

In addition to Federal requirements, Nevada requires all sheep and goats have official scrapie identification ear tags when they go to fairs and exhibitions. [Click here to view Federal Requirements](#). Complete information is available by contacting:

Dr. Keith Forbes, Nevada Scrapie Coordinator  
Ph: 775-688-1180, Ext. 284  
E-mail: [keith.forbes@agri.state.nv.us](mailto:keith.forbes@agri.state.nv.us)

Sandie Foley, Livestock Permits  
Ph: 775-688-1180, Ext 230

[\[back to top\]](#)

### New Hampshire

Federal requirements apply. [Click here to view Federal Requirements](#). Complete information is available at [www.gencourt.state.nh.us/rsa/html/NHTOC/NHTOC-XL-436.htm](http://www.gencourt.state.nh.us/rsa/html/NHTOC/NHTOC-XL-436.htm) or by contacting:

Dr. Stephen K. Crawford, SV  
Ph: 603-271-2404  
E-mail: [scrawford@agr.state.nh.us](mailto:scrawford@agr.state.nh.us)

USDA/APHIS/VS Office  
Dr. Lech Szkudlarek  
Ph: 508-865-1421, 1422  
E-mail: [lech.szkudlarek@aphis.usda.gov](mailto:lech.szkudlarek@aphis.usda.gov)

[\[back to top\]](#)

### New Jersey

Federal requirements apply. [Click here to view Federal Requirements](#). Complete information is available by contacting:

Dr. Nancy E. Halpern DVM, SV  
Ph: 609-292-3965  
E-mail: [nancy.halpern@ag.state.nj.us](mailto:nancy.halpern@ag.state.nj.us)

USDA/APHIS/VS Office  
Dr. Leslie Bulaga  
Ph: 609-259-8387  
E-mail: [leslie.l.bulaga@aphis.usda.gov](mailto:leslie.l.bulaga@aphis.usda.gov)

[\[back to top\]](#)

### New Mexico

All sheep and goats require official identification except slaughter animals, unless sexually intact, and wethers for exhibition. Complete information is available at [www.newmexicolivestockboard.com](http://www.newmexicolivestockboard.com) or by contacting:

Dr. Dave Fly, Acting SV  
Ph: 505-841-6161  
E-mail: [dave.fly@state.nm.us](mailto:dave.fly@state.nm.us)

USDA/APHIS/VS Office  
Dr. Milo Muller  
Ph: 505-761-3160  
E-mail: [miloslav.muller@aphis.usda.gov](mailto:miloslav.muller@aphis.usda.gov)

[\[back to top\]](#)

### New York

The following sheep and goats must have an official ear tag: 1) animals handled by a dealer; 2) animals being exhibited at a county or state fair; 3) animals more than 18 months of age; 4) animals changing ownership unless in slaughter channels; and 5) sexually intact animals being sold or moved except those sold directly to slaughter plants. Goats and commercial white-faced sheep are not exempt. Complete information is available by contacting:

Dr. John P. Huntley, SV  
Ph: 518-457-3502  
E-mail: [john.huntley@agmkt.state.ny.us](mailto:john.huntley@agmkt.state.ny.us)

USDA/APHIS/VS Office  
Dr. Jessica Keen  
Ph: 518-869-9007  
E-mail: [jessica.n.keen@aphis.usda.gov](mailto:jessica.n.keen@aphis.usda.gov)

[\[back to top\]](#)

### North Carolina

All sheep and goats must have an official ear tag except wethers and animals less than 12 months of age that are moving directly to slaughter. Complete information is available by contacting:

Dr. David T. Marshall, SV  
Ph: 919-733-7601  
E-mail: [david.marshall@ncmail.net](mailto:david.marshall@ncmail.net)

USDA/APHIS/VS Office  
Dr. Leslie Kent  
Ph: 919-855-7700  
E-mail: [leslie.p.kent@aphis.usda.gov](mailto:leslie.p.kent@aphis.usda.gov)

[\[back to top\]](#)

### North Dakota

All sheep and goats require official identification except sheep under 18 months in slaughter channels; goats in slaughter channels; wethers for exhibition; low-risk commercial goats; animals moved for grazing or similar management purposes without change of ownership; and animals shipped directly to an approved slaughter facility or approved market when all the animals in a section of a truck are from the same premises of origin and are accompanied by an owner's statement. Complete information is available by contacting:



Dr. Susan J. Keller, SV  
 Ph: 701-328-2655  
 E-mail: [skeller@nd.gov](mailto:skeller@nd.gov)

Dr. Beth Carlson  
 Ph: 701-328-2655  
 E-mail: [bwcarlson@nd.gov](mailto:bwcarlson@nd.gov)

[\[back to top\]](#)

### Ohio

Sheep and goats—except sheep less than 18 months of age moving into a slaughter channel and goats of any age moving into a slaughter channel—must have an official ear tag, an approved electronic implant or approved tattoo. Complete information is available at <http://codes.ohio.gov/oac/901%3A1-13> or by contacting:

Dr. T. Forshey, Acting SV  
 Ph: 614-728-6220  
 E-mail: [tforshey@mail.agri.state.oh.us](mailto:tforshey@mail.agri.state.oh.us)

USDA/APHIS/VS Office  
 Dr. David Frew  
 Ph: 614-469-5602  
 E-mail: [frew@mail.agri.state.oho.us](mailto:frew@mail.agri.state.oho.us)

Dr. Susan Skorupski  
 Ph: 614-469-5602  
 E-mail: [susan.skorupski@aphis.usda.gov](mailto:susan.skorupski@aphis.usda.gov)

[\[back to top\]](#)

### Oklahoma

All sheep and goats must have an official ear tag prior to moving into a market chain or upon change of ownership. Complete information is available by contacting:

Dr. Becky Brewer, SV  
 Ph: 580-522-6131  
 E-mail: [bbrewer@oda.state.ok.us](mailto:bbrewer@oda.state.ok.us)

USDA/APHIS/VS Office  
 Dr. Nancy Roberts  
 Ph: 405-427-9413  
 E-mail: [nancy.j.roberts@aphis.usda.gov](mailto:nancy.j.roberts@aphis.usda.gov)

[\[back to top\]](#)

### Oregon

Federal requirements apply. [Click here to view Federal Requirements](#). Complete information is available at [www.oregon.gov/ODA/AHID/animal\\_health/import\\_sheep\\_goats.shtml](http://www.oregon.gov/ODA/AHID/animal_health/import_sheep_goats.shtml) or by contacting:

Dr. Donald E. Hansen, SV  
 Ph: 503-986-4680  
 E-mail: [dhansen@oda.state.or.us](mailto:dhansen@oda.state.or.us)

USDA/APHIS/VS Office  
 Dr. Jack Mortenson  
 Ph: 503-399-5871  
 E-mail: [jack.a.mortenson@aphis.usda.gov](mailto:jack.a.mortenson@aphis.usda.gov)

[\[back to top\]](#)

### Pennsylvania

All sheep and goats imported into the Commonwealth of Pennsylvania must have a Pennsylvania Department of Agriculture-approved individual identification. Sheep and goats shipped through the state to another destination and temporarily unloaded from the vehicle or conveyance must have individual identification. All sheep and goats born within the state and transported live from their premises of birth must have individual identification. Complete information is available by contacting the Pennsylvania Department of Agriculture or:

Dr. Paul Knepley., SV  
 Ph: 717-772-2852  
 E-mail: [pknepley@state.pa.us](mailto:pknepley@state.pa.us)

USDA/APHIS/VS Office  
 Dr. Maher Rizk  
 Ph: 717-782-3442  
 E-mail: [maher.a.rizk@aphis.usda.gov](mailto:maher.a.rizk@aphis.usda.gov)

[\[back to top\]](#)

### Rhode Island

All sheep and goats—except those in the slaughter channel—must have an official ear tag when changing ownership or location. Animals entered the state from out of state require unique identification. Sheep and goats need not be identified if they are in a slaughter channel. Complete information is available by contacting:

Dr. Scott Marshall, SV  
 Ph: 401-222-2781  
 E-mail: [scott.marshall@dem.state.ri.us](mailto:scott.marshall@dem.state.ri.us)

USDA/APHIS/VS Office  
 Dr. Lech Szkudlarek  
 Ph: 508-865-1421, 1422  
 E-mail: [lech.szkudlarek@aphis.usda.gov](mailto:lech.szkudlarek@aphis.usda.gov)

[\[back to top\]](#)

**South Carolina**

Federal requirements apply. [Click here to view Federal Requirements](#). Complete information is available by contacting:

Dr. John Caver, SV  
 Ph: 803-788-2260  
 E-mail: [jcaver@clemson.edu](mailto:jcaver@clemson.edu)

USDA/APHIS/VS Office  
 Dr. Virginia Jenkins  
 Ph: 803-788-1919  
 E-mail: [virginia.w.jenkins@aphis.usda.gov](mailto:virginia.w.jenkins@aphis.usda.gov)

[\[back to top\]](#)

**South Dakota**

Federal requirements apply. [Click here to view Federal Requirements](#). Complete information is available at [www.state.sd.us/aib](http://www.state.sd.us/aib) or by contacting:

Dr. Sam D. Holland, SV  
 Ph: 605-773-3321  
 E-mail: [dr.holland@state.sd.us](mailto:dr.holland@state.sd.us)

USDA/APHIS/VS Office  
 Dr. Craig Hanson  
 Ph: 605-773-3321  
 E-mail: [vssd@aphis.usda.gov](mailto:vssd@aphis.usda.gov)

[\[back to top\]](#)

**Tennessee**

All sheep that move outside the state must have an official ear tag. All sheep that move within the state—except wethers under the age of 18 months produced for slaughter only—must have an official ear tag. This includes change of ownership, shows, fairs, expositions, or slaughter. All registered breeding goats, goats commingled with sheep, goats for exhibition and dairy goats moving off the premises of origin must have an official ear tag. This includes change of ownership, shows, fairs, expositions, or slaughter. Complete information is available at <http://tennessee.gov/sos/rules/0080/0080-02/0080-02-01.pdf> or by contacting:

Dr. Ronald B. Wilson, SV  
 Ph: 615-837-5120  
 E-mail: [ron.wilson@state.tn.us](mailto:ron.wilson@state.tn.us)

USDA/APHIS/VS Office  
 Dr. Shelly J. Phillips  
 Ph: 615-781-5310  
 E-mail: [shelly.j.phillips@aphis.usda.gov](mailto:shelly.j.phillips@aphis.usda.gov)

[\[back to top\]](#)

**Texas**

The following sheep must be officially identified with an official ear tag: 1) All breeding sheep regardless of age; 2) All sheep 18 months of age or older; and 3) All sexually intact show or exhibition sheep. All breeding or exhibition goats must be identified with an official ear tag, except registered goats with a registration tattoo and accompanied by registration papers. All goats in slaughter channels must be officially identified, except goats that have not commingled with sheep. Federal requirements apply to intrastate movement. [Click here to view Federal Requirements](#). Complete information is available at [www.tahc.state.tx.us](http://www.tahc.state.tx.us) or by contacting:

Dr. Bob Hillman, SV  
 Ph: (512) 719-0700 or 0777  
 E-mail: [bhillman@tahc.state.tx.us](mailto:bhillman@tahc.state.tx.us)

USDA/APHIS/VS Office  
 Dr. Dan Baca  
 Ph: 512-916-5551 thru 5557  
 E-mail: [daniel.r.baca@aphis.usda.gov](mailto:daniel.r.baca@aphis.usda.gov)

Dr. Brian Bohl  
 Ph: 512-916-5551 thru 5557  
 E-mail: [brian.a.bohl@aphis.usda.gov](mailto:brian.a.bohl@aphis.usda.gov)

Dr. Robert Scott  
 Ph: 512-916-5551 thru 5557  
 E-mail: [robert.a.scott@aphis.usda.gov](mailto:robert.a.scott@aphis.usda.gov)

Dr. Gary Hart  
 Ph: 512-916-5551 thru 5557  
 E-mail: [gary.l.hart@aphis.usda.gov](mailto:gary.l.hart@aphis.usda.gov)

Dr. Andrew Schwartz  
 Ph: 512-916-5551 thru 5557  
 E-mail: [andys@tahc.state.tx.us](mailto:andys@tahc.state.tx.us)

[\[back to top\]](#)

**Utah**

Federal requirements apply. [Click here to view Federal Requirements](#). Complete information is available at [www.rules.utah.gov/publicat/code/r058/r058-001.htm#T8](http://www.rules.utah.gov/publicat/code/r058/r058-001.htm#T8) or by contacting:

Dr. Earl Rogers, SV  
Ph: 801-538-7160  
E-mail: [erogers@utah.gov](mailto:erogers@utah.gov)

USDA/APHIS/VS Office  
Dr. Earl Stoneman  
Ph: 801-524-5010, 5012  
E-mail: [earl.stoneman@aphis.usda.gov](mailto:earl.stoneman@aphis.usda.gov)

[\[back to top\]](#)

### Vermont

In addition to animals covered by federal requirements, all sheep and goats exhibited within the state must have an official ear tag. [Click here to view Federal Requirements](#). Complete information is available by contacting:

Dr. Kerry Rood, SV  
Ph: 802-828-2421  
E-mail: [drrood@agr.state.vt.us](mailto:drrood@agr.state.vt.us)  
E-mail: [tjohnson@agr.state.vt.us](mailto:tjohnson@agr.state.vt.us)

USDA/APHIS/VS Office  
Dr. Lech Szkudlarek  
Ph: 508-865-1421, 1422  
E-mail: [lech.szkudlarek@aphis.usda.gov](mailto:lech.szkudlarek@aphis.usda.gov)

[\[back to top\]](#)

### Virginia

Virginia follows Federal requirements. In addition, Virginia allows livestock markets and sale/show managers to require all animals be identified with official ear tags. [Click here to view Federal Requirements](#). Complete information is available by contacting:

Dr. Richard L. Wilkes, SV  
Ph: 804-786-2483  
E-mail: [richard.wilkes@vdacs.state.va.us](mailto:richard.wilkes@vdacs.state.va.us)

USDA/APHIS/VS Office  
Dr. Kenneth Scheel  
Ph: 804-771-2774  
E-mail: [kenneth.r.scheel@aphis.usda.gov](mailto:kenneth.r.scheel@aphis.usda.gov)

[\[back to top\]](#)

### Washington

Every sheep and goat—unless otherwise exempted—must be identified with a state or federal flock identification number and an identification upon change of ownership, possession, intrastate transport or interstate transport. Animals over 18 months of age as evidenced by eruption of their second incisor in slaughter channels must be identified such that the animal may be traced to its flock of birth. Ewes that have lambed or are pregnant in slaughter channels must be so identified regardless of age. All goats

The following sheep must be officially identified with official USDA scrapie program identification: 1) All breeding sheep; 2) All sexually intact sheep imported for exhibition; and 3) All sheep over 18 months of age. Complete information is available by contacting:

Dr. Leonard E. Eldridge, Acting SV  
Ph: 360-902-1878  
E-mail: [leldridge@agri.wa.gov](mailto:leldridge@agri.wa.gov)

USDA/APHIS/VS Office  
Dr. Thomas J. Brignole  
Ph: 360-753-9430  
E-mail: [thomas.j.brignole@aphis.usda.gov](mailto:thomas.j.brignole@aphis.usda.gov)

Dr. Ben Smith  
Ph: 360-753-9430  
E-mail: [bsmith@agr.wa.gov](mailto:bsmith@agr.wa.gov)

[\[back to top\]](#)

### West Virginia

All sheep and goats must have an official ear tag prior to moving from the premises of origin. Complete information is available at [www.wvagriculture.org](http://www.wvagriculture.org) or by contacting:

Dr. L. Joe Starcher, SV  
Ph: (304) 558-2214  
E-mail: [jstarcher@ag.state.wv.us](mailto:jstarcher@ag.state.wv.us)

USDA/APHIS/VS Office  
Dr. Susan Skorupski  
Ph: 614-469-5062  
E-mail: [susan.skorupski@aphis.usda.gov](mailto:susan.skorupski@aphis.usda.gov)

[\[back to top\]](#)

### Wisconsin

In addition to [federal requirements](#), all sheep and goats imported into Wisconsin must have official identification, regardless of age. All sheep and goats imported for recreational events must also have an import permit. Complete information is available

at [http://www.datcp.state.wi.us/ah/agriculture/animals/movement/sheep\\_goats.jsp](http://www.datcp.state.wi.us/ah/agriculture/animals/movement/sheep_goats.jsp) or by contacting:

Dr. Robert Ehlenfeldt, SV  
Ph: 608-224-4872  
E-mail: [robert.ehlenfeldt@wisconsin.gov](mailto:robert.ehlenfeldt@wisconsin.gov)

USDA/APHIS/VS Office  
Doris Olander  
Ph: 608-270-4000  
E-mail: [doris.olander@aphis.usda.gov](mailto:doris.olander@aphis.usda.gov)

[\[back to top\]](#)

### Wyoming

All sheep imported into Wyoming must have official individual identification. All goats imported for reproductive purposes or recreational events must have official individual identification. Complete information is available at <http://wlsb.state.wy.us/animalhealth.htm> or by contacting:

Dr. Walter Cook, Assistant SV  
Ph: 307-777-6443  
E-mail: [wcook2@state.wy.us](mailto:wcook2@state.wy.us)

USDA/APHIS/VS Office  
John Duncan  
Ph: 307-772-2186  
E-mail: [john.v.duncan@aphis.usda.gov](mailto:john.v.duncan@aphis.usda.gov)

[\[back to top\]](#)

### Federal Requirements

In accordance with the National Accelerated Scrapie Eradication Program, Federal requirements mandate these groups of sheep and goats need an official scrapie USDA-approved eartag or other official identification before being moved from an owner's premises regardless if they are being shipped in-state or out-of-state:

- All breeding sheep and potential breeding sheep regardless of age.
- All sheep 18 months and older.
- All sheep and goats for exhibition except for wethers.
- All scrapie-exposed, suspect, test-positive and high-risk animals.
- Breeding goats except low-risk commercial goats.
- Sheep under 18 months of age in slaughter channels that are females that are pregnant or have aborted or sexually intact animals from a scrapie-infected flock/herd.

The following groups **do not need individual identification** and have no movement restrictions:

- Lambs—ewes, ram lambs and wethers under 18 months of age—moving into slaughter channels, including slaughter only auction markets.
- Goats—wethers, does and bucks of any age—moving into slaughter channels.
- Low-risk commercial goats—those raised for fiber and/or meat; those not registered or exhibited; those they have not been in contact with sheep; those not scrapie positive, not high risk or exposed; those not from an infected or source herd; and those not commingled with other goats at premises that do not meet these criteria.
- Wethers for exhibition.
- Animals moving for grazing when no change of ownership occurs.

**National Scrapie Education Initiative  
National Institute for Animal Agriculture**

13570 Meadowgrass Drive, Suite 201 • Colorado Springs, CO 80921  
Phone: 719-538-8843 • Fax: 719-538-8847  
Email: [scrapie@animalagriculture.org](mailto:scrapie@animalagriculture.org)



# Health

## Additional Resources

### Books

**Sheep and Goat Medicine** Pugh, D.G. 2002. W.B. Saunders Company, Philadelphia, PA. 468 p.

A great gift for a veterinarian. A wealth of information for producers and for veterinarians. Knowledge of veterinary terminology will be helpful in using this book.

### **Small Ruminant Production Medicine and Management Manual**

This reference manual contains video, flow charts, photos, and procedure descriptions that are a must for any sheep and goat owner. Find answers to those everyday questions on management, birthing problems, disease prevention/treatment, the proper use of various products, and much more.

*Infovets.com*

P.O. Box 494

Brigham City, UT 84302

877-424-7838

### **Alternative Treatments for Ruminant Animals**

Dettloff, Paul, DVM. 2004. Acres USA, Austin, TX. 246 p.

This book provides information on natural, organic, and sustainable approaches to animal health. Includes information for sheep and goats.

**Natural Goat Care** Coleby, Pat. 2001. Acres USA, Austin, TX. 371 p.

Fascinating book; Australian author pays much attention to nutrition and to maintaining health organically. Call 1-800-355-5313.

**Goat Medicine, Second Edition** Smith, Mary and David M. Sherman. 2009. Wiley-Blackwell, Baltimore, MD. 888 p.

This book is recommended as a useful gift for a veterinarian. Very scientific; some of the terminology will be understood only by a veterinarian, but a few chapters are very useful to producers.

**Natural Sheep Care** Coleby, Pat. 2006. Acres USA, Austin, TX. 215 p.

This is a natural sheep care book with special attention devoted to breeding for finer wool and meat, land management, and treatment of diseases and other health problems

### **Living With Worms in Organic Sheep Production**

Stockdale, Peter. 2008. Canadian Organic Growers, Inc., Ontario, Canada. 79 p.

An excellent book that covers parasite life cycles, managing pastures and animals to prevent parasitism, and diagnosis and treatment of internal parasites.

### Web sites

#### **American Association of Small Ruminant Practitioners**

[www.aasrp.org](http://www.aasrp.org)

#### **National Scrapie Education Initiative**

[www.eradicatescrapie.org](http://www.eradicatescrapie.org)

#### **Southern Consortium for Small Ruminant Parasite Control**

[www.scsrpc.org](http://www.scsrpc.org)

#### **Pipestone Veterinary Supply**

[www.pipevet.com](http://www.pipevet.com)

# Facilities



In this section:

- Paddock Design, Fencing and Water Systems for Controlled Grazing
- Goat Housing and Equipment
- Sheep Housing, Fencing, Feeders, and Equipment
- Fencing
- Types of Fencing for Goats
- Planning & Building Fences on the Farm
- How to Hotwire a Goat
- Additional Resources

# Paddock Design, Fencing and Water Systems for Controlled Grazing

A Publication of ATTRA—National Sustainable Agriculture Information Service • 1-800-346-9140 • [www.attra.ncat.org](http://www.attra.ncat.org)

By Ron Morrow,  
revised by Alice Beetz  
NCAT Agriculture  
Specialists, 2005  
Updated and Revised  
by Lee Rinehart  
NCAT Agriculture  
Specialist  
© NCAT 2009

## Contents

Introduction.....	1
Forage availability .....	2
Paddock design .....	2
Fencing .....	3
Wire, poly wire and poly tape .....	4
Water systems .....	4
References .....	5
Further resources .....	5
Appendix: Fencing suppliers .....	6

Interest in controlled grazing is increasing throughout the United States. Controlled grazing systems are economically feasible and are now more easily managed because of developments in fencing and water technology. This publication covers some of the basics of paddock design and current fencing and water technology. Paddock design needs to be based on landscape, land productivity, water availability and the number and types of animals in the system. Water systems are more complex and expensive than fencing systems. Producers need to understand all the technology available before establishing a grazing system. A good way to explore the technology is to order catalogs from companies that sell fencing or water systems.



*The paddock to the left was just grazed. Photo by A.E. Beetz, 2005.*

## Introduction

This publication is an introduction to designing a grazing system. Starting a grazing program can be fairly simple. It is usually best for producers to develop a program instead of jumping in and subdividing their farms into paddocks. Dividing existing pastures in half, closing pasture gates or stringing temporary fencing can be a start to controlled grazing. Watching livestock graze, learning to monitor pastures and using temporary fencing for subdivisions all advance the system without exposing the producer to large risks.

Some producers will use temporary fencing to help develop a grazing system, and then put in high-tensile wire after determining the proper location and frequency of rotation. Some equipment and experience are necessary when working with high-tensile wire. For example, a spinning jenny is a must in unrolling the wire. A crimping tool is necessary when working with lower-gauge (thicker) wire, which should be used if deer are a problem. Deer will not break the lower-gauge wire but might break a higher gauge. Some people who work with graziers to establish controlled

## Related ATTRA Publications

Assessing the Pasture Soil Resource

Dairy Production on Pasture

Dung Beetle Benefits in the Pasture Ecosystem

Freeze Protection for Solar-powered Livestock Watering Systems

Managed Grazing in Riparian Areas

Multispecies Grazing

Organic Alternatives to Treated Lumber

Pasture, Rangeland, and Grazing Management

Pastures: Sustainable Management

Pastures: Going Organic

Rotational Grazing

Ruminant Nutrition for Graziers

Solar-powered Livestock Watering Systems

grazing systems prefer to develop water lines first and then do the fencing.

The first considerations, however, are the number of paddocks and their size and shape. Paddock size is determined by the number of animals, the frequency of rotation and how much forage is needed by the type of animal being grazed. For example, some cow-calf operations are never stocked heavily enough to justify a daily rotation because their animals do not have high enough nutrition requirements to justify that much control.

### Stocking rate or stocking density?

*Stocking rate* is the number of animals or animal units on a unit land area over a specified period of time.

*Stocking density* is the number of animals on a unit land area at any instant (Heitschmidt and Taylor, 1991).

For temperate pastures, stocking density may be more important than stocking rate.

Manipulate stocking density by adjusting paddock area to size of existing herd and forage regrowth.

Paddocks should be small enough for uniform forage grazing. Paddocks can then be adjusted in size as the season progresses and forage growth slows down. If you have to keep animals on a paddock for more than five days to graze to a set stubble height, this probably indicates surplus forage, which can occur early in the season. If the animals cannot keep up with forage growth during the early season, consider cutting some of the forage as hay. The livestock can be turned onto the mowed fields after appropriate rest and recovery of the grass.

The following ATTRA publications will help you make some of these decisions:

- *Rotational Grazing*
- *Ruminant Nutrition for Graziers*
- *Pasture, Rangeland, and Grazing Management*
- *Pastures: Sustainable Management*
- *Dairy Production on Pasture*

## Forage availability

It is important to calculate the forage needs of the grazing animals and how much land is necessary for periodic rotations. Iowa State University Extension has educational material that includes useful worksheets for calculating forage availability (ISU, 2009). Generally, a stock rate of 30,000-50,000 pounds of animals for 1 acre over a day works well. This density range is based on how much forage is available, how much the animals will eat in one day and how much residual forage is left in the pasture. If a producer is rotating every three days, the density is 10,000-17,000 pounds of animals for 1 acre for that period. If the animals are high-producing (milk) animals, the lower figure is used. If forage is abundant, the higher figure is used.

### Cow-hand arithmetic simplified

Here is an example of some cow-hand arithmetic:

Thirty 1,100-pound beef animals need about 1 acre of pasture a day. If the animals are rotated twice a week, paddock size should be 3-4 acres each. If, on average, a paddock is ready to be grazed after 30 days of rest, a producer needs 11 paddocks. Remember, a paddock cannot be grazed and rest at the same time. Rest for 30 days plus grazing for three days divided by a three-day rotation requires 11 paddocks. Another way to figure this is to divide the days of rest (30) by the number of days grazing each paddock (3) and add one, or  $30/3+1=11$  paddocks.

The figures above are an example. Producers can use the same calculations with their own figures to determine paddock numbers on their own farms or ranches.

## Paddock design

Most people think of paddocks as flat, symmetrical squares. Unfortunately, most farms are not flat. They have hills, streams and often trees. A general recommendation is to allow cattle access to water within 800 feet of any point on the pasture. Research has shown that if cattle have to walk more than this distance to water, they tend to undergraze farther from the water source.

Cattle also tend to travel to water in groups when a lane is used or when they are far



### How long should animals remain in a paddock?

Use the following principles to determine how long animals should remain on your paddocks:

Prevent grazing of regrowth

Plants may have enough grazable regrowth after six to 12 days

The shorter the period in the paddock, the better the plant and animal production

Protein intake declines the longer the animal is in a paddock.

away from the water. This can be important in determining the type of water system to use. The appropriate distance to water, however, can vary depending on terrain, type of cattle, forage availability and grazing goals of the producer. The recommendation of 800 feet is probably best used in a system designed for maximum forage use.

However, landscape should be considered. Livestock may prefer to graze some slopes or flat areas over other parts of the paddock. If a paddock has a lot of variation in this aspect, it may be poorly used because some areas will be overgrazed and others undergrazed. In this case, it is best to fence according to the landscape or use temporary fencing to control access within the paddock.

When designing a grazing system, also consider differences in the productivity of the land. For example, in a two-day rotation, some paddocks may need to be larger than others to have the same amount of forage available.

## Fencing

Electric fencing is very popular among graziers. Electric fencing systems offer many benefits over conventional wire or wooden fences. Light weight, ease of installation and adaptability characterize electric fencing systems. Electric interior fences (that divide paddocks within a grazing pasture or cell) can be single-stranded poly wire or poly tape with portable posts that can be easily installed and removed to make the paddock bigger or smaller, depending on forage quantity.



*An example of electric fencing using metal T-post. By A. E. Beetz, 2005.*

Some of the necessary equipment for designing and constructing electric fences includes:

- charger (energizer) and grounding rods
- high-tensile wire, 10, 12.5 or 14 gauge
- tensioners and insulators
- poly tape and poly wire for sectioning off paddocks
- tools, including volt meters, crimping devices, lightning arrestors and surge protectors
- posts, such as wood and steel (for permanent and corner braces) and step-in posts (temporary)

The first step in fencing is choosing a low-impedance, high-voltage charger. There are several excellent ones on the market that are powered by the sun, a battery or the power grid. Charger quality varies considerably depending on the make, the size of the battery and the amount of voltage supplied. Proper grounding of the system is absolutely essential to its success. This can be a problem in rocky or very dry soils.

Use fencing system catalogs to compare prices and get an idea of the products and techniques available in fencing and water systems. Several companies have toll-free numbers and will send you catalogs for free. In addition, some companies offer free installation manuals you can download from their Web sites. A list of major suppliers is

included in the **Appendix**. If you call for a catalog, ask about dealers or company representatives in your area. These people can sometimes give you a better deal than the company itself and may provide some practical consultation. Be aware that some custom fencing companies may overbuild fences or use more wires than necessary.

Advances in fencing technology now allow a producer to have greater control over the use and growth of pastures. Water system improvements, such as solar pumps and other devices, enable producers to have enough paddocks to rotate cattle frequently and also have water available in each paddock.

## Wire, poly wire and poly tape

There are many fencing materials available. High-tensile wire offers the most permanent option. In the presence of good perimeter fences and cattle that are trained to respect an electric fence, one strand of wire is effective for interior fences and paddock dividers. The wire should be strung at about shoulder-level of the animals. By having the wire high enough, calves can creep into the next pasture and graze more abundant forage. Having two pinlock insulators on a post and moving the fence to the higher one as calves begin to creep graze is an easy way of managing the system. If using wood posts, fasten the pinlock insulator with staples and not the nails sometimes sold with insulators. Some producers feel that having one wire allows calves to get used to being shocked and makes them harder to handle as yearlings and adults. The greatest advantage of one wire for cattle is that the cattle will eat underneath the wire, whereas with more than one wire grass grows underneath the lowest wire, and can cause the wire to ground out, weakening or eliminating the electrical charge. Three wires will normally control sheep and goats, if the animals are trained to electric fence.

For a more portable system, use poly wire and poly tape. Poly tape is more visible, but the wind can loosen step-in fence posts, particularly when the ground is wet. Some producers, in an effort to save money, use the

wire on electric cord reels. Reels cost about \$5 and can be found at hardware stores. Some producers use high-tensile wire as a feeder wire (carrying electric current to paddock fences) and poly wire to divide pastures into smaller areas as needed. Some producers say that ice on poly wire during the winter can be a problem. One person made the mistake of trying to knock ice off and broke the wire filaments. Again, it is important to try out several of these options to determine what is best for each situation. Pasture walks or farm visits are good ways to find out what other producers are using. Contact your local Cooperative Extension office or National Resources Conservation Service (NRCS) office to see if there are producers in your area willing to host a walk or tour.

**NRCS and Cooperative Extension** phone numbers can be obtained in the federal and county government sections, respectively, of your local telephone directory. Also, you can access local NRCS and Extension directories on the following Web sites:

**Natural Resources Conservation Service**

<http://offices.sc.egov.usda.gov/locator/app?agency=nrcs>

**Cooperative Extension**

[www.csrees.usda.gov/Extension/index.html](http://www.csrees.usda.gov/Extension/index.html)

## Water systems

Water systems should be designed for ease of operation and maintenance. A typical watering system includes a water source (pond, well, municipal water supply), a pump, a pressure gauge, piping and fittings, water troughs and automatic watering valves. Pipe can be made from various kinds of plastic. Black poly plastic is relatively inexpensive, easily to install, comes in 100-foot rolls and can be buried in trenches.

Many producers use gravity flow or solar pump systems with plastic pipe on top of the ground. This works well when the temperature is above 32 degrees Fahrenheit. Pipe made of burst-proof plastic stays intact during the winter without draining. Couplings installed in the pipe at certain intervals can branch off to portable livestock water tanks. Small containers, such as half of a 55-gallon

drum, can water up to 150 head of cattle and have worked well for some producers. Make sure that water is being replenished as fast as it is being consumed. Otherwise, the cattle will tear up the system. A watering system made up of an automatic float valve that discharges 5-8 gallons of water a minute and a water supply pipe larger than 1.25 inches in diameter is adequate for replenishing the water in the tank.

Some devices, such as automatic float valves, are hard to keep clean, so you may want to use a strainer or filter when using pond or creek water.

The accompanying **Appendix** is a list of product distributors. Call to request catalogs. This will help you evaluate the differences in price, and you will also find the catalogs educational. Most offer shortcuts that you can use and give helpful information on how to install fencing and water systems.



*Floating pipe and electric fencing limit livestock access to the pond. By A. E. Beetz, 2005.*

## References

ISU. 2009. Pasture Management Guide for Livestock Producers. Iowa State University Extension. [www.extension.iastate.edu/Publications/PM1713B.pdf](http://www.extension.iastate.edu/Publications/PM1713B.pdf).

Heitschmidt, R.K. and C.A. Taylor. 1991. Livestock Production, in *Grazing Management: an Ecological Perspective*. Portland, OR: Timber Press.

## Further resources

Blanchet, Kevin, Howard Moechnig, and Jodi DeJong-Hughes. 2003. *Grazing Systems Planning Guide*. University of Minnesota Extension Service. [www.extension.umn.edu/distribution/livestocksystems/components/DI7606.pdf](http://www.extension.umn.edu/distribution/livestocksystems/components/DI7606.pdf)

*This guide discusses the components of a grazing system by taking you through the grazing management planning process. Information on grazing resource*

*inventory, plan development, pasture management and system monitoring is provided.*

Electric Fencing for Serious Graziers. 2005. Columbia, MO: Missouri Natural Resources Conservation Service. 2005. [www.mo.nrcs.usda.gov/news/news/MO%20NRCS%20Electric%20Fencing\\_low.pdf](http://www.mo.nrcs.usda.gov/news/news/MO%20NRCS%20Electric%20Fencing_low.pdf)

*Techniques described here are primarily for producers installing one-wire and two-wire fences and permanent power stations using 110-volt energizers.*

Watering Systems for Serious Graziers. 2006. Columbia, MO: Missouri Natural Resources Conservation Service. [www.mo.nrcs.usda.gov/news/images/Watering%20Systemslow.pdf](http://www.mo.nrcs.usda.gov/news/images/Watering%20Systemslow.pdf)

*This publication provides livestock producers with the basic information that they need to plan, design and install water systems that will maximize animal performance and minimize the labor necessary to care for their herds' water needs.*

Pfost, Donald, James Gerrish, Maurice Davis and Mark Kennedy. 2007. Pumps and Watering Systems for Managed Beef Grazing. University of Missouri Extension. <http://extension.missouri.edu/publications/DisplayPub.aspx?P=EQ380>.

*This publication covers such topics as water quality, distribution systems, specifications for pipe and tank*

*and pump sizes, and includes a comprehensive resource list for supplies including solar pumps.*

Fencing and Watering, in The Northeast Grazing Guide. University of Maine Cooperative Extension. [www.umaine.edu/grazingguide/Extension%20Resource%20Topics/fencing\\_and\\_watering.htm](http://www.umaine.edu/grazingguide/Extension%20Resource%20Topics/fencing_and_watering.htm).

*Links to Cooperative Extension publications and resources from several states.*

## Appendix: Fencing suppliers

---

Cameo Fencing  
1-800-822-5426  
[www.cameofencing.com](http://www.cameofencing.com)

Gallagher Power Fence  
1-800-531-5908  
(210) 494-5211  
[www.gallagherusa.com](http://www.gallagherusa.com)

Gallagher POWER FENCE Manual  
[www.gallagherusa.com/pf.manual.aspx](http://www.gallagherusa.com/pf.manual.aspx)

Geotek, Inc.  
1-800-533-1680  
(507) 533-6076  
[www.geotekinc.com](http://www.geotekinc.com)

Kencove Farm Fence  
1-800-536-2683  
[www.kencove.com/fence](http://www.kencove.com/fence)

Kentucky Graziers Supply  
1-800-729-0592  
(859) 987-0215  
<http://kygraziers.com/kgshop>

McBee Agri Supply, Inc.  
1-800-568-4918  
(573) 696-2517

Pasture Management Systems, Inc.  
1-800-230-0024  
[www.pasturemgmt.com](http://www.pasturemgmt.com)

Premier 1 Fence Supplies  
1-800-282-6631  
[www.premier1supplies.com](http://www.premier1supplies.com)

Southwest Power Fence  
1-800-221-0178  
[www.swpowerfence.com](http://www.swpowerfence.com)

Speedrite Agri-Systems  
1-800-323-7306  
[www.speedrite.com](http://www.speedrite.com)

Twin Mountain Fence Co.  
1-800-527-0990  
[www.twinmountainfence.com](http://www.twinmountainfence.com)

*(Source: Stockman Grass Farmer's Grazier's Resource Guide)*

## Notes:

---

**Paddock Design, Fencing and Water Systems for  
Controlled Grazing**

Updated and Revised by Lee Rinehart  
NCAT Agriculture Specialist  
© 2009 NCAT

Holly Michels, Editor  
Amy Smith, Production

This publication is available on the Web at:  
[www.attra.ncat.org/attra-pub/paddock.html](http://www.attra.ncat.org/attra-pub/paddock.html)  
or  
[www.attra.ncat.org/attra-pub/PDF/paddock.pdf](http://www.attra.ncat.org/attra-pub/PDF/paddock.pdf)

IP152  
Slot 50  
Version 010510



### **Idea Plan Goat Housing and Equipment**

**No. IP 728-26**

This Idea Plan is intended to provide educational information and ideas concerning housing and equipment for small herds of goats. The following attached drawings are based on historical plans and may not meet design and construction standards for your area:

Feed Racks for Goats (PSU 99)  
Milk House, Milking Room & Milking Stand for Goats (PSU 100)  
Walk-Thru Milking Parlor for Goats (PSU 101)  
Loose Housing for 20 Goats & Kids (PSU 102)  
Goat and Kid Barn (PSU 103)  
Buck Barn (PSU 104)  
Keyhole Goat Feeder (PSU 390)  
Goat Tie Stall (PSU 391)  
Buck (Goat) Yard (PSU 392)  
Freestall Barn for Goats - 30 Milkers (PSU 394)  
Tie Stall Barn for Goats - 30 Milkers (PSU 395)  
Milking Barn and Milkhouse for 10 Goats (USDA 6255)  
Milking Barn and Milkhouse for 10 Goats (USDA 6256)

If you decide to build a facility similar to any of these plans, be sure to check building requirements for your area. Your local building inspector, engineer, building supplier, or building contractor can help you determine what is a safe and legal facility for goats in your area. In addition to the rules and regulations covering design and construction of buildings, be sure to consider how you will handle the manure and potential nuisance problems for neighbors, including flies, odor, and noise.

The Department of Agricultural and Biological Engineering at Penn State has a variety of educational material available related to agricultural and biological engineering. This material is intended to help Pennsylvania farmers and others develop buildings and facilities for modern, environmentally-compatible farm facilities. The material can be used in conjunction with county extension staff, builders, suppliers, consulting engineers, the Natural Resources Conservation Service, financial management advisors, farm lenders, veterinarians, and others to assemble a facilities plan suitable for local conditions.

Publications are available in the areas of agricultural safety and health, animal housing systems, building and farmstead planning, crops and greenhouses, machinery systems and tractors, residential housing, soil and water resources, and solid waste management. Contact your county Penn State Extension Office for more information on these subjects. You can also obtain an index of publications concerning the above areas by calling, writing, faxing or e-mailing:

Department of Agricultural and Biological Engineering  
246 Agricultural Engineering Building  
University Park, PA, 16802-1909  
Telephone: (814)865-7685  
Fax: (814)863-1031  
E-mail: [abe@psu.edu](mailto:abe@psu.edu).  
[www.abe.psu.edu/factseets](http://www.abe.psu.edu/factseets)

(over)

For more information, the following comprehensive handbook covering design and construction of small pole buildings is available:

NRAES-01—Pole and Post Buildings, Design and Construction (1984).  
\$6.00 (Contact office below for current pricing).

Order from NRAES, Cooperative Extension, B-16 Morrison Hall, Ithaca, NY14853  
(607)255-7654 FAX: (607)254-8770 Email: NRAES@cornell.edu

Information may also be obtained by contacting the following:

American Dairy Goat Association  
P.O. Box 865  
Spindale, NC 28160  
Phone: 704-286-3801, Fax: 704-287-0476, Email: ADGAJDW2@aol.com

---

This publication is available in alternative media on request.

The Pennsylvania State University is committed to the policy that all persons shall have equal access to programs, facilities, admission, and employment without regard to personal characteristics not related to ability, performance, or qualifications as determined by University policy or by state or federal authorities. The Pennsylvania State University does not discriminate against any person because of age, ancestry, color, disability or handicap, national origin, race, religious creed, sex, sexual orientation, or veteran status. Direct all inquiries regarding the nondiscrimination policy to the Affirmative Action Director, The Pennsylvania State University, 201 Willard Building, University Park, PA 16802-2801; tel. (814) 863-0471; TDD (814) 865-3175.



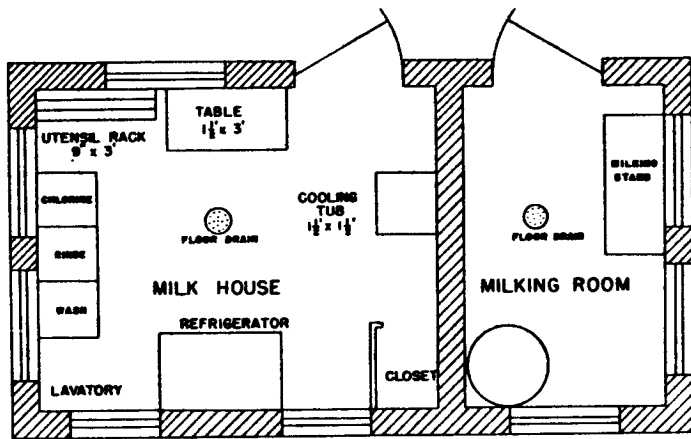

FLOOR PLAN

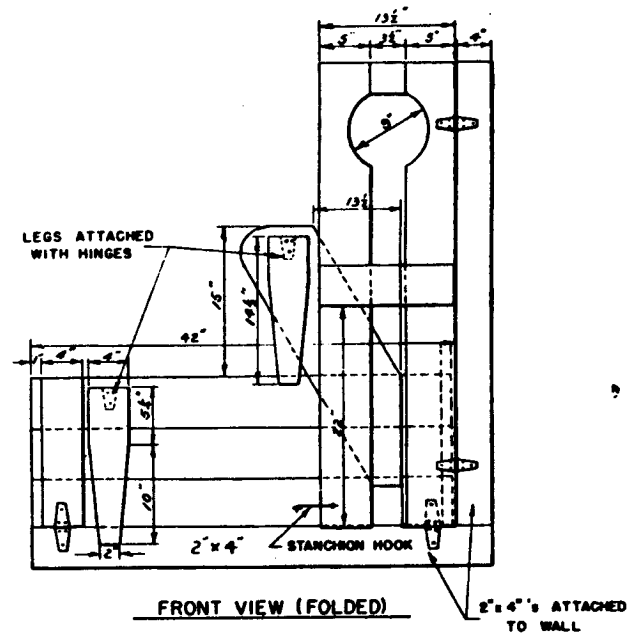

FRONT VIEW (FOLDED)

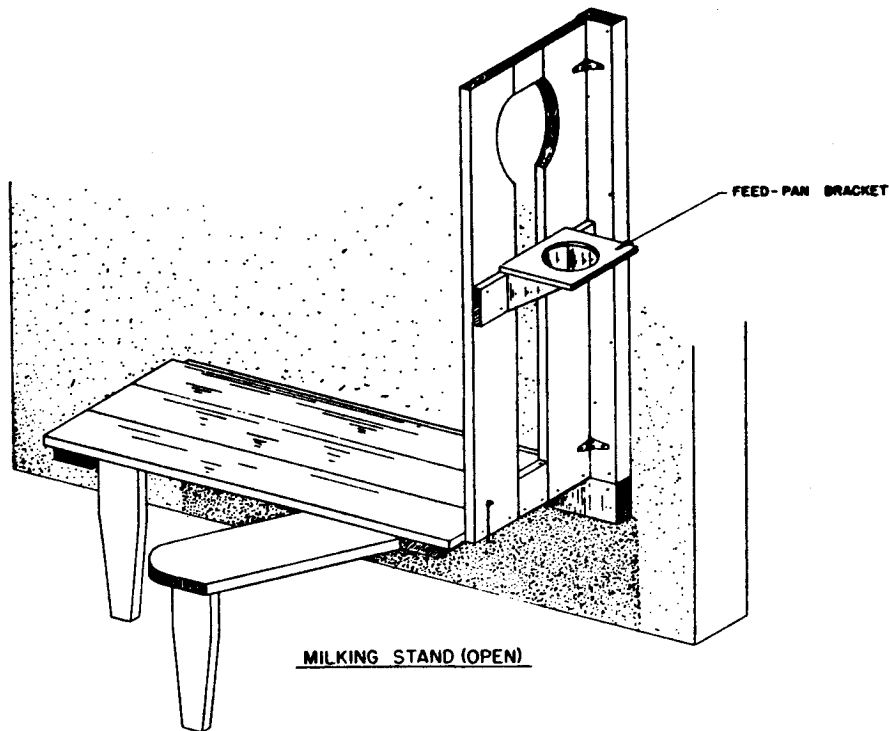

MILKING STAND (OPEN)

NOTE: MILK HOUSE AND MILKING ROOM FLOORS TO BE OF SMOOTH CONCRETE.

WALLS MAY BE OF BLOCK OR FRAME CONSTRUCTION

TO BE USED WITH:

DAIRY GOAT CORRESPONDENCE COURSE 105  
LESSON NO. 5

THE PENNSYLVANIA STATE UNIVERSITY AGRICULTURAL EXTENSION SERVICE	
MILK HOUSE, MILKING ROOM, & MILKING STAND FOR GOATS	

ORDER NO 728-100

SHEET 1 OF 1

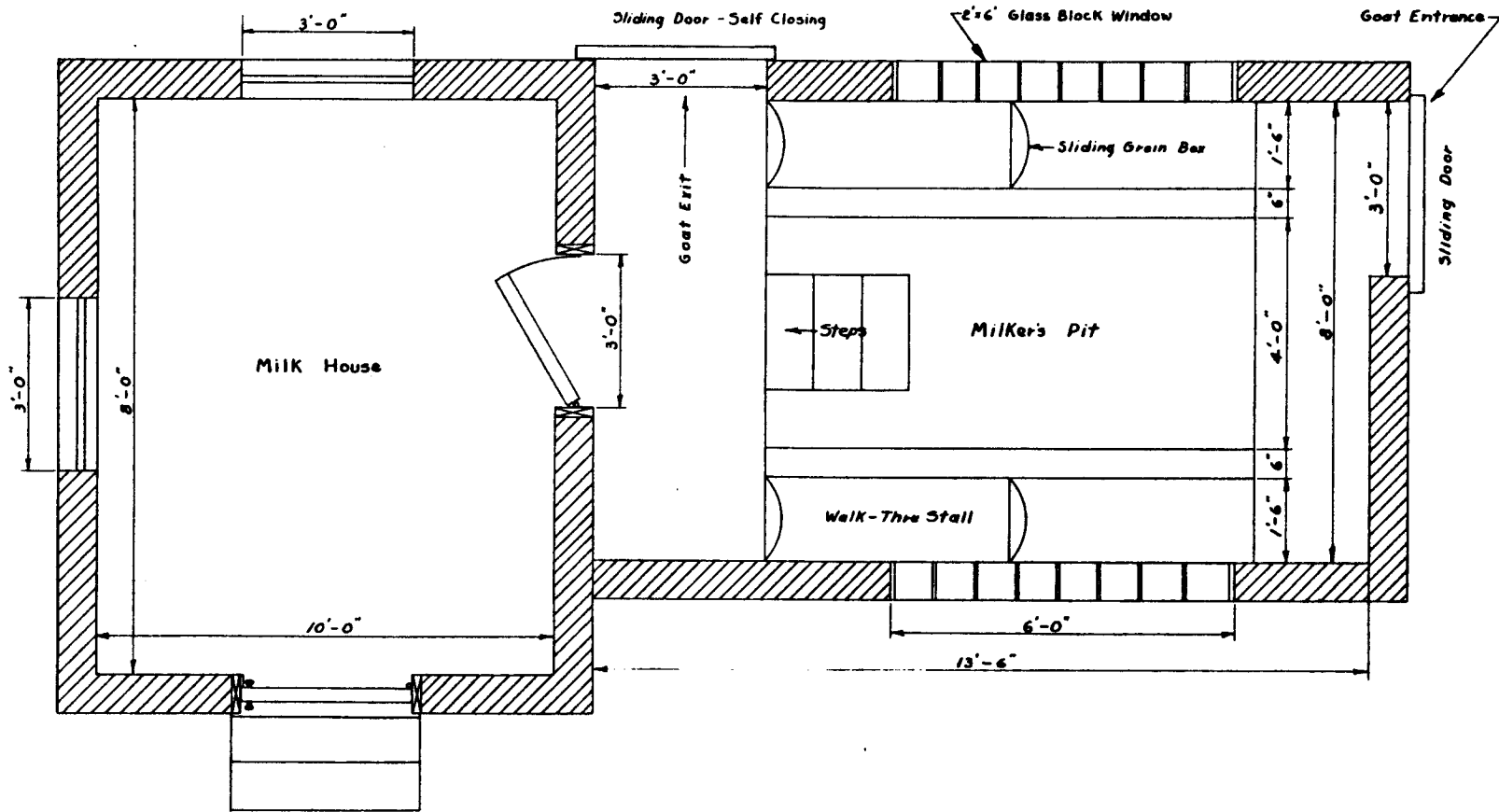

FLOOR PLAN

TO BE USED WITH:  
DAIRY GOAT CORRESPONDENCE COURSE 105  
LESSON NO. 5

THE PENNSYLVANIA STATE UNIVERSITY  
 AGRICULTURAL EXTENSION SERVICE

**WALK-THRU  
 MILKING PARLOR FOR GOATS**

ORDER NO. 728-101

SHEET 1 OF 1

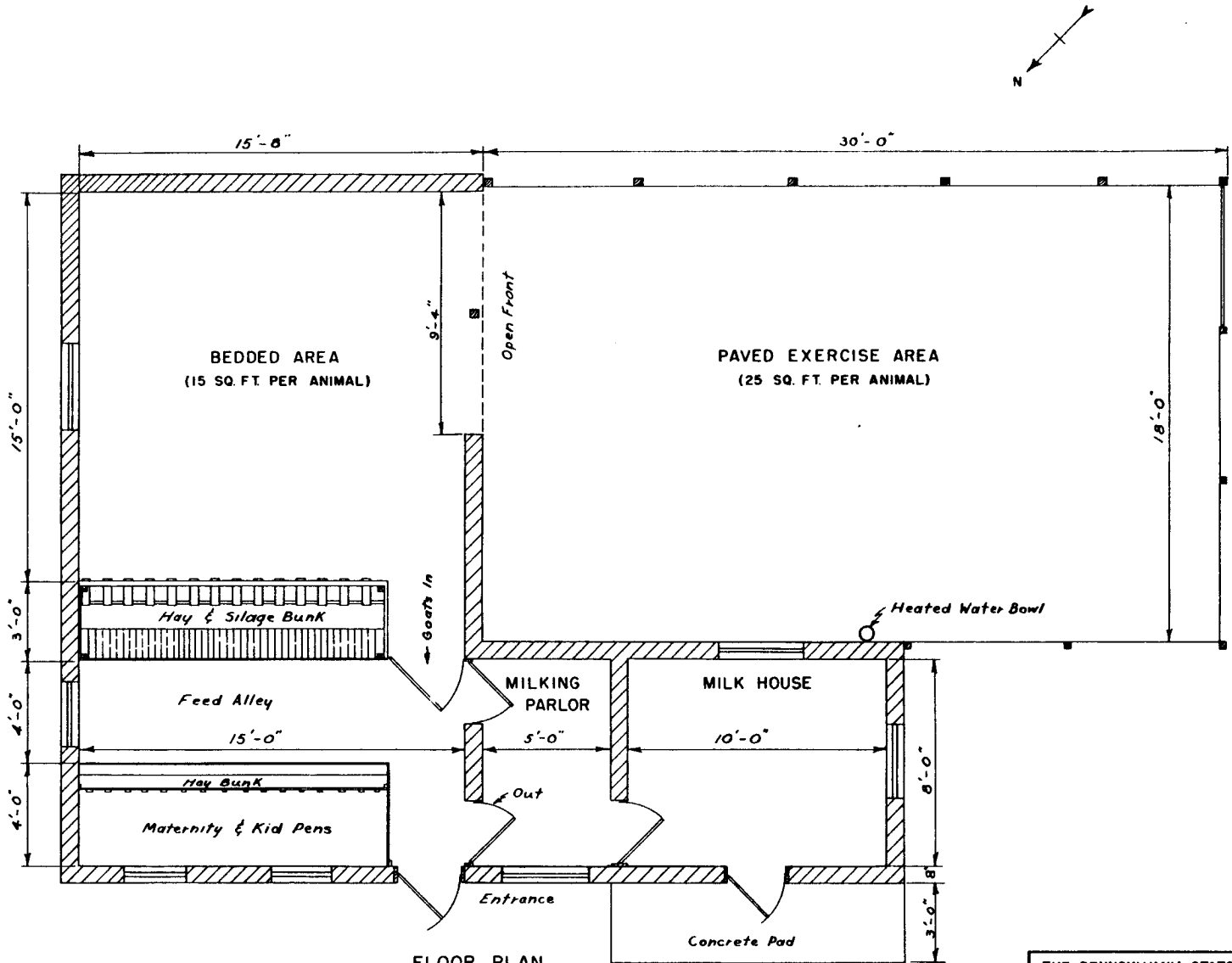

**FLOOR PLAN**

TO BE USED WITH:  
**DAIRY GOAT CORRESPONDENCE COURSE 105**  
**LESSON 5**

THE PENNSYLVANIA STATE UNIVERSITY AGRICULTURAL EXTENSION SERVICE	
<b>LOOSE HOUSING FOR 20 GOATS &amp; KIDS</b>	
ORDER NO 728-102	SHEET 1 OF 1

26/7/59

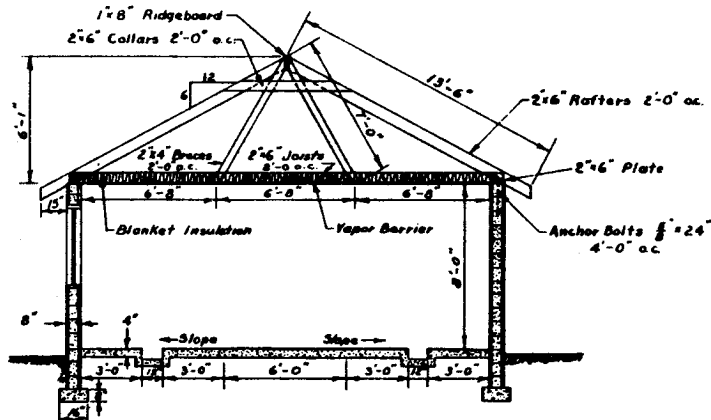

**CROSS SECTION A-A**

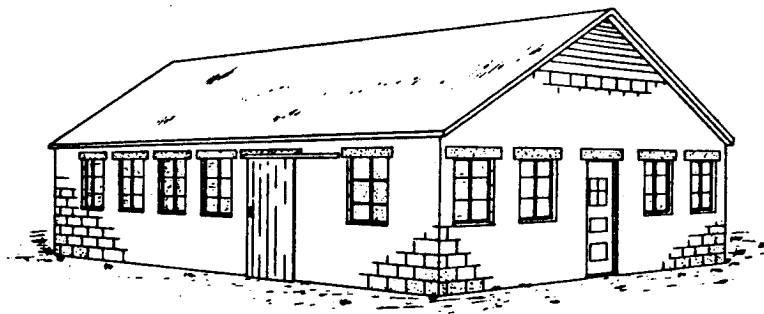

**PERSPECTIVE**

*Note:*  
For large goats stall width may  
be increased to 2'-6".

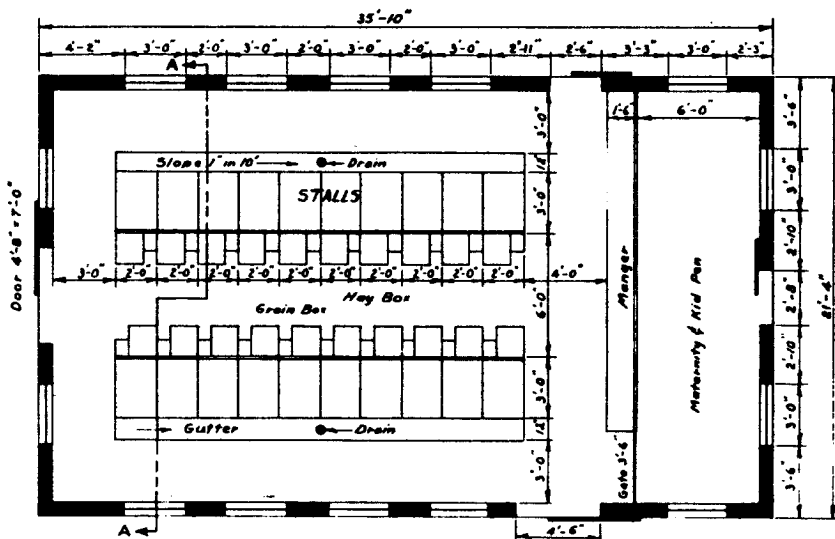

**FLOOR PLAN**

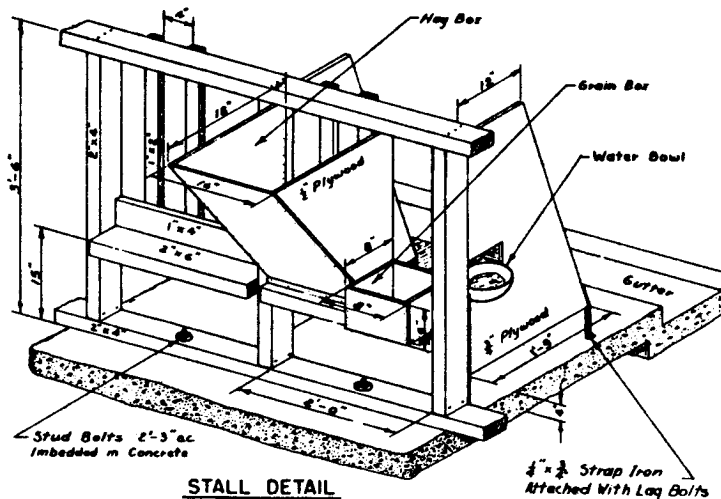

**STALL DETAIL**

THE PENNSYLVANIA STATE UNIVERSITY  
AGRICULTURAL EXTENSION SERVICE

**GOAT AND KID BARN**

TO BE USED WITH:  
DAIRY GOAT CORRESPONDENCE COURSE  
LESSON NO. 5

ORDER NO. 728-103

SHEET 1 OF 1

2/17/50

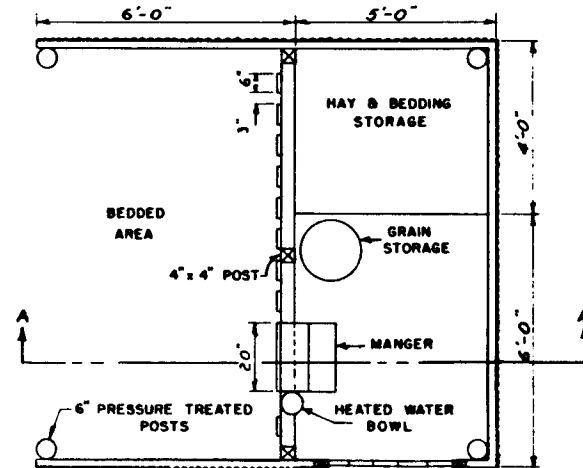
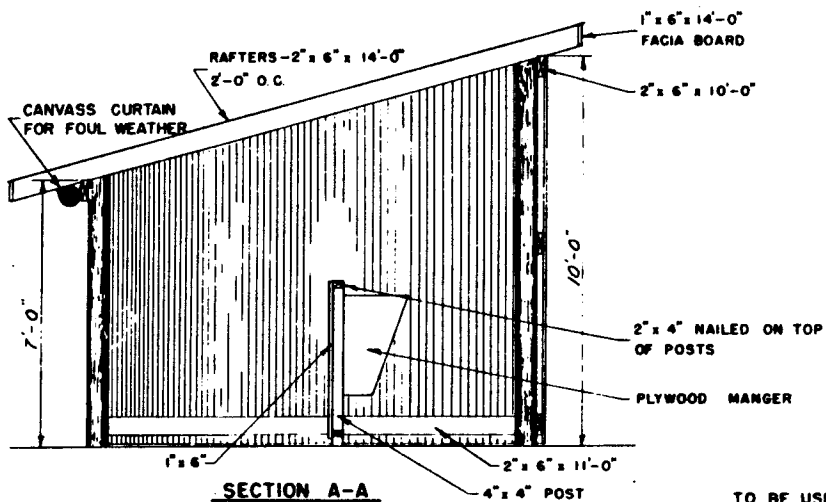
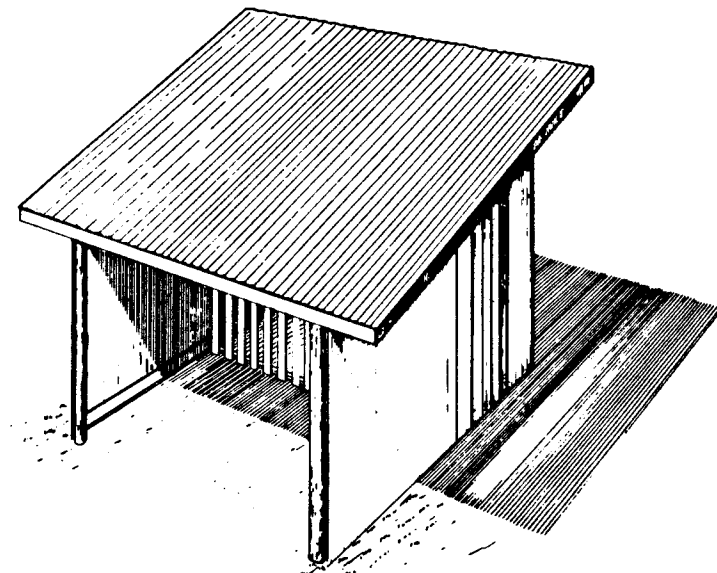
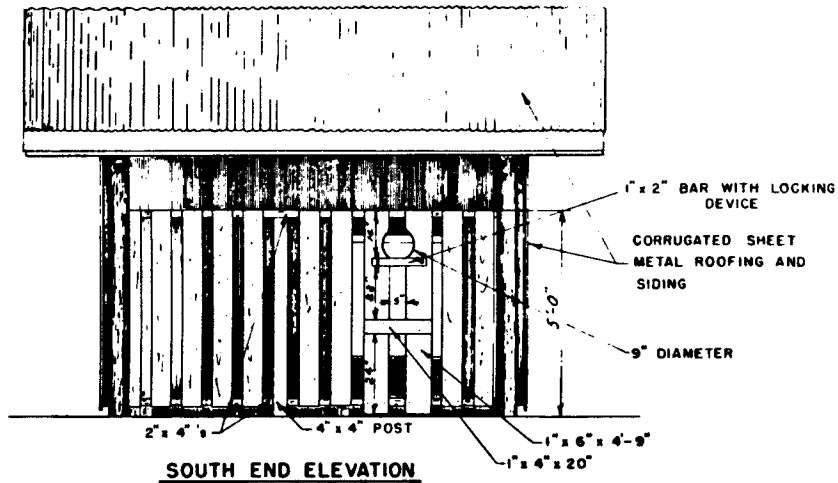

TO BE USED WITH:

DAIRY GOAT CORRESPONDENCE COURSE 105

LESSON NO. 4

THE PENNSYLVANIA STATE UNIVERSITY  
AGRICULTURAL EXTENSION SERVICE

**BUCK BARN**

ORDER NO. 728-104

SHEET 1 OF 1

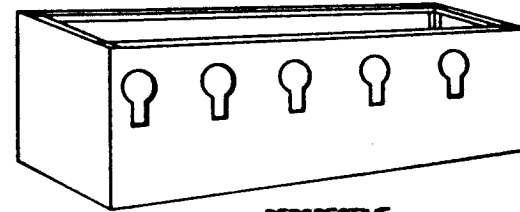
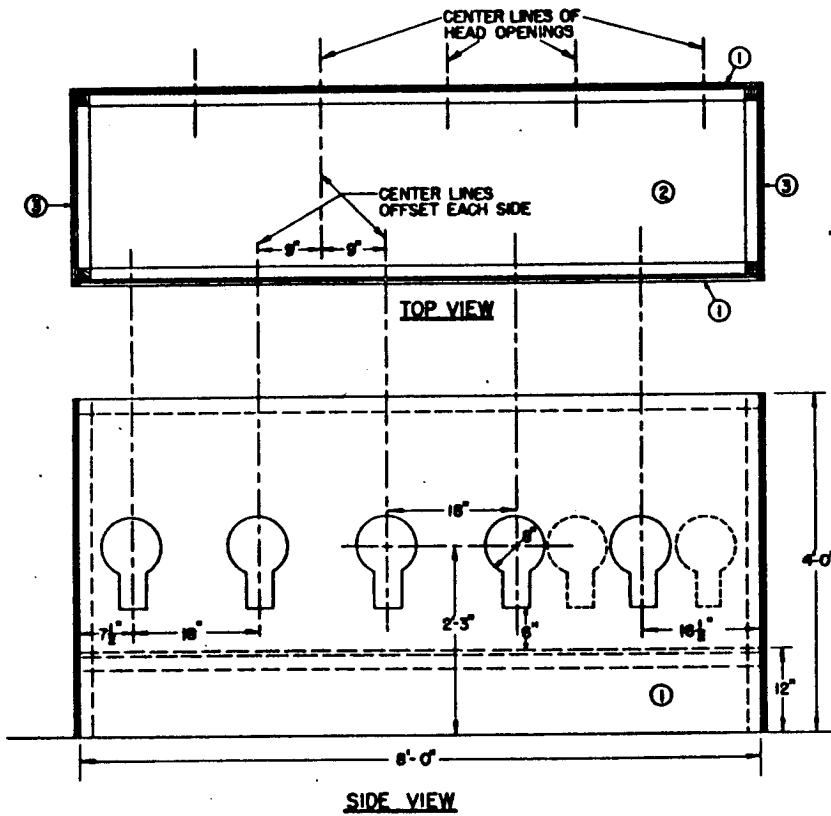

PERSPECTIVE

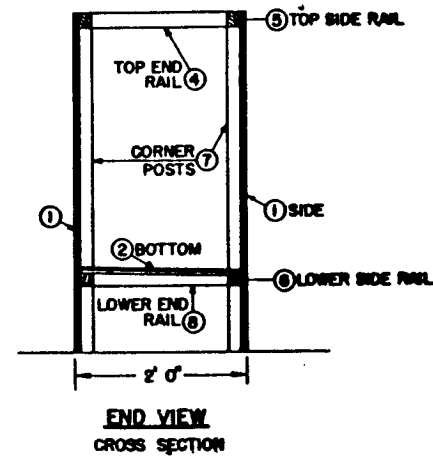

END VIEW  
CROSS SECTION

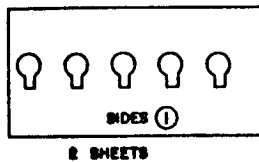

2 SHEETS

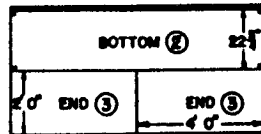

1 SHEET

**CUTTING DIAGRAM FOR PLYWOOD**  
USE 1/2" EXTERIOR PLYWOOD

**LIST OF MATERIALS 8' UNIT, 10 GOATS**

- ① ② ③ 1/2" EXTERIOR PLYWOOD
- ④ ⑧ END RAILS 4 PIECES 2x2x24'
- ⑤ ⑥ SIDE RAILS 4 PIECES 2x2x8'-0"
- ⑦ CORNER POSTS 4 PIECES 2x2x3'-0"

USE GALVANIZED NAILS

THE PENNSYLVANIA STATE UNIVERSITY  
COOPERATIVE EXTENSION SERVICE

**KEYHOLE GOAT FEEDER**

DESN BY: A.R.B.  
TRCD BY: K.H.  
DATE: APRIL, 1977

ORDER NO.  
728-390

SHEET  
1 OF 1

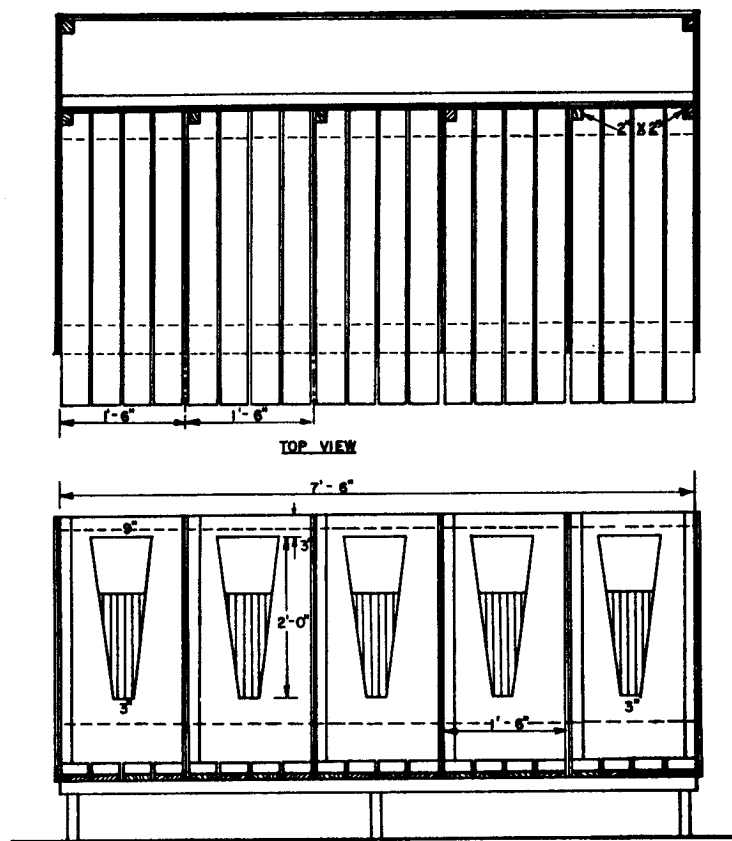

TOP VIEW

REAR VIEW

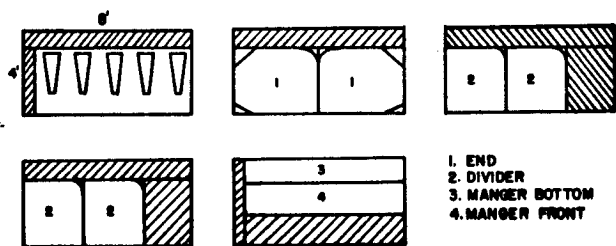
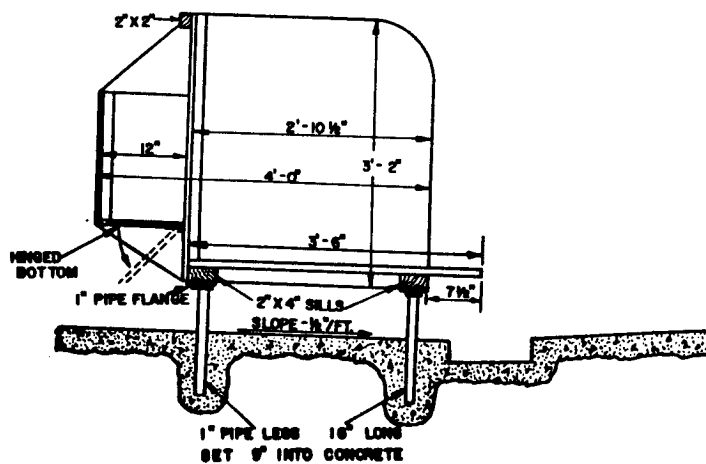

PLYWOOD CUTTING DIAGRAM

- 1. END
- 2. DIVIDER
- 3. MANGER BOTTOM
- 4. MANGER FRONT

THE PENNSYLVANIA STATE UNIVERSITY COOPERATIVE EXTENSION SERVICE		
GOAT TIE STALL		
DRN BY: ARS	ORDER NO.	SHEET
TRCD BY: ARS	728-391	1 OF 1
DATE: MAR, 1977		

**FRONT VIEW OF FEEDER**

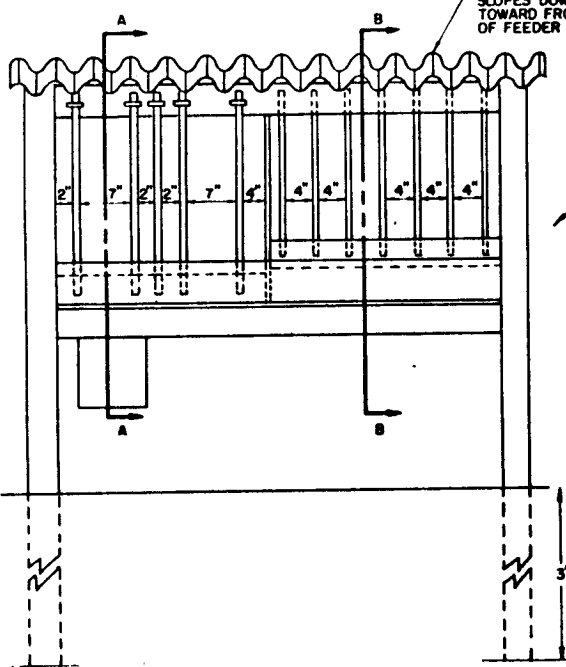

CORRUGATED ROOF SLOPES DOWN TOWARD FRONT OF FEEDER

**SECTION A-A**

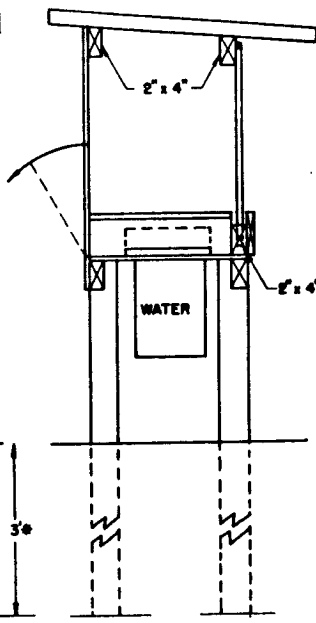

**SECTION B-B**

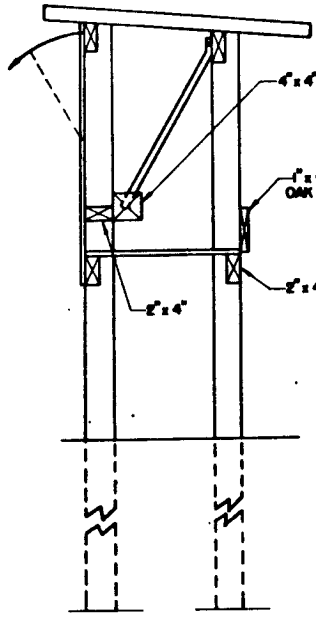

**BACK VIEW OF FEEDER (REAR COVERING OMITTED FOR CLARITY)**

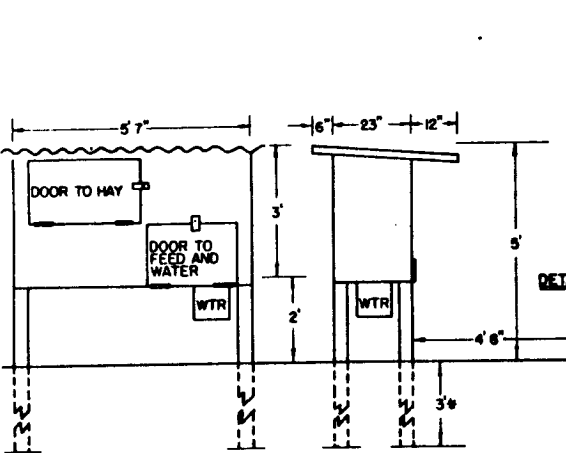
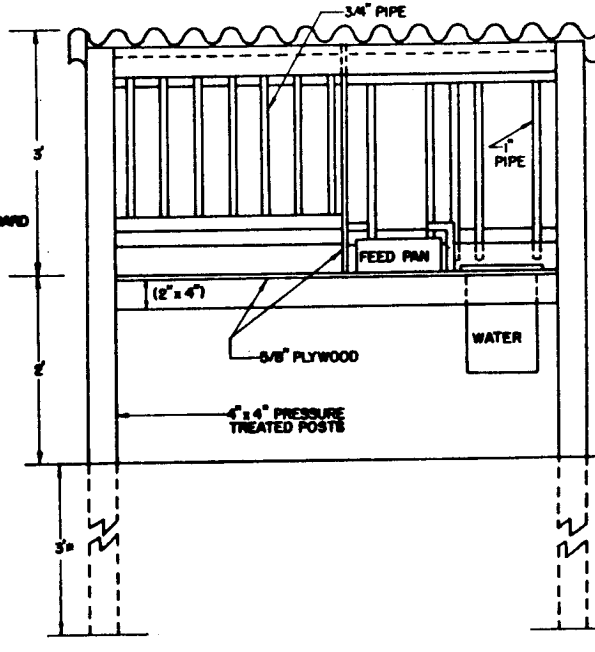

**BACK VIEW OF FEEDER**

**SIDE VIEW OF FEEDER**

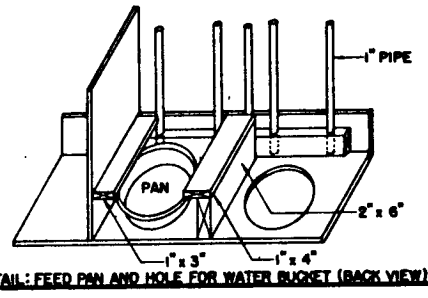

**DETAIL: FEED PAN AND HOLE FOR WATER BUCKET (BACK VIEW)**

**NOTES:** ALL EXPOSED WOOD EDGES SHOULD BE COVERED WITH PROTECTIVE METAL OR HARDWARE CLOTH

USE PIPE CLAMPS OR TINNERS TAPE TO ATTACH TOP ENDS OF PIPE ALONG HAY RACK AND FEED AREA.

\* DEPTH OF SUPPORT POSTS SHOULD BE 3' MINIMUM OR BELOW THE FROST LINE

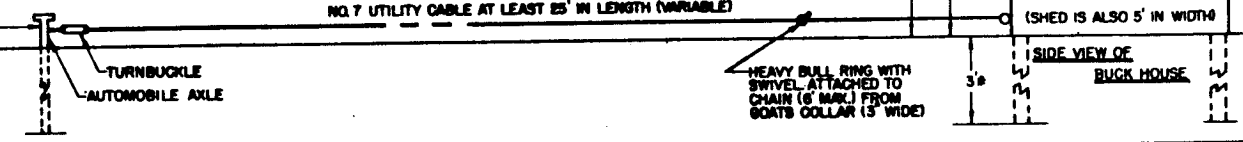

BUCK HOUSE ENCLOSED (3 SIDES) WITH AIR TIGHT SIDING (PLYWOOD, SLABWOOD, OR EQUIVALENT)

1' HIGH VENTILATION PANEL RUNS FULL WIDTH OF SHED.

(SHED IS ALSO 5' IN WIDTH)

**SIDE VIEW OF BUCK HOUSE**

**FEEDER:** BACK AND SIDES ARE ENCLOSED WITH 5/8" PLYWOOD

THE PENNSYLVANIA STATE UNIVERSITY  
COOPERATIVE EXTENSION SERVICE

**BUCK (GOAT) YARD**

DES BY: SA/BRB  
DWN BY: KMH  
DATE: 3/24/77

ORDER NO.  
728-392

SHEET 1 OF 1



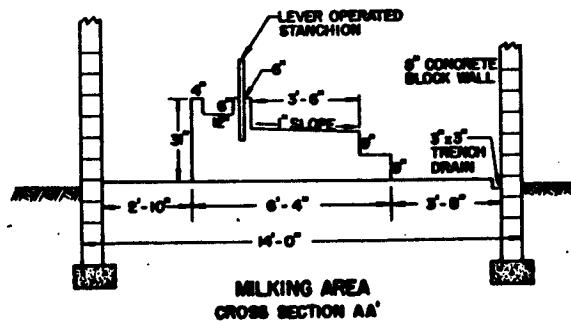
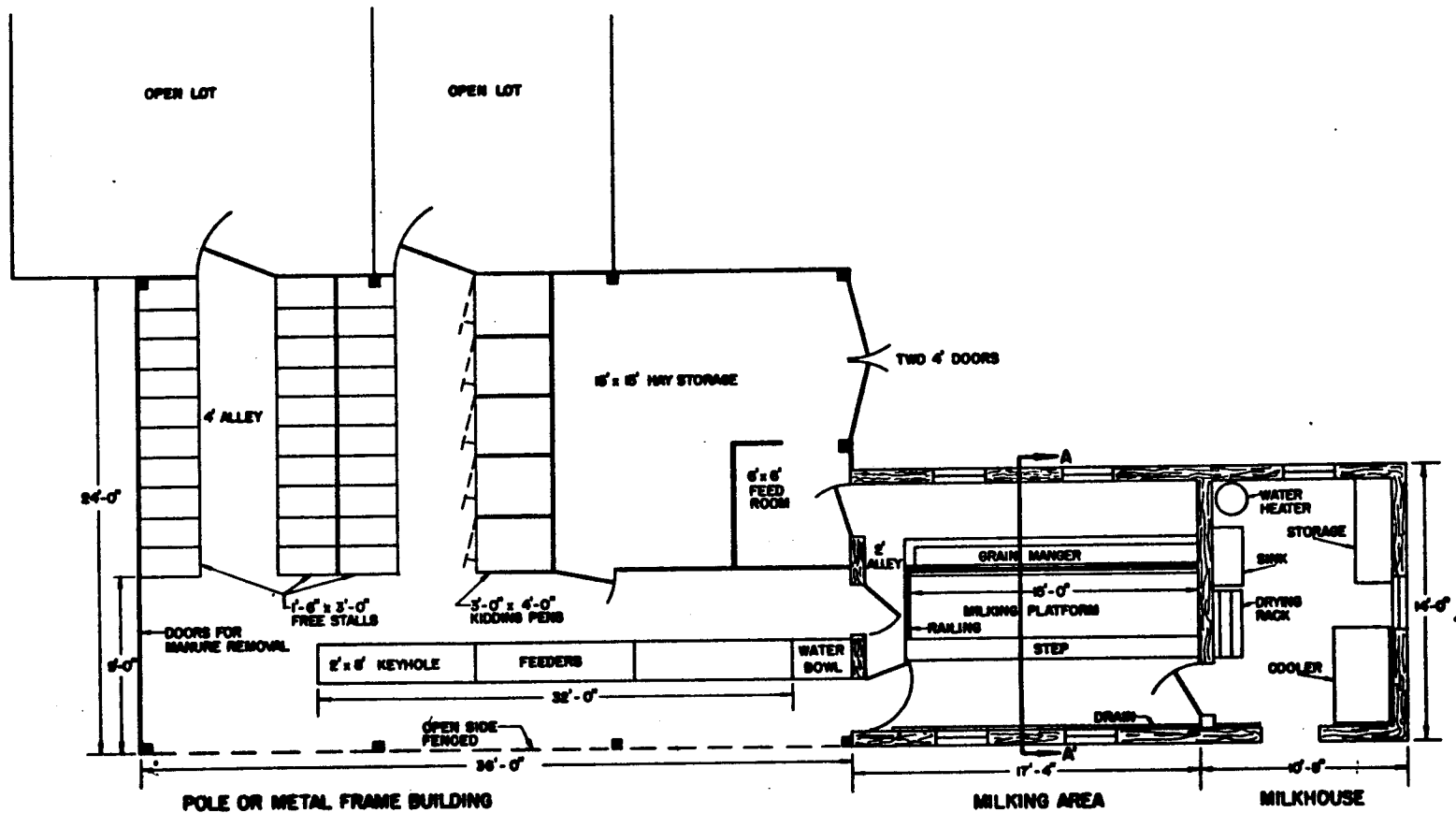

THE PENNSYLVANIA STATE UNIVERSITY COOPERATIVE EXTENSION SERVICE		
<b>FREE STALL BARN          FOR GOATS-30 MILKERS</b>		
DRAWN BY: S.S./A.R.S. TROD BY: K.J. DATE: APRIL 1977	ORDER NO. 728-394	SHEET 1 OF 1

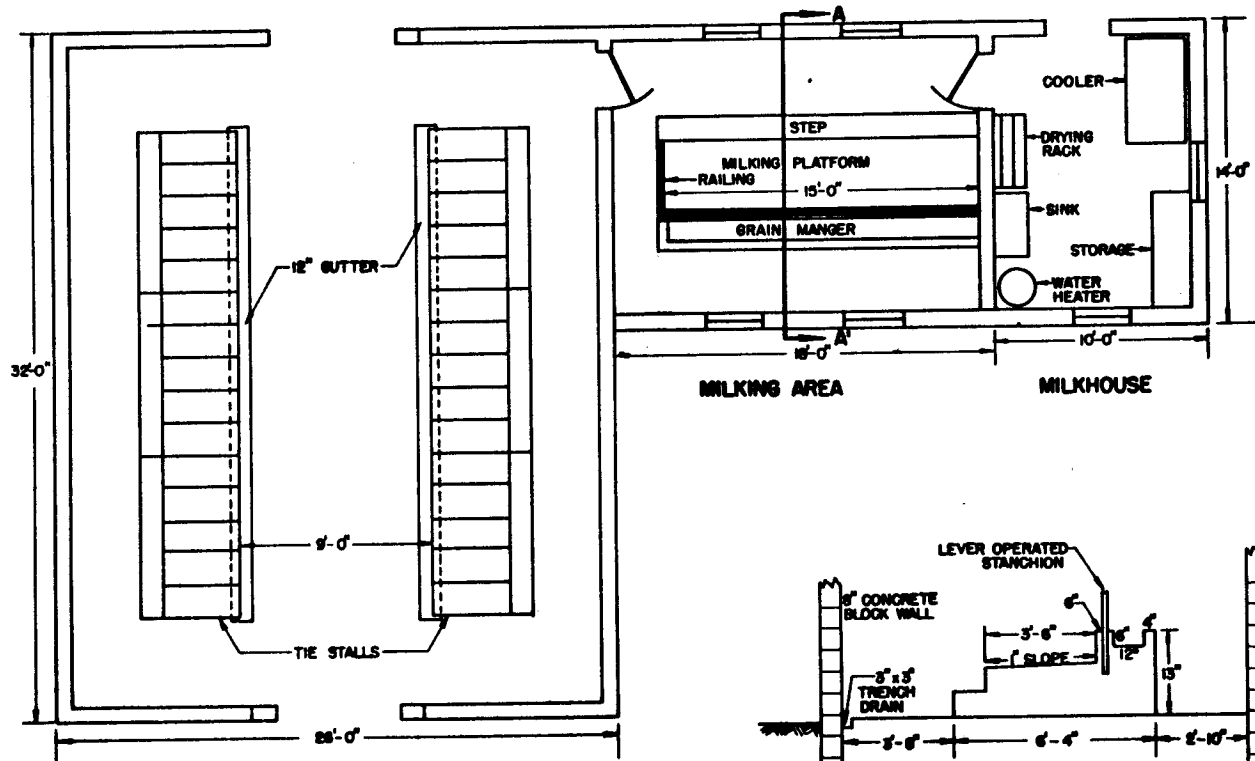

2 STORY BARN  
HAY STORAGE ON 2nd FLOOR

MILKING AREA

MILKHOUSE

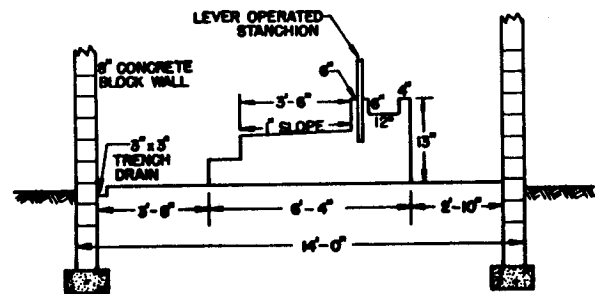

MILKING AREA  
CROSS SECTION AA'

THE PENNSYLVANIA STATE UNIVERSITY COOPERATIVE EXTENSION SERVICE		
<b>TIE STALL BARN FOR GOATS-30 MILKERS</b>		
DRN BY SA/ARS TRCD BY: KM DATE: APRIL 1977	ORDER NO. 728 395	SHEET 1 OF 1

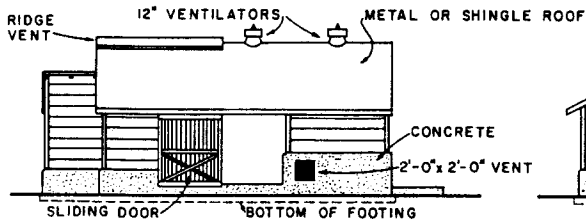

NORTH ELEVATION

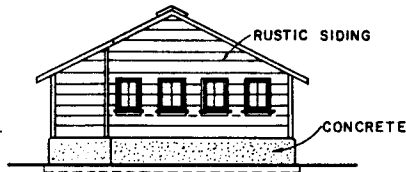

EAST ELEVATION

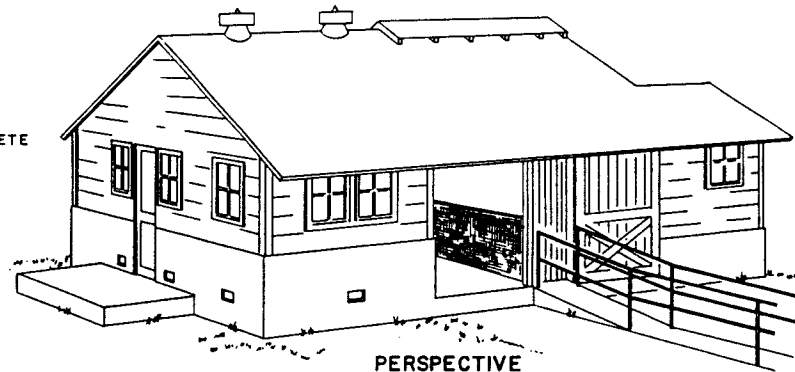

PERSPECTIVE

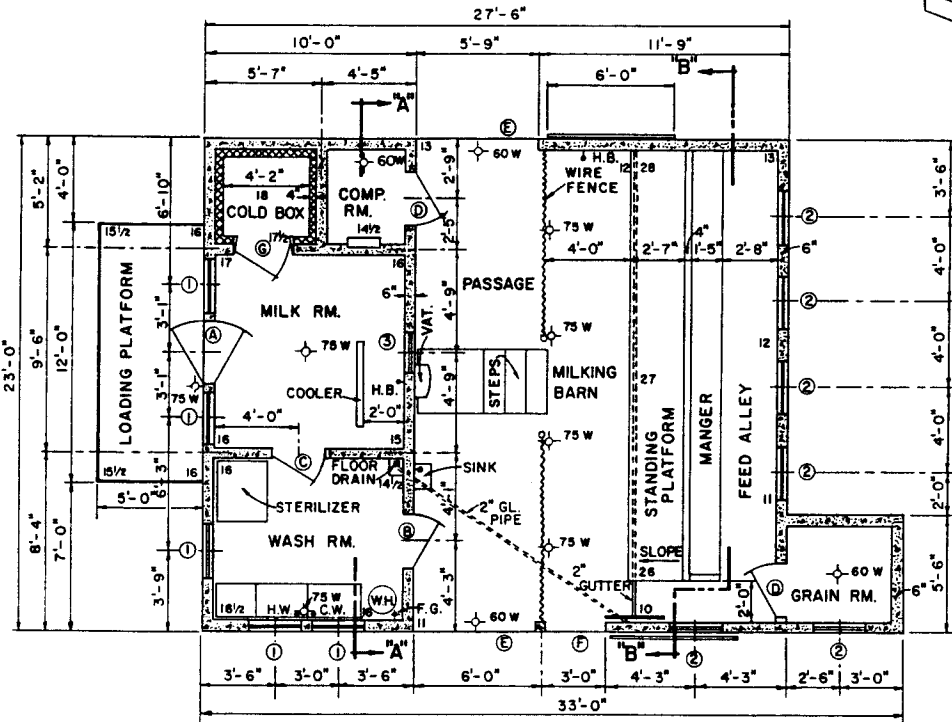

FLOOR PLAN

NOTE: CONSULT YOUR LOCAL HEALTH AND BUILDING CODE AUTHORITIES BEFORE STARTING CONSTRUCTION. CAPACITY: 10 GOATS

MILKHOUSE MUST BE AT LEAST 100 FEET FROM FEEDING BARN OR RACKS.

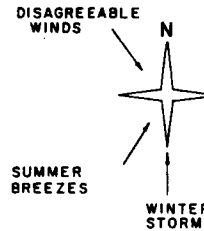

PLOT PLAN FOR WIND DIRECTIONS AS SHOWN

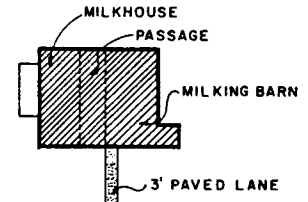

NOTE: THE MILKHOUSE SHALL BE LOCATED TO THE WINDWARD OF THE MILKING BARN, CORRALS, FEED SHEDS, ETC. CONSULT YOUR LOCAL INSPECTOR.

ELECTRICAL SYMBOLS

	CEILING OUTLETS, WATTS NOTED
	BRACKET OUTLETS, WATTS NOTED
	CUTOUT CABINET & MAIN SERVICE SWITCH
NOTE: ALL LIGHTS TO BE CONTROLLED FROM PANEL BOARD	

GENERAL SYMBOLS

H.B. •	HOSE BIBBS, COLD WATER
H.W. •	HOT WATER
C.W. •	COLD WATER
F.G. •	FUEL GAS

DOOR SCHEDULE

MARK	SIZE	TYPE	NO. REQ'D
(A)	3'-0" x 7'-0" x 1 1/4"	GLASS & PANEL - SCREENED	1
(B)	2'-6" x 6'-8" x 1 1/4"	SCREEN & PANEL	1
(C)	2'-6" x 6'-8" x 1 1/4"	SCREEN OR SCREEN & PANEL	1
(D)	2'-6" x 6'-8" x 1 1/4"	PANEL	2
(E)	6'-0" x 6'-8" x 1 1/4"	RUSTIC PANELS - ROLLING	2
(F)	2'-9" x 6'-8" x 1 1/4"	RUSTIC PANELS - ROLLING	1
(G)	2'-9" x 6'-8" x 1 1/4"	SPECIAL - REFRIGERATOR	1

WINDOW SCHEDULE

MARK	SIZE	TYPE	NO. REQ'D
(1)	2'-6" x 3'-0" x 1 1/4"	SASH, DROP-IN SCREENED	5
(2)	2'-6" x 3'-0" x 1 1/4"	SASH, DROP-IN	6
(3)	2'-0" x 2'-0"	SPECIAL	1
NOTE: ALL 2'-6" x 3'-0" SASH TO BE 4 LIGHT.			

COOPERATIVE EXTENSION WORK IN AGRICULTURE AND HOME ECONOMICS

THE PENNSYLVANIA STATE UNIVERSITY  
AND  
UNITED STATES DEPARTMENT OF AGRICULTURE COOPERATING  
MILKING BARN & MILKHOUSE  
FOR 10 GOATS

CALIF. '77 6255 SHEET 1 OF 2

BASED ON: UNIV. OF CALIF. PLAN C-230-3-1,2,8,3.

METAL ROOF:  
 2x6 RAFTERS  
 2x6 TIES  
 2x6 PURLINS CUT BETWEEN

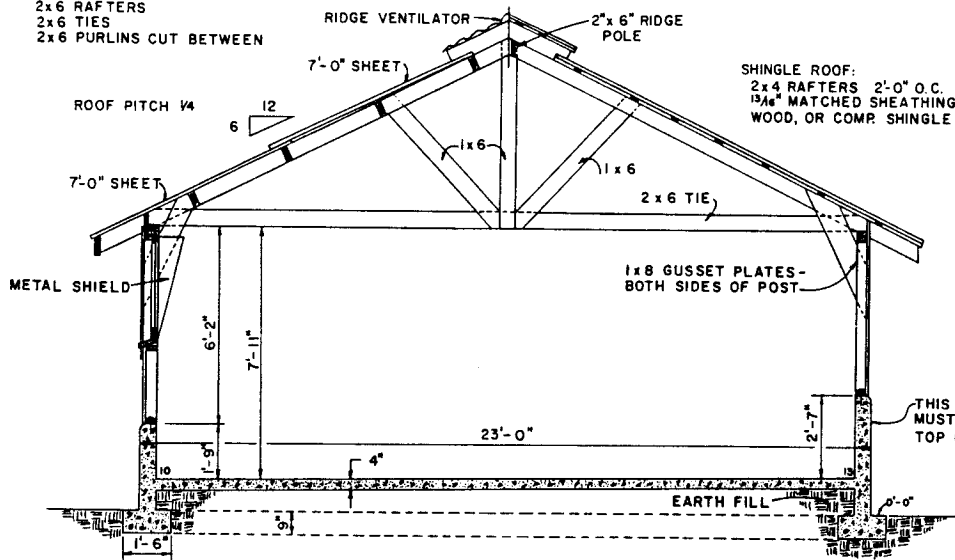

SECTION B-B

NOTE: CARRY FOOTINGS BELOW FROST LINE TO REST ON UNDISTURBED EARTH.

NOTE:  
 CONCRETE WALL MAY BE RAISED A FEW INCHES SO AS TO ELIMINATE THE STUDS UNDER THE WINDOWS. WHEN THIS STYLE MANGER IS USED, TOTAL LENGTH OF BARN IS DECREASED FROM 27'-6" TO 25'-1".

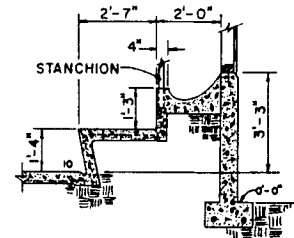

ALTERNATE MANGER

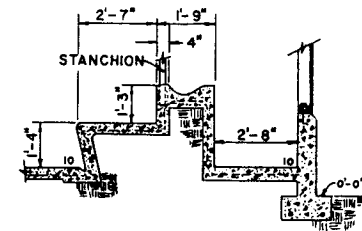

MANGER

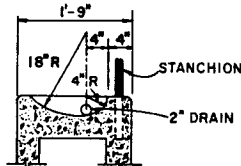

MANGER DETAIL

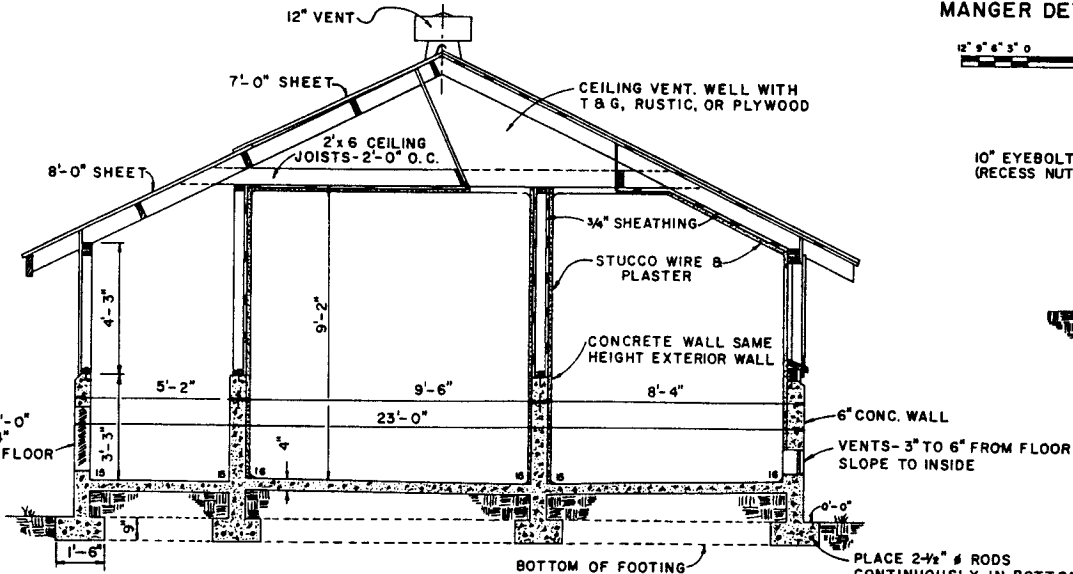
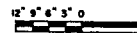

SECTION A-A

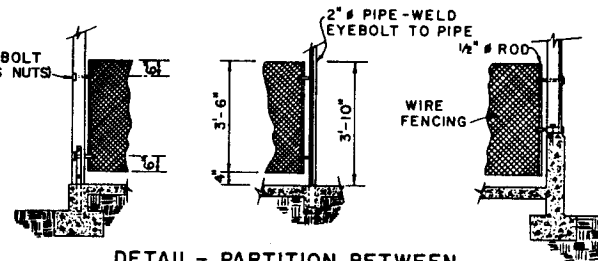

DETAIL - PARTITION BETWEEN MILKING BARN & PASSAGE

COOPERATIVE EXTENSION WORK IN AGRICULTURE AND HOME ECONOMICS		
THE PENNSYLVANIA STATE UNIVERSITY		
AND UNITED STATES DEPARTMENT OF AGRICULTURE COOPERATING		
MILKING BARN & MILKHOUSE FOR 10 GOATS		
CALIF. '77	6255	SHEET 2 OF 2

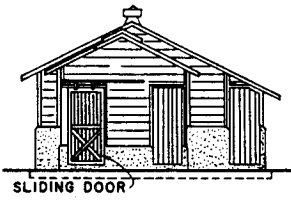

EAST VIEW

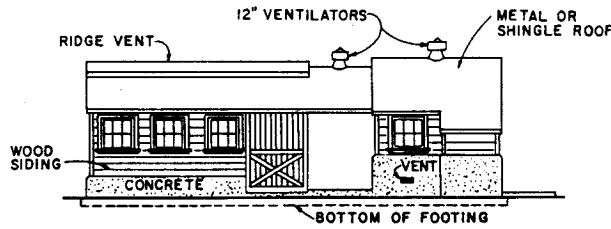

NORTH VIEW

ELEVATIONS

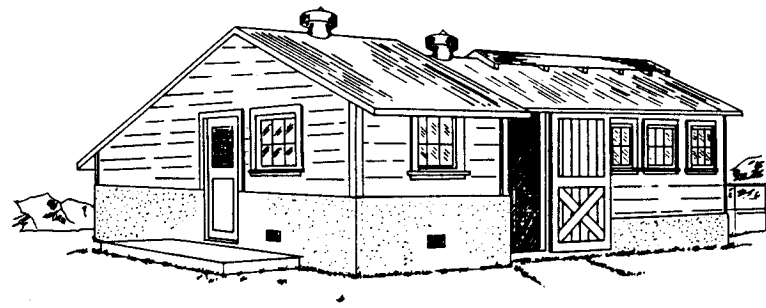

PERSPECTIVE

NO SCALE

MILKHOUSE MUST BE AT LEAST 100 FT. FROM FEEDING BARN OR RACKS

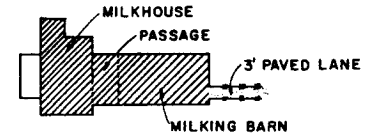

NOTE: THE MILKHOUSE SHALL BE LOCATED TO THE WINDWARD OF THE MILKING BARN, CORRALS, FEED SHEDS, ETC. CONSULT YOUR LOCAL INSPECTOR.

PLOT PLAN FOR WIND DIRECTIONS AS SHOWN

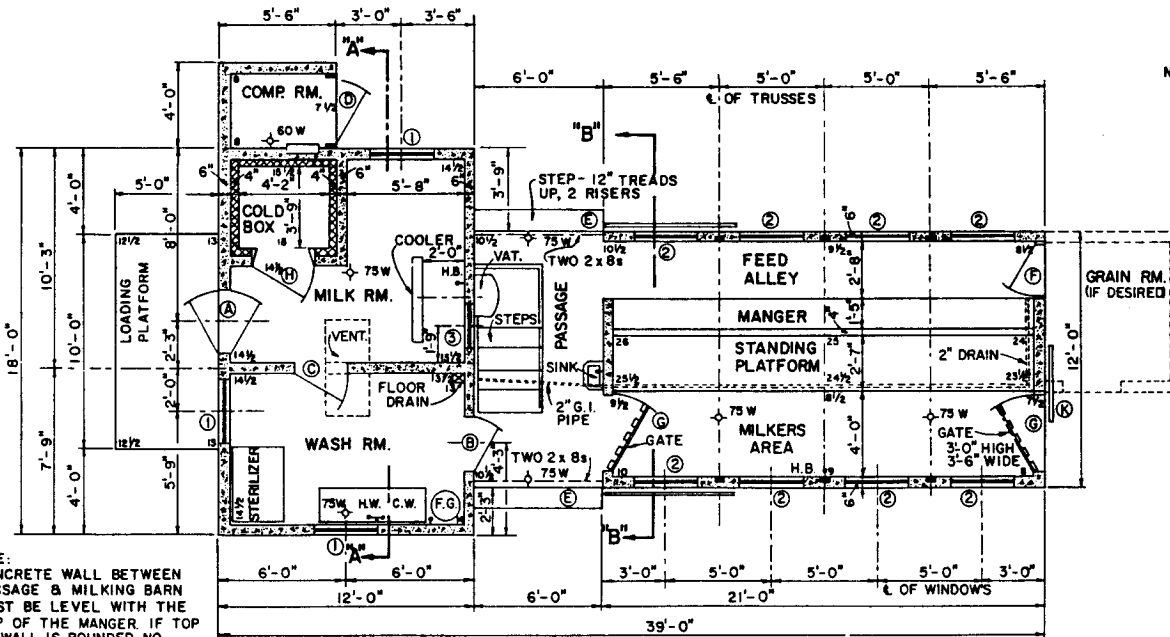
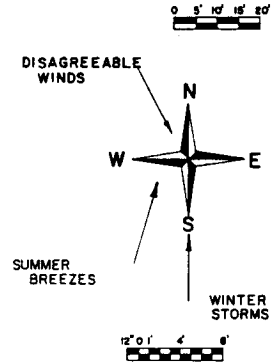

NOTE: CONCRETE WALL BETWEEN PASSAGE & MILKING BARN MUST BE LEVEL WITH THE TOP OF THE MANGER IF TOP OF WALL IS ROUNDED, NO FURTHER FRAMING OR WALL IS REQUIRED.

FLOOR PLAN

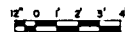

BASED ON: UNIV. OF CALIF. PLAN C-231-3

COOPERATIVE EXTENSION WORK IN AGRICULTURE AND HOME ECONOMICS		
THE PENNSYLVANIA STATE UNIVERSITY		
AND UNITED STATES DEPARTMENT OF AGRICULTURE COOPERATING		
MILKING BARN & MILKHOUSE FOR 10 GOATS		
CALIF. '77	6256	SHEET 1 OF 2

METAL ROOF:  
2 x 6 RAFTERS 2'-0" O.C.  
2 x 6 PURLINS CUT BETWEEN

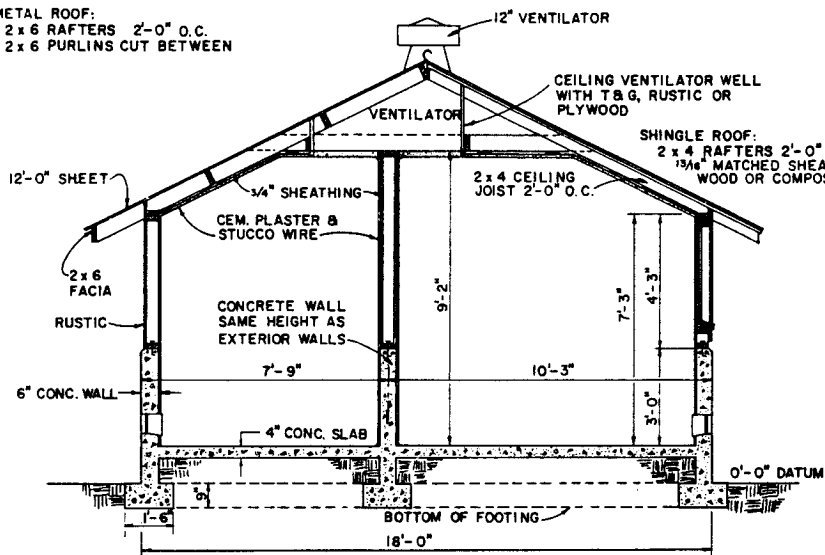

SECTION "A-A"

METAL ROOF:  
2 x 4 RAFTERS 5'-0" O.C.  
2 x 4 PURLINS CUT BETWEEN RAFTERS

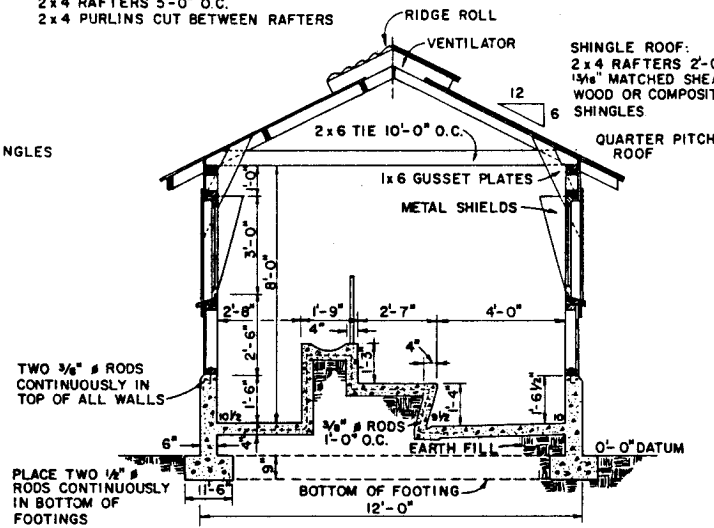

SECTION "B-B"

NOTE:  
IF PIPELINE SYSTEM IS USED, MILKERS AREA MAY BE REDUCED FROM 6'-5" TO 4'-5" AND TOTAL WIDTH OF BARN REDUCED TO 10'-0". THE 12'-0" WIDTH IS NEEDED TO OBTAIN HEAD CLEARANCE OVER POURING PLATFORM.

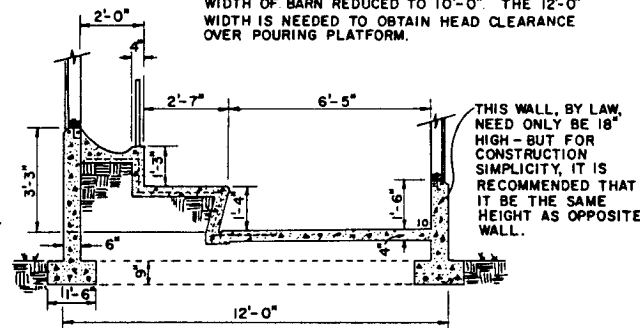

ALTERNATE SECTION "B-B"

THIS CONCRETE WALL MAY BE RAISED A FEW INCHES SO AS TO ELIMINATE THE STUDS UNDER THE WINDOWS.

NOTE:  
FRAMING ABOVE TO BE SAME AS SECTION "B-B"

GENERAL SYMBOLS

H.B.	HOSE BIBBS, COLD WATER
H.W.	HOT WATER
C.W.	COLD WATER
F.G.	FUEL GAS

ELECTRICAL SYMBOLS

MARK	DESCRIPTION
⊙	CEILING OUTLET, WATTS NOTED
⊙	BRACKET OUTLETS, WATTS NOTED
⊙	CUTOUT CABINET & MAIN SERVICE SWITCH
ALL LIGHTS TO BE CONTROLLED FROM PANEL BOARD	

DOOR SCHEDULE

MARK	SIZE	TYPE	NO. REQ'D.
Ⓐ	3'-0" x 7'-0" x 1 1/2"	GLASS & PANEL - SCREENED	1
Ⓑ	2'-6" x 6'-8" x 1 1/4"	SCREEN & PANEL	1
Ⓒ	2'-6" x 6'-8" x 1 1/4"	SCREEN & PANEL OR SCREEN	1
Ⓓ	3'-0" x 6'-6" x 1 3/4"	RUSTIC PANEL	1
Ⓔ	6'-0" x 7'-2" x 1 3/4"	RUSTIC PANEL - SLIDING	2
Ⓕ	2'-6" x 6'-8" x 1 3/4"	RUSTIC PANEL	1
Ⓖ	3'-0" x 3'-6" x 1 3/4"	GATE	2
Ⓗ	SPECIAL	REFRIGERATOR	1
Ⓘ	3'-8" x 7'-2" x 1 3/4"	RUSTIC PANEL - SLIDING	1

WINDOW SCHEDULE

MARK	SIZE	TYPE	NO. REQ'D.
Ⓐ	3'-0" x 3'-0" x 1 1/2"	DROP-IN SASH - SCREENED	3
Ⓑ	3'-0" x 3'-0" x 1 1/2"	DROP-IN SASH	8
Ⓒ	SPECIAL		1
ALL 3'-0" x 3'-0" SASH TO BE 6 LIGHT			

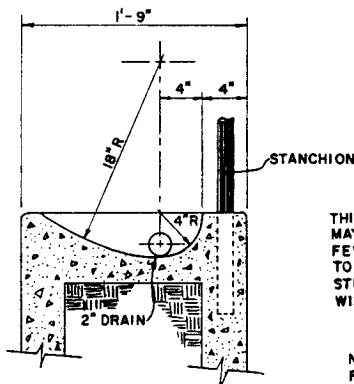

MANGER DETAIL



COOPERATIVE EXTENSION WORK IN  
AGRICULTURE AND HOME ECONOMICS

THE PENNSYLVANIA STATE UNIVERSITY  
AND  
UNITED STATES DEPARTMENT OF AGRICULTURE COOPERATING

MILKING BARN & MILKHOUSE  
FOR 10 GOATS

CALIF. '77	6256	SHEET 2 OF 2
------------	------	--------------

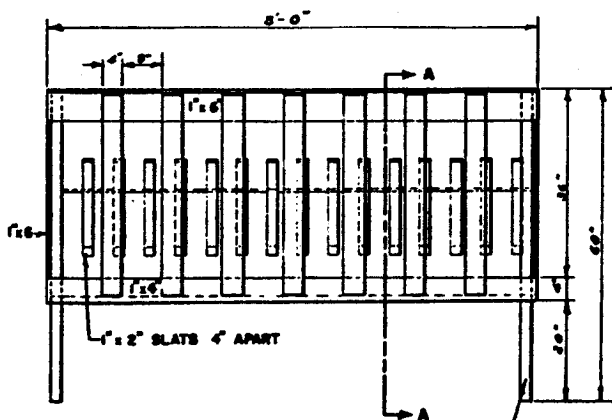

SIDE VIEW  
DOUBLE FEEDER

DIP LEGS IN WOOD PRESERVATIVE TO PREVENT DECAY.

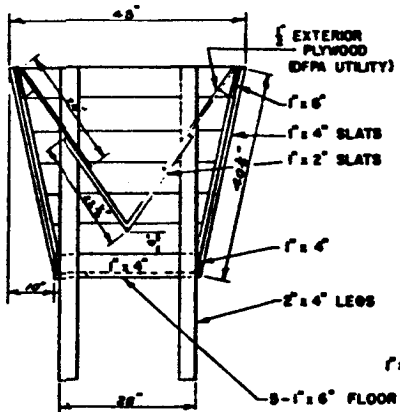

SECTION A-A

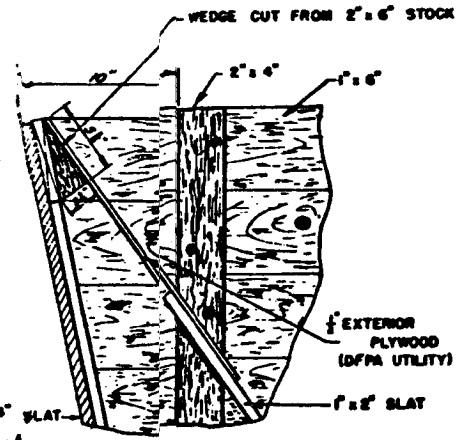

ENLARGED VIEW OF CORNER DETAIL

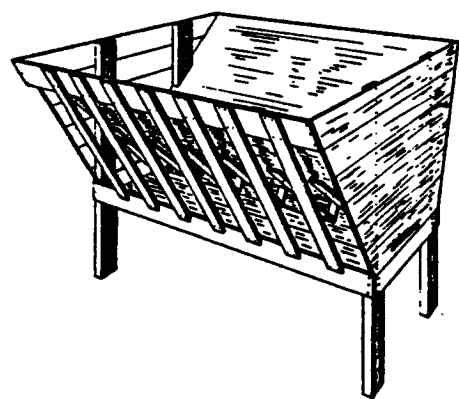

PERSPECTIVE VIEW  
OF  
DOUBLE FEEDER

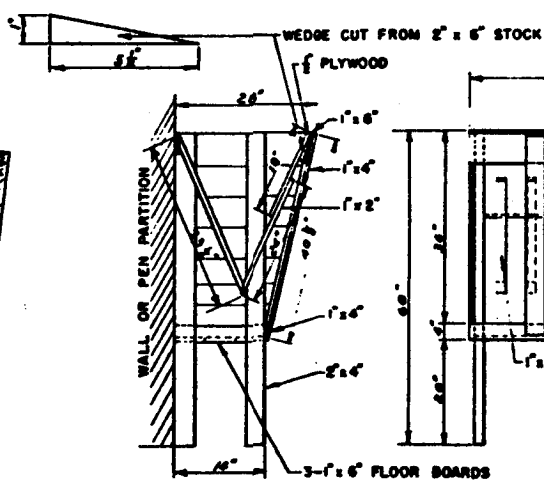

SECTION B-B

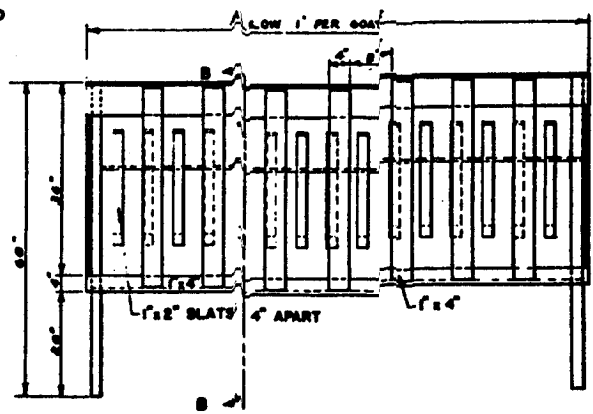

SIDE VIEW  
SINGLE FEEDER

TO BE USED WITH:  
DAIRY GOAT CORRESPONDENCE COURSE 105  
LESSON NO. 5

THE PENNSYLVANIA STATE UNIVERSITY	
AGRICULTURAL EXTENSION SERVICE	
FEED RACKS FOR GOATS	
ORDER NO. 728-99	SHEET 1 OF 1

27/2/53



**Idea Plan  
Sheep Housing, Fencing, Feeders, and Equipment**

**No. IP 725-24**

This Idea Plan is intended to provide educational information and ideas concerning housing; fence and creep panels; hay, grain, and mineral feeders; and a tilting squeeze for use with sheep. The following attached drawings are based on historical plans and may not meet design and construction standards for your area:

- Pen Panel and Portable Fence for Sheep ( PSU 86)
- Fencing and Creep Panels for Sheep (PSU 60)
- Hay & Grain Feeder for 12 Sheep or Goats (PSU 80)
- Hay Feed Rack for Sheep (PSU 82)
- Mineral Feeder for Sheep (USDA 5916)
- Creep and Grain Trough for Lambs (PSU 87)
- Tilting Squeeze for Sheep (USDA 6006)
- Sheep and Lambing Shed (USDA 5919)
- Portable Shelter (PSU 01)

If you decide to build a facility similar to any of these plans, be sure to check building requirements for your area. Your local building inspector, engineer, building supplier, or building contractor can help you determine what is a safe and legal facility for housing sheep in your area. In addition to the rules and regulations covering design and construction of buildings, be sure to consider how you will handle the manure and potential nuisance problems for neighbors, including flies, odor, and noise.

The Department of Agricultural and Biological Engineering at Penn State has a variety of educational material available related to agricultural and biological engineering. This material is intended to help Pennsylvania farmers and others develop buildings and facilities for modern, environmentally-compatible farm facilities. The material can be used in conjunction with county extension staff, builders, suppliers, consulting engineers, the Natural Resources Conservation Service, financial management advisors, farm lenders, veterinarians, and others to assemble a facilities plan suitable for local conditions.

Publications are available in the areas of agricultural safety and health, animal housing systems, building and farmstead planning, crops and greenhouses, machinery systems and tractors, residential housing, soil and water resources, and solid waste management. Contact your county Penn State Extension Office for more information on these subjects. You can also obtain an index of publications concerning the above areas by calling, writing, faxing or e-mailing:

Department of Agricultural and Biological Engineering  
 246 Agricultural Engineering Building  
 University Park, PA, 16802-1909  
 Telephone: 814-865-7685    Fax: 814-863-1031    E-mail: [agbioeng@psu.edu](mailto:agbioeng@psu.edu).

For more complete information, the following comprehensive handbook covering the many aspects of sheep housing and equipment is available:

MWPS-03—Sheep Housing and Equipment Handbook (1994).  
 \$10.00 (Contact office below for current pricing).

Order from your local county Penn State Cooperative Extension Office or the Publications Distribution Center, The Pennsylvania State University, 112 Agricultural Administration Building, University Park, PA 16802-2602 (Telephone: 814-865-6713 or Fax: 814-863-5560).



---

This publication is available in alternative media on request.

The Pennsylvania State University is committed to the policy that all persons shall have equal access to programs, facilities, admission, and employment without regard to personal characteristics not related to ability, performance, or qualifications as determined by University policy or by state or federal authorities. The Pennsylvania State University does not discriminate against any person because of age, ancestry, color, disability or handicap, national origin, race, religious creed, sex, sexual orientation, or veteran status. Direct all inquiries regarding the nondiscrimination policy to the Affirmative Action Director, The Pennsylvania State University, 201 Willard Building, University Park, PA 16802-2801; tel. (814) 863-0471; TDD (814) 865-3175.

ALL PARTS 1" x 4" EXCEPT  
AS NOTED

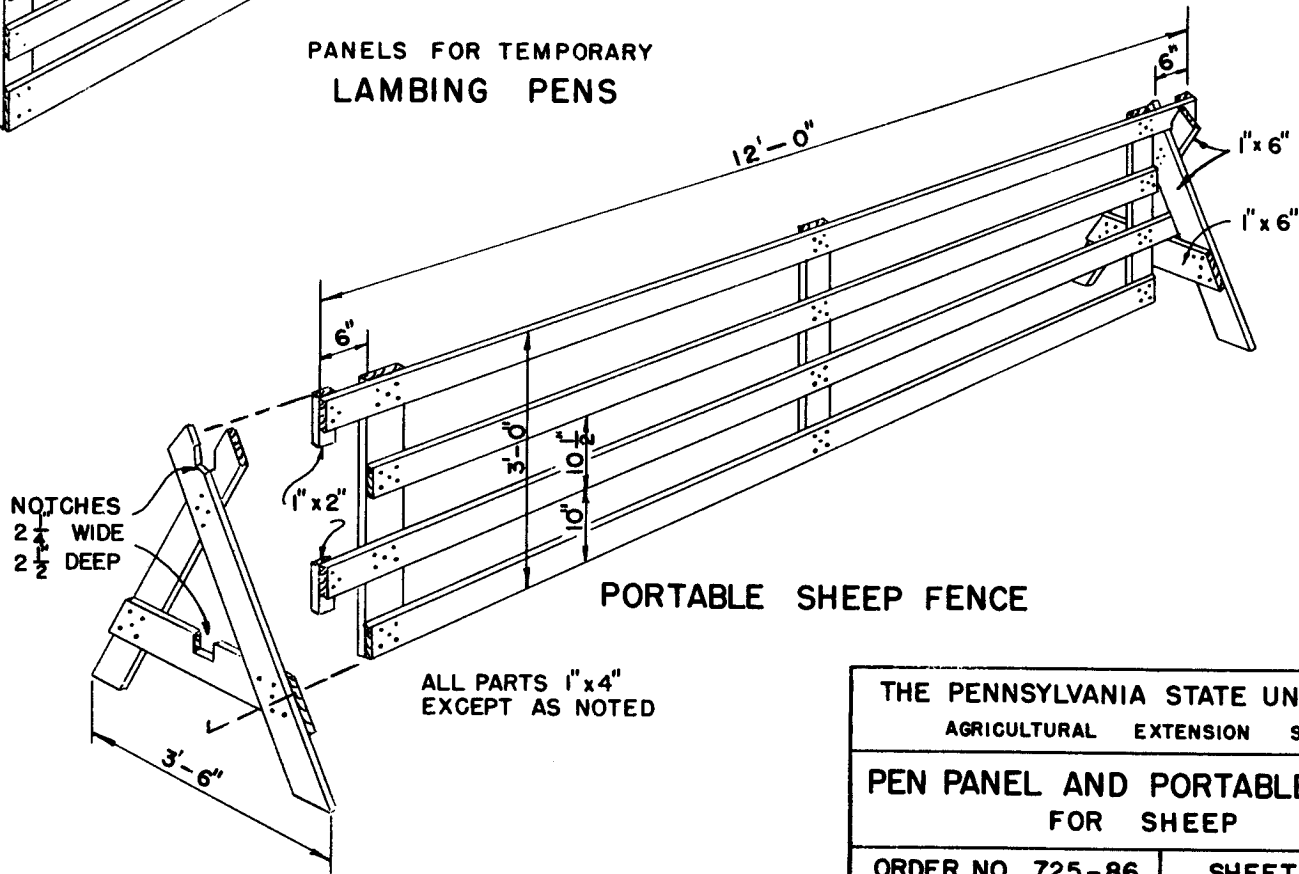
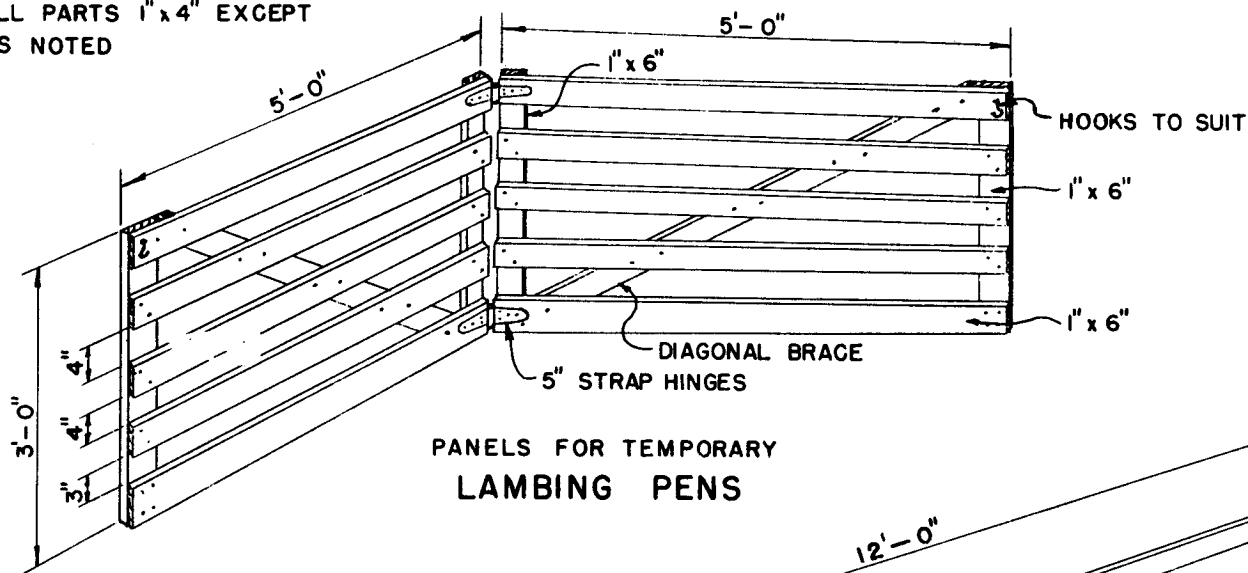

THE PENNSYLVANIA STATE UNIVERSITY  
AGRICULTURAL EXTENSION SERVICE

PEN PANEL AND PORTABLE FENCE  
FOR SHEEP

ORDER NO. 725-86

SHEET 1 OF 1

ADAPTED FROM U.S.D.A. PLAN NO. 5802

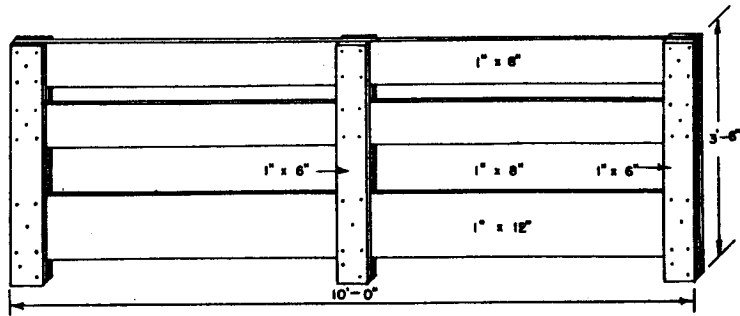

PANEL FOR EWES

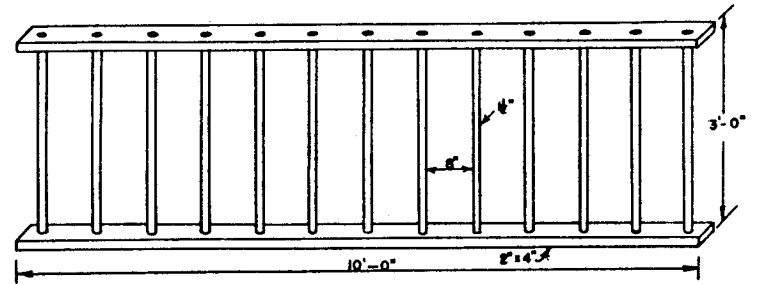

CREEP PANEL

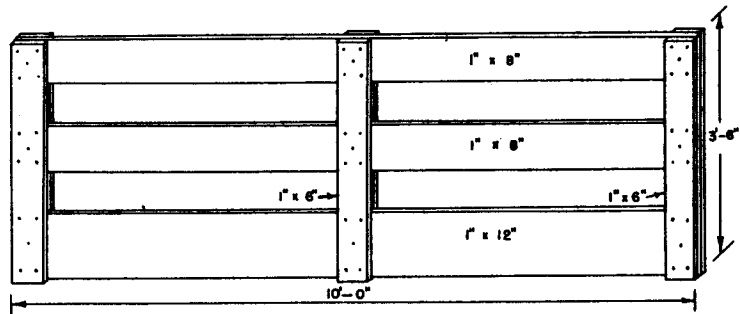

PANEL FOR LAMBS

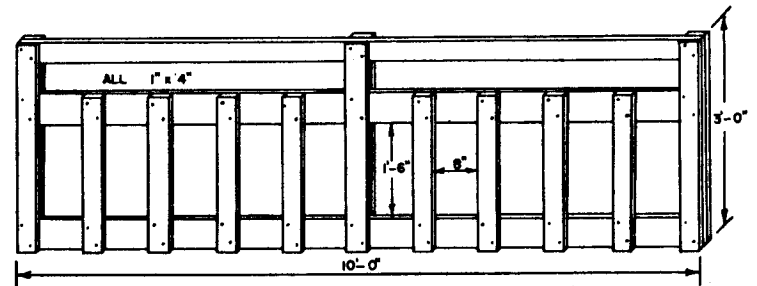

PANEL FOR CREEP FEEDING

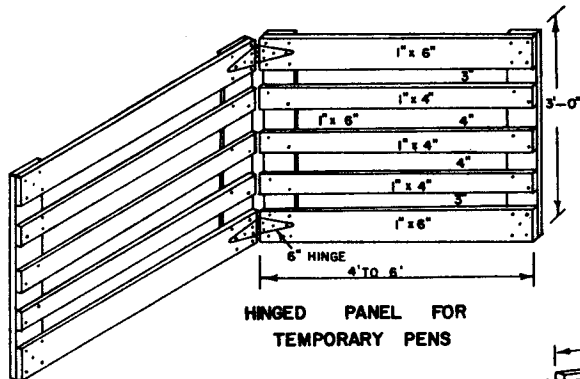

HINGED PANEL FOR TEMPORARY PENS

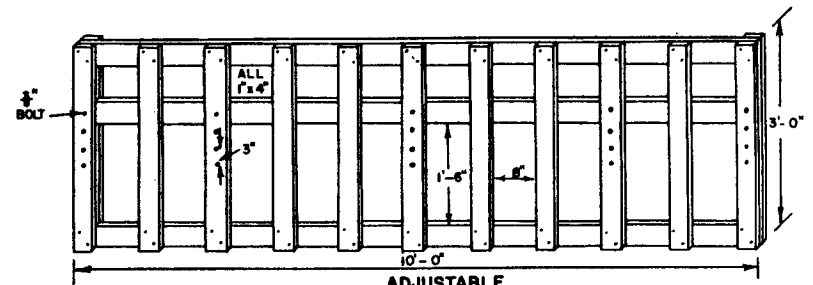

ADJUSTABLE PANEL FOR CREEP FEEDING

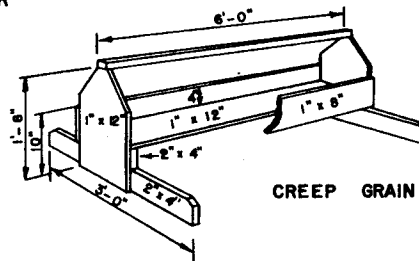

CREEP GRAIN TROUGH

THE PENNSYLVANIA STATE UNIVERSITY  
AGRICULTURAL EXTENSION SERVICE

FENCING AND CREEP PANELS  
FOR SHEEP

DRN BY: ARG  
TRD BY: AKG  
DATE: 5-74

ORDER NO.  
725-60

SHEET  
1 OF 1

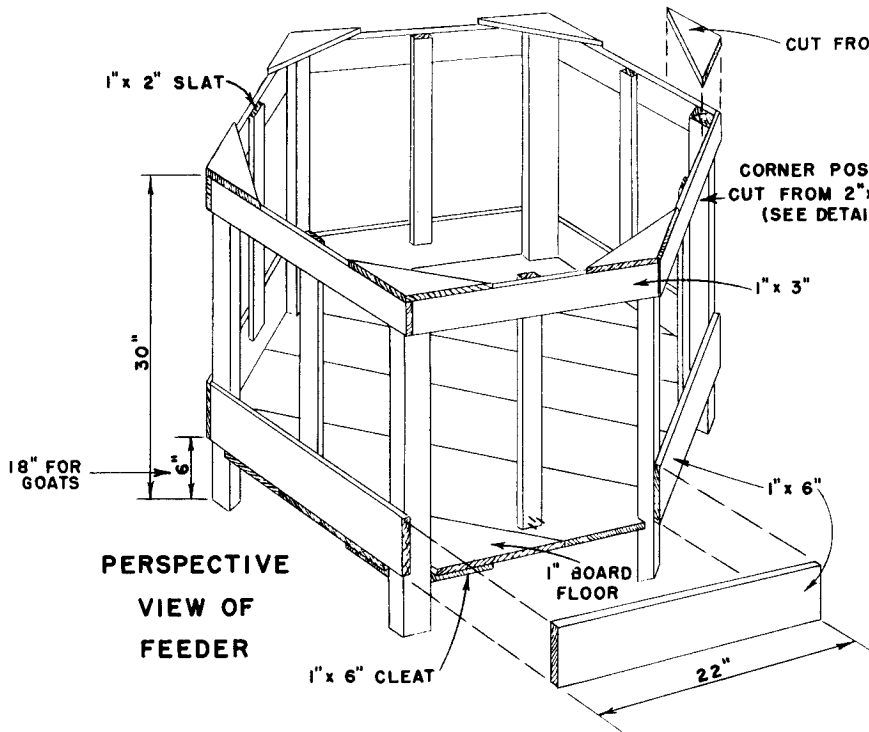

**NOTE:** (DOES) FOR SMALL EWES AND LAMBS, (KIDS) USE 1" x 6" VERTICAL SLATS INSTEAD OF 1" x 2" AS SHOWN.

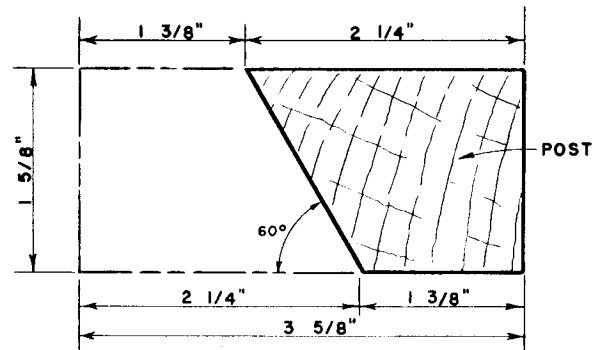
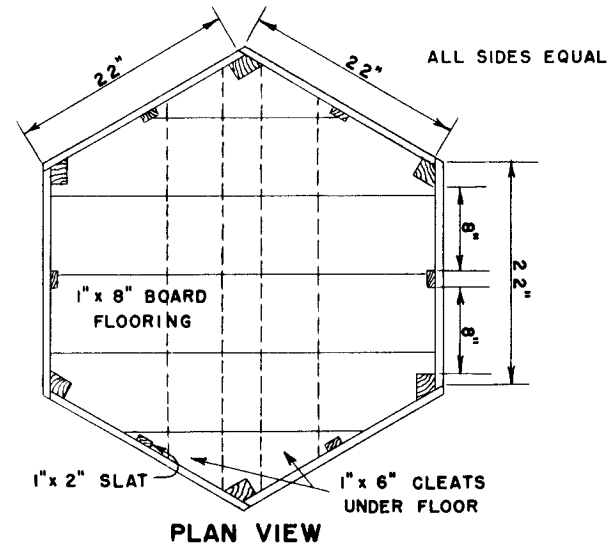

**CORNER POST DETAIL**  
CUT TWO FROM DRESSED 2" x 4"

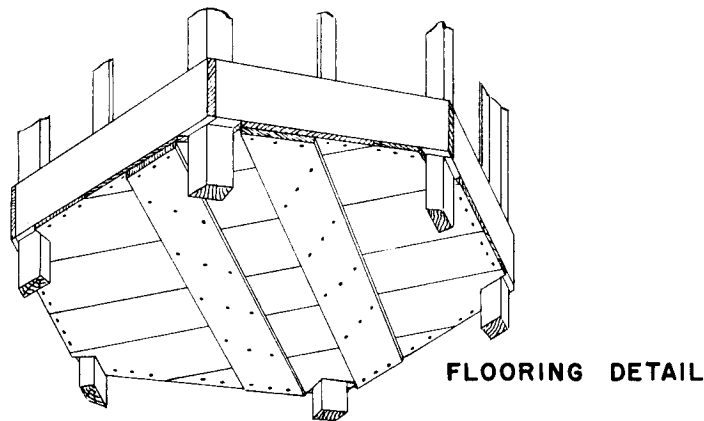

THE PENNSYLVANIA STATE UNIVERSITY AGRICULTURAL EXTENSION SERVICE	
HAY & GRAIN FEEDER FOR 12 SHEEP OR GOATS ADAPTED FROM U.S.D.A. PLAN EX. 5807	
ORDER NO. 725 - 80	SHEET 1 OF 1

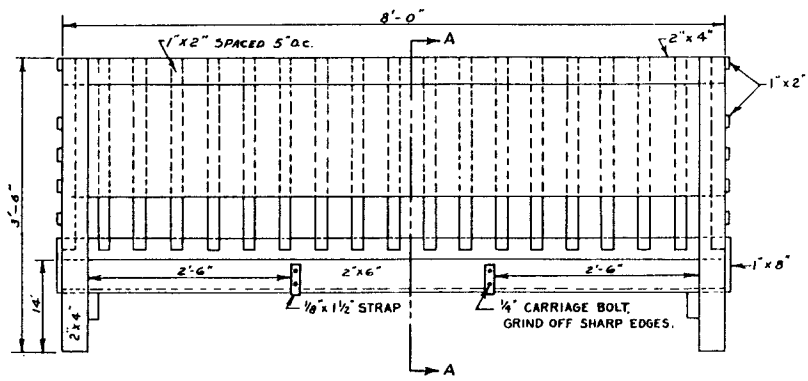

SIDE ELEVATION

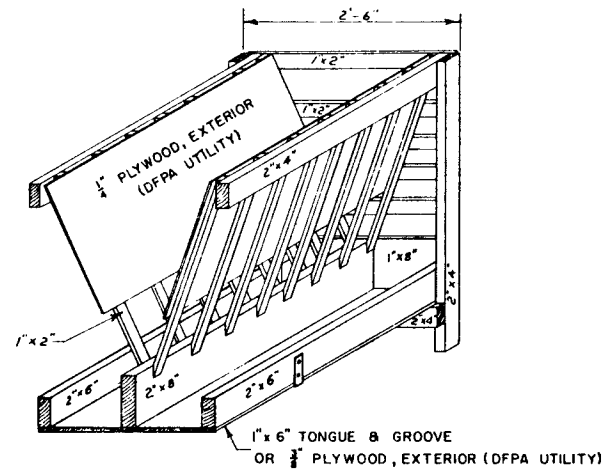

ISOMETRIC VIEW  
THRU SECTION A-A

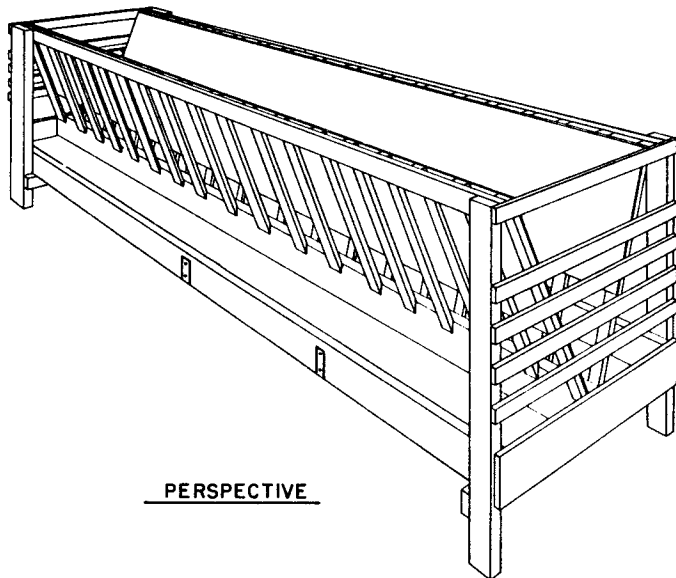

PERSPECTIVE

THE PENNSYLVANIA STATE UNIVERSITY  
AGRICULTURAL EXTENSION SERVICE

**HAY FEED RACK FOR SHEEP**

ORDER NO. 725 - 82

SHEET 1 OF 1

REVISED FEB., 1960

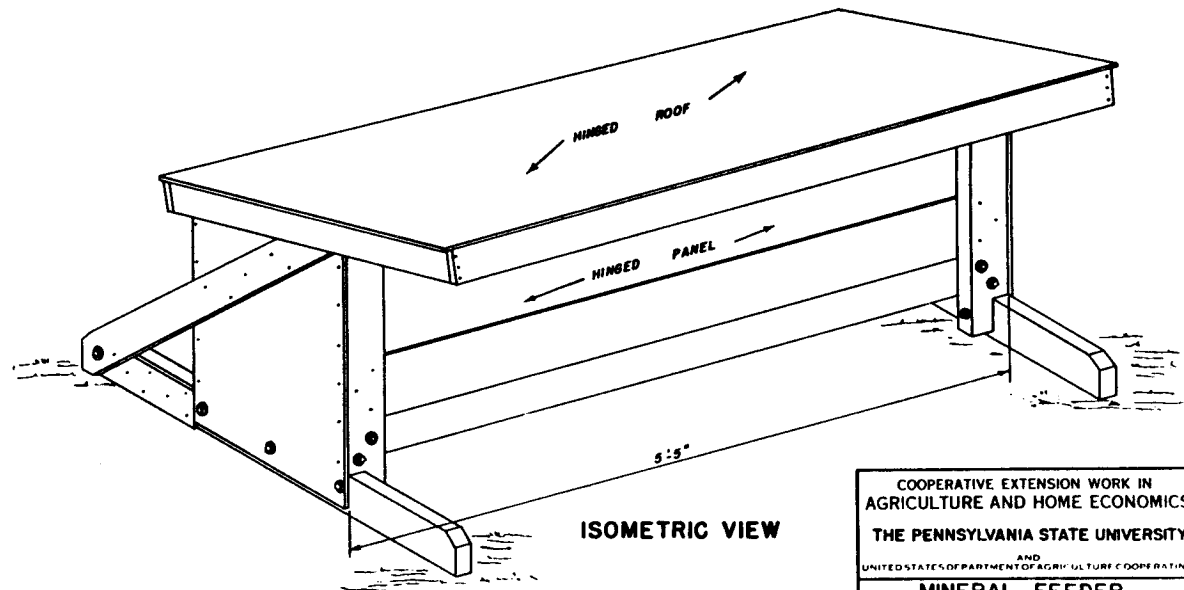
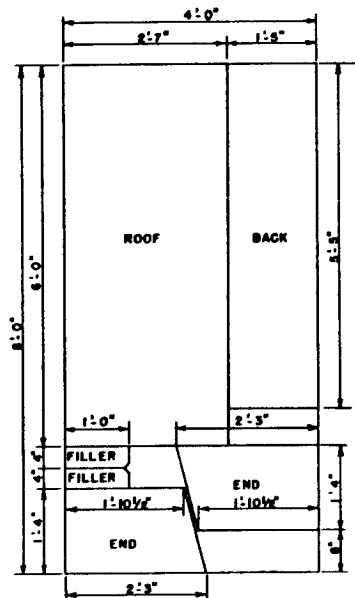
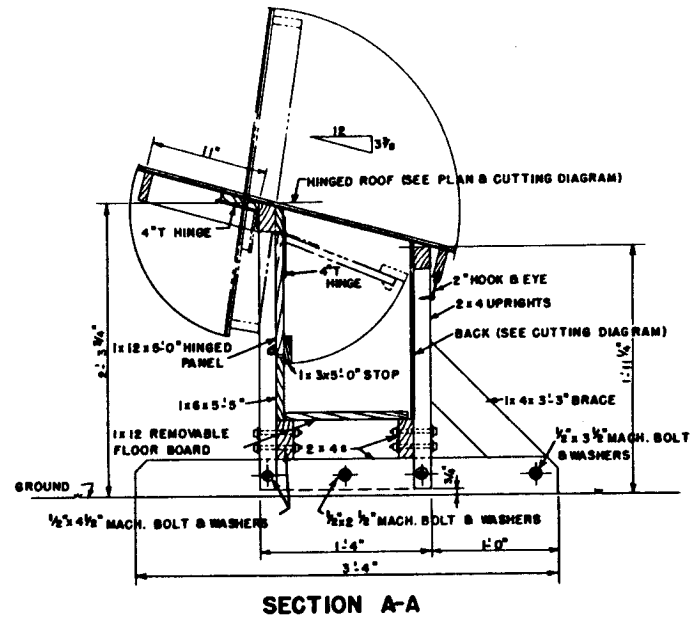
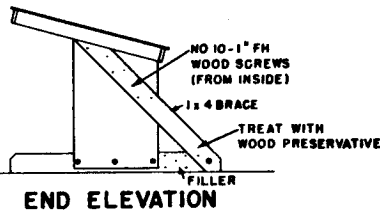
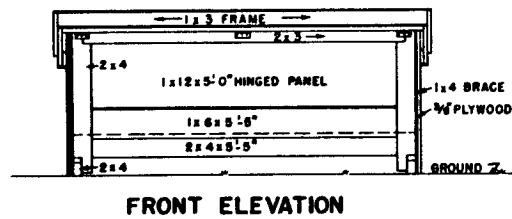
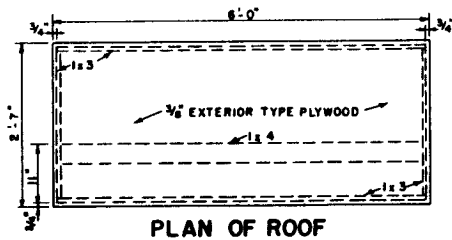

COOPERATIVE EXTENSION WORK IN AGRICULTURE AND HOME ECONOMICS		
THE PENNSYLVANIA STATE UNIVERSITY		
AND UNITED STATES DEPARTMENT OF AGRICULTURE COOPERATING		
<b>MINERAL FEEDER</b>		
FOR SHEEP		
USDA '60	EX 5916	SHEET 1 OF 1
ORDER NO. 725-5916		

NOTE:

ALL PARTS 1"x6"  
EXCEPT AS NOTED

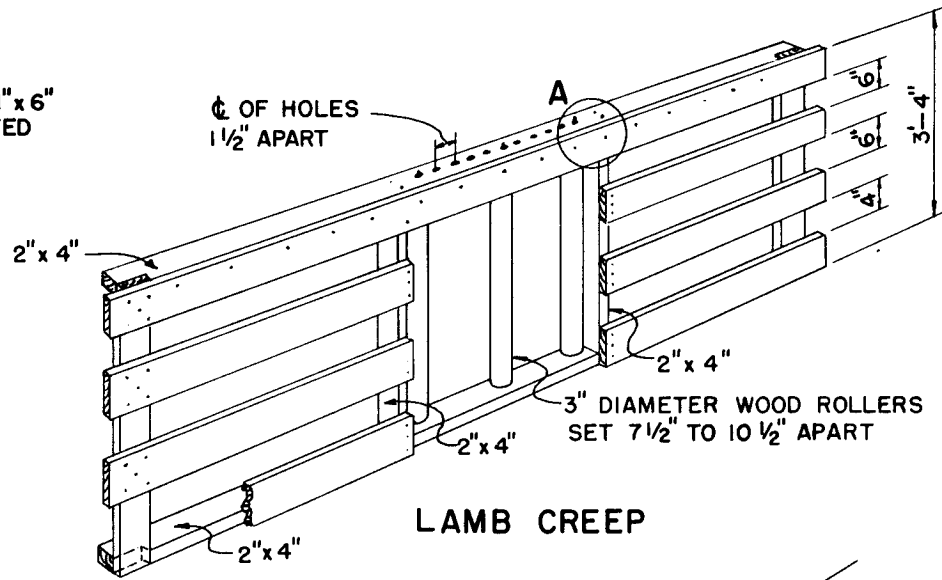

LAMB CREEP

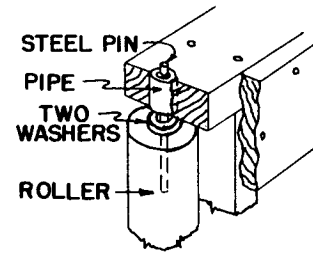

DETAIL A

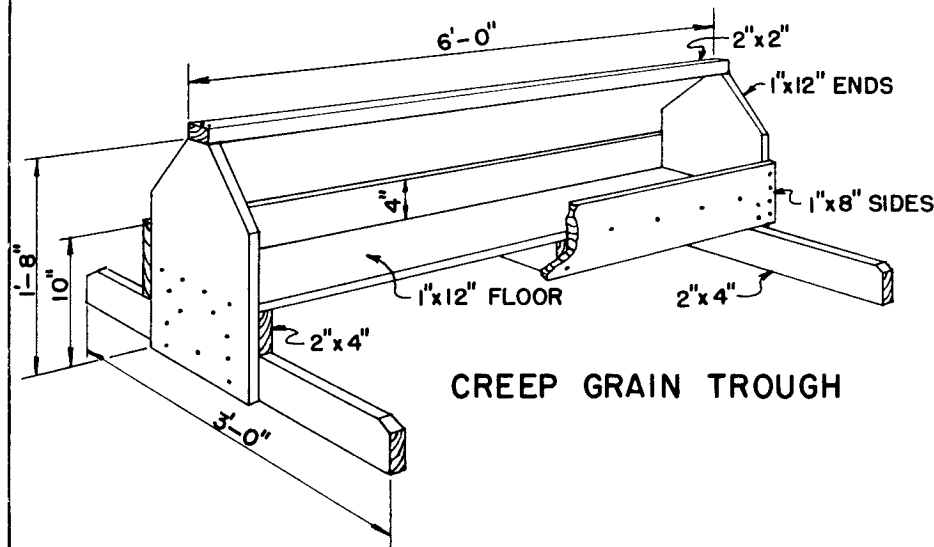

CREEP GRAIN TROUGH

THE PENNSYLVANIA STATE UNIVERSITY  
AGRICULTURAL EXTENSION SERVICE

CREEP AND GRAIN TROUGH  
FOR LAMBS

ORDER NO. 725-87

SHEET 1 OF 1

ADAPTED FROM U.S.D.A. PLAN NO. 5802

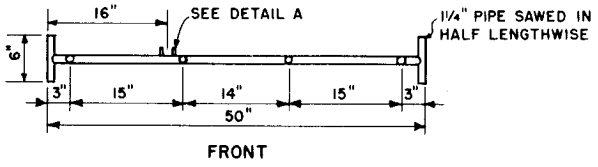
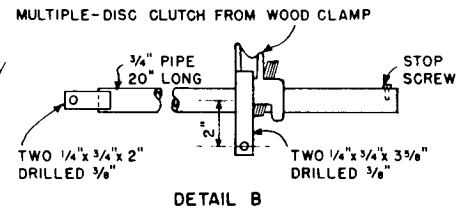
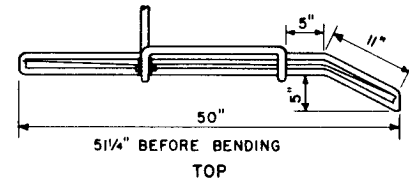
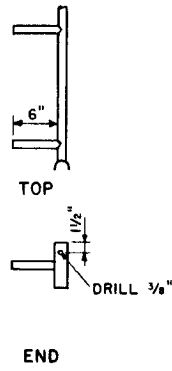
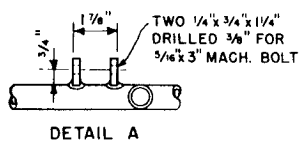

**TOP PANEL FRAME**  
ALL 3/4" PIPE EXCEPT AS NOTED

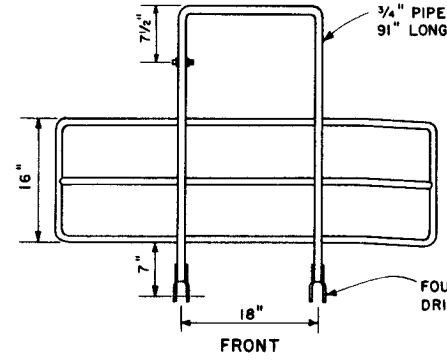

**SQUEEZE PANEL**  
ALL 1/2" PIPE EXCEPT AS NOTED

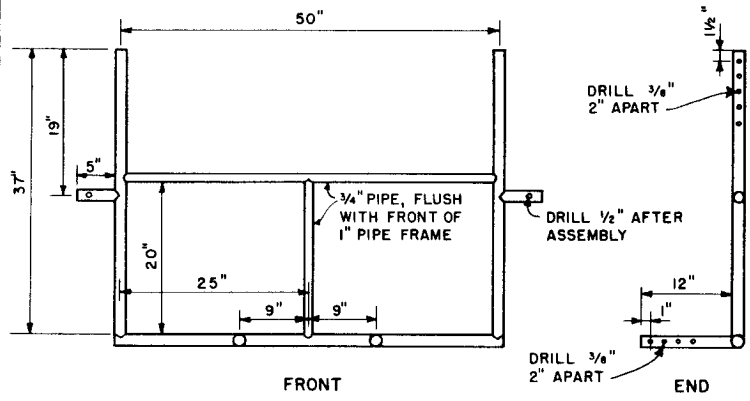

**BACK PANEL FRAME**  
ALL 1" PIPE EXCEPT AS NOTED

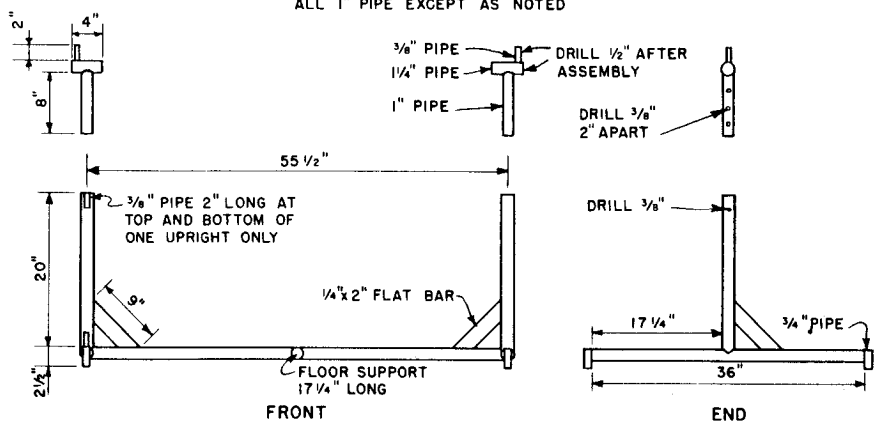

**BASE FRAME**  
ALL 1 1/4" PIPE EXCEPT AS NOTED

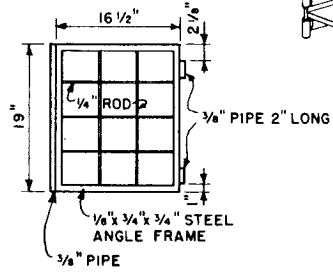
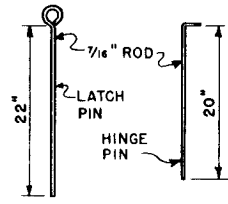

**CHUTE GATE**

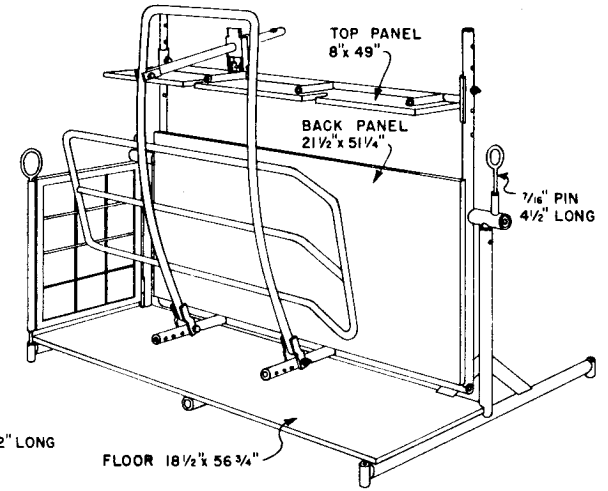

**PERSPECTIVE**

NOTE: ALL PIPES ARE STANDARD SIZE  
ALL JOINTS ARE WELDED

PANELS AND FLOOR ARE 1/2" EXTERIOR PLYWOOD,  
FASTENED WITH 1/4" CARRIAGE BOLTS  
USE 3/8" MACHINE BOLTS IN 3/8" HOLES

COOPERATIVE EXTENSION WORK IN  
AGRICULTURE AND HOME ECONOMICS

THE PENNSYLVANIA STATE UNIVERSITY

AND  
UNITED STATES DEPARTMENT OF AGRICULTURE COOPERATING

**TILTING SQUEEZE FOR SHEEP**

ORE.	'67	EX. 6006	SHEET 1 OF 1
ORDER NO. 725-6006			



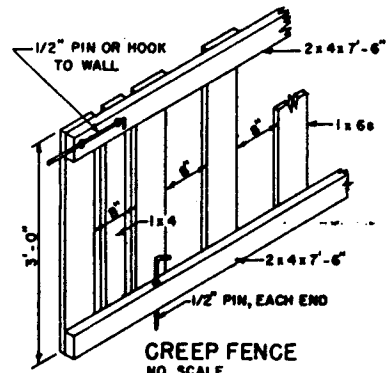
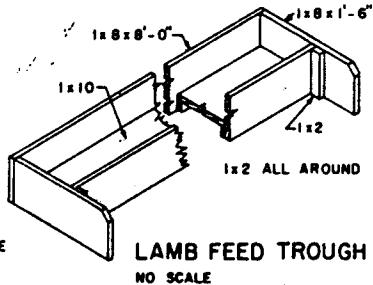
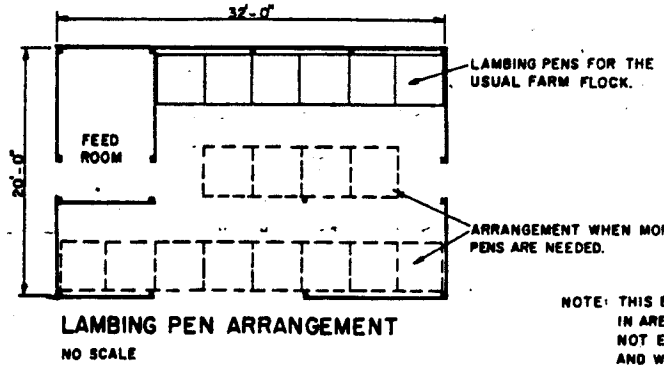
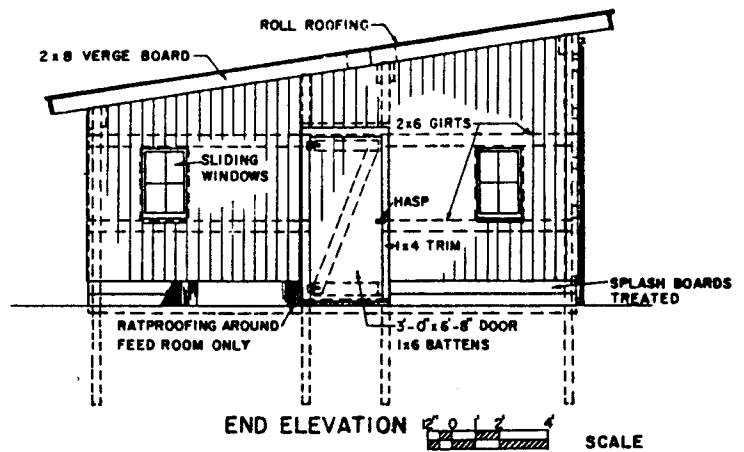
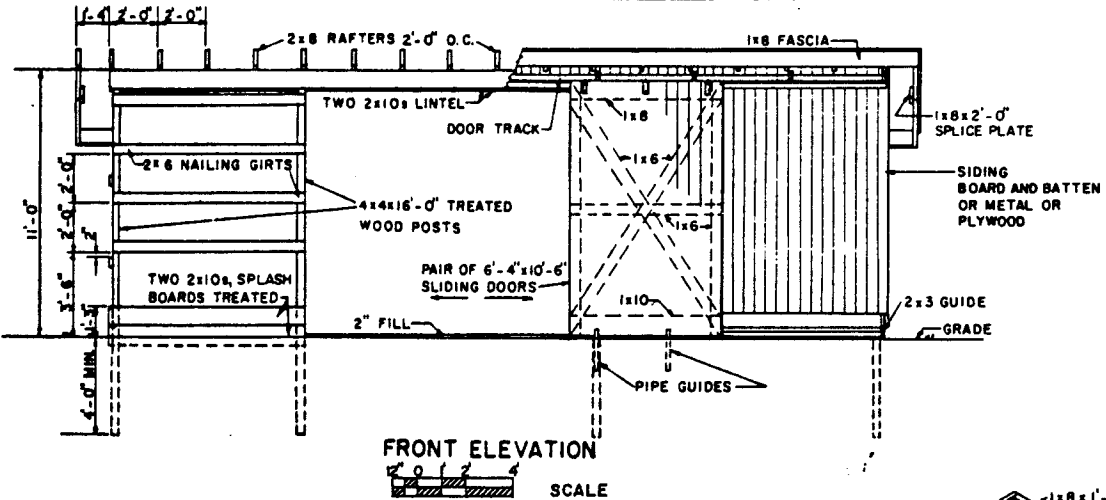
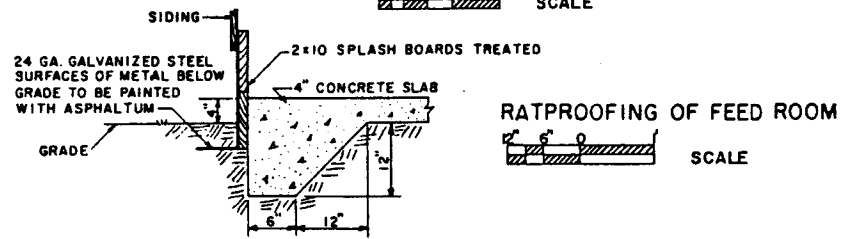
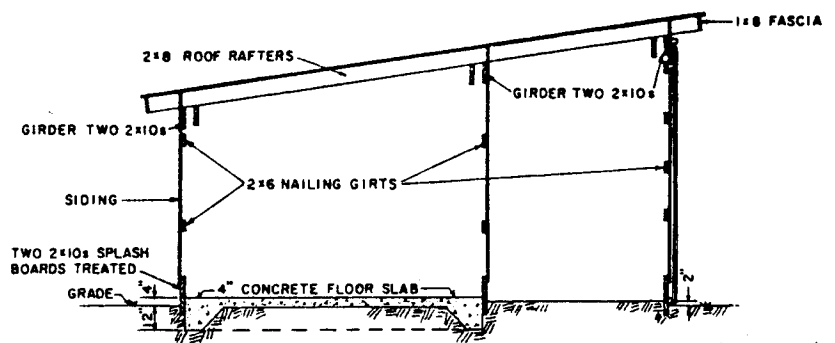
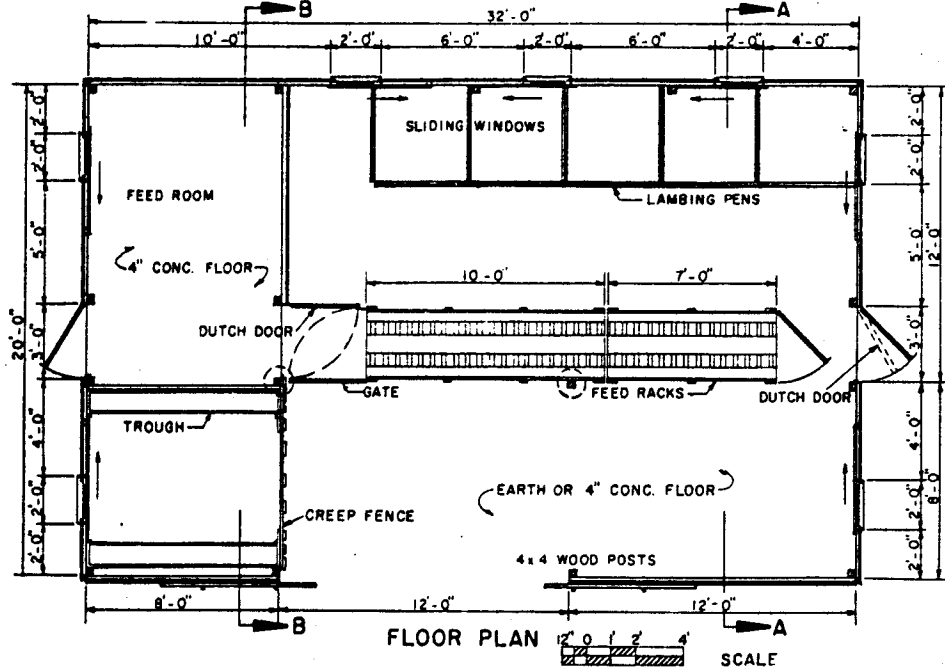

NOTE: THIS BUILDING IS DESIGNED FOR USE IN AREAS WHERE THE SNOW LOAD DOES NOT EXCEED 35 LBS. PER SQUARE FOOT AND WINDS ARE NOT ABOVE 76 MILES PER HOUR.

COOPERATIVE EXTENSION SERVICE  
AGRICULTURE AND HOME ECONOMICS  
The Pa. State University  
AND  
UNITED STATES DEPARTMENT OF AGRICULTURE COOPERATING

**SHEEP AND LAMBING SHED**

USDA '61 5919 SHEET 1 OF 2  
REVISED '84 725-5919

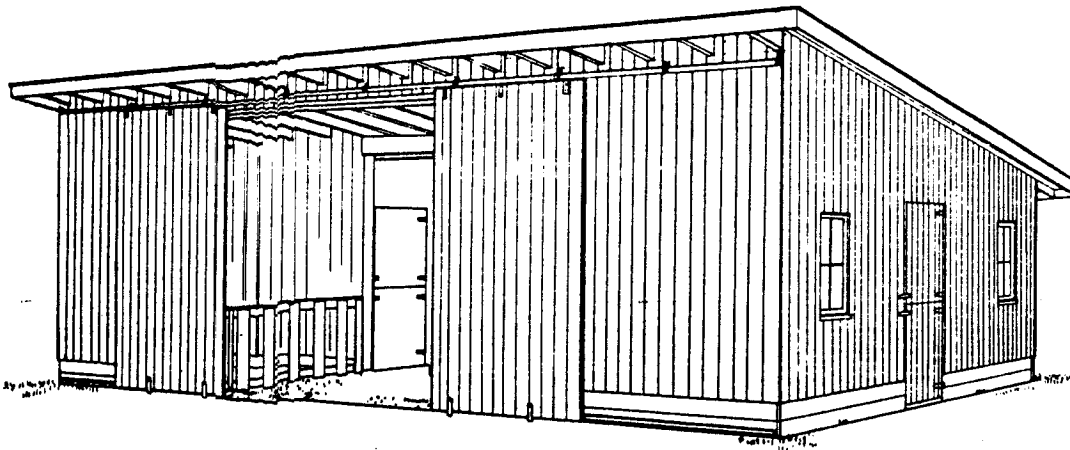

PERSPECTIVE VIEW  
OF COMPLETED SHED

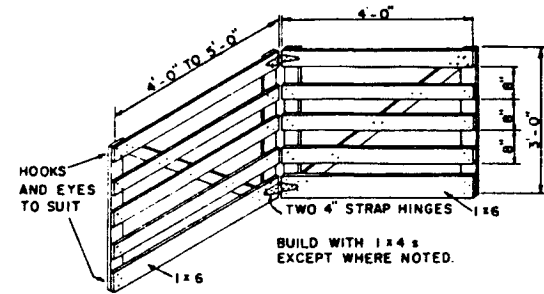

HINGED PANELS FOR TEMPORARY  
LAMBING PENS

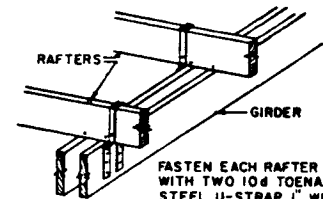
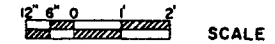

NAILING DETAIL  
NO SCALE

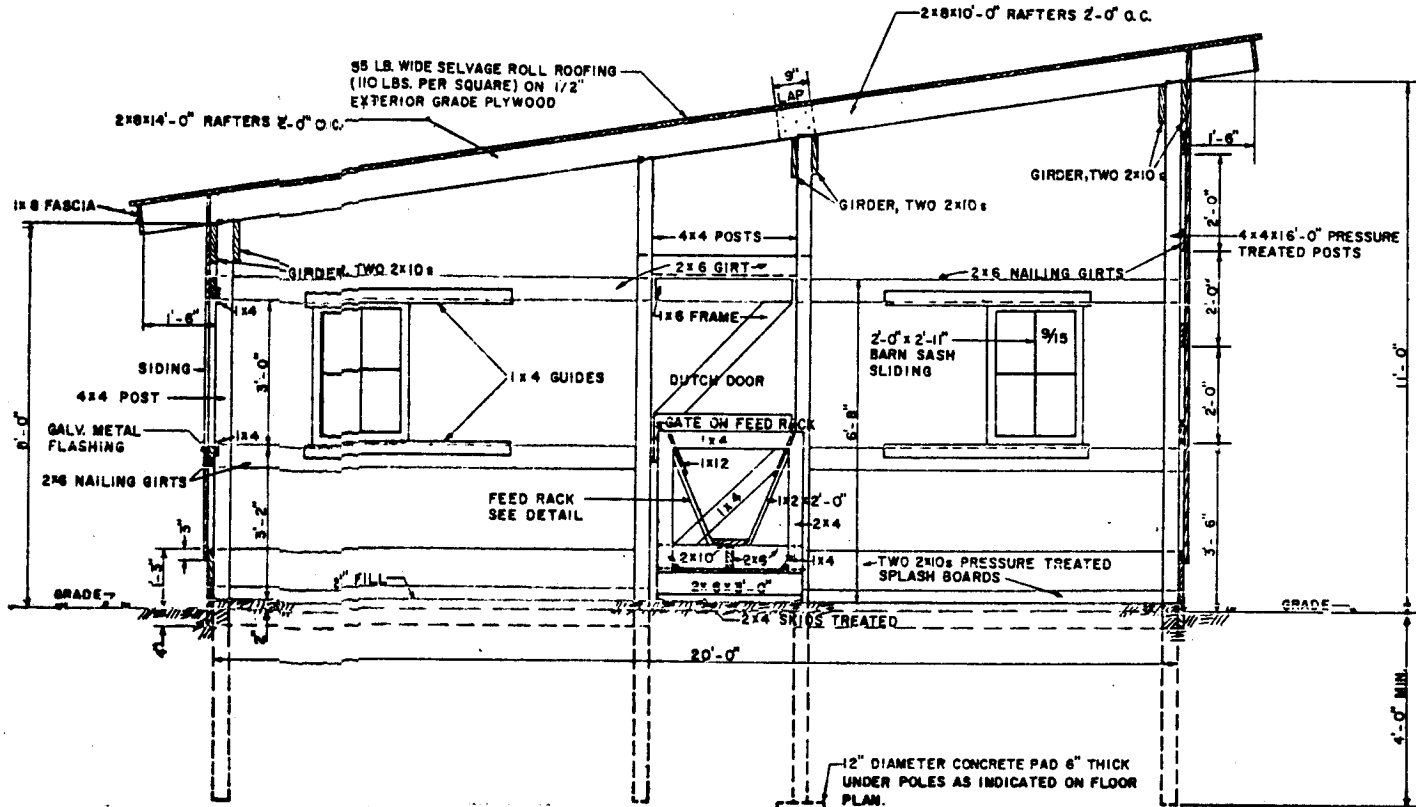

SECTION A-A  
SCALE

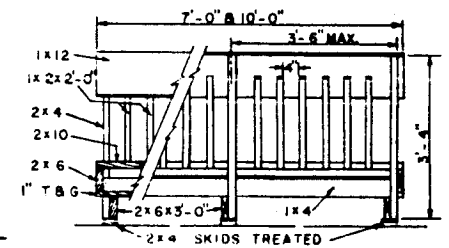

DETAIL ELEVATION OF FEED RACKS

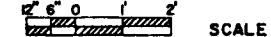

COOPERATIVE EXTENSION WORK IN  
AGRICULTURE AND HOME ECONOMICS  
The Pa. State University  
AND  
UNITED STATES DEPARTMENT OF AGRICULTURE COOPERATING

**SHEEP AND LAMBING SHED**

USDA '61	EX-5919	SHEET 2 OF 2
REVISED '84		725-5919

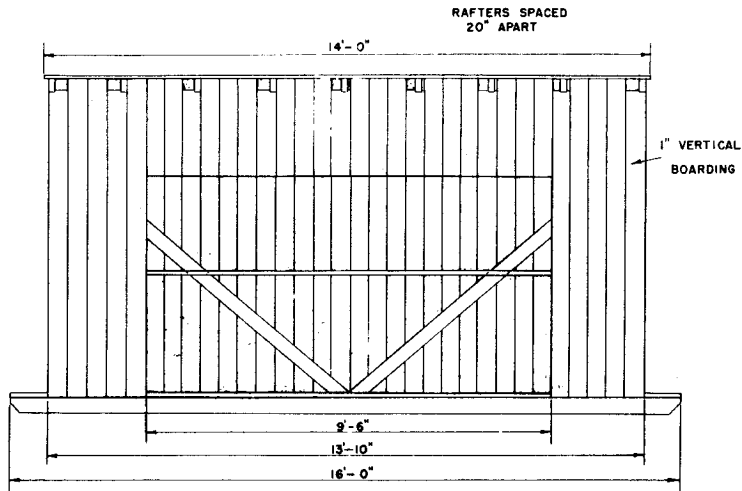

FRONT VIEW

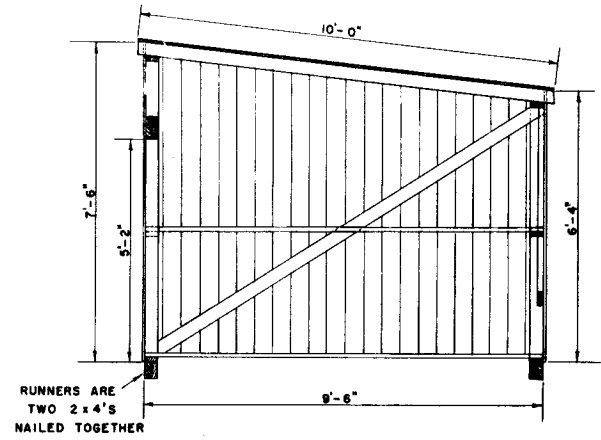

CROSS-SECTIONAL VIEW

**NOTE:**  
ALL WOOD IN CONTACT WITH GROUND  
SHOULD BE TREATED WITH PRESERVATIVE

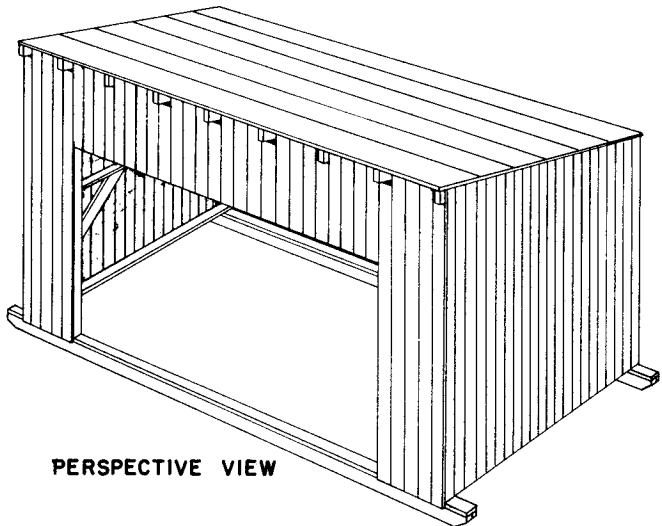

PERSPECTIVE VIEW

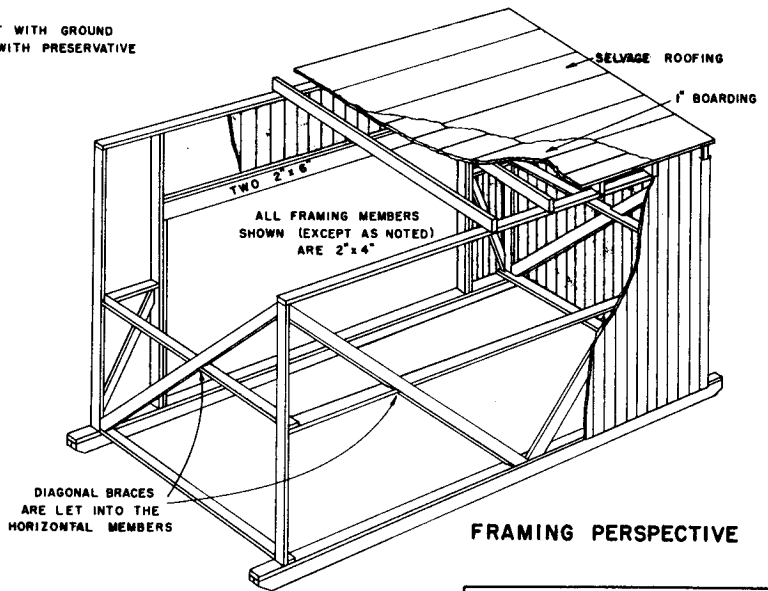

FRAMING PERSPECTIVE

THE PENNSYLVANIA STATE UNIVERSITY AGRICULTURAL EXTENSION SERVICE	
Portable Shelter	
ORDER NO.	SHEET 1 OF 1



SHEEP 201 INDEX ▾

SHEEP 101

OTHER WEB SITES ▾

SEND E-MAIL



High-tensile electric fencing



Close spacing at bottom



Insulators



Charger

## Fencing

Fencing is usually the largest capital expenditure on a sheep farm. In many cases, existing fence can be modified for sheep raising. Two types of fencing are required on a sheep farm: perimeter and interior fencing.

Perimeter fencing is usually installed around the boundary of the property (or grazing area) and is the first line of defense against predators. It is intended to last for a long period of time and should be constructed of high quality materials. Suitable perimeter fences for sheep are multi-strand, high-tensile, electric fences and woven wire fences with electric offset wires and barbed wires at the top and bottom of the fence.

Interior fences (or cross fences) are used to subdivide fields into smaller areas (paddocks) for effective grazing management. Interior fences may be constructed from permanent, semi-permanent, or temporary fencing materials.

While an interior fence does not need to deter predators, it may need to be good enough to keep weaned lambs away from their dams and/or rams away from ewes. Temporary fencing can be used to enclosed areas for temporary grazing (e.g. a corn or wheat field).

### Perimeter Fencing

#### High-tensile, electric

High-tensile electric fences last for a long time, are relatively easy to install, and cost less than other types of fencing. Whereas cattle can often be controlled with 1 or 2 strands of electric wire, sheep require multiple strands, not just to keep them in, but to keep predators out.

Five, six or seven strands of 12 ½ gauge high-tensile wire is common for sheep fences. The bottom wires of the fence are more closely spaced than the top wires. Wire spacings of approximately 6, 5, 5, 8 and 10 inches are typical. In areas where there is relatively even rainfall and some green vegetation most of the year, it is recommended that all wires be hot.

Ground return wires are recommended where there is low rainfall, stony and dry soil conditions or where the ground is frequently frozen or snow covered. Switches can be installed so that wires can be turned off if the situation warrants. For example, it is useful to put a switch on the wire closest to the ground, so that it can be turned off if there is too much vegetation on the fence line.

High-tensile fences are made with smooth wire pulled to an initial tension of 250 pounds. They require strong corners and end braces to achieve adequate tension. The wire is held on fence posts with staples. These staples are driven at a slight angle off of vertical so the slash cut points steer the staple into different grains of the wood. The staples are not driven tight against the wire, but instead allow freedom for the wire to move during tensioning, temperature changes, or livestock pressure.

#### Grounding

Poor grounding is the leading cause of electric fence failures. An electric fence must be properly grounded so that the pulse can complete its circuit and give the animal an effective shock. It is important to follow manufacturer's instructions for grounding electric fences. A minimum of three ground rods should be used for each energizer. It is estimated that 80% of electric fences in the U.S. are improperly grounded. A voltmeter is an inexpensive tool that measures the charge the fence delivers and can be used to trouble shoot electric fence problems.



Solar fence charger



Cut-off switch

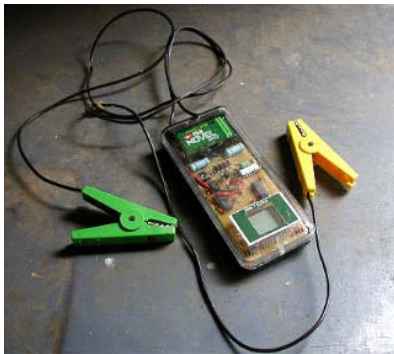

Volt meter



Corner

### The charger

The charger (or energizer) is the "heart" of the electric fence system. It converts main or battery power into a high voltage pulse or "shock" as felt by the animal when it touches the fence. In the past, electric fence chargers shorted out easily. Today's chargers are low impedance, meaning they are designed to effectively shock though vegetation and other foreign materials touching the fence.

A 4,000 volt charger is usually sufficient for sheep. The number of joules needed depends on the length of the fence, the number of electrified wires and the severity of conditions. A joule is the amount of energy released per pulse. As a general rule, 1 joule will power 6 miles of single fence wire; 4.5 joules is usually adequate for 20 to 50 acres. Lightning strikes can damage energizers. Surge protectors and lightening arrestors are recommended to minimize energizer damage.

High tensile electric fencing requires periodic upkeep. Fence wires should be kept properly tensioned. Weeds and brush should be cleared from the fence line by spraying or mowing.

It is important to note that an electric fence much more of a psychological barrier rather than a physical one. Sheep and lambs must be trained to respect electric fence. Once trained, they will usually respect the fence even if it is off for any reason.

### Woven Wire (American Wire, Page Wire)

Woven wire is the traditional type of fencing for sheep. It consists of horizontal lines of smooth wire held apart by vertical wires called "stays." The distance or spacing between horizontal line wires may vary from as close as 1 1/2 inches at the bottom for small animals, to as wide as 9 inches at the top for large animals. In general, the spacing between wires gets wider as the fence gets taller. Stay wires should be spaced 6 inches apart for small animals and 12 inches for large animals.

A four-foot high woven wire fence, with one to two strands of barbed or electric wire along the top of the fence makes an excellent perimeter fence for sheep. A strand of barbed wire along the bottom of the fence will serve as a "rust" wire and extend the life of the fence.

An electric "offset" wire at shoulder height will keep sheep from poking their heads through the fence. Another offset wire, approximately 7 inches up from the ground will help to deter predators that try to go under fences.

High tensile woven wire fences are more expensive but will not sag or stretch as readily as standard woven wire. They are more resistant to rust and are considerably lighter in weight. Less fence posts are needed with high tensile woven wire.

The advantage to woven wire fences is their effectiveness as a visual barrier. Their biggest disadvantage is their cost.

### Mesh wire

Mesh wire fences have smaller openings than woven wire fences. Two types of mesh wire are the diamond mesh, which uses two wires twisted together in a diamond formation with 2-inch x 4-inch openings, and the square knot mesh, which has single horizontal lines with the wire spaced 2 to 4 inches apart. Because they are more expensive than woven wire, they tend to be used for confinement fencing, such as corrals and barnyards.

### Barbed Wire Fences

Barbed wire fences are generally not recommended for sheep because they do not effectively deter predators and they can cause injury to livestock. Sheep can get their wool snagged in the barbs. Barbed wires should not be charged due to their poor conductivity and safety for the animals.

When barbed wire fences are used they should contain at least 5 to 6 wires, preferably 8 to 10 closely-spaced wires with several twisted vertical stays. The best use of barbed wire is to rejuvenate old fences or enhance woven wire fences. It is common to install 1 or 2 strands of barbed wire along the top of a woven wire fence and/or one wire along the bottom of the fence.

### Rail Fencing (wood or vinyl)

Rail fencing will generally not contain sheep or repel predators unless electric wires are placed between the boards or the entire fence is covered with woven or mesh wire. Rail fences are expensive to build and maintain. On the other hand, permanent, wooden fences are often used for corrals and barnyards.

### Other Types of Fencing

Fences made from hog wire or chain link, while effective are generally too expensive to enclose large parcels of land. They work well for corrals and barnyards and other high pressure areas.

### Rejuvenating Old Fences

Old fences can last many more years by attaching offset brackets and an electrified wire on each side of the old fence. Single off-set wires should be set at two-thirds of the height of the animals to be controlled. The old fence can serve as the ground wire and will work well to complete the circuit and control the sheep.



Warning sign

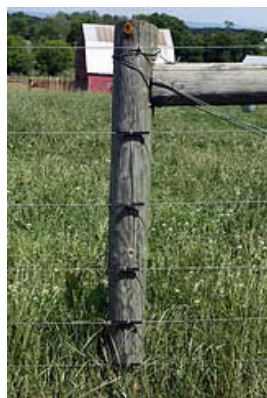

Proper wire spacing



Woven wire fencing



Woven wire fencing



Polywire

**Fence height**

Fences can be built at different heights. Commercial fencing products come in different heights. Most predators climb, go through, or go under fences, as compared to over them.

**Fence Posts**

There are many types of fence posts. Fence post selection should be based on the specific fencing need. For example, treated wood posts are best for permanent boundary fences, while steel or fiberglass posts are suitable for temporary fences. Wood posts are highly variable in size and shape. Strength of wood posts increases with top diameter. Post strength is especially important for corner and gate posts, which should have a top diameter of at least 8 inches.

Brace posts should be 5 inches or more in top diameter. Line posts can be as small as 2 1/2-inches in top diameter, although larger diameter posts make fences stronger and more durable. T-posts and landscape timbers can also be used for line posts.

Steel posts offer a number of advantages. They are lighter in weight, fireproof, extremely durable, and relatively easy to drive. They also ground fence against lightning when in contact with moist soil. Fence posts must be long enough to accommodate fence height, depth of setting, and an additional 6 inches. One of the advantages of high tensile fencing is that it requires less fence posts.

Most fences use a post spacing of 8 ft. whereas the line spacing on high tensile fences varies from 16 to 90 feet. Post spacing needs to be adjusted for topography, livestock pressure, post size, wire tension, and use of poly spacers, battens, or droppers.

**Estimated construction costs for fencing (based on 1,320 feet, 1/4 mile)**

Type	Total cost	Cost per foot
Woven wire, 1 barbed strand	\$1,987.09	\$1.51
Barbed wire, 5 strands	\$1,613.65	\$1.22
High tensile, non-electric, 8 strands	\$1,483.75	\$1.12
High tensile, electric, 5 strands	\$927.13	\$0.70
Electrified polywire, 3 strands	\$309.69	\$0.24

Source: Estimated Costs for Livestock Fencing, Iowa State University, updated 2005.

**Wire**

Wire may be galvanized steel, aluminum, or aluminum clad steel. Several gauges and breaking strengths of wire within the different wire types are available. Steel wire is covered with zinc, commonly called galvanizing, to protect it from rusting. More zinc means more years of service before rusting starts.

High tensile wire typically carries three times as much zinc coating as barbed or woven wire, which accounts for its long expected life. Aluminum wire is lighter, more conductive, and never rusts; however, the breaking strength of aluminum wire is only about one third that of steel wire. A combination of these two materials is also available as aluminum clad hi-tensile steel. This is a hi-tensile steel wire with aluminum coating in place of galvanization. This wire has the high breaking strength of steel wire and the conductivity of aluminum.

12.5 gauge wire is usually the wire of choice for most permanent fences, while lighter gauges can be used for internal subdivision fences, both permanent and temporary.

**Insulators**

Insulators are a fundamental component of any electric fence. They are made from a non-conductive material, such as porcelain or plastic and form a barrier between the electrified wire and its support material to prevent current leakage to the ground. Plastic insulators are the most common type of insulator used on electric fences. They are cheap and easy to fit.

Porcelain insulators have the best insulation properties, and if good quality, are the strongest. They are the most expensive. Plastic tube insulators are useful for taking a line wire around a post. Off-set insulators are used to attach a wire to a new fence or a non-electric fence. Cut-off switches are used to isolate parts of a fence without the need to turn off the energizer.



Tape fencing



Board fence



Board fence



Sheep corral



Electric netting



Electric netting

### Temporary fencing

Different materials can be used to construct temporary electric fences: high-tensile wire, polywire, polytape, and electric netting (or net fence).

#### High-Tensile

Light weight, high-tensile wire (17 or 19 gauge) is most suitable for semi-permanent fences that will not be moved constantly. Two or three wires is usually sufficient to control sheep and lambs.

#### Polywire and Polytape

The most common materials used for temporary fencing are polywire and polytape. Both are combinations of metal and plastic filaments. Polywire has the appearance of heavy cord or plastic baler twine. It comes in several colors or combinations of colors. Several grades are available depending upon the number of filaments and gauge of the conductor. Most polywire sold is either 6 or 9 strand.

Polytape similarly comes in several options and should be purchased on the basis of the number of filaments and the quality of the plastic weave. Compare to polywire, tape has the advantage of greater visibility, which leads to quicker animal recognition and training to the fence. Polywire is less expensive and lasts longer. Poly products come in reels with various capacities and with different locking systems. If you plan to move a fence, reels are an absolute necessity for polywire and polytape.

#### Step-in posts

Plastic step-in posts are the most common line posts used with poly products. They are the easiest to use, especially if the fence will be moved frequently. The pre-molded loops provide plenty of flexibility for wire spacings. The metal re-bar posts are cheaper and last longer than plastic or fiberglass posts. They require insulators to hold the wires and can be difficult to get in the ground when the soil is hard.

#### Fiberglass posts

Fiberglass posts are best suited to situations where the fence will not be moved frequently. Drive caps are usually used to hammer fiberglass posts into the ground. A spent shotgun shell also works well. Wire clips or plastic insulators are used to hold the wire in place. All types of posts can be difficult to install during the winter.

#### T posts

Metal "t" posts are stronger and last longer than the other temporary posts, but they cost more and require more labor to install and remove.

### Electric Netting

Electric netting combines traits of net-wire and electric fencing, providing a formidable mental and physical barrier in a portable format suitable for temporary or semi-permanent fencing of pastures. It is constructed of polywires and plastic twines. It is usually supplied in fixed lengths of 50 or 25 meters with support posts already installed.

Netting is lightweight and easy to install. Compared to other temporary fences, electric netting provides greater protection from predators. However, with electric netting, there is some risk of animal entanglement, especially young lambs and animals with horns.

### Comparison of fencing types

Type	Pros	Cons	Best use
Barbed wire	May already exist on property	Safety Stock control Predator control	In combination with woven wire
Woven wire	Visual barrier Predator control	Cost Installation Entanglement	Permanent Perimeter Holding areas
Stock panels	Visual barrier Strength	Cost Installation	Corrals Holding areas
Mesh wire	Visual barrier	Cost Installation	Perimeter Holding areas
Board Split-rail Vinyl	Physical barrier Aesthetics	Cost Installation High maintenance Stock control Predator control	Estates Farm entrance
High tensile, non-electric	Long life Installation Cost	Predator control	Perimeter Corrals Holding areas
High tensile electric 5 to 7 strands	Long life Installation Cost Predator control	Maintenance of fencelines	Permanent Perimeter Interior



Stock panel

Polywire 2 to 3 wires	Cost Installation	Short life Predator control	Interior Temporary
Polytape 2 to 3 strands	Cost Installation	Short life Predator control	Interior Temporary
Electric 2 to 3 wires	Cost Installation	Predator control	Interior Temporary
Electric netting	Visual barrier Installation	Cost Entanglement Short life	Interior Temporary Small areas
Chain link	May have materials Visual barrier Predator proof	Cost Installation	Corrals Holding areas

<== SHEEP 201 INDEX

Late updated 11-Feb-2010 by Susan Schoenian.  
Copyright© 2010. Sheep 101 and 201.



# TYPES OF FENCING FOR GOATS

**Steve Hart**

*E (Kika) de la Garza Institute for Goat Research  
Langston University  
Langston, Oklahoma 73050*

## Introduction

Anyone that has goats knows that fencing them in is one of the greatest challenges of having goats. A Texas adage says that if you can see through it or blow smoke through it, it won't hold a goat. However, it is possible to keep goats in your pasture without spending a mint on your fencing. This article describes several different types of fencing that have been used to keep goats in successfully and the cost for materials. This article also covers several methods of converting 5-strand barbed wire fence to a goat fence and several types of electric fence that have been used with goats. One area of difficulty is fencing water crossings. Considerable attention must be given to this because goats unlike cattle are very good at finding gaps in the fence to escape. Most of the fence types that hold goats will also hold the debris in water and therefore will have to be a tear-away type of structure for one end to give away when debris accumulates on them, but they will have to be repaired before the water goes down enough to allow the goats to escape. Generally goats will not walk through water or get their feet wet.

One last thing to mention is that in a few cases names of particular brands of fencing materials may be mentioned. This does not imply an endorsement by the Institute of this product or that other brands might not be equally suitable.

## 1. Goat Net Wire Fence

Goat net wire is a net wire fence (Sheep and Goat Wire designated 10-47-10-121/2) that is topped with a strand of barbed wire. It can be put on steel or wood posts. It has been fastened to existing 5-strand barbed wire with hog rings, but if the barbed wire is rusty, it will hasten the rusting process of the net wire. The barbed wire on top is necessary to keep cows and horses from putting their heads over the fence and stretching the net wire down low enough for goats to escape. People crossing the fence will also stretch the net wire. The shorter version of sheep and goat net wire can be used (8-35-12 sheep and goat wire) can also be used in this way, but requires being topped by several strands of barbed wire. Do not use conventional field fence(8-35-6) because goats will become caught by the horns and starve or be eaten by predators. If you have this type of fence already, the only solutions are to replace it, cut every other vertical wire, or to put one strand of electric fence in front of it.

This type of fence is a very secure fence for goats, although very young small kids can escape through the holes, but they will remain close to their mothers.. It is somewhat expensive. Post spacing can range from 10-25' depending on terrain and animal pressure. The cost for 1/4 mile of this fence with one set of corners and two line braces and the list of materials needed is as follows:

4 rolls of 10-47-12 sheep and goat wire	@\$68 each	\$272
1 roll of 4 pt barbed wire	@35 each	35
105 T-posts, 7 ft long (12-ft spacing)	@2.83 each	297
2 line braces (wood posts and brace)	@28 each	56
1 corner brace	@43 each	43
<i>Total cost of materials</i>		703

## 2. Barbed Wire - 10-12 strand

This fence is a very secure fence that keeps goats in and is difficult for humans to cross. This tends to be one of the more predator-resistant types of fence. It is composed of a number of strands of barbed wire that are closely spaced with wire stays every 4-5 ft to hold the wires in alignment. The wires are spaced 3-3.5 inches apart at the bottom and increased to 4, 5, and 6 inches between the wires towards the top of the fence. Post spacing can be 10-15 ft. Since there are so many strands of barbed wire under tension, careful attention must be given to having a stout set of braces to hold the tension of wire. The cost for 1/4 mile of this fence with one set of corners and two line braces and the list of materials needed is as follows:

12 rolls of barbed wire	@\$24 each	\$288
105 T-posts, 6 ft long (12-ft spacing)	@2.83 each	297
2 line braces posts and horizontal	@28 each	56
1 corner brace	@43 each	43
<i>Total cost of materials</i>		<i>684</i>

## 3. Converting 5-Strand Barbed Wire Fence with Addition of 4 Strands of Barbed Wire

This is a fairly economical way to convert 5-strand barbed wire to be goat proof, but also requires considerable labor. Two strands are added to the gap between the lowest strand and the ground and 1 additional strand of barbed wire between the lowest and second strand of barbed wire and 1 additional strand of barbed wire between the second and third strand of the existing fence. Wire stays must be added every 3-5 ft. The cost for modifying 1/4 mile of this fence and the list of materials needed is as follows:

4 rolls of barbed wire, 'Gaucho'	@\$24 each	\$96
7 lb of staples	@1.50 each	8
200 wire stays	@0.35 each	70
<i>Total cost of materials</i>		<i>174</i>

## 4. Converting 5-Strand Barbed Wire fence by Addition of 8-35 Net Wire Fence

In this fence conversion, the lowest strand of barbed wire is moved to ground level, the next two strands are moved to between the top wires, and net wire is used to fill the gap in between. Considerable labor is also involved in this conversion of fence, but it is a relatively secure type of fence. The cost for modifying 1/4 mile of this fence is as follows:

4 rolls of 8-35-12 sheep and goat wire	@\$56 each	\$224
10 lb of staples	@1.50 each	15
<i>Total cost of materials</i>		<i>227</i>

## 5. Converting 5-Strand Barbed Wire Fence with Addition of 1 or 2 Strands of Electric Fence

This is the cheapest and fastest method for conversion of 5-strand barbed wire fence enabling goats to be used in areas that would be prohibitively expensive to fence and use for goats otherwise. Although it is the least secure type of fence it gives acceptable levels of animal control. Young kids can escape under it, but will stay close to the doe. Electric fence does not work well for everyone's management style and can be another

management problem if you do not have several years of successful use of electric fence behind you. There are three rules for successful electric fence use with goats: 1) construct it properly with quality materials; 2) train animals to electric fence before turning them out; and 3) keep the fence hot (minimum 4,500 volts) by checking it daily. Find someone who has used electric fence successfully for a long time and learn their techniques and the materials they use. Half the problems with electric fence are due to poor quality components and(or) poor construction techniques. When an animal gets his head through the electric fence before getting shocked, most likely, he will go forward and out. Therefore, it is profitable to spend a couple of days training animals in a trap or pen lined with a similar type of electric fence to what you are using. Aluminum soft drink cans can be crushed and put on the wire to attract animals to the wire. Bales of hay or feed in a trough can be used to attract animals into the fence. It only takes a couple of days to train goats. To keep fence hot, you need to put a voltmeter on the fence every day. There are some new sophisticated electric fence voltmeters which not only tell the voltage, but will tell whether the short is to the left or right of the voltmeter. When the voltage is low, get it fixed before the goats find out. Falling limbs can also short an electric fence. Vegetation can also be a problem on the fence and can be sprayed with herbicide or clipped with a weedeater. Roundup can be sprayed from a 4-wheeler to cover a lot of area fast. Also, it does not take long to discover that a high quality fence charger is worthwhile investment. Expect to pay \$100-600 for a quality fence charger. Never underestimate the importance of a good ground. Follow the manufacturers directions on grounding to avoid grounding problems. Generally plug-in type fence chargers are cheaper for the amount of power and are more reliable than solar powered chargers. However, in remote areas, solar powered chargers are a necessity.

One strand of electric fence can be added to a barbed wire fence in many ways. It should be 14-16" high and have posts and insulators every 30-35 ft. It must stand out from the existing fence at least 5-6 inches or more to keep the electric fence wire from becoming entangled in the barbed wire. Many of the stand-off insulators fitting on T posts are 5 inches long. If two strands of electric wire are to be used, they should be 8" and 18" high. This will help with predator control and is more secure than one strand of electric fence. Although, a common recommendation is to place the lowest line of electric fence wire between the ground and the first strand of barbed wire, and the second line between the first and second barbed wire strands. Quality stand-off insulators which fit on existing posts can be used. Stand-off insulators allow the fence to be weed-eated under easier. Some stand-off insulators are poor quality and subject to breakage. Good quality standoff insulators are often more expensive than using short posts. Other materials than can be used for posts include temporary step-in posts, homemade posts from 1" PVC electric conduit (stabilized against the sun), fiberglass sucker rod, or 2" x 6.5 ft posts cut in half (3 ft) and fitted with an insulator. The cost for converting 1/4 mile of fence is as follows:

1/3 roll of 12 gauge high tensile wire	@\$55/roll	\$19
PVC posts 45 posts	@0.80 each	36
Wire clips, pk of 50	@3.40 each	3.40
1/4 of a shocker and ground rod	@300 each	75
<i>Total cost of materials for 1-strand electric fence</i>		<i>133</i>
<i>Total cost of materials for 2-strand electric fence</i>		<i>153</i>

Don't forget a quality electric fence charger, ground rod, lightning arrester, voltmeter, gate handles, and underground wire.

## 6. Temporary Electric Fence

Four-strand temporary electric fence on step-in posts with three strands of Maxishock (small galvanized cable from Premier) topped with Intelli-Rope, a rope that has wire conductors, gives visibility to deer to keeps them from tearing the electric fence down. This type of fence works well on keeping goats in and provides some

protection from predators. Four wires spaced 8 inches apart has worked well for us. Corners and ends can be landscape timbers. The cost for 1/4 mile of this fence with one set of corners is as follows:

45 step in posts	@\$2.05 each	\$92
Three strands Maxishock	@70 each	210
One strand Intelli-Rope	@62 each	62
One landscape timber	@2.60 each	3
Corner insulators (4)	@0.60 each	2
<i>Total cost of materials</i>		<i>369</i>

## 7. Permanent Electric Fence

Permanent electric fence is easy to put up and not under as much tension as a barbed wire fence. It provides a significant degree of predator control. Five strands, placed 6, 13, 21, 31, and 43 inches from the ground, work well for goats. Sucker rod posts (\$5.15) and fiberglass T posts are expensive (\$5.60); steel T posts with pinlock insulators (\$3.50) and wood posts (2") with quality insulators (\$2.60) are less expensive. A problem in the use of steel posts with insulators for electric fence is that when the wire gets knocked off of the insulator, the wire may contact the steel T post, causing a direct short to ground.

The cost for 1/4 mile of this fence (5-strand electric fence with sucker rod posts every 30') is as follows:

Sucker rod posts 45	@\$5.15 each	\$232
Wire 1 2/3 roll	@55 each	91
Wire ties, 5 pk of 52	@3.40 each	17
Landscape timber posts for corners (3)	@2.60 each	8
1/4 of electric fence charger and grounding	@300 each	75
<i>Total cost of materials for 1/4 mile</i>		<i>423</i>

## 8. Gallagher Electric Fence

This fence uses Insultimber posts made from Acacia wood (very hard wood) at 90' spacings with 2 wooden battens in between the posts and 5 strands of high tensile wire.

Posts, 13	@\$4 each	\$52
Wire, 1 2/3 roll	@55 each	91
Battens, 26	@2.80 each	73
Wire clips, 5 pk of 50	@3.40 each	17
<i>Total cost of materials for 1/4 mile</i>		<i>233</i>

## 9. Least-Cost Electric Fence - 4 Strands, 2"-Post Every 90', with 2 Fiberglass Battens Between

Wood posts, 13	@\$2.60 each	\$34
Fiberglass battens, 26	@1.20 each	31
High tensile wire, 1.25 rolls	@55 each	70

Landscape timbers, 1.5	@2.60 each	4
Fence clips, 2 pk of 50	@3.40 each	7
Shocker used on 4 miles of fence	@400 each	25
<i>Total cost of materials for 1/4 mile</i>		<i>171</i>

## Summary

There are many fencing options and such a diversity of materials. Cost and what is available at the local store are not important factors in determining what components to use in a fence. The labor required to find and replace one poor quality insulator in a fence will cost more than the whole package of high quality insulators. The loss of one quality animal due to poor quality fencing will pay for the difference in cost of quality materials. The fencing garden at Langston is designed to expose you to these options so that you can determine what type of fencing and components are most appropriate for your farm.

*The proper citation for this article is:*

*Hart, S. 2001. Types of Fencing for Goats. Pages 44-49 in Proc. 16th Ann. Goat Field Day, Langston University, Langston, OK.*

<http://www.luresext.edu/goats/library/field/hart01.html>

Accessed 8/20/10



**UF** Extension

PB1541

---

**Planning &  
Building**

**FENCES**

**on the Farm**

---

THE UNIVERSITY of TENNESSEE **UF**  
INSTITUTE of AGRICULTURE

# Contents

<b>Purpose of the Fence .....</b>	<b>4</b>
Cattle.....	4
Sheep .....	4
Horses.....	4
Swine .....	5
<b>Planning The Fence .....</b>	<b>5</b>
Locating Permanent Fences.....	5
Locating Temporary Fences .....	5
<b>Selecting The Proper Fence.....</b>	<b>6</b>
Woven Wire Fences.....	6
Barbed Wire Fences .....	6
Board Fences.....	7
High-Tensile Fences.....	7
Cable Fences .....	7
Electric Fences .....	9
Comparing Fences .....	9
<b>Fencing Materials and Equipment .....</b>	<b>10</b>
Fence Posts.....	10
Wire.....	10
Staples.....	11
Gates .....	11
Electric Fence Controllers .....	11
Grounding .....	12
Lightning Protection.....	12
Precautions .....	13
<b>Construction .....</b>	<b>13</b>
Choosing the Fence Line.....	13
Corner, End and Line Brace Assemblies .....	14
Setting Fence Posts .....	15
Running Wire .....	15
Tensioning Wire .....	17
<b>Repair and Maintenance .....</b>	<b>17</b>
<b>References .....</b>	<b>18</b>

# Planning and Building Fences on the Farm

*Michael J. Buschermohle, Professor, Agricultural Engineering*  
*James B. Wills, Professor, Agricultural and Biosystems Engineering*  
*W. Warren Gill, Professor, Animal Science*  
*Clyde D. Lane, Professor, Animal Science*

Many innovations have occurred in the fencing industry in recent years, giving producers an array of options for fences to confine and protect livestock. Whether used as permanent, periphery boundaries, temporary pasture dividers or to encircle a house, fences need careful planning and construction for efficient usefulness, long life and low maintenance.

Several decisions must be made when installing fencing. First, what is the fence to be used for? For example, is it going to be a boundary fence or a cross-fence to divide a pasture? Is the fence for sheep, cattle, horses or something else? What type of fence is best suited and where should the fence be constructed for maximum effectiveness?

Other considerations include the type, spacing and setting of posts, gate location and construction, brace post assembly and installation of stock gaps or cattle guards. This publication is designed to help in planning a new or renovated fencing system.

## Purpose of the Fence

The first consideration in deciding the best fence is the purpose for which it will be used.

Livestock protection and confinement are the main reasons for considering fencing, but the fencing needs for various types (species, age, breed, production system) of livestock vary widely. Following are some of the livestock types and situations with special requirements:

### Cattle

Most types of fence can be used with cattle, so most cattle producers assess factors such as expense, ease of construction and expected life of the fence when considering fencing strategy. In the past, woven wire and barbed wire were the most common fence types; however, high-tensile fencing is rapidly gaining popularity in Tennessee. Fence height for perimeter cattle fences should be a minimum of 54 inches.

When bulls are penned separately from cows, special attention must be paid to construction. Heavy posts with thick-gauge wire or cables are required, or electric fence may be effectively used.

Fences for handling facilities must be strong enough to withstand heavy usage, tall enough (60 inches minimum) to prevent escape, and clearly visible. Treated wood or heavy wire panel fences are preferred.

### Sheep

Fences for sheep do not have to be as tall as for cattle, but sheep have other special requirements. Predator control is more important. Electric fences are particularly useful for discouraging predators such as dogs and coyotes. Barbed wire is not as effective with sheep, as the barbs tend to become covered with wool.

### Horses

Visibility is a necessary characteristic in fencing for horses. Barbed wire should be avoided because there are many opportunities for horses to tear their hide on the barbs. High-tensile wire fences poses a threat to horses because they may become entangled in the strands. The chance of



this can be decreased if high-tensile fences are made more visible by placing posts closer together, or hanging ribbons or something else from the wire. Board fences are ideal for horses. Woven wire also works well, particularly with a single board at the top so the horses can easily see the fence.

### **Swine**

Swine require strong fences that are built close to the ground to prevent them from escaping by rooting underneath the fence. Barbed wire along the ground helps prevent rooting. Fences need to be no higher than 54 inches.

As with cattle-working pens, fences around swine confinement units are likely to receive heavy usage. Use heavy materials and sturdy construction for long life and functionality.

## **Planning The Fence**

Fencing is a costly investment. The location and arrangement may affect production efficiency, so it makes good sense to plan before you build. This is true whether you are installing a fence around the farm or a pasture for the first time, or replacing an old, worn-out fence. Evaluate existing fences. If they are in good shape, you may want to plan new fences around them. If they are old and falling down, it may be cheaper in the long run to replace them.

Pay attention to water resources when planning your fence arrangement. Wise placement of fences can result in being able to use the same water source in two, three or even three or more pastures. Fencing cattle away from ponds and using freeze-proof overflow tanks can improve water quality and prevent disease problems associated with cows standing in the ponds during the summer. This also prevents injury and death due to cattle breaking through frozen ponds in the winter. Plans and information about these types of watering systems may be found at your local Extension office or through the Soil Conservation Service.

### **Locating Permanent Fences**

Permanent fences should be well constructed using high quality materials so they will last a

long time with minimum repairs. A well-constructed permanent fence that surrounds the farm is essential. It establishes a fixed property line between you and your neighbors and prevents losses due to livestock getting killed on the highway or having to pay your neighbors for livestock damage to their crops. Take care to properly locate the property line when building boundary fences to avoid costly mistakes.

Consider permanent fencing around pastures which will be used year after year and around cropland. These fences will probably never be moved, so it makes sense to build a well-constructed, low maintenance fence that will last a long time. A permanent fence is also a good idea for a lane that gives livestock access to water.

### **Locating Temporary Fences**

Movable fences are considered temporary fences. They are normally used for a short period of time, then removed and used in some other location or stored until needed. They are easy to build and take down. They cost less than permanent fences, but they are not as effective and usually will not last more than one to three years. They do not take the place of permanent fences, but can be very beneficial in some instances.

Temporary fences are well suited for controlled grazing situations because pastures can be divided into a substantial number of individual cells with minimal labor and cost. They can be moved from year to year until you decide the field layout that best fits your production scheme.

### **Locating Lanes and Gates**

A lane is needed to connect livestock buildings, working facilities and water with every field that eventually may be pastured. Keep in mind that a permanent pasture located between other fields can serve as a lane.

To keep gullies from forming on rolling land, plan the lane to follow a terrace or natural ridge. If a well-drained location is not possible, use movable fences which can be relocated every few years. Wherever possible, locate gates and passageways for livestock and equipment in the corner of each field closest to farm buildings. If you have fields on opposite sides of a road, locate gates opposite each other so livestock can go directly across.

## Selecting The Proper Fence

There are many types of fences to meet various fencing needs. Since fencing usually represents a rather large investment on most farms, it is especially important to select a fence that is affordable, easy to maintain, durable and, most importantly, keeps livestock in. The kinds of fences commonly used in Tennessee include woven wire, barbed wire, high-tensile, board, electric or a combination of any of these.

### Woven Wire Fences

Woven wire fences consist of a number of horizontal lines of smooth wire held apart by vertical wires called stays. The distance or spacing between horizontal line wires may vary from as close as 1 1/2 inches at the bottom for small animals, to as wide as 9 inches at the top for large animals. In general, the spacing between wires gets wider as the fence gets taller.

Woven wire is available in many combinations of wire sizes and spacings, as well as a number of horizontal line wires and fence heights. The height of most woven wire fencing materials ranges from 26 to 48 inches. The fence height should be selected based upon the animals size and their jumping ability. Stay wires should be spaced 6 inches apart for small animals and 12 inches for large animals.

The standard design numbers listed on the tag describe the wire. For instance, a design number 1047-12-11 indicates the wire has 10 horizontal wires and is 47 inches high, stays are spaced 12 inches apart and stay-and-filler wires (wires between the top and bottom line wires) are 11 gauge wire. The top and bottom wires are generally two sizes larger. Standard woven wire fence sizes are shown in Table 1.

Design #	Horizontal Wires	Height (in.)
635	6	35
726	7	26
832	8	32
845	8	45
939	9	39
949	9	49
1047	10	47
1156	11	56

Table 1. Common Woven Wire Fencing Material

### Barbed Wire Fences

Barbed wire fences are made of two or more strands of smooth, galvanized-coated, steel wire twisted together with two or four barbs spaced every 4 to 5 inches. They are generally classified as either a standard or suspension barbed wire fence.

Standard barbed wire fences usually have three to five strands of barbed wire stretched between posts that are spaced between 15 to 25 feet apart (Figure 1).

The suspension fence has 4 to 6 strands of wire stretched taut so there is no more than 3

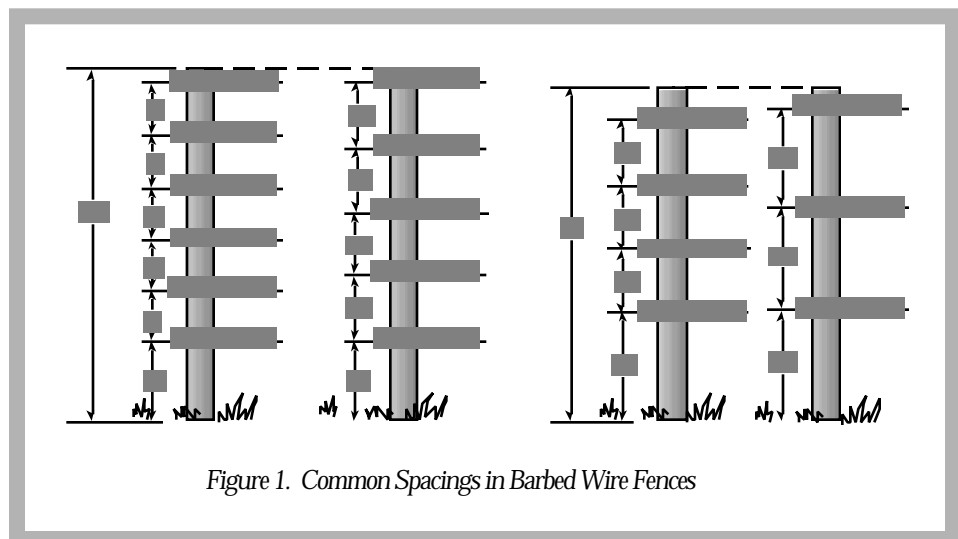

Figure 1. Common Spacings in Barbed Wire Fences

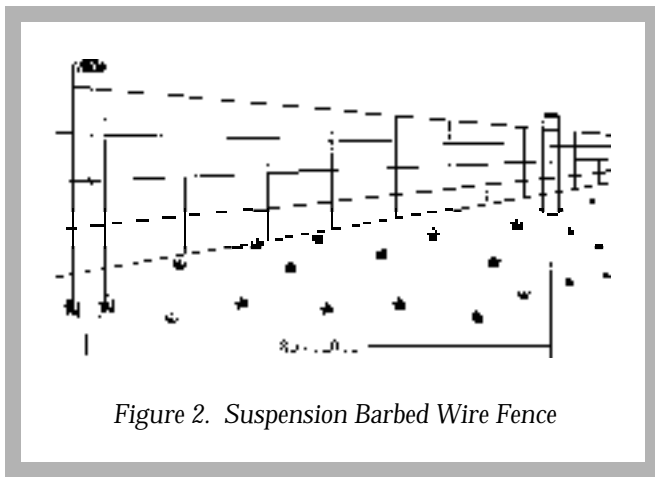

Figure 2. Suspension Barbed Wire Fence

inches of sag between posts (Figure 2). Depending upon the topography, line posts are generally spaced between 80 to 120 feet apart. The wires are held apart by twisted wire stays spaced 16 feet apart. Wind or animals hitting the fence cause it to sway back and forth. This swaying motion keeps animals away from the fence and discourages them from fighting through it. To allow the fence to sway, the stays must not touch the ground or the effectiveness of the suspension fence will be reduced.

### Board Fences

Board fences are very attractive, quite strong and are safe for animals. They are typically used as border fences around the farm or the home. Board fences consist of 1- to 2-inch thick, 4- to 6-inch wide boards nailed to wooden posts spaced 8 to 10 feet apart. They can be built to any height, however, heights of 4 to 5 feet are most common.

The price of lumber, nails, paint and other materials along with the labor required makes the cost of these fences considerably higher than most permanent wire fences. Upkeep is also high, especially if untreated lumber is used.

### High-Tensile Fences

An increasingly popular type of fence is high-tensile wire fence. First used in New Zealand and Australia, high-tensile wire fences offer several advantages over conventional fencing:

- easier to construct
- last longer
- cost less to build than most conventional fences
- require less maintenance

High-tensile fences are constructed mostly with 12 1/2 or 14 gauge Class 3 wires which have tensile strengths from 170,000 to 200,000 or more pounds per square inch (psi) and breaking strengths of approximately 1,800 pounds (Figure 3). This fence can withstand more than 1,100 pounds of livestock pressure without losing its elasticity, yet it is flexible enough to bend, wrap, tie in knots or clamp with crimping sleeves. Wires are held in tension along wood, fiberglass, insulated metal posts or a combination of posts and battens or droppers. Tension in the wire is maintained by permanent in-line strainers. Adequate tension for 12 1/2 gauge high-tensile wire is 200 pounds. A tension indicator spring is used to indicate wire tension.

High-tensile wire fences should be used with electricity to improve animal-holding capability and predator control. It is important to use treated wood posts and set them properly in the ground with adequate braces to withstand the pressure caused by the tightly stretched wire.

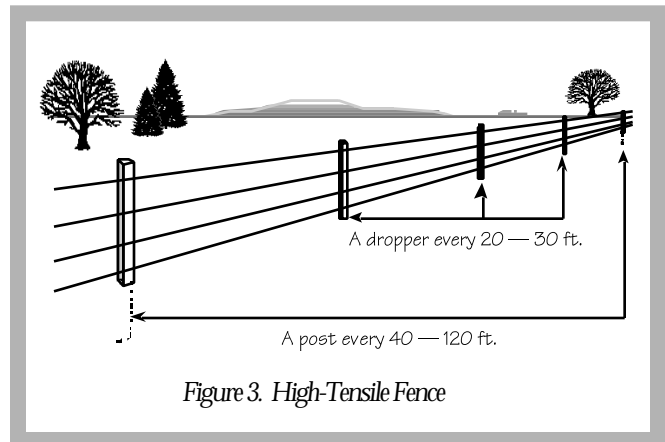

Figure 3. High-Tensile Fence

### Cable Fences

Because of their expense, cable fences are used primarily for confinement areas, such as holding pens, feed lots and corrals. These fences usually consist of 3/8-inch smooth steel wire cables stretched between anchor posts. The cables are normally made out of seven wires twisted together. Heavy duty springs are placed at one end of each cable to absorb the shock on the wires caused by animals pressing against them. Cables are usually passed through holes in wooden or steel posts.

There is no limit as to the number of cables

Permanent Types	Height (in) Spacing(in)	Cost Index <sup>1</sup> (Materials Only)	Approx. Life (Humid Climate) (Years?) <sup>2</sup>	Maintenance	
<b>Barbed Wire</b> <b>2 point, 4-in spacing</b> 3 strands, 12 ½ gage 4 strands, 12 ½ gage 5 strands, 12 ½ gage 3 strands, 14 gage <b>4-point, 5-in spacing</b> 3 strands, 12 ½ gage 4 strands, 12 ½ gage 5 strands, 12 ½ gage	1 post per 16'	12	33	High	
		13	33	High	
		14	33	High	
		11	19	High	
		12	33	High	
		13	33	High	
<b>Suspension Fencing</b> <b>4-point, 5-in spacing</b> 4 strands, 12 ½ gage 6 strands, 12 ½ gage	Posts 100' apart	8	33	Medium	
		10	33	Medium	
<b>Woven Wire</b> <b>Light Weight</b> Top and bottom Wire: 11 gage Filler Wire: 14 ½ gage	Stay Height (in) Spacing (in)	26      6	14	19	High
		32      6	15	19	High
<b>Medium Weight</b> Top and bottom Wire: 10 gage Filler Wire: 12 ½ gage	26      6	16	30	Medium	
		17	30	Medium	
		18	30	Medium	
		20	30	Medium	
<b>Heavy Weight</b> Top and bottom Wire: 9 gage Filler Wire: 11 gage	26      6	19	40	Low	
		21	40	Low	
		23	40	Low	
		25	40	Low	
<b>High Tensile: 12 ½ gage</b> 3 strands 4 strands 5 strands 8 strands		4 <sup>3</sup>	30	Medium	
		5 <sup>3</sup>	30	Medium	
		6 <sup>3</sup>	30	Medium	
		10 <sup>3</sup>	30	Medium	
<b>Temporary</b>					
<b>Barbed Wire: 12 ½ gage</b> 1 strand 2 strands		4	30	Medium	
		5	30	Medium	
<b>Aluminum Wire</b> 9 gage 13 gage		6 <sup>3</sup>	30	Medium	
		5 <sup>3</sup>	30	Medium	

<sup>1</sup>Cost index figures are to show relative cost, no actual cost. For example, fence with an index of 25 costs about twice as much per foot as fence with an index of 12.

<sup>2</sup>Fence life based on combination of post and wire life expectancy.

<sup>3</sup>Costs of electric controller not included.

Table 2. Comparison of Common Fences

that can be used; however, a six-cable fence is often used for large animals. The spacing between cables depends upon the type of animals to be confined.

### Electric Fences

Electric fences are widely and successfully used in Tennessee. They can be an effective, safe and inexpensive means of providing both temporary and permanent fencing if they are constructed properly and energized with a properly sized controller.

Electric fencing does not need to be strong because it seldom comes under pressure, but it must be well designed and constructed to absorb the impact of animals. It is also essential that there is adequate power for the length of fencing and the type of animals to be confined. Several advantages of electric fencing are low cost, inexpensive to operate, can be used to extend the life of old permanent fences or they can be used for deer and predator control. They can be built for temporary or permanent use.

Various types of inexpensive, easily-erected temporary electric fences are available. Probably the most popular are the polywire strands or ribbons which are fine wires woven together with polyethylene fibers.

Polywire comes in various colors. Black is the most difficult for animals and people to see. Brighter colors, such as orange or white, are also available. The polytape, particularly the extra-wide type, is easier to see than polywire. This type works better for horses. It is very important

to keep weeds and grass cut away from the fence, especially when using low impedance controllers. If grass and weeds are allowed to touch most polywires, the charge produced from low impedance controllers can cause the small-diameter wires to burn in two. Polywires with stainless steel wires are more durable, but electric conductivity is lower. Aluminum conducts electricity better, but it breaks more easily.

Aluminum, stainless steel and high-tensile wire can also be used. One advantage to using these type of wires is they conduct electrical charges for longer distances than the small-diameter wires of the polywire and polytapes. However, they are harder for the animal to see. To effectively train animals to stay within an electric fence, the animals need to see the wire as they feel the shock. Tying pieces of white cloth or brightly-colored plastic ribbon will help make these wires more visible.

An electric fence controller is used to energize the wire. The moist earth is used for completing the electrical circuit. Corners and end posts in temporary electric fences require minimal bracing. Line posts can be small and spaced far apart since the fence will generally be used for a short period of time.

### Comparing Fences

As previously stated, when selecting a fence, the things to consider are what the fence is to be used for, how easy it is to build, what it costs to build and maintain and how long it is supposed to last. Table 2 gives some general comparisons

Post Type	Bending strength	Expected life (yrs)	Initial cost	Fire resistance	Maintenance
Steel-T, concrete	Fair	25-30	Medium	Good	Low
Steel rod 3/8" dia	Poor	15-20	Low	Good	Medium
Heavy-duty fiberglass-T	Fair (flexible)	25-30	High	Poor	Low
Light-duty fiberglass-T	Poor (flexible)	15-20	Low	Poor	Medium
Pressure treated wood	Good	30-35	Medium	Poor	Very Low
Untreated wood	Good	7-15	Low	Poor	High

Table 3. Fence Post Characteristics

Kind	Untreated	Treated (Pressure)	Treated (Soak)
Osage O.	25-35 yrs	-	-
R. Cedar	15-25 yrs	20-25 yrs	20-25 yrs
B. Locust	15-25 yrs	-	-
W. Oak	5-10 yrs	20-30 yrs	15-30 yrs
Hickory	2-6 yrs	15-20 yrs	10-15 yrs
R. Oak	2-6 yrs	20-30 yrs	20-30 yrs
Y. Poplar	2-6 yrs	20-25 yrs	15-25 yrs
S. Gum	3-6 yrs	20-30 yrs	20-30 yrs
S. Pine	3-7 yrs	25-30 yrs	15-20 yrs

Table 4. Life Expectancy of Wood Posts

Fence	Spacing (feet)
Woven Wire	14 - 16
Barbed Wire	12 - 14
Suspension	100
Electric	40 - 75
High Tensile	40 -60
Board	8
Corrals	6

\* Driven posts are 1.7 times as strong as tamped posts

Table 5. Recommended Post Spacings\*

you can use to help select the type of fence that best fits your need and budget.

## Fencing Materials and Equipment

### Fence Posts

There are many types of posts available in Tennessee (Table 3). Always try to find the best post to meet the demands of the situation. For example, it is best to use good, treated posts for permanent peripheral fences, while light fiberglass or steel posts would be more suitable for constructing temporary fences in a controlled grazing cell.

Often the least expensive option is to cut your own posts or purchase untreated, wooden posts. They are highly variable in size, shape and durability (Table 4). Osage orange posts have a lifespan of 25 to 35 years, black locust or red cedar posts will last for 15 to 25 years. Other woods such as oak, pine and poplar will rot in just a few years unless they are pressure treated.

Wood posts come in an array of sizes and lengths. The larger the top diameter, the stronger the post. Corners are the backbone of a fence. Whether you plan to install a woven wire, barbed

wire or high-tensile wire fence, the first step is to choose good corner posts. Corner and gate posts should have a diameter of at least 8 inches. Brace posts should be 5 inches or more in diameter. Line posts can be as small as 2 1/2 inches, but larger diameter posts will make the fence stronger and more durable.

Steel posts have several advantages. They weigh less, can be driven into the ground rather easily, won't rot and are fireproof. They also help ground the fence against lightning when the soil is wet. They are more likely to be bent or forced out of line by livestock. A widely used method is to use wooden line posts every 50 to 75 feet to help keep steel posts from bending and improve the strength of the fence.

All posts must be long enough to accommodate the height of the fence and depth of setting. To get the correct fence post length, add together the depth of setting, the height of the top wire and 6 extra inches. Recommended post spacings for various fences are shown in Table 5.

### Wire

Wire is covered with zinc, commonly called galvanizing, to protect it from rusting. The length of time before fence wire begins to rust depends on the thickness of the galvanized coating. The more ounces of zinc per square foot of wire means

more years of service before rusting starts (Table 6).

Fence manufacturers and the American Society for Testing Materials have established “classes” of zinc coatings for fence wire. Class 1 has the lightest coating of zinc and Class 3 has the heaviest. Because of competition, many local fencing supply dealers only stock wire with Class 1 coating. Fencing materials with Class 3 coating may have to be specially ordered. Galvanizing delays rusting. The more galvanizing on the wire, the longer it will be before rust starts to appear.

Once steel wire starts to show rust, it isn’t long before the whole fence is rusted. It usually takes from one to three years from the time rust first appears until all the wire is rusty. The durability of the fence then depends on how fast rust weakens the wire. Rusting slowly reduces the diameter of the wire. As the diameter of the wire gets smaller, its strength is reduced.

### Staples

Selecting the appropriate staple is just as important to the overall strength and longevity of the fence as selecting the right wire. Staple pull-out is a common fencing problem when using pressure-treated softwood posts. The lubricating action of the preservative, combined with the soft nature of the wood, makes it easy for staples to loosen and fall out over time. To avoid this pulling-out action, use 1 3/4-inch or 2-inch long, 8- or 9-gauge, hot-dipped, galvanized staples with cut points and barbs. If you are using untreated hardwood posts, shorter staples can be used because they cannot be pulled out of hardwood very easily.

### Gates

Always place gates in logical places so livestock will move through easily. Avoid putting gates in the middle of a straight fence. It is best to put them in corners. Build or buy sturdy gate materials, especially hardware items such as hinges and closures.

Stock gaps or cattle guards are useful for high traffic areas. Cattle guards can be made of various

	Climatic Conditions			
	Dry		Humid	
	Class 1	Class 3	Class 1	Class 3
Wire Size	Years until rust appears on the wire			
9	15	30	8	13
11	11	30	6	13
12 1/2	11	30	6	13
14 1/2	7	23	5	10

Table 6. Approximate Protection Given Wire by Class 1 and Class 3 Galvanizing

materials, including heavy pipes, railroad rails and wooden beams.

### Electric Fence Controllers

Most producers will agree that touching an electric fence is very unpleasant. The experience for animals are no different. When animals come in contact with an electric fence, the shock they receive affects their nervous system. The severity, or the amount of shock the animal feels, depends on the voltage and amperage as well as the duration of the shock. It takes a minimum shock of 700 volts to effectively control short-haired breeds of cattle, pigs and horses, and around 2000 volts for long-haired cattle, sheep and goats. The controller, often referred to as the charger or energizer, that delivers this shock is the heart of any electric fence and must be selected carefully. There are two types of controllers currently on the market: high- and low-impedance controllers.

Electric fence controllers of years ago, and some brands today, put out relatively high voltage with low amperage. These are known as high-impedance controllers. Because of their high voltage and low current output, there is no staying power of the charge. The first weed or blade of grass to touch the fence will drain the power to the extent that little or no shock is felt by the animal, after even a short distance of fencing.

Low-impedance controllers have the capacity to power long distances of single or multi-wire fence. These controllers put out a lower-voltage,

higher-amperage charge. Their pulse is extremely short compared to high-impedance controllers. Since the pulse length is short, the conductive capacity of the wire isn't saturated. Consequently, there is less impedance or resistance to current flow, resulting in more livestock-influencing energy delivered over miles of fence that weeds and grass won't short out.

If all the fields you plan to fence are not near a 120-volt power source, you have no choice but to use a battery-operated controller. They do an excellent job of confining animals and are very popular controllers because they can be used at any location without connection to a 120-volt power source. These controllers operate on either a 12, 24 or 36 volt (1, 2 or 3 batteries) system. The batteries can be disconnected from the controller and recharged every two to six weeks depending on the type of charger and the amount used. With a solar energy collector kit, the battery can be recharged daily for the life of the battery. Deep cycle, marine and RV type-batteries are best suited for battery-operated controllers. Batteries designed for use in automobiles will not last as long as deep-cycle batteries.

If your fields are near where they can be served by a 120-volt controller, it is probably your best selection. There is no problem of changing or recharging batteries and they cost less than the battery-operated controllers equipped with solar kits. Cost of operation is reasonable, averaging around 50 cents a month.

For good animal control, it is important to match the capacity of the controller to the fence you want to charge. Most manufacturers indicate the strength of the controller by the number of miles it will power. A good rule of thumb for sizing controllers is to determine the number of miles of electrified wire in the fence and add 25 percent to offset any power drain caused by grass and weeds touching the fence. For example, if you have a 5-mile long, 6-strand high-tensile fence and four of the wires are electrified, you would need a controller rated at a minimum of 25 miles ( $4 \times 5 = 20 + 25\% = 25$ ).

## Grounding

Grounding is very important when using electric fence controllers, especially with the low-impedance types. A minimum of three, 6-foot long galvanized ground rods driven in the ground 6 feet apart and tied together with a #12 gauge

copper wire are required for the smaller units (Figure 4). If rocky ground prevents the rods from being driven into the ground, it is recommended the rods be laid end to end in a deep trench and tied together with the copper wire. More powerful units may require a minimum of eight rods. Check manufacturer's recommendations for proper grounding procedures. Make sure ground rods are at least 50 feet from any utility company ground rod, underground telephone or power cable. Firmly attach the ground wire to each rod with ground clamps.

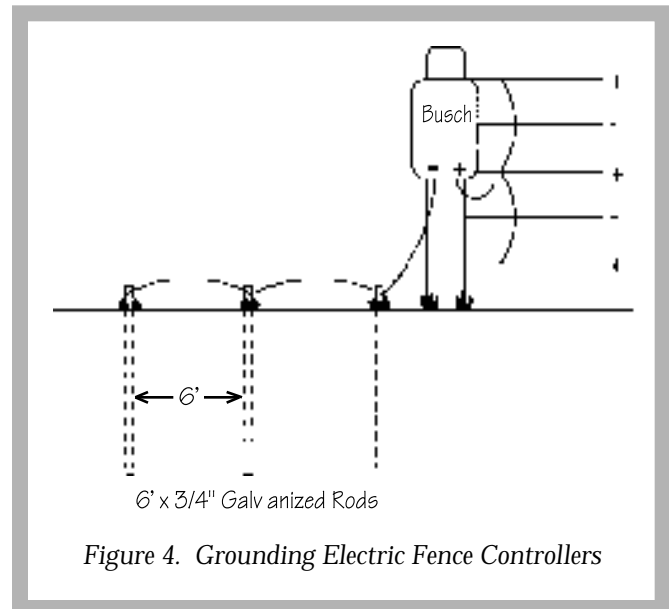

Figure 4. Grounding Electric Fence Controllers

## Lightning Protection

Lightning strikes are a major problem with electric fences. It is rather common for lightning to hit a wire fence directly or indirectly through a tree or building near the fence, and then travel as far as two miles on the fence before it is grounded. Whenever possible, disconnect the charger from the fence line during a thunderstorm.

The best and least destructive way to protect electric fence controllers is to provide a quick path to ground for the lightning charge. Lightning arrestors and chokes offer some protection against lightning strikes, although they do not guarantee complete protection and will not protect the controller from a direct strike (Figure 5). The choke blocks the extremely high voltage lightning strike from getting to the charger by making it



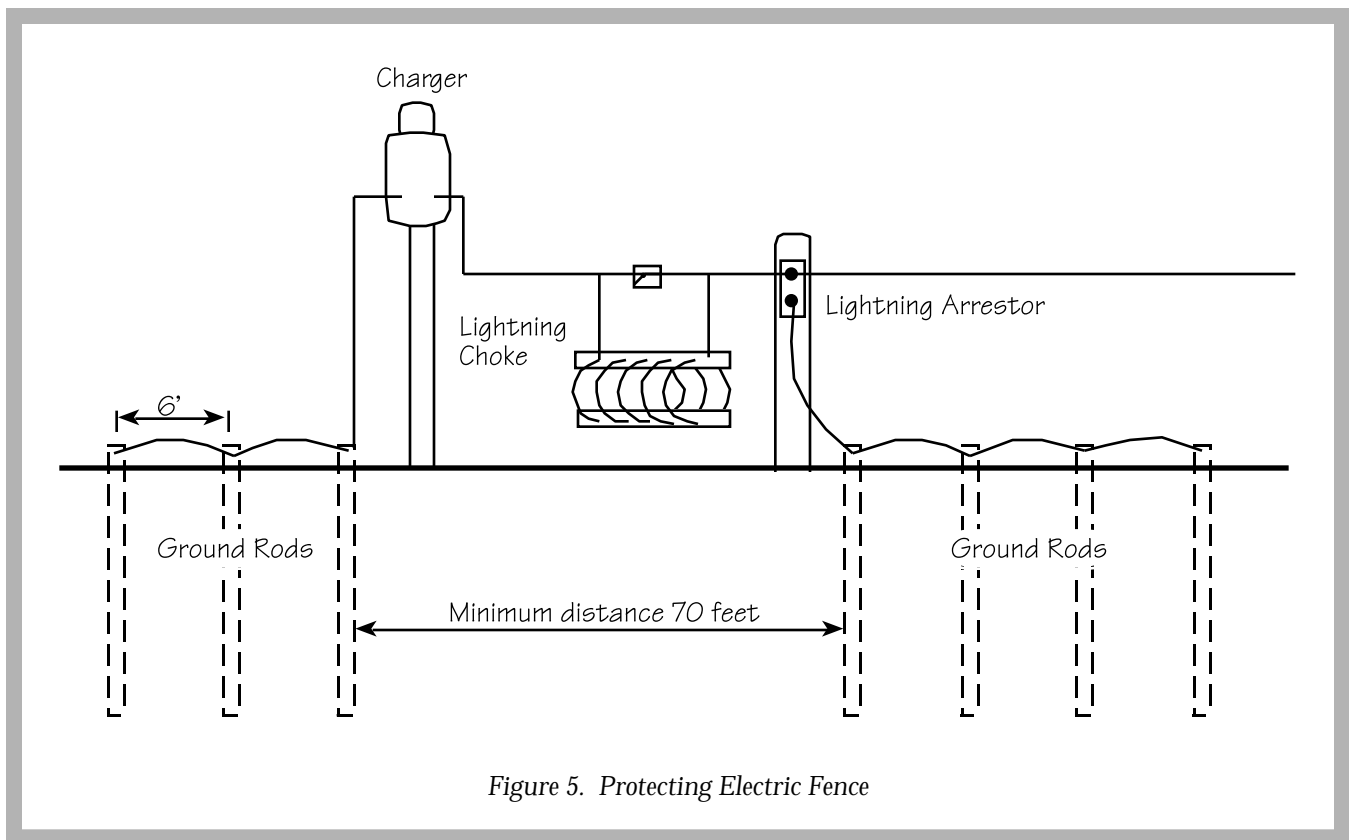

Figure 5. Protecting Electric Fence

jump the carbon discs inside the lightning arrestor, then disperses the charge to ground. Lightning always finds the quickest and easiest way to earth. Thus, earth/grounding system of the lightning arrestor must be as good as, or better than, the grounding system of the controller. In bad lightning areas, grounding the top wire of the fence has helped protect the controller.

### Precautions

- Never use home-made electric fence controllers. Numerous deaths to both humans and animals have occurred from the use of home-made controllers.
- Do not tamper with or attempt to repair the controller. Repairs should be made only by an authorized service agency or the manufacturer.
- Use only one controller on any one continuous fence.
- Never charge a battery on a battery-type controller with the charger connected to the fence.
- Never attach your electric fence wire to a utility pole. Leaks from high voltage current

down a wet pole can be very dangerous.

- Fasten yellow signs with *Electric Fence* painted on both sides to the fence at distances no more than 200 feet apart.

## Construction

Building a fence requires good materials, proper construction techniques and good common judgment. Every fencing job presents slightly different problems. The following steps are typically followed in constructing a high-tensile wire fence. Detailed instructions are provided by most distributors of high-tensile wire fence products. Many of the same techniques apply to the construction of barbed wire and woven wire fences.

### Choosing the Fence Line

First, carefully plan your fencing arrangement. Check property lines closely and arrange cross-fences to take maximum advantage of your situation. The fence line should, if possible, avoid rough, stony, broken, steep areas. With electrified high-tensile fencing it is easier to zig zag a little rather than go straight over places which may

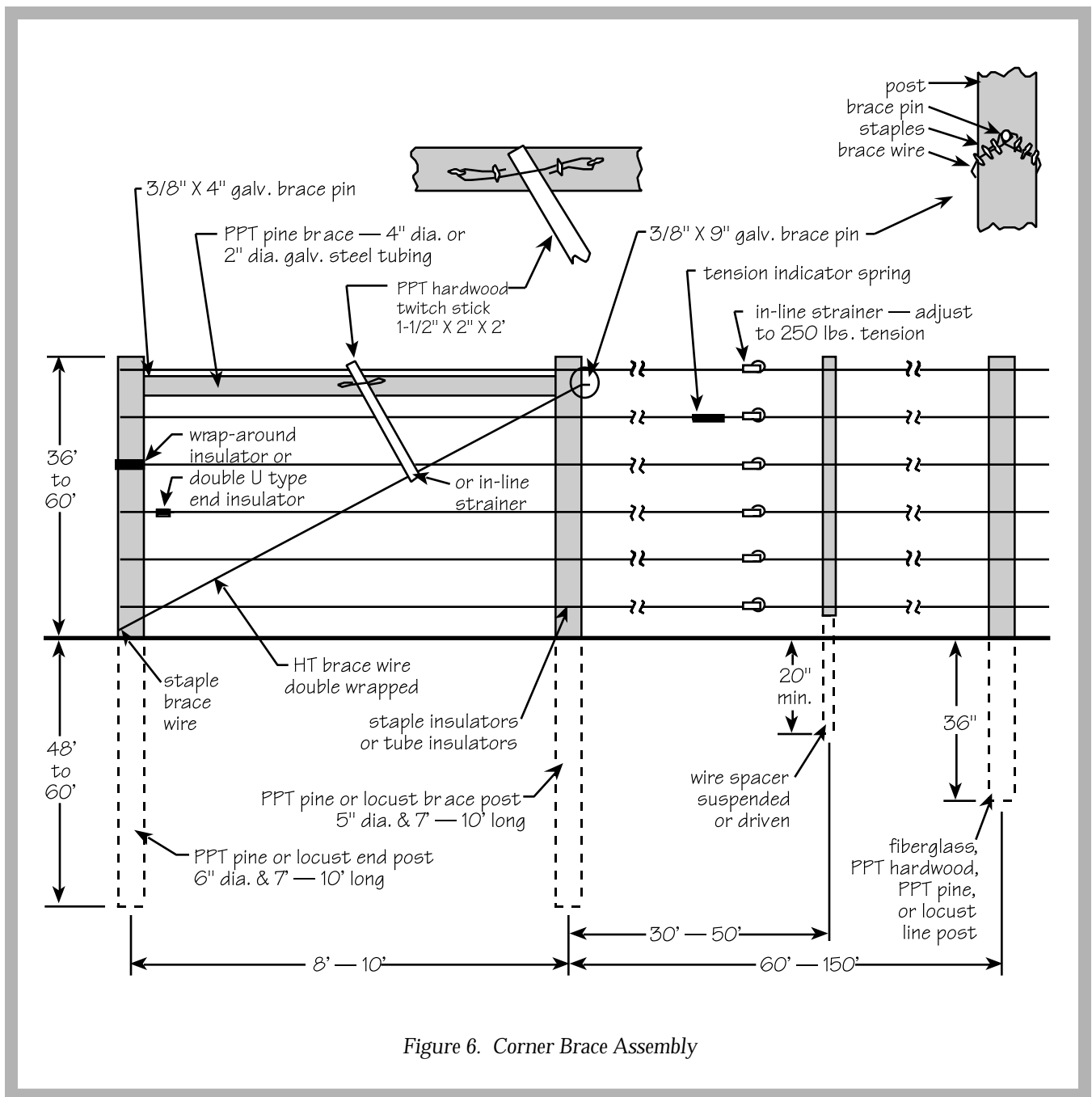

Figure 6. Corner Brace Assembly

need leveling or more posts and tie downs, and possibly more maintenance in the future.

In some situations it is advisable to level the area first. Where this is done, re-grass the area to prevent erosion and/or weed growth. Animals standing on grass get a greater electrical shock than when standing on bare soil.

### Corner, End and Line Brace Assemblies

Corner-post and end-post assemblies are the backbone of the fence. A properly tensioned high-tensile fence puts a tremendous pull on these

assemblies. Both corner and end assemblies must be strong enough to withstand this force. The key is to build them right and put them in deep. Some producers have literally ripped their corner- and/or end-assemblies out of the ground while tightening the wires because the posts were set in the ground too shallow (Figure 6).

A corner post will need a brace assembly for each fence leading to it. When the fence is more than 200 feet long, it is best to use a double span assembly (Figure 7). The double span assembly is more than twice as strong as a single span. Set the

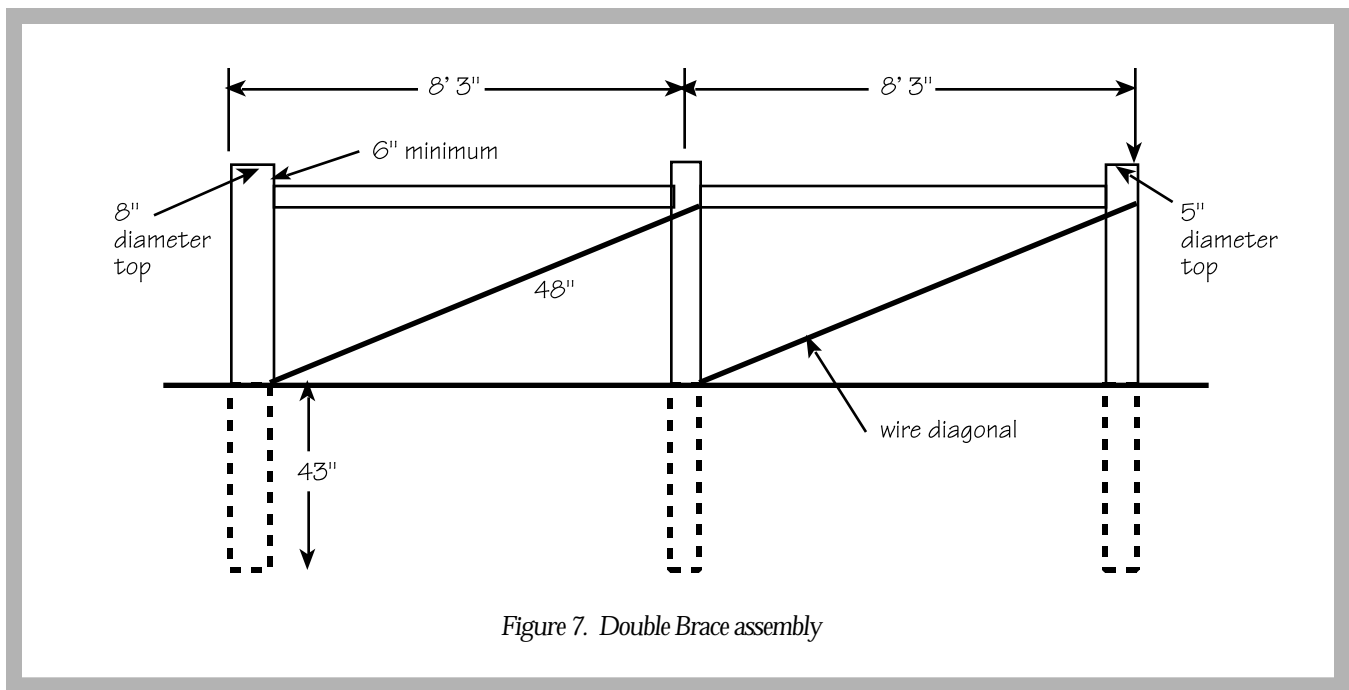

Figure 7. Double Brace assembly

corner posts leaning back from the direction of the fence approximately five degrees. Brace wire should pull in the opposite direction than the fence is pulling.

When a fence is more than 650 feet between corner posts, use braced line post assemblies every 650 feet in the fence line. A braced line assembly is the same as a single span braced corner, except a second diagonal brace wire is used to take fence pull in the opposite direction. In some situations, such as where adequate post depth cannot be achieved, additional bracing may be required to maintain tension.

### Setting Fence Posts

Wooden fence posts can be driven in the ground or tamped into place. A driven post is 1.7 times as strong as a tamped post. Posts larger than 4 inches may need to be sharpened to a dull point or driven in an auger-drilled pilot hole when using a post driver. For uniform depth, mark the digging tool or a steel post to the desired depth. You can drive the post in the ground with a manual post-hole driver or a tractor type.

Another method for setting posts is to dig the hole larger than the post diameter, place the post in the hole and then repack the soil around it. Center the post in the hole before tamping. This makes tamping easier and gives the tightest soil-pack around the post. Replace small amounts of soil and tamp. Plumb the post while tamping to

see that it is in proper alignment.

The distance between line posts depends primarily on topography. On extremely flat land, line posts are generally spaced from 10 to 16 feet apart if the fence is not electrified, to as much as 150 feet apart for an electrified fence. Battens or spacers are installed in all dips or at a maximum of 30 feet apart for five strands and 50 feet for two to three strands. Line posts are moved closer and closer together as the terrain goes from flat to hilly.

### Running Wire

High-tensile wire is packaged in various size coils. Wires can be run from the coil one wire at a time using a payout spinner, or several at a time using a multi-wire fencer. When walking from the far corner post to the first one, make sure the wires are in a straight line. If the fence is on flat land this is easy, but if it is over gently rolling terrain, the wire can be straightened by lifting it and letting it drop on its own until it falls onto the same position. Where the fence line is on very uneven ground, getting the first wire straight is not so easy and may have to be done by driving in two pegs or sighting posts where each can be seen at the same time as the corner posts. Then sight over the guide posts and move them until they are all in line with the two end posts.

Run the bottom wire out first and tension it sufficiently as a guide for setting line posts. Wires

are secured to corner, end or gate posts with crimping sleeves or appropriate knots. Secure the bottom wire to each line post as it is driven to assist in determining the next post position.

Eight to 10 wires are recommended for non-electric high-tensile wire fences for cattle. Three to five wires are all that are necessary if the fence

is electrified. String the wires on the inside of the posts or on the outside of curves. Drive staples slightly off the vertical so they straddle the wood grain, as shown in Figure 8. When driving staples into posts, rotate the staples around 25 degrees from the flat surface of the point. Rotating spreads the legs, which helps give the staple greater holding

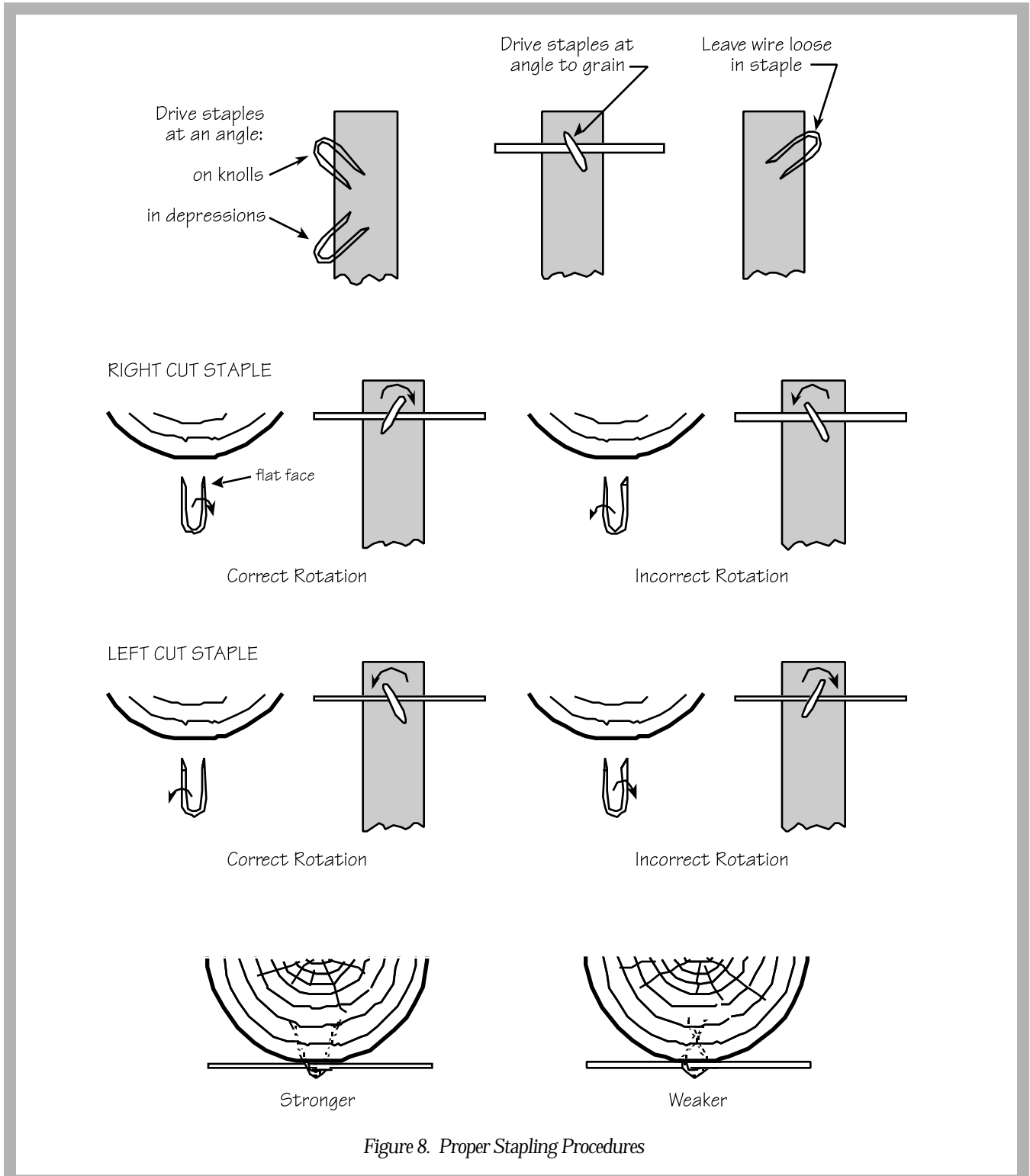

power. Drive staples at an upward angle into posts in dips, and at downward angles into posts on rises. **Do not drive staples in too deeply.** The wire must be allowed to slide through the staples for adjusting tension. All energized wires must be insulated from posts and battens. If using the fence for predator control, it is important to alternate at least two or three “hot” wires with the remaining wires. These are used as a ground so predators receive a severe shock when attempting to squeeze between the hot and ground wires. Always plainly label electric fences to avoid danger to people.

### Tensioning Wire

As a safety precaution, always wear heavy gloves and eye protection when tensioning wire. Tension each wire to 200 pounds with a ratchet in-line strainer or tightener. Excessive tension not only damages the wire but may lift the fence out of the ground in gullies. The ratchet also permits seasonal adjustment for temperature changes, if necessary. Use a tension indicator spring to obtain the proper wire tension on each wire (Figure 9). Then, tighten all other wires by feel to match the tension on the wire with a spring. On runs shorter than 600 feet, the in-line strainer and tension spring can be located anywhere along the fence, usually near one of the ends. However, on long runs, it is recommended to place them in the center of the fence so that the wire pulls in from both sides. On long straight runs of more than 600 feet, place them at the friction center which is at the center point between the two corners or ends. On long runs with a straight section on one end and several bends on the other, the friction center will be in the bends section rather than in the straight section.

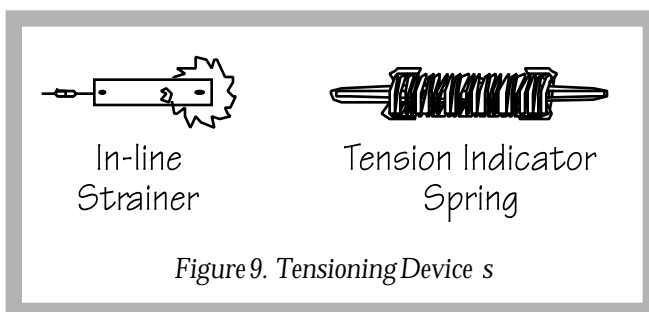

## Repair and Maintenance

Properly-built and well-maintained fences will give you the most trouble-free service for your money. A maintenance program is a must. Include some of the following tips in your regular maintenance program:

- Keep the fence wires properly stretched. Fences will naturally loosen over time or with seasonal changes. If tighteners are placed in the fence, check at least twice per year. Other fences may be tightened by resetting or by putting several small kinks or creases in the wire using pliers, a hammer or special tool designed for this purpose. Splice broken wires when necessary.
- Repair or replace anchor post assemblies whenever they show signs of weakness. Refasten loose wires to posts.
- Old woven wire and barbed wire fences which have deteriorated enough to need replacement can be restored to last for many more years by running an electrified wire on one or both sides of the fence through offset brackets attached to the old fence. These offset brackets are made of galvanized high-tensile wire and are easily attached to the existing fence. They should be attached at two-thirds the height of the animals to be controlled, next to posts where they will be held more securely than sagging on old wires in the center between two posts.
- Use herbicides or manual clearing to keep weeds and vines from covering fences. Grass and weeds touching the wire can ground it and make the fence ineffective for controlling livestock. An inexpensive fence tester should be secured and used frequently to assure proper functioning of the fence.
- A carpenter’s apron is very handy for holding nails, staples and small tools, and a good pair of gloves prevents hand injury and helps in gripping wire. Specialized fencing pliers are an excellent investment for anyone who builds or maintains fences.

## **References**

- Planning Fences. 1980. American Association of Vocational Instruction Materials.
- Kay, F. W. 1990. Fences for the Farm. University of Georgia Cooperative Extension Service Publication.
- 9th International Power Fence Manual. 1990. Gallagher Power Fence Inc.
- Selders, A. W., J. B. McAninch. 1987. High-Tensile Wire Fencing. NRAES-11. Northeast Regional Agricultural Engineering Service.

*PB1541 -2.5M-5/01(Rep) E12-4315-00-02-01*

Visit the Agricultural Extension Service Web site at:  
<http://www.utextension.utk.edu/>

# How to Hotwire a Goat

(How to Fence Your Goat)

By Yvonne Zweede-Tucker  
Smoke Ridge Cashmere  
Choteau, Montana

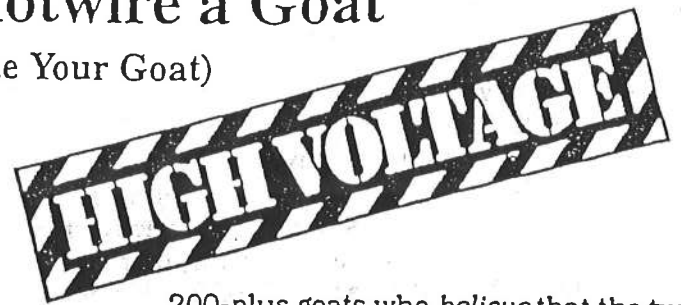

200-plus goats who *believe* that the two-wire electric fence is the edge of the universe, and that nothing worth having in life exists beyond it.

Electric fence is a mental barrier, not a physical one. Although not recommended with the highly-intelligent caprine, having the fences off occasionally does not immediately lead to jail breaks...provided that the fence *normally* works well, with 4,000 - 5,000 volts available on all wires. A very hungry goat, a goat in love, or a terrified animal will find its way through chain link fencing given enough time and inclination. Goats that are kept in decent body condition, rotated to fresh pastures when needed, given wide enough alleys and moved calmly through them, will respect electric fences and abide by the perimeters of the pastures as so defined.

Just as I like to visit other peoples' operations to see what nifty tricks, tools, or procedures they use, in order to possibly adapt some to work for us, let me share with you what we have found to be fastest, easiest, and most effective in electric fencing. Maybe it will save you some time or aggravation, or just give you new sources or alternative applications for fencing supplies.

My first goat property had a professionally installed, "Gallagher" eight steel wire high-tensile fence. The tension on the wires did in fact hold up a tree that fell on the fence in a windstorm, but also popped pin-lock insulators, pulled out or pulled off-center 5" wood posts, and didn't keep the bucks away from the does. (We've now progressed to half a mile separation, and are still not entirely at ease!)

The next farm had a combination of barbed wire and "field fence", or woven wire. We enhanced the established fencing with electric as needed to keep goats and guardian dogs from going through or getting stuck in the fences. Enhancing a barbed wire fence was done by adding a hotwire below the bottom barb, and also one between the bottom two barbed wires. As goats will attempt to push under a fence first, one good jolt in the nose tends to discourage them quite effectively.

Continued on next page



Yvonne Zweede-Tucker—she has hot wire, rebar and an overhead projector. She's ready to fence!

This anecdotal article will focus on a relatively new and as-yet not very common form of electric fencing, namely low-tensile aluminum wire fences. In our operation, having used and installed both high-tensile steel wire and the low-tensile aluminum wire, we prefer aluminum for ease of installation and maintenance, and effectiveness in holding our goats in.

Just as there is no one perfect type of goat for all operations, because each person's situation, financial realities and therefore breeding objectives vary, there is no one perfect fence that everyone could or would like to use for their herd(s). We regretfully loaded a big, beautiful, black, fine-fibered buck with excellent confirmation onto the meat truck when it became obvious that his lovely hindquarters easily propelled him cleanly over 52" rigid panel fences from a walk.

One doe selected herself out of the breeding herd when her fetish for the guardian dog's kibbles led her into the wrong pasture time and again...with both her lovely twin daughters hard on her heels! Without Mom to lead them astray, the twins stayed with the other



## Hot Goats

Continued from previous page

Therefore, an electric fence with a weak charge is a very bad way to introduce goats to a new area or new fence. If they learn that it tingles but that's all, you may as well not have strung the hotwire. An "offset" approximately 8-10" up from the ground and 6-8" in from the fenceline has been very effective for us in keeping goats both from going through the barbed-wire fence beyond it as well as from sticking their heads through woven wire fencing and getting stuck.

Our current (and hopefully final!) property was a blank slate. A perimeter fence of four-strand barbed wire existed, but no internal fences. A patchwork of different fields made up the rectangular property, and a number of those fields were and are still in a Crop Reserve Program (CRP), which means that domestic grazing animals are strictly forbidden to go into them. The prohibited fields have curving boundaries, there is an undulating irrigation ditch crossing the property, and a new driveway and house which the goats only got to visit one time (not planned!).

Budget considerations did not allow for woven wire fencing to be installed over the miles of fence that we needed to erect. Having brought all the "Combo" panels (1/4" rod panels 52" tall and 16' long) and steel posts from the last place, we re-established the "night pen" and sheds, water troughs and salt/mineral blocks in a centralized, easy to check on location. Then, one pasture at a time, we began to enclose areas that the goats were allowed to graze, with 16' alleys where needed.

Fences between allowed and prohibited areas are three strands, aluminum 14 gauge, all hot, with wires at approximately 10", 20", and 34". Divisions inside pastures are two wire, approximately 12" and 22". Posts are approximately 45' apart (15 long paces), with one steel t-post followed by one to four 4' rebars, and then another steel t-post, depending on how straight a line the fence is following (sharp curves need more steel posts, straight lines and gentle curves can use more rebar posts). Lean the posts out slightly against the curve - tightening the wire will bring them back in, and put the wire on the outside of the post going around a curve.

Gates are 8' to 16' wide, and currently predominately handles and wires between steel posts. We do want to have a few wooden posts pounded for both sides of high-traffic gates for solidity.

Our night pen is made of "combo" panels, 384' long by 64' wide, with 8 evenly-spaced sheds of 16' wide

by 8' deep by +/- 4' tall (plywood sides, tin roofs). Rubbermaid 50-gallon low-wall water troughs are portable and easy to clean, and by cutting small sections of the bottom of the panels out, the trough can service two pens at once. We can divide the 200 goats into 8 different breeding groups of 25, or more realistically, 3 groups of 50 with two buffer groups of 25 doelings (no buck) between each. Bucks in love, sharing fencelines, have proven detrimental to the lifespan of panel fences. During summer, when the herd nearly triples, there is adequate shed space for all to take cover from hail or windstorms.

Our objective is to continue to subdivide the pastures until we have between 28 and 30 paddocks between which we can rotate the goats. This summer the goats mined the property for thistles, brush, and wild roses, prompting some astonished local ranchers to ask us exactly what we had sprayed with...

These are all fences that have worked for us, based on what was in place already, using all-aluminum 14 gauge wire, t-posts and rebars, and flat-back plastic "tunnel" insulators (stapled onto wood posts, wired onto steel posts and rebars).

The following list of fencing supplies, prices and vendors is not meant to be exhaustive, cumulative, guaranteed, or an endorsement. It simply tells you where we bought our goods, and gives you an idea of relative prices.

Wire: Pure aluminum, 14 gauge, \$114 per mile, 12.5 gauge, \$165 per mile, from Twin Mountain Supply (800-527-0990) or in Belgrade Montana, Gallatin Farmers (406) 388-4808.

Insulators: "Flat-back", \$0.0375 each (that's less than 4 cents each), "Double-U" insulators serve as anchors, 60 cents each, both from Kencove (800) KEN-COVE (800-536-2683).

Handles: variety available, from \$1.19 to \$5.00 each (ours \$1.85 each)

Steel t-posts: Pacific, \$2.05 for 6' posts

Rebars: Pacific, approximately 50 cents for 4' lengths, 28 cents for 2'

Charger: Talk to Kencove, or any other reputable supplier that is familiar with aluminum wire, to determine the size and power of the charger that your op-

Continued on next page

**Hot Goats**

Continued from previous page

eration will need (how many miles of wire, how much impedance, how much pain-potential do the animals need for respect).

- 1) For: existing 4 or 5-strand barbed wire  
Add: an offset, 10" up, 8" out

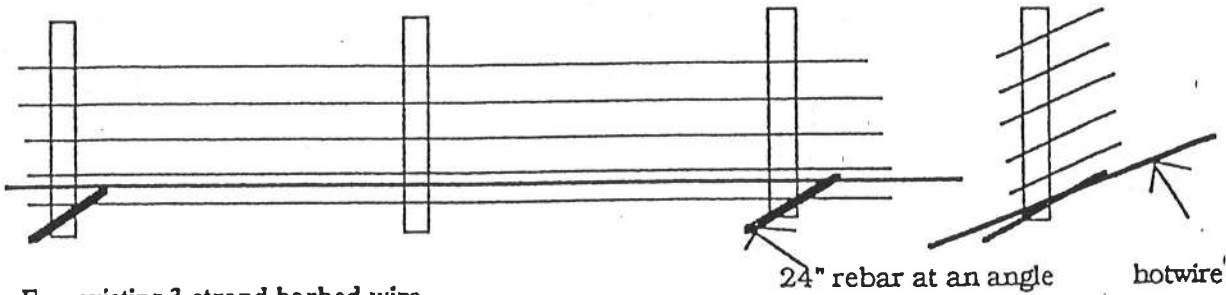

- 2) For: existing 3-strand barbed wire  
Add: two strands hotwire

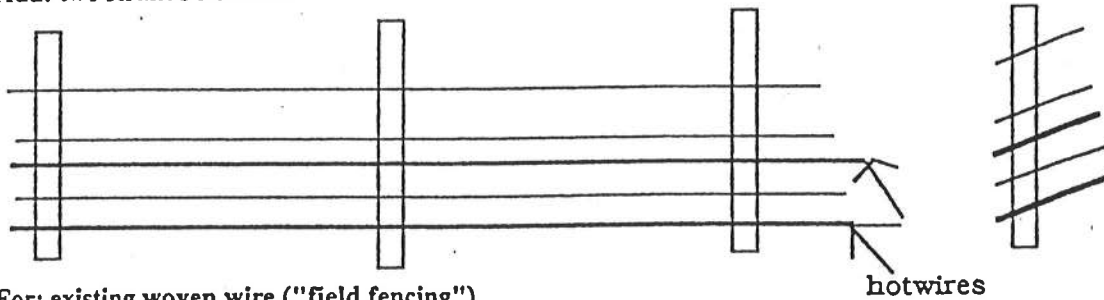

- 3) For: existing woven wire ("field fencing")  
Add: 1 or 2 hotwires

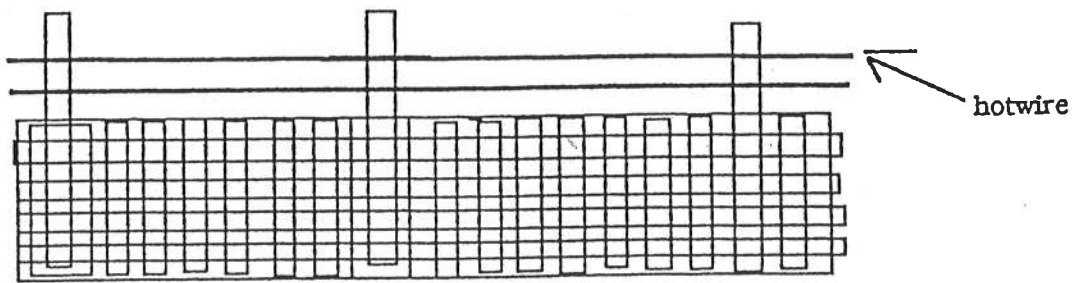

- 4) For: no current fencing on perimeter  
Add: hotwires at 10", 20", 34" height

- For: no current fencing on internal divisions  
Add: hotwires at 12" & 22"

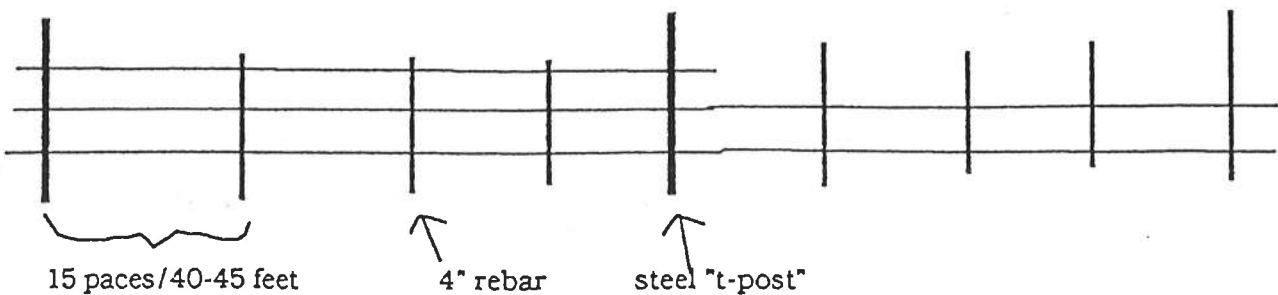

This fence works very well with aluminum low-tensile wire, but probably wouldn't with high-tensile, unless it was in a very straight line!

# Facilities

## Additional Resources

### Books

**Sheep Housing and Equipment Handbook** Hirning, Harvey J., Tim C. Faller, Karl J. Hoppe, Dan J. Nudell, and Gary E. Ricketts. 1994. MidWest Plan Service, Ames, IA. 90 p.

These plans are also useful for goats, and include a few plans specific to goats.

**The Dairy Practices Council Small Ruminant Guidelines** Guidelines for the Dairy Industry Relating to Sanitation and Milk Quality for Small Ruminant Operations.

The Dairy Practices Council  
51 East Front Street, Suite 2  
Keyport, NJ 07735  
732-264-2643  
[www.dairypc.org](http://www.dairypc.org)  
Set: \$70.00.

A set of 17 Guidelines relating to small ruminants; each may also be purchased separately. Very good technical information for commercial producers of dairy sheep and goats.

### Web sites

**Maryland Small Ruminant Page**  
[www.sheepandgoat.com](http://www.sheepandgoat.com)

**Langston University–E (Kika) de la Garza American Institute for Goat Research**  
[www2.luresext.edu/goats/index.htm](http://www2.luresext.edu/goats/index.htm)

**Housing Your Flock**  
[www.ece.neu.edu/groups/rcl/publications/sheepyards.pdf](http://www.ece.neu.edu/groups/rcl/publications/sheepyards.pdf)

# Marketing and Economics



In this section:

- *Alternative Meat Marketing*
- *Direct Marketing*
- *Evaluating a Rural Enterprise*
- *Keys to Success in Value-added Agriculture*
- *Adding Value to Farm Products: An Overview*
- *Value-added Dairy Options*
- *Direct Marketing Lamb to Niche and Ethnic Markets*
- *Additional Resources*



[www.attra.ncat.org](http://www.attra.ncat.org)

# ALTERNATIVE MEAT MARKETING

**LIVESTOCK TECHNICAL NOTE**

ATTRA is the national sustainable agriculture information center funded by the USDA's Rural Business -- Cooperative Service.

**ABSTRACT:** *This publication offers general information on alternative meat marketing. Topics include pitfalls to be aware of, production and processing, different types of direct marketing options, legal and regulatory considerations, and information on differentiating products through organic certification, natural and environmentally sound production, and targeting ethnic and religious markets. Information on production and marketing of meat products from specific species is also available from ATTRA (see Related ATTRA Materials) and from other sources (see Resources).*

**By Holly Born  
NCAT Agriculture Specialist  
May 2000**

## INTRODUCTION

Marketing is an important and challenging task for all farmers and livestock producers. Livestock production is high-value production, and not only is the final product often perishable or semi-perishable, but there are relatively narrow windows during which slaughter stock are at their market peak. In this respect, livestock production

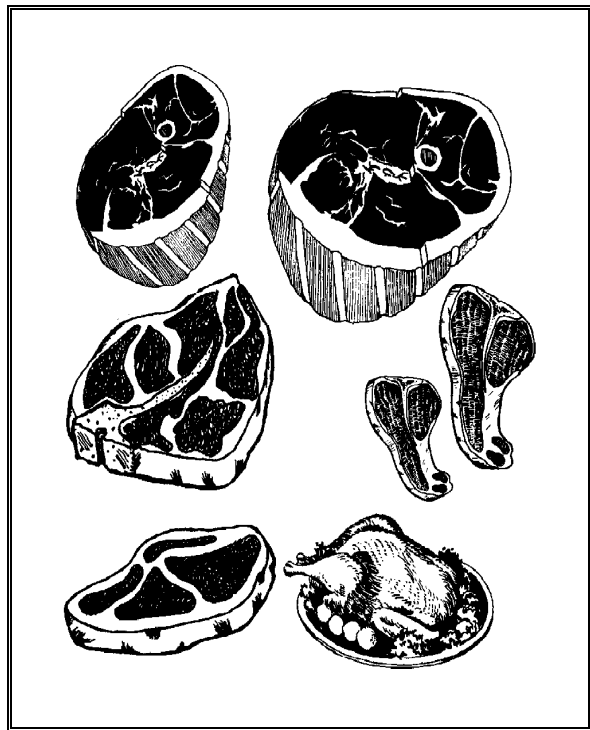

shares much with the fresh produce industry – the product has to be sold within a certain time, and the buyers know it.

Unlike the produce industry, however, much livestock production, especially that involving cattle, requires very long lead times that preclude rapid changes in plans. From the moment a producer decides to retain a heifer calf for breeding it will be roughly four years before her calf is on the consumer's plate. Such generally long lead times, coupled with the relatively perishable nature

CONTENTS	
Introduction.....	1
Pitfalls .....	3
Producing and Processing for Quality and Consistency .....	4
How To Get Started in Direct Marketing .....	8
Direct-To-Consumer Marketing.....	10
Restaurant and Institutional Food Service .....	11
Retail: Supermarkets, Grocery Stores, Natural Foods Stores .....	14
Cooperatives.....	15
Value-Added Products .....	16
Food Safety and Labeling Regulations.....	16
Differentiating Your Products .....	18
References.....	21
Resources .....	23



of many livestock products, underline the fundamental importance of developing an effective marketing plan for each livestock enterprise (1).

Faced with the increasing concentration of today's conventional market, in which livestock producers have less and less control over the prices they receive, producers need to take advantage of every opportunity for innovative marketing and adding of value. Alternative marketing can provide an opportunity to receive fairer prices for livestock or meat products than conventional channels offer.

Alternative meat marketing can be the backbone of the farm business, or a way to supplement income in times of low prices in conventional markets. Many farmers sell the majority of their livestock on the conventional market and direct-market a few head for extra cash. Others may not be livestock producers, but have some acreage that would be suitable for feeding out a few head for the local freezer market, for example.

Many small farmers find that diversification allows them to make maximum use of their land as well as to maximize their returns. For example, pasturing a few head of cattle and a herd of sheep or goats allows farmers to offer a mix of products while maximizing pasture resources. Small ruminants offer more efficient pasture utilization and conversion than cattle, and have different forage preferences. Swine and poultry may also play a role in the integrated farm. The shorter production cycle of poultry allows more continuous sales and more frequent income.

Offering poultry can serve to gain customers for the other meat enterprises. While few consumers are willing to commit to spending hundreds of dollars for a half side of beef, almost everyone can afford to try a whole chicken or a dozen eggs. Once they taste the difference, they'll be much more inclined to buy meat.

### **RELATED ATTRA MATERIALS:**

- \* Alternative Beef Marketing
- \* Alternative Marketing of Pork
- \* Bison Production and Marketing
- \* Sustainable Chicken Production and Marketing

Ultimately, the success of any meat or egg producer depends on marketing. Producers who want to "cut out the middleman" must be prepared to wear many hats. While margins are

### **Questions to Ask Yourself**

What market segments do you want to focus on? Why? What are the needs of each segment? What type of product(s) do you need to produce to meet the needs of each segment? Can you do this profitably?

For example, you may decide to focus on segments that care about health aspects of meat, because you think that there is a large potential customer base, because you want to produce in an environmentally friendly way while reducing production costs, and because you can sell at a premium. These segments may focus on low fat, non-medicated, and/or organic. Consider breed and methods of production: one segment might want more tender/fattier meat that is certified organic, another might prefer a grass-fed or very lean product. What types of cuts and sizes do these consumers want? Can you produce these while not losing money on less popular cuts? Do customers need education about aspects of your products, and if so, how can this be done? Where do consumers in these segments shop, and can you get your product to them? Or give them good reasons to come to you? For more information, request the ATTRA publications *Direct Marketing* and *Evaluating a Rural Enterprise*.

considered excessive by some, be aware that the middleman does earn a large share of the end price by performing a wide range of functions. Some of the functions you will be taking on include processing, packaging and labeling,

storage, transportation, and marketing. Marketing includes research, targeting markets, advertising, and going out and making the sale. This can be one of the most difficult aspects for producers to master. While it is relatively simple for a good producer to learn how to produce something different, marketing is an entirely different occupation. To succeed, you will need to learn the jargon of business and how to feel comfortable and confident when drumming up new business. You may want to contact your local university's college of business or small business development center for recommendations on good introductory materials to get you started.

## PITFALLS

As you'll read below, there are many decisions the marketer has to make. With each decision there is the opportunity to make mistakes. Some of these mistakes are fairly easy to resolve, such as changing the type of products you offer to better suit customer preferences. Some, however, can be costly. You need to be aware of what you as a producer can realistically hope to accomplish by direct marketing meat, and decide first and foremost whether what you can accomplish will meet your needs. Very few producers can meet all their financial needs in the first several years of direct marketing meat. Even when the market is there, doing your own marketing can take an incredible toll on your time, sanity, and family and personal life.

Many small producers find that when they begin direct marketing meat, it practically sells itself. Word of mouth and some minimal promotion let them sell out quickly. Encouraged by the great response, producers see what appears to be the answer to their farm problems and begin expanding production and investing in facilities and equipment. What they don't realize is that after getting beyond a certain number of sales a year, they may "hit the wall" of demand. In other words, the market for these higher-priced

specialty products is shallow: there are a limited number of people who are willing and able to buy. This turning point will come at different sales levels depending on the size of your community and the number of customers inclined to buy your products. The "easy" customers have all been located and supplied to their satisfaction, and the freezers begin to fill up.

Selling more products then becomes a true challenge. This is the point where the real marketing begins, as you have to target, educate, and persuade consumers and food industry people to try to buy your meats. Making the transition from selling a few head a year to full-time commercial meat marketing is extremely difficult, and the odds of success are low. You will need to carefully evaluate your goals and resources to decide whether you want to take that next step. Many producers have tried and failed. Beginning to doubt their own abilities, they get discouraged. A hidden key to many of the success stories you have heard is that the producers had some source of capital beyond farm income and bank loans. Often this capital comes from previous, non-agricultural jobs, a well-paid spouse, or an inheritance. The point is that unless you are fortunate enough to be in this position, your best bet is to start small and be patient.

The Tallgrass Prairie Producers' Cooperative found how difficult marketing can be. Pete Ferrell, a cooperative member, says:

"The wholesale meat business is totally ruthless and cut throat. The minimum volume for a successful wholesale business is pretty high. We figure our breakeven is around 30 head a month. You are going to need a lot more capital than you think and you need to start out with experienced management. We made a lot of costly mistakes early on because we didn't know what we were doing...In retrospect, we should have hired a consultant who understood the natural meat trade. We have learned it the hard and expensive way — by doing it wrong first (2)."

Annie Wilson, another Tallgrass member, relates some of the co-op's experiences (3). She says that

members thought that direct marketing would require less capital and lower risk than conventional marketing, but found that it was still very risky. Consumers expect to pay less, since they are buying direct and usually in bulk. A large number of small sales mean much more time is required for order processing and delivery to generate the same amount of sales dollars. Given this, she questions whether it is truly possible to “beat the middleman.”

Profitability, Wilson says, means access to volume markets, cost-effective operations, and professional management. The latter is required to make the first two possible. There is a critical mass of supply needed to get into the volume markets and to run a cost-efficient operation. There is also the question of capital needs, and the need to gain enough expertise to develop a business plan and manage the business. Business planning and management was much harder and took more time than the coop had expected. At the minimum, says Wilson, gross margins and cash flow need to be evaluated monthly. Cash flow in particular makes or breaks the business. As is true in any enterprise, cash shortfalls at critical times can put even a very profitable business out of business. Wilson, like many producers, found that it was inefficient to take time from being an excellent producer to be even an average marketer. She thinks that “alternative” marketing shouldn’t always mean direct marketing. She encourages producers to consider “new generation” cooperative marketing through viable-scale, functionally integrated, professionally managed, producer-owned enterprises.

## PRODUCING AND PROCESSING FOR QUALITY AND CONSISTENCY

Regardless of product or marketing outlet, developing a sales base depends on being able to deliver a consistent product. While there may be more tolerance for slight inconsistencies among consumers who have developed a relationship with the producer, consistency is cited over and over as a key factor in sales to restaurants, stores,

and other non-consumer direct outlets. Consistent quality begins at the production level with selection of the right breeds of livestock for your markets.

For example, a grass-finished beef producer who is targeting health-conscious consumers and plans to market beef for the freezer will need to avoid large-frame cattle bred for the feedlot, as these breeds may not do well on pasture. Additionally, the smaller breeds of cattle offer smaller cuts of meat, which are more appealing to today’s smaller families with limited freezer space. On the other hand, a producer targeting the “gourmet” niches may need breeds that put on more fat for the tenderness and mouth-feel that this segment craves. In addition to breed selection, careful management is required to avoid variations in flavor caused by differences in forage, age at slaughter, and so on.

You may need to change your production methods to better accommodate marketing. For example, some farmers combine baby beef marketing with innovative herd management: cows are bred to calve in the late summer, and the calves weaned when they go out to pasture the following spring. The young stock are large enough to profit from good pasture, but are slaughtered before having to be carried over another winter. One disadvantage to marketing baby beef is that the price per pound may need to be somewhat higher to generate the same gross income per animal.

- **Processing**

Producing a quality animal is only the first step in producing quality meat products. The ability to offer a safe and attractively packaged product is a basic requirement for successful marketing. You would be well advised to learn as much as you can about slaughtering, cutting, aging, packaging, and so on. Learning about cuts, dressing percentages, and weights is crucial. This information is available from most university meat science textbooks or departments. While basic information is available from textbooks, it can be difficult to relate the diagram in the book to the actual carcass at the processing facility. If at



all possible, you should try to get some hands-on experience. Some universities offer workshops and short courses at their teaching facilities.

- **New Rules**

In July 1996, the USDA-Food Safety and Inspection Service (FSIS) announced implementation of new rules for improving the safety of meat and poultry. A major component of the final rule is the Pathogen Reduction/Hazard Analysis and Critical Control Points (HACCP) system, a science-based strategy for protecting public health. Many small processing plants are uncertain about their future due to the implementation of HACCP. Before making long-term marketing plans, you may want to check with potential processors to make sure that they will be able to continue operating under HACCP. For more information on USDA regulations for processing meat, milk, or egg products, call the USDA Technical Information Service in Omaha, Nebraska, at (402) 221-7400.

There are basically three levels of inspection: federal, state, and uninspected or custom-slaughter plants. Meat processed at a federally inspected plant may be sold in any state, while meat from state-inspected plants can usually only be sold in-state, and is subject to state regulations. Uninspected plants usually process for the owners' use, and meat processed in these plants must be stamped "Not For Sale". Your marketing decisions are likely to be based on your processing arrangements. For example, many stores and restaurants demand federally inspected meats. Liability insurers may also require federal inspection.

However, small producers are finding that industry consolidation hits home when they begin looking for a suitable processing facility. Federally inspected processing plants that are willing to keep your meat separate, or even to take on small numbers of animals, are increasingly difficult to find. Larger plants may not be equipped to do custom butchering for smaller producers. Those that are willing to custom process may not meet your standards of cleanliness and integrity. What are your options?

You may be able to pool your livestock with other producers' in order to meet the volume that some processors demand. Or, you may be able to use university meat science department facilities. If federal inspection is not possible, your marketing decisions will have to be based on using either a state-inspected facility or making arrangements with custom processors. The marketing options discussed below give some general guidance as to which markets require which types of processing.

A bill to allow state-inspected meats to be sold interstate and internationally was introduced by South Dakota Senator Thomas Daschle in late 1999 and referred to the Senate Agriculture Committee. There is some controversy regarding whether to wait to make this bill a law until HACCP regulations are fully implemented, or to pass the bill as soon as possible. Ohio Agriculture Department director Fred Dailey, who spearheaded the move to change regulations, says that this legislation will not only increase interstate marketing options but is also likely to increase in-state meat sales. Distributors and retailers will no longer have to segregate federal and state-inspected meat and poultry products in their warehouses and delivery trucks, for instance. Dailey also expects this action to improve competition by providing livestock producers with more markets for their animals (4). For current information on the status of this bill, check "Bill Summary and Status" for the 106<sup>th</sup> Congress for Bill "S. 1988" at: <http://thomas.loc.gov/home/thomas.html>.

If you would like to express your opinion about this bill, contact information for all Senate and House members by zip code is available at: <http://www.congress.org>.

When selecting a processor, look for facilities that offer the level of inspection you desire and that are clean. Bacterial build-up is immediately evident to the nose. The processor should be able to package with Cryovac™ plastic film (see Packaging, below). When you find a good processor, it will be essential to develop a strong and mutually beneficial relationship. Some questions to ask prospective processors include: In addition to their certification level, has the processor had any experience in working with

direct-market/alternative-market producers? Has this experience been successful? Is the processor willing to work with your special needs? Is the processor interested in establishing a long-term business relationship? Producers need to "think like the butcher thinks" and be able to talk their language. You should be there while the butcher cuts and pay attention to the process. Keep instructions as simple and straightforward as possible. Some producers pay higher prices during busy processing times to ensure that their livestock get priority.

Aging of beef is recommended for tenderness and taste (pork and lamb are not aged). Ideally, the beef should hang for at least two weeks, preferably three. Pay the processor a bit more if needed to ensure enough aging time. Producers should insist on quick-freezing the meat no matter what packaging method is used. Although home freezers are designed to maintain previously frozen products, they can lower the final quality of fresh meat because they are not designed to freeze large amounts of meat at one time. Disposing of offal can be a major challenge for the processor. Be prepared to pay more or negotiate some other concession if the processor will perform this service. Finally, remember that the processor benefits too (from use of your trim, for example), so being aware of this can help you negotiate a win-win outcome.

- **Packaging**

All packaging should be done with airtight, high quality freezer paper or Cryovac™. Be aware that customers, especially first-time buyers, may want to buy meat that is packaged like the meat they see in the store, advises Jerry Jost of the Kansas Rural Center (5). This means using Cryovac™ packaging for "everything except soup bones", offering smaller portion sizes, not confusing carcass weights, etc. Jost

also recommends giving bulk customers the option of paper or Cryovac™. Vacuum packing meat with a Cryovac™ machine is perhaps the best method of packaging meat. The vacuum-sealed meat is not exposed to air and does not suffer from freezer burn. However, this will add about ten cents a pound extra to costs.

Each package should be marked with the name of the cut and the date packaged. It may be possible to provide the slaughterhouse with a stamp containing the necessary farm information, in addition to the required "NOT FOR SALE" wording required by law when the product is not federally inspected.

- **Types of product to offer**

The complexity of balancing purchases of different cuts among multiple buyers is a challenge that most producers, especially beginning marketers, may not want to take on. Small-volume producers primarily market whole, half or quarter animals so they do not have to find alternative uses for slower-moving cuts. This is the easiest since there is little inventory to carry and no storage hassles or costs, as well as no losses from unsold fresh product. For smaller livestock, this may be the best option.

However, many beef farmers begin by marketing sides of beef, or even whole animals; in most cases they discover that sides simply involve too much meat for the average family. The consumer has to pay too much money up front, and the meat takes too long to consume. Not only does

### YIELD INFORMATION

These are some very general guidelines to help estimate meat yields from the Sustainable Farming Association's Locally Produced Meat Fact Sheet Series (see "How to talk to customers" below for more information). Weights are in pounds.

	<u>Beef</u>	<u>Pork</u>	<u>Lamb</u>	
Live weight, whole animal		1000	250	95
Hanging weight (after slaughter)		682	175	40
Total meat yield after processing		550	165	33

*So, a half beef will yield about 200 pounds of meat; a quarter about 100 pounds.*

quality suffer after many months in the freezer, but the consumer is likely not to buy a side every year. Such start-and-stop marketing is often difficult to manage.

One common response to the problem has been to sell quarters rather than sides, but most preferred cuts are at the rear end of the animal, leaving the farmer to seek additional markets for shoulders and such. One response has been to sell "split halves" containing cuts from both front and hind quarters. Another response has been to slaughter short-keeps (700-850 lb. live) as "baby beef." Baby beef is not only tender without having a fatty finish to it, but there is simply less meat on a side, bringing the product more into line with current eating trends (1).

Other farmers have focused on the box market, providing a selected combination of cuts to particular market segments; such meat is often sold through catalogs and usually shipped via postal or courier service (with a block of dry ice to keep it frozen). Still others deliver boxes of beef directly to consumers in regional centers.

Pork, lamb, goat, bison, rabbit, and other specialty meats present even greater marketing challenges than beef and poultry. The meat being marketed is less popular, less well known and/or more expensive than beef and poultry. Most of these meats are sold in relationship, ethnic, or niche markets, and while the profits are often good, the markets are not particularly deep. A common characteristic of markets lacking depth is that there is little room for expansion, and even a modest amount of competition can erode profits severely.

Producers of specialty meats will need to be even more careful than beef and poultry producers in their work of planning and developing markets. Profitability can evaporate in a hurry if a producer goes to the extra effort and expense of bringing a specialty meat onto the market, particularly certified organic meat, only to find that there is no demand for the product at a price the producer can live with.

## • Pricing

Your first step will be to figure out what prices you will need, for a projected sales level, to at least cover your costs (break-even) or to achieve your desired profit margin. Missouri producer David Schafer provided an example of gross margin analysis in *Marketing Grass-Fed Beef* (5), which is adapted here to show how to arrive at a reasonable price estimate. Example: Start with "Purchases", which is either the price you originally paid for the animal or the price that you would have received for it at a given point in time. Say that you paid \$1/pound for a 750-pound steer, or \$750. Your Cost of Sales for this animal would then also be \$750 (this ignores livestock inventories since we are only considering a single animal here). Gross Product is thus zero.

**Sales = Gross Income**

**Purchases = Cost of Sales**

**Gross Product = Gross Income-Cost of Sales**

**Total Direct Costs =**

Processing + Marketing + Feed + Freight + Other Costs

**Gross Margin = Gross Product-Direct Costs**

**Percent Return = Gross Margin/Cost of Sales+Direct Costs**

Next, figure direct costs. Say the steer dresses out at 500 pounds of usable meat. Schafer likes to add 25 cents a pound for marketing costs, or \$125. Assume that processing will cost \$100, that feed (or what you could have gotten for renting pasture over the animal's growth period) is \$50, freight is \$50, and interest is 10% of \$750 or \$75. Total direct costs are \$400.

Schafer shoots for at least a 30% return. So,  $0.3 = \text{Gross Margin} / (\$750 + \$400)$  and the Gross Margin is \$345. Thus, Gross Product equals \$745 ( $\$345 + \$400$ ) and Gross Income equals \$1495 ( $\$745 + \$750$ ). Since inventory is ignored, Sales will also be \$1495. So, to make a 30% return on this animal, you would need to charge \$1495 for 500 pounds of meat, or an average of \$2.99 a pound. While rough, this analysis gives a base from which to calculate prices for simple or split halves, quarters, and individual cuts.

Now that you know the kind of price and sales ranges you need, you will need to evaluate your target market(s) to determine whether the market can meet your needs. For example, you may find that your profit goals could be met by a range from selling 100 pounds of steak for \$5/pound, or 10 pounds for \$50/pound. Market research is probably going to be necessary in order to determine whether you want to go after the \$5 or \$50 consumer, or both. You may be able to get assistance in setting prices and similar issues from Extension or the agricultural economics department at your local land-grant university.

## HOW TO GET STARTED IN DIRECT MARKETING

The strength of *relationship marketing* lies in first selling yourself, then selling your product. Relationship marketing is a powerful and effective means not only to build on positive consumer perceptions; it is a wonderful opportunity to educate consumers about the joys and challenges of farming. As educated consumers tend to be loyal customers, the advantages of this type of extra marketing effort are apparent. Yet it is also clear that the overall market needs both relationship marketing and wider distribution systems. Farmers may choose one or the other, or both.

Direct involvement is not for everyone, on either the consumers' or the producers' end of the equation. For the producer, direct marketing means deferring to customers and being responsive to their needs. It is crucial that the producer evaluate his or her own attitude before going into direct marketing. It won't work for some people, and they should be aware of that and concentrate on developing alternative markets that allow higher profits, such as selling direct to store or institutional buyers.

Allan Nation, writing in the *Stockman Grass Farmer* (6) recommends that you produce first for yourself, then for family & friends. If they don't ask for more, you're not ready to market. You need to find out why they didn't like the meat. Then you'll have to figure out what you need to do to produce the product that people want. This

sounds slow but in reality is faster and costs much less than the more typical way of jumping in and trying to learn as you go. Many start-ups fail because people aren't emotionally prepared for how difficult a business start-up really is. It takes time, persistence, and some source of income to live on while the business gets established. Since the customer base is very small for new businesses, total customer satisfaction from the very beginning is crucial to survival. For more information on direct marketing, please request the ATTRA publication *Direct Marketing*.

### • How can you find customers?

If you follow Nation's advice, your first customers will find you by word of mouth. Other ways to begin building a customer base include building relationships not only with consumers but also with private and government agencies, organizations, and businesses. Preparing attractive, interesting, informational materials about your family, your farm, and your products is a good place to start. Sampling is recommended over and over by producers as the best way to generate sales: "One taste is worth a thousand words." Your expertise as a sustainable farmer offers many opportunities for public education, and incidentally, opportunities for publicity.

A good way to begin getting your name out there is to write articles about topics that are interesting, newsworthy, and relate to your operation in some way. Newsletters, bulletins, and special-interest magazines are always in need of material. Newsletters from your farm or cooperative that link producers and consumers, both paper and on the Web, are another idea. Further possibilities include contests, which provide consumer names and addresses for targeted promotions, and partnering with state or county tourism associations. Media exposure generates mixed results. Some farmers have found that it greatly increases sales, others that it isn't very effective.

Successful direct marketers recommend giving presentations to community, church, and other groups about your operation and products. Offer to give talks that relate the issues of interest to

your operation. The local Sierra Club may be very interested in how your sustainable operation has preserved wildlife habitat, for instance, and members may want to support you. Schools and universities offer marketing opportunities, as well. Give talks to student classes and send the kids home with your brochures and a coupon or sample for their parents. Universities can be good places to begin identifying niche markets, since there are usually ethnic, religious, or special-interest (such as environmental concerns) student groups on campus.

Producers have found success from in-store cooking demonstrations with free samples. Demonstrations also offer the chance to bring in producers to connect with consumers so that producers can learn about what consumers want, and consumers can learn more about family farms and the rural life. Producers can invite consumer groups, foodservice buyers, and retail meat managers to tour their farms and processing facilities.

Exhibiting and selling products at local special events and giving tastings and demonstrations at farmers' markets helps many producers find customers. State fairs and other festivals require a lot of product that can be made available quickly to a large group of people who are in a hurry. Running a food booth also requires lots of advance preparation and possibly extra labor. Regulatory issues become more complex if you offer prepared foods such as burgers or sandwiches. However, it can be a great way to generate a lot of publicity and customers throughout the year.

Advertising in local newspapers and the like also produces mixed results. It is better to target your audience. For example, church newsletters and signs in appropriate stores such as health foods stores that are sympathetic to local producers can be good places to advertise. Since today most small farmers (and/or their spouses) have an off-farm job, the workplace offers marketing opportunities as well. Many producers have found their first customers to be co-workers.

Alternative marketing strategies require consumer education. Collect market research and apply for grants like SARE funds to do market research. Try working with universities to get student and professor help, and offering coupons or samples in return for completing surveys. Your enterprise could get free research and marketing assistance from the National Agricultural Marketing Association (NAMA). Interns can be found through the Association, and teachers and students are always looking for projects. For more information, contact:

NAMA  
11020 King Street, Suite 205  
Overland Park, KS 66210  
(913) 491-6500  
FAX: (913) 491-6502  
agrimktg@nama.org  
<http://www.nama.org>

#### • How to talk to potential customers

Some of the barriers to direct marketing include the perception that meat has to be bought in large quantities, the desire to see the meat and the farmers before purchasing, and questions about the safety of the meat. It's important that people know the kind and number of cuts they will get when they order a quarter or half of meat. For example, Snowball Beefmasters, of Snowball, Arkansas  
<<http://www.northark.com/snowballbeefmasters>> lets consumers know that a split half of beef totals "about 2 and 1/2 brown paper grocery sacks". Producer Martha Mewbourne (7) says that on orders under a quarter, people don't realize that they only get 3 steaks. She adds that boning cuts gives consumers the same amount of meat, but it's a much smaller total poundage, so consumers may think they are getting ripped off. Many customers ask for separate cuts to be available, but these are more difficult to price and smaller producers usually don't have enough volume to sustain this kind of marketing.

An excellent, comprehensive source of consumer-education material is the "Locally Produced Meat" fact sheet series from the Sustainable

Farming Association (SFA) of Northeast Minnesota. These fact sheets cover nearly every question that the consumer may have about buying local beef, pork, and lamb, including how to find a producer, how to order and arrange slaughtering and processing, details on meat and cut yields, costs, transport, storage, and cooking tips. You may want to use these fact sheets to model your own materials. For more information, contact:

SFA  
PO Box 307  
Carlton, MN 55718-0307  
(218) 727-1414  
sfa@skypoint.com

Ohio State Extension's "Buying Beef for the Freezer"

<<http://www.ag.ohio-state.edu/~ohioline/hyg-fact/5000/5400.html>> is also helpful.

## *What Kind of Direct Marketing?*

Many producers rely on a combination of markets. The most common outlets for direct marketing meat include the direct-to-consumer market; the restaurant and institutional foodservice market; and the retail market.

### **DIRECT-TO-CONSUMER MARKET**

- **Freezer meat market**

The freezer market is accessible to almost all producers who can locate suitable processing facilities. The number of animals producers can sell and the price they can charge depend on the population and demographics of the nearby area. Producers located near large metropolitan areas have a greater potential to market large numbers of animals to individual consumers than those in more remote areas. The freezer market is also a good way for farm families to add some extra cash to their income either by diverting a few animals from the conventional market or by feeding out a few head on unused pastureland, as long as quality can be maintained.

Any type of processing facilities can be used to access this market, including custom processing plants that are not federally or state inspected. In this case, the live animal is sold prior to slaughter. Rather than selling by liveweight, which doesn't account for variation in dressed-out percentages between animals, some producers often sell the animal for a token fee, such as \$1/head and then charge for processing based on carcass weight. An interesting option is the "Pay as They Grow" approach (8), which makes purchases more affordable for families while giving producers monthly income and a guaranteed market price. Here the customer contracts directly with the producers to raise their animals. The producer guarantees that their animal will produce at least a certain total weight of processed and packaged meat, for a predetermined price. The customer gives the producer a down payment and makes payments every month until the agreed upon price is reached and they get their meat.

The easiest option is to have people come out to your farm for meat pickup. However, you'll need to be fairly close to a moderate-to-large sized town or city to have a large enough customer base to support that kind of marketing. In addition, you will need adequate storage capacity to accommodate the meat until pickup and possibly a backup power source in case of power failure. Customers must be educated about the hours you will be open, or to make appointments. They will need a place to park and clearly marked directions to the building. Especially during holiday seasons, you will need to have popular cuts available in good supply. You may be able to notify customers when fresh meat will be available.

- **Farmers' markets**

Selling at farmers' markets is another option. However, not all markets allow meat sales, and those that do will require strict attention to health and cleanliness regulations. Market managers may not be familiar with local law so you may have to educate them yourself (see end section on legal aspects), and sampling (one of the most effective marketing tools) may not be allowed. If

you are going to market through a local farmers' market, you may want to coordinate with your health department and make sure that they are in agreement with state laws and regulations that govern the sales of meat products.

Some markets require producers to furnish their own generator and freezer if selling fresh or frozen meat. Some allow cooking at the market and the sale of cooked items, while others only allow processed and preserved meats such as dry sausage and jerky. While market rules differ, there are some general rules that apply to almost all markets. Frozen meat must be kept below zero degrees Fahrenheit (a plug-in chest freezer will usually be adequate).

Producers have found some keys to success at farmers' markets. Items sold at farmers' markets need to be fairly low-priced and small enough for people to carry easily. Displays are crucial. The Polyfoam company (900-323-7442/<http://www.polyfoam.com>) offers some products that producers recommend (9), including Styrofoam display boxes designed especially for frozen foods. Again, Cryovac™ packaging greatly increases sales appeal. Some producers buy used chest freezers and resell them at the market to customers who want to buy meat, but don't have the freezer space.

This is a very time-consuming option, but can be a great way to get started. Once you build a customer base, it may be possible to take orders and make deliveries at the market, which limits the amount of time you need to spend there. Send regular customers an order sheet with price, quantity, and pick-up dates listed. Customers can also sign up at the market or place orders by telephone or e-mail for market pick-up. Some markets do require regular attendance, so check with market managers before you begin attending the market less frequently.

- **Catering**

Other possibilities include catering meals such as hog roasts and barbecues for special events. In addition to consumers, your clients could include institutions such as schools or community and

church groups and community festivals and events. Again, getting into food service introduces new legal aspects since preparing and serving food is subject to a different series of regulations. While catering has worked well for some, it is also extremely time consuming (10).

- **Internet and mail-order**

Internet and catalog and other mail-order marketing outlets may represent a useful supplement to other outlets, but appear to be of limited value at present. One of the barriers to this kind of "remote marketing" is that packaging and shipping costs can as much as double the end price to the consumer. Websites can be useful in helping local buyers to locate producers in their area. Meat producers who joined to create the Prairiefare site (<http://www.prairiefare.com>), for instance, found that a website had real value as "kind of a combination business card and bulletin board", but that few sales directly traceable to the website were generated. For more information on the Prairiefare project contact:

LeeAnn Van Der Pol  
Sustainable Farming Association  
4075 110<sup>th</sup> Avenue NE  
Kerkhoven, MN 56252  
(380) 847-3432  
[vanderpol@prairiefare.com](mailto:vanderpol@prairiefare.com)

Some excellent market research has been conducted by the University of Maine Specialty Food and Drink on the Internet Project (<http://www.ume.maine.edu/~specfood/papers.html>). For more information, contact:

Dr. Greg White  
5782 Winslow Hall  
University of Maine  
Orono, ME 04469-5782  
(207) 581-3159  
[gwhite@maine.edu](mailto:gwhite@maine.edu)

## **RESTAURANT AND INSTITUTIONAL FOOD SERVICE**

The restaurant market is one in which producers sell primal or subprimal cuts of meat directly to individual restaurants. Producers selling to this

## Market Makers: Processors and Producer Partnerships

Mike and Rob Lorentz, of Lorentz Meats & Deli in Cannon Falls, MN, are custom meat processors and deli operators who realized that their small business depends on local family farmers for survival. So they are teaming up with producers for mutual benefit (11). The Lorentzes' experience in both processing and retailing through their deli have given them insight into what consumers want. Meanwhile, farmers in the area are looking to add value to their animals through marketing meat direct to consumers, but lack expertise. Thus Market Makers was born. The program requires farmers to pay a one-time fee of \$100 (refundable when the farmer processes with Lorentz). In return, they receive training on how to reach and keep customers, develop brochures, differentiate products, and cope with regulations. Program participants also get preferred treatment when scheduling processing.

The Lorentz brothers offer some advice to beginning marketers:

- State agriculture departments and processors can help guide you through red tape.
- You need to make a commitment to direct marketing and stick to it. Too many farmers drop their direct market customers when prices on the conventional market rise, only to find that these customers are gone forever when prices fall again.
- Don't let the going market price determine your prices! Your goals, costs, and types of product should set the price.
- Plan ahead and find out what breeds and cuts customers want. Try to sell as many animals before processing as you can. Don't wait until a few weeks before slaughter to begin marketing.

market must make arrangements for meat slaughter and cutting and the facilities must be inspected by the appropriate federal and/or state agencies. Care must be taken to prepare the meat according to the specifications of various restaurant chefs.

Individual producers often experience difficulty coordinating the complex management of production, processing, delivery, and sales system required to target the restaurant market. Since individual restaurants do not use large quantities of meat, access to a large number of restaurants and a mixture of different restaurant types is necessary for a producer to successfully target this market. Producers must be near a large metropolitan area with numerous restaurants in order to develop a direct marketing business based on restaurant sales. Access to a variety of restaurants will allow producers to market more of the animal, although the price received for the same cut will vary. Producers who sell directly to restaurants

usually establish a route and deliver directly to the restaurants once or twice a week year round.

Institutions, such as hospitals and nursing homes, school and university foodservice, and even prisons, offer more foodservice marketing options. Larry Jacobsen, Purchasing Manager of Allen Memorial Hospital in Waterloo, Iowa, explained how institutional buyers think and how to access these markets (12). Jacobsen found that costs didn't change overall from relying more heavily on locally produced foods, and that consumer reaction was extremely favorable.

When researching institutional markets, you'll need to find out what the vendor arrangements are. Jacobsen points out that most institutions (and many restaurants) have long-term contracts with food suppliers. These contracts offer many advantages for buyers: consistent pricing, fewer people to deal with, constant supply of consistent quality products, and the volume discounts



## Northwood Farms Beefs Up Restaurant Menus

Jim Goodman of Northwood Farms in Wisconsin raises Holstein dairy cows and steers without chemicals, hormones, or pesticides. When a restaurateur he knows mentioned that she was taking beef off the menu because she didn't have enough information about where it came from or how it was produced, Goodman saw an opportunity. He has been selling his beef to fine restaurants in the Madison area for several years. Goodman says that he likes the relationship aspects of direct marketing—knowing his buyers and making personal contact with them.

Goodman offers the following tips for producers who are interested in tapping into the restaurant trade (13, 14):

- Establishing a market can take years, so be patient.
- Remember that owners, chefs, and other staff are busy. Find out when “slow” times are and plan to make sales calls then. You'll need to establish contact and ordering policies. Misunderstandings are inevitable; so make sure you resolve them quickly.
- Be aware that the restaurant business is subject to frequent changes of staff and even ownership, and that the failure rate is high. Supplying restaurants means continually seeking out new accounts, sometimes even at the same restaurant if they hire a new chef.
- Menus, and demand for your meat, change often too. In general, however, restaurants want only the best cuts. Not only does this make it difficult to move the other cuts fast enough to be able to supply restaurants, but you may not have enough steaks for your other customers.

available from dealing with only a few suppliers. However, the prevalence of such contracts doesn't mean that you can't sell to institutions. Buyers have many ways of getting the products they want and the volume to enforce that with suppliers. You do need to understand the differences between institutional purchasing patterns. Schools and universities usually have more layers of bureaucracy, and thus are more difficult to access. Another obstacle is the increasing tendency of institutions to contract-out their food services to non-local chain operations, including fast food shops that have no interest in fresh, local produce.

Institutions may only require state-level inspected meats. Generally, food safety is not an issue for buyers since the suppliers are liable, but vacuum-packed fresh meats would be better received. An important thing to realize is that most food purchases are frozen, pre-cut, and even precooked. Purchasing locally may increase food preparation time for institutions. Jacobsen says that it's important to involve management in going local in order to get all staff cooperating.

To access these markets, Jacobsen says, you need to dedicate yourself to institutions and be ready to offer consistent supplies of quality products. Don't try to unload lower-quality product or start and stop marketing, or you'll lose business fast. Consider the size of the institution and the preferences of customers at each institution.

Hospitals, for instance, have different needs than university foodservice. A factor beyond your control is the personality and the commitment of buyers – persevere until you find someone who is interested. Institutions are volume buyers where “one call sells it all.” For pricing, buyers say what they have been paying, and negotiations can go from there. Loyalty is important. Keep your prices consistent so that buyers benefit when national prices rise.

Your best bet to land restaurant and institutional accounts is to visit chefs and buyers with an attractive sample offering. Your packet of informational materials will be useful here. You may want to include table tents with information about your farm and products and other

restaurant-oriented material as well. If the chef or buyer is agreeable, preparing a sample of meat will show if different cooking methods are required and demonstrate the quality. Emphasize the added value of your products. For example, most grass-fed meats' low fat content means that cooked product yield is higher. Jacobsen says that buyer farm tours were very helpful in showing the quality and cleanliness of the production and processing facilities and removed lingering doubts about trying local products. Offer to take buyers on tours of your farm and the processing plant you use.

## **RETAIL: SUPERMARKETS, GROCERY STORES, NATURAL FOODS STORES**

Retail food store buyers demand a consistent quality product, a year-round source of supply, and prices that are competitive with other sources of supply. Producers deciding to target retail food stores should also consider the quantity of meat needed and the marketing services that will need to be provided, such as prepackaging and delivery, and the cost of these services. Volume becomes critical when targeting an average supermarket. Small independent retailers with more upscale meat departments are probably your best opportunity. These kinds of stores want quality items that will make them stand out from the big chain stores.

Retailers may accept whole carcasses or demand precut, prepackaged meat, depending on whether or not they have a full-service meat department equipped to break whole carcasses. Fresh meat is what people want, says Annie Wilson (3), but it is beyond the reach of most producers to supply enough volume to offer fresh product unless the store will take whole carcasses. It is also difficult to have a constant supply of slaughter-ready stock, given the seasonal nature of most grazing-based production systems. Meat has a 10-14 day shelf life from the time of actual slaughter (not counting any aging time). As a result, locally grown and slaughtered meat will have a longer shelf life in the retailer's meat case than meat available from more traditional sources, which can be a great selling point if you are able to offer fresh meat.

Since retail food stores do not usually sign contracts with their suppliers, a sudden cancellation of orders can leave producers without a market. Another problem is that the price you need to make a profit may be, when coupled with retail markups, too high for most consumers. This is a major stumbling block for sustainable producers, whose production methods and especially small scale of production mean higher unit costs. Wilson's Tallgrass Prairie Co-op found that their Achilles' heel was processing costs (3). She points out that every penny of processing cost adds 2.7 cents to the retail price. Tallgrass was incurring costs of \$1 per pound to supply case-ready meat rather than the 30 to 50 cents possible with adequate volume to realize economies of scale. This meant that Tallgrass beef was out of range for all but a few rich consumers. Diana Endicott of the All Natural Beef Cooperative (15) also says that working independently means that it costs the co-op nearly double what it would cost to slaughter and process conventionally. Endicott targets only upscale supermarkets. Wilson favors targeting food buying clubs, which avoids too many margin markups and keeps prices affordable, while also avoiding some of the problems of marketing direct to individual consumers.

In addition to the cost and the perishability of fresh meats, consumer education can be a barrier to stocking local meat. Natural foods stores, in particular, find that "[f]or many of the hard-core faithful, 'meat' is a four-letter word (16)." Only 6% of natural products stores carried meats and only 4% carried organic meats in 1997 (17). Emerging health issues include irradiation and recalls of meat contaminated with bacteria, which can spur meat sales in natural foods stores. Producers need to look at it from the storeowners' point of view and work with storeowners to make it fly, share some of the burden of educating, etc. To place your product requires lots of visits, lots of free samples, and probably working with store managers/owners to develop campaigns based on promoting the local production aspects. Be aware that retail meat managers and counter employees can be crucial to the success or failure of products; bring samples and actively solicit their opinions and suggestions. Let them know that you will work with them.

## COOPERATIVES

Individual producers often experience difficulties in profitably achieving either the level of marketing services or the volume necessary to service the retail outlet. Therefore, a producer cooperative where several producers pool their animals and share fixed costs is often more appropriate when targeting the retail store market. Marketing through a cooperative can shift many of the time-consuming marketing activities away from the producer. The cooperative can engage in bargaining, transportation, grading, processing, distribution, and research and development for its members. A related option is the marketing club, a more informal farmers' group.

Cooperatives allow producers to get into the value-added sector of the marketplace while pooling knowledge, risks, and profits. Since the meat market is very competitive and it can be difficult to get shelf space in supermarkets, it can be impossible for smaller producers to compete with the high-volume large producers. Smaller producers will find more opportunity in developing local markets through cooperative marketing, which can ensure the quality and consistency that are vital to retail sales. Organizing farmers in a formal cooperative can be very challenging; however, a great deal of information and assistance for people interested in forming new cooperatives is available from the Cooperative Services (CS) branch of the USDA.

### All Natural Beef Cooperative Accesses Retail Markets

When Diana and Gary Endicott offered their drug- and hormone-free beef to meat managers at a local grocery, they found that demand for the meat exceeded what they could supply. So the Endicotts began locating other producers for what would grow into the All Natural Beef Cooperative.

Over five years or so, the co-op has established a profitable niche in a regional supermarket chain. Diana Endicott, who heads the co-op's marketing efforts, uses all the methods described above to attract and keep customers.

Endicott says that "a cooperative is like a family. You put together a diverse group of people and you have to respect each other's knowledge and opinions...Getting people together who have different skills and attributes really helps the business" (18). Some of Endicott's advice to producers interested in cooperatively accessing retail markets (15, 19):

- Building lasting relationships is vital for success. Loyal customers only make up about 30% of customers, but account for 90% of profits.
- Know what the retailer wants: a product that is unique, that the retailer's competition doesn't have, and product that will bring customers to the retailer's store. Your product should not replace products that the retailer already carries, but rather bring in *new* customers.
- Getting your product into the meat department means that you contact meat managers at the right time (when the store is looking for something new or different); that you are targeting the right place (upscale stores for a higher-priced product, for example); and that you are giving the right message—that you understand and believe in your product.
- Don't take rejection personally, but do your best to find out why the retailer doesn't want to carry your product. You may not yet be producing at the level of quality desired or the retailer may not be convinced that you can supply that quality consistently. Even an outstanding product can be hard to place, however. Remember that grocery department managers vary in their ability to make independent decisions. While an individual manager may want to stock your meat, he or she may be constrained by store buying policies, long-term contracts with conventional suppliers, and so on, especially in larger chain stores.

CS staff include cooperative development specialists who do everything from helping with initial feasibility studies through the development of bylaws and business plans, as well as training for cooperative directors. CS also provides technical assistance to existing cooperatives facing specific problems or challenges. Contact:

USDA Rural Development/ Cooperative Services  
Stop 3250  
Washington, D.C. 20250-3250  
(202) 720-7558  
FAX: (202)720-4641  
E-mail: [coopinfo@rurdev.usda.gov](mailto:coopinfo@rurdev.usda.gov)  
<http://www.rurdev.usda.gov/rbs/coops/cswwhat.htm>

## VALUE ADDED PRODUCTS

Ground meat will probably make up an important part of the operation. It is often necessary to sell a large proportion of the carcass as ground meat, which moves faster than cuts, in order to avoid inventory buildup. As marketers say, you need to sell it before you can smell it. Since ground meat is cheaper, you will need to evaluate your product mix to balance out lower returns with higher returns from the more popular cuts. Cull animals can be used exclusively for ground meat, which gives a superior product with more profit due to the low market prices for culls.

Cuts that are hard to move offer added value and sales when packaged as cubes for stews, stir fries, or kabobs. Ask the butcher to make square packages of ground and cubed meat, which pack and fit onto store shelves better. It may be possible to market bones to chefs, who appreciate the quality and high yield for soup stock, or to consumers who are interested in more gourmet cooking. You could include bones with soup stock instructions and recipes in your stew meat packages as a “freebie” to encourage sales.

Organ meats can be marketed to ethnic customers, in particular. Many ethnic dishes rely on organ meats and these can be difficult to find in mainstream stores. When researching the ethnic

markets that may be available to you, don't forget to find out whether there is demand for organ meats as well.

Producers are finding that further processed products can be quite profitable. Many small business and rural development centers and other organizations offer assistance in beginning food processing (for more information request the ATTRA publication *Adding Value to Farm Products: An Overview*). Some of the many options include sausage, hot dogs, and jerky. Be aware that meat products such as sausage that contain ingredients other than meat are subject to different laws (see following section for more information).

There is a growing demand for healthier, more natural pet foods. You may be able to market organ meats, ground meats, bones, and other low-end cuts as pet food. Even items such as pig's ears and hides can be made into dog chews. Getting into pet food manufacturing is too complicated a subject to cover in depth here. For more information, the Nebraska Food Processing Center (see **Resources**) can be very helpful. Other sources of information include food science departments at many universities. You may even be able to market composted offal. Compost marketing involves selling high volumes at low unit cost, which may be difficult for small producers to supply. Transportation costs will be considerable, as compost is a bulky, heavy product. Other ways to add value could include trading nutrient-rich compost to crop producers for products or services that you need, or offering compost as “thank-you” gifts to valued customers who enjoy gardening.

## FOOD SAFETY AND LABELING REGULATIONS

### • Regulatory Considerations

Before starting any marketing, consult local, county and state authorities on regulations governing the marketing of food products. Some rules that may apply include USDA inspection, health permits, licenses, sales taxes, weight and measurement requirements, sanitary requirements, zoning, and right-of-way regulations. Another important consideration is

waste disposal if you are slaughtering and processing the animals on-farm (see **Resources** for information on state environmental regulations).

Regulations vary depending on the type of product that you want to market. For example, selling frozen meat products directly to the public requires that the animals be butchered at a USDA-inspected facility; the meat must be weighed, wrapped and labeled in secure federally approved packages; and the meat must be kept hard-frozen at all times. In addition, regulations vary depending on where you wish to sell. Any interstate sales are subject to meeting USDA regulations. Sales within the state are regulated by state law. The county and regional industrial development authorities are a great and under-used resource that can help with these issues.

- **Product Liability**

With the increase in concern over food safety, the producer always has a small amount of product liability risk to deal with. Processing livestock increases this risk. The closer you get to the consumer in direct marketing, the higher the liability risk. For example, a ranch was asked to provide proof of \$2 million dollars of product liability insurance to be able to sell at a farmers' market (20). It is important to discuss this business consideration with your insurance carrier to see if farm liability insurance coverage is sufficient or if additional coverage is required.

The North American Farmer Direct Marketing Association (NAFDMA) offers its members liability and loss insurance specifically designed for direct-market farmers. Contact:

North American Farmers' Direct  
Marketing Association (NAFDMA)  
62 White Loaf Road  
Southampton, MA 01073  
(413) 529-0386 or (888) 884-9270  
<http://www.nafdma.com>

- **Label Laws**

There are specific laws regarding product labels that will require state and federal review prior to their use in advertising. Expediter services are

available. However, if you are going to be marketing single meat products (such as steaks or roasts) rather than products such as sausage that include other ingredients, it can be fairly easy to go through the labeling process yourself since a federal inspector at the plant can approve the label.

The Food Safety Inspection Service (FSIS) is the agency in USDA that has the responsibility for assuring that the labeling of meat and poultry products is truthful and not misleading. To label a product as being unique or superior by using words such as "natural" or organic, a producer must first contact the Labeling Review Branch of the USDA to make an "Animal Production Claim" for labeling the product. The producer then has to submit a label application, a sample label with the feature wishing to be claimed, and usually an Operational Protocol (OP). The OP describes how the product is produced and determines whether a producer can make the desired claim. Since each OP is based on the individual producer and the claim wishing to be made, the Labeling Review Branch (LRB) stresses the need for producers to contact their office for more information.

The Nutrition and Labeling Act (NLEA) of 1990 requires nutrition labeling for most foods and authorizes use of nutrient and FDA-approved health claims. While meat and poultry are exempted, if they are processed in such a way that they contain ingredients other than the meat, they become subject to meeting NLEA requirements. However, small businesses are exempted from these requirements. A "small" business is defined as having under 100 full-time-equivalent employees producing fewer than 100,000 units of any one product that will only be distributed in the U.S. Producers wishing to claim the small business exemption will have to notify the FDA that they meet the criteria unless they employ under 10 people and produce under 10,000 units a year. You may still need to include this information as a marketing tool or if your retailers request it, but be aware that if you do, you will lose your exemption. More information on the small business exemption can be found at <http://vm.cfsan.fda.gov/~dms/sbel.html>.

If you want to include the “lean” claim on the label, or make claims regarding your meat as a source of CAL or other nutrients, you will need to have it analyzed by a lab in order to back up your claim. Testing costs approximately \$30 for fat, \$135 for saturated fat, and \$112 for cholesterol (5). Some laboratories experienced in analyzing foods for NLEA compliance include:

Warren Analytic Laboratory  
650 “O” Street  
Greeley, CO 80632-0350  
(800) 945-6669  
<http://www.warrenlab.com>

TPC Labs  
Pillsbury Technology Center East  
737 Pelham Boulevard  
St. Paul, MN 55114  
(800) 400-2390  
<http://www.tpclabs.com>

Because the USDA has not yet defined the term “organic”, it may not be used by itself as a claim on the labeling of meat and poultry products. The FSIS will permit the use on the label of a meat or poultry product of a statement that the product has been “certified organic by (a certifying organization).” The certifying organization must have standards for what constitutes an agricultural product that is “organically” produced, and a system for ensuring that products it certifies meets those standards. Again, since each label claim is reviewed individually, the producer needs to contact FSIS him or herself. Contact:

Anita Manka  
USDA FSIS  
Labeling and Compounds Division,  
Labeling Review Branch  
Washington, DC 20250-3799  
(202) 205-0623  
FAX: (202) 205-0145  
<http://www.fsis.usda.gov>

While not required, code dating that identifies when a product was made can be very helpful. Remember that storage of the finished product is also regulated. Check with your local health inspector for information regarding storage.

Your label needs to be carefully chosen and designed to communicate the image you wish to

convey. A basic check-off label saves costs on label printing and design. These labels list all cuts of meat and the butcher checks the appropriate box. In addition to meeting legal requirements, the producer may want to consider getting a trademark to identify and distinguish their products in the market place. The trademark prevents others from copying the look or name of your product. There are state and federal trademark registrations. While it can take several months to a year and cost several hundred dollars, it may be worth it to ensure consumer recognition in today’s brand-conscious market environment.

Even if you choose not to register you may want to add the <sup>TM</sup> symbol to provide some protection. Despite popular belief, trademarks do not have to be registered for rights to be acquired. Anyone who claims rights in a mark may use the TM (trademark) designation which alerts the public to the claim. But bear in mind that the first person to register or file an intent to register the trademark legally owns it. Also, there is a difference between trademarks and trade names. Trade names, or the names under which you do business, usually do need to be registered with the state. A good source of information on this often confusing issue is the Small Business Administration (<http://www.sba.gov> or call 1-800-827-5722 or email [answerdesk@sba.gov](mailto:answerdesk@sba.gov)).

For comprehensive information on the legal issues surrounding marketing of meat, poultry, eggs and dairy products, including a state-by-state list of contacts, consult “The Legal Guide for Direct Farm Marketing” by Dr. Neil Hamilton (1999. 240 p. \$20.00 +\$2 s&h.) Order from:

Drake University Law School  
Agricultural Law Center  
2597 University Avenue  
Des Moines, IA 50311-4505  
(515) 271-2947

## DIFFERENTIATING YOUR PRODUCTS

- **Organic**

Organic certification, and the ability to identify organic products as “certified organic” in the marketplace, have been useful marketing tools for

over a decade. With producers now able to include the word "organic" on labels for meat products, the organic market represents a real

Some producers feel that marketing of "natural" meat has hurt sales of truly organically produced meats. Producers have to explain over and over

what the difference between "free-range," "natural," and certified organic is. Most successful producers provide educational materials to the stores that carry their products and usually do demonstration and other promotional activities as well (23).

When you contact a certifying organization, ask for their livestock standards and list of approved materials.

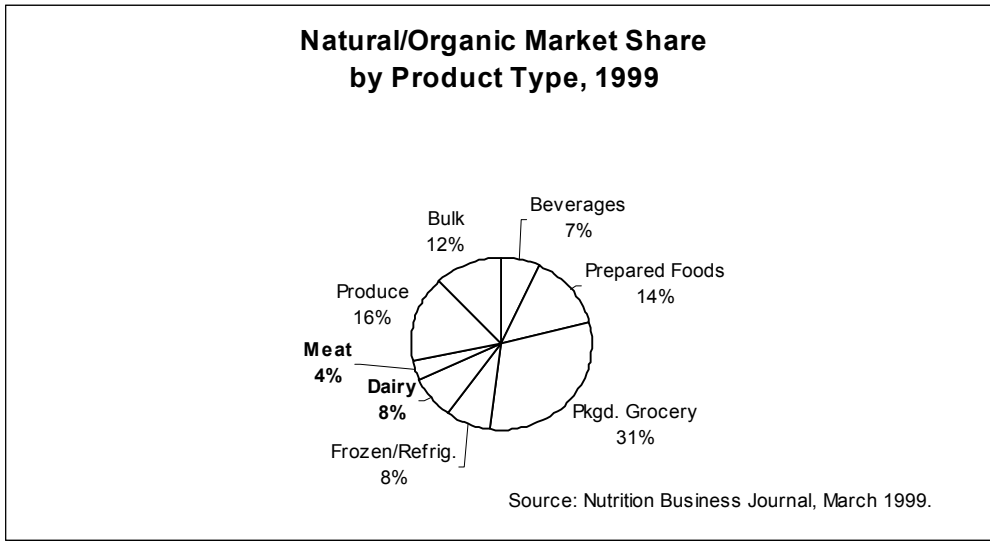

opportunity to add value to meat products. Many consumers who have stopped consuming meat because they didn't know where the meat came from or how it was produced are, with increased availability of organic meats, now adding meat back into their diets. Most producers indicate greater interest in their products from buyers, now that they can include "organic" on their labels. While most of these buyers are willing to pay more for organic products, price is more of a factor than with the gourmet niche. In addition to individual customers purchasing organic meat directly from the producer, organically produced meat can be marketed through health food retail stores and natural foods restaurants. Profit margins on meat run about 30% (21). However, organic producers must still contend with an immature and developing market that makes thorough planning all the more important.

Total sales of fresh meat (including seafood) were \$238 million in 1998 in natural products stores, accounting for only 2% of total sales. Organics at \$25 million represented 10% of the meat category. (In contrast, organic produce accounted for 66% of all produce sold (22)). While this does not take into account sales in mainstream stores or the large volume of direct-marketed meat, clearly, there is a lot of room to grow for natural and organic meats.

While standards for raising organic meat are relatively simple, the audit trail that most organic merchandisers require from their suppliers involves a lot of time-consuming paperwork, say farmers. For more information on organic certification, please contact ATTRA.

One of the first to begin marketing organically produced animal products, CROPP/Organic Valley has spearheaded the move to allow using "organic" on labels. Organic Valley spokespeople predict healthy growth in organic meat demand with sales in 2000 expected to nearly double from 1998's \$28 million (24). CROPP welcomes inquiries from interested farmers who are or can be certified organic, able to produce to CROPP specifications, and willing to become a CROPP member, including making an investment in the co-op. General information on CROPP is available from their web page (<http://www.organicvalley.com>) or by calling (608) 625-2602.

The *Upper Midwest Organic Livestock Producers' Directory* is intended for producers in Iowa, Minnesota, North and South Dakota and Wisconsin. The directory contains contact info for veterinarians, buyers, distributors, processing facilities, resources and resource organizations including producer cooperatives. Send \$5.00

(check payable to Cooperative Development Services) to:

Cooperative Development Services  
30 West Mifflin St. Suite 401  
Madison, WI 53703  
608-258-4396  
FAX: 608-258-4394  
E-mail: darcylk@inxpress.net

More general information on buyers, industry associations, and so on is available in the ATTRA publication *Resources for Organic Marketing*.

- **“Natural”**

Consumers remain unclear about the difference between “natural” products and “organic” products, a situation made worse by the USDA’s very broad definition of “natural.” Under current USDA policy, meat can carry the “natural” label if it contains no artificial ingredients (color, flavor, preservatives, etc.) and is minimally processed. Production methods are not considered by the USDA in granting permission to carry the “natural” label, meaning that nearly all cuts of meat can be called “natural.” In popular use, however, consumers often interpret (incorrectly) the term “natural” as meaning that the animals have been raised without growth hormones, routine antibiotic treatments, or feed additives. As consumers become more sophisticated, they are becoming more aware that a “natural” product may not offer the attributes they seek and more likely to read labels carefully. It can pay for a producer to include those special claims on the label.

Natural meats marketers are often seeking producers to fill growing demand. These marketers can be located using directories such as *Natural Food Merchandiser’s Retailer Purchasing Guide* (see **Resources**).

- **Grass-fed/Pastured**

Consumers are uncertain about market terminology such as “grass-fed” (commonly translated in their mind as “tough”). To capitalize on marketing opportunities from grazing-based

production, consumer education is needed. Consumers need to understand why grazing-based production is beneficial for the animals and for the environment. More importantly from a marketing standpoint, there is some evidence that meat and milk from grass-fed livestock is also beneficial to human health.

Conjugated linoleic acid, or CLA for short, is a modified form of the essential fatty acid linoleic acid (otherwise known as the omega-6 fatty acids) found in high concentrations in pastured livestock. Studies have suggested that CLA enhances immune function, acts as an antioxidant, and even lowers the risk of cancer. It may also play a valuable role in changing body composition by helping to decrease fat, while maintaining or gaining muscle (25). The combination of lower overall fat and possible health benefits from existing fat represents a potentially powerful marketing tool for the grass farmer. References on CLA are available at <http://www.wisc.edu/fri/clarefs.htm>. Additionally, the publication *Why Grassfed is Best!* provides exhaustive information on the benefits of grass-fed livestock products (see **Resources**).

Difficulties with grass-fed production in general include seasonal production, but year-round consumer demand. The additional time required to fatten grass-fed cattle may result in a tenderness problem. The yellow fat that can result from green grass in forages may result in lower prices received, because consumers are unaware that the yellow fat is beta-carotene storage. For more information on the grass-fed market, consult the ATTRA publication *Alternative Beef Marketing*.

- **Other Niches**

“Humanely raised” is another term with a very wide range of interpretations. Generally, organic certification will require that the animals are raised and processed humanely. Producers not wishing to become certified but who feel that promoting their good treatment of livestock will help sales should detail their production practices



for consumer and retailer educational materials. Providing, on consumer request, affidavits from reliable sources that can attest to the practices used is a good idea.

While at present this does not appear to be a viable niche in itself, it is certainly an important attribute in the natural meats market. A 1998 national consumer opinion survey conducted by the Animal Industry Foundation found that 44% of respondents were willing to try meat products labeled “humanely raised” if the cost were only 5% more than for conventional meats. A 10% price increase lowered the number who would buy to 20%, while at a 20% price increase only 6% of respondents were willing to buy (26). There are many organizations involved in promoting consumption of humanely raised livestock products. Perhaps the most influential is the Humane Society of the United States (see Resources).

Some livestock producers are successfully marketing based on their management of predators. Rather than killing predators such as wolves and coyotes, these producers use other methods to control predation. This appeals to the segment of the population that is concerned about preserving wildlife. The “Wolf Country Beef” label developed by Jim Winder and Will Holder, ranchers who have teamed up with the nonprofit Defenders of Wildlife, is an example. They're developing the seal-of-approval so that beef coming from ranchers who avoid killing predators will stand out in stores. Wolves can be an economic asset to the region, says Holder, who hopes the Wolf Country Beef program demonstrates that ranchers can live with wolves and still make money (27).

### • Ethnic And Religious Markets

Ethnic markets often offer opportunities for marketing livestock products that are not well accepted by mainstream America. Many cultures actually prefer meat from mature animals, such as the Muslim preference for mutton, which would be considered tough or stringy by others, and many ethnic cuisines use innards, feet, heads and other parts that would otherwise be thrown away. Products such as goat and mutton are not part of

the usual American diet. But goat, for example, is well liked by Hispanics, Caribbeans, and Muslims, to name just a few. When marketing meat from the same animal to different market outlets, the biggest challenge for the direct marketer is to balance the demands of the various outlets with the supply of the different cuts. Producers can use the special preferences of ethnic markets to balance out supply and demand problems. Jewish religious laws, for example, mean that this market prefers the front-end cuts that are difficult to market to mainstream America.

There are ethnic and religious niche markets available for nearly every type of livestock. Producers should develop a marketing plan consistent with the preferences of the ethnic groups in their areas. Even more “mainstream” meats like pork can be better marketed by targeting specific ethnic groups such as Hispanics or Chinese. Most mutton and a large proportion of goat is bought by those of the Muslim or Jewish religions. Meat slaughtered in compliance with the Islamic dietary laws is termed “halal” and that slaughtered in compliance with the Jewish dietary laws is termed “kosher.”

Providing facilities for the on-farm ritual slaughter is often necessary to serve the ethnic/religious market. Some producers have provided only a water hose, rope, and tree with a crossbar, while others have provided a room with a sink, chopping block, and hanging hooks. The requirements for Islamic halal meat are less stringent than those for Jewish kosher meat, which can be difficult to provide on a small scale. More information on ethnic and religious niches can be found in the excellent publication *Marketing Out of the Mainstream* (see Resources).

### REFERENCES

- 1) Hall, Bart. 1997. Marketing Organic Livestock Products. ATTRA Business Management Guide (out of print).
- 2) Staff. 1999. The real thing...Kansas grassfed beef co-op sells cowboy image. Stockman Grass Farmer. February. p. 15.

- 3) Wilson, Annie. 1999. Workshop Presentation "Organize to Stay Alive: Working with Other Farmers in a Co-op to Share Risks and Profits." North Central Region SARE Conference: Alternative Agricultural Marketing: Developing Skills for the New Millennium. University of Nebraska – Lincoln. November 20.
- 4) Staff. 1999. Ohio Agriculture Director Applauds Federal Legislation. Ohio Department of Agriculture Press Release. November 22.  
<http://www.state.oh.us/agr/Federal%20Legislation.htm>
- 5) Jost, Jerry. 1999. Marketing Grass-Fed Beef. Sustainable Agriculture Management Guide MG6A.1. Kansas Rural Center, KS.
- 6) Nation, Allan. 1999. Allan's Observations. Stockman Grass Farmer. May. p.13-17.
- 7) Mewbourne, Martha. Personal conversation, August 31, 1999.
- 8) MacKenzie, L. J. 1998. Copyright Livestock – Pay as They Grow Plan. MacKenzie & Associates.  
<http://agrihelp.com/payasgrow.htm>
- 9) Staff Report. 1998. Farmers' markets offer rural graziers direct marketing opportunities. Stockman Grass Farmer. June. p. 1, 5-7.
- 10) Slattery, Patrick. 1999. Making natural meat pay. Acres USA. Vol. 29. No. 4. p. 20.
- 11) DeVore, Brian. 1999. Allies on the direct marketing front. Successful Farming. September. Special Bonus Pages.
- 12) Jacobsen, Larry, and Kamyar Enshayan. 1999. Workshop Presentation "Tapping into Institutional Markets." North Central Region SARE Conference: Alternative Agricultural Marketing: Developing Skills for the New Millennium. University of Nebraska-Lincoln. November 20.
- 13) Bump, Jeff. 1996. Going direct. Pasture Talk. August. p.1, 3.
- 14) Goodman, Jim, and Brian Boehm. 1999. Workshop Presentation "Selling to Restaurants." North Central Region SARE Conference: Alternative Agricultural Marketing: Developing Skills for the New Millennium. University of Nebraska – Lincoln. November 20.
- 15) Endicott, Diana and Tom Moore. 1999. Workshop Presentation "Selling to Retail Food Markets." North Central Region SARE Conference: Alternative Agricultural Marketing: Developing Skills for the New Millennium. University of Nebraska – Lincoln. November 20.
- 16) Waters, Christina. 1997. Adding meat to the mixture. Natural Foods Merchandiser. November. p. 1, 45, 52.
- 17) Raterman, Karen. 1998. Industry distribution, competition, and the out-of-stock issue. Natural Foods Merchandiser. June. p. 42.
- 18) Bauer, Lisa. 1999. Cooperatively producing and marketing All Natural Beef. North Central Region SARE Field Notes No. 5. p. 1-4.
- 19) Endicott, Diana. 1999. Keynote Presentation "Diana Endicott's Natural Beef Cooperative." North Central Region SARE Conference: Alternative Agricultural Marketing: Developing Skills for the New Millennium. University of Nebraska – Lincoln. November 20.
- 20) Nader, Glen, et al. 1998. Natural Beef: Consumer Acceptability, Market Development, and Economics. UC SAREP 1996-97 Research and Education Report. University of California Cooperative Extension. At:  
<http://www.sarep.ucdavis.edu/grants/Reports/nader/INDEX.HTM#TOC>
- 21) Clute, Mitchell. 1999. In a jittery market, everyone's wired. Natural Foods Merchandiser. June. p. 1, 36, 37.
- 22) Staff. 1999. Natural Foods Merchandiser Market Overview 1998. June. p. 60.
- 23) Staff. 1999. Livestock roundtable. Organic & Natural News. July. p. 24-26.
- 24) Looker, Dan. 1999. Quite the CROPP. Successful Farming. Vol. 97, No. 10. p. 19-22.
- 25) Dolby, Victoria. No date. The good news about fat – A love/hate relationship. No date. At <http://www.fitnesszone.com/article.html>

- 26) Anon. 2000. Animal rights survey. Small Farm Today. March/April. p.10.
- 27) Phillips, Sara. 1998. Red meat can be green. High Country News. Vol. 30, No. 2. At: <http://www.hcn.org/1998/feb02/dir/Hots302.html>

## RESOURCES

---

### • *General*

*Stockman Grass Farmer* offers practical information on producing and marketing. An excellent resource for any sustainable livestock producer. \$28/year from:

SGF  
PO Box 2300  
Ridgeland, MS 39158-2300  
800-748-9808  
FAX: 601-853-8087

### • *Small Ruminants*

*Marketing Out of the Mainstream* is available at <http://www.sheepusa.org> (under "The Marketplace"). While specifically covering lamb and wool, the publication offers valuable information for any meat marketer.

An outstanding source of marketing information for meat goats is the E. (Kika) de la Garza Institute for Goat Research. They offer a comprehensive series of fact sheets covering meat goat marketing and information on consumer demand for goat meat. These are available on the Internet at <http://www.luresext.edu/goatext.html>, or by contacting:

Langston University  
P.O. Box 730  
Langston, OK 73050  
(405) 466-3836  
FAX: (405) 466-3138

### • *Processing*

American Meat Science Association  
1111 North Dunlap Avenue  
Savoy, Illinois 61874  
(217) 356-3182  
FAX: (217) 398-4119  
<http://www.meatscience.org>

Arlis Burney  
Food Processing Center, University of Nebraska  
143 Filley Hall  
Lincoln, NE 68583-0928  
(402) 472-8930  
E-mail: [aburney1@unl.edu](mailto:aburney1@unl.edu)  
<http://foodsci.unl.edu/fpc/market/ent.htm>

AURI's meat laboratory and pilot plant in Marshall, MN, offers small meat processors the opportunity to test out ideas for value-added processed products for both humans and pets. In addition to assistance with product development, AURI offers HACCP training and periodically gives workshops. Only available to Minnesota residents. For more information, call Darrell Bartholemew at (507) 537-7440 or visit <http://www.auri.org>.

Texas A&M offers meat science information and training seminars such as "Beef 101" and "Sausage School" to producers. Contact:

Ray Riley  
Rosenthal Meat Science and Technology Center  
Department of Animal Science  
Texas A&M University  
(409) 845-5651  
FAX: (409) 847-8615  
E-mail: [ray-riley@ansc.tamu.edu](mailto:ray-riley@ansc.tamu.edu)  
<http://meat.tamu.edu/>

**Note:** Sausage mix that does not contain MSG can be purchased from the KOCH company (800-456-5624) for use in processing.

### • *Legal Issues*

The National Center for Agricultural Law Research and Information (NCALRI) at the University of Arkansas offers links to state and federal environmental laws that affect agriculture at their Web site: <http://law.uark.edu/arklaw/aglaw/envlinks.htm>. NCALRI staff attorneys can address specific legal questions, within the areas of their expertise, from farmers, attorneys, agri-businesses, agricultural organizations, and federal and state governmental entities. For more information contact:

NCALRI  
147 Waterman Hall  
University of Arkansas  
Fayetteville, AR 72701  
(501) 575-7646  
FAX: (505) 575-5830  
E-mail: [swillia@comp.uark.edu](mailto:swillia@comp.uark.edu)

- *Niches*

*Why Grassfed is Best!* by Jo Robinson, offers 107 pages of information and resources on health and environmental benefits of eating grass-fed livestock products. It is available for \$7.50 plus \$2.50 s&h (single copy rates) from:

Columbia Media  
2401 N. Cedar  
Tacoma, WA 98406  
(206) 463-4156  
FAX: (206) 463-4666

Make checks payable to Columbia Media.

For more information on the *Retailer Purchasing Guide* contact:

Natural Foods Merchandiser  
New Hope Natural Media  
Circulation Department  
1301 Spruce Street  
Boulder, CO 80302  
(303) 939-8440  
FAX: (303) 473-0519

For more information on the "Good for You: Choosing a Humane Diet" campaign and the Eating with Conscience Programs, contact:

The Humane Society of the United States  
Farm Animals and Sustainable Agriculture  
2100 L Street, NW  
Washington, DC 20037  
(202) 452-1100  
FAX: (301) 258-3081  
E-mail: ewcp@hsus.org  
<http://www.hsus.org>

For more information on the Wolf Country Beef program, contact the Defenders of Wildlife Southwest office at (520) 578-9334 or:

Jim Winder  
Lake Valley Ranch  
HC 66, Box 38  
Deming, NM  
(505) 267-4227

Other producers marketing predator-friendly meats include Ervin Ranch. For more information:

(520) 428-0033  
E-mail [info@ervins.com](mailto:info@ervins.com)  
<http://www.ervins.com/wildlf.htm>

The electronic version of *Alternative Meat Marketing* is located at:  
<http://www.attra.org/attra-pub/altmeat.html>

---

**Prepared by Holly Born  
NCAT Agriculture Specialist**

---

**May 2000**

The ATTRA Project is operated by the National Center for Appropriate Technology under a grant from the Rural Business-Cooperative Service, U.S. Department of Agriculture. These organizations do not recommend or endorse products, companies, or individuals. ATTRA is located in the Ozark Mountains at the University of Arkansas in Fayetteville at P.O. Box 3657, Fayetteville, AR 72702. ATTRA staff members prefer to receive requests for information about sustainable agriculture via the toll-free number 800-346-9140.





Appropriate Technology Transfer for Rural Areas  
[www.attra.ncat.org](http://www.attra.ncat.org)

# DIRECT MARKETING

**BUSINESS MANAGEMENT SERIES**

ATTRA is the national sustainable agriculture information center funded by the USDA's Rural Business -- Cooperative Service.

**Abstract:** *This publication on direct marketing alternatives – with emphasis on niche, specialty and value-added crops – features many farm case studies, as well as information on enterprise budgets and promotion/publicity. A new section discusses implications of Internet marketing and e-commerce for agriculture.*

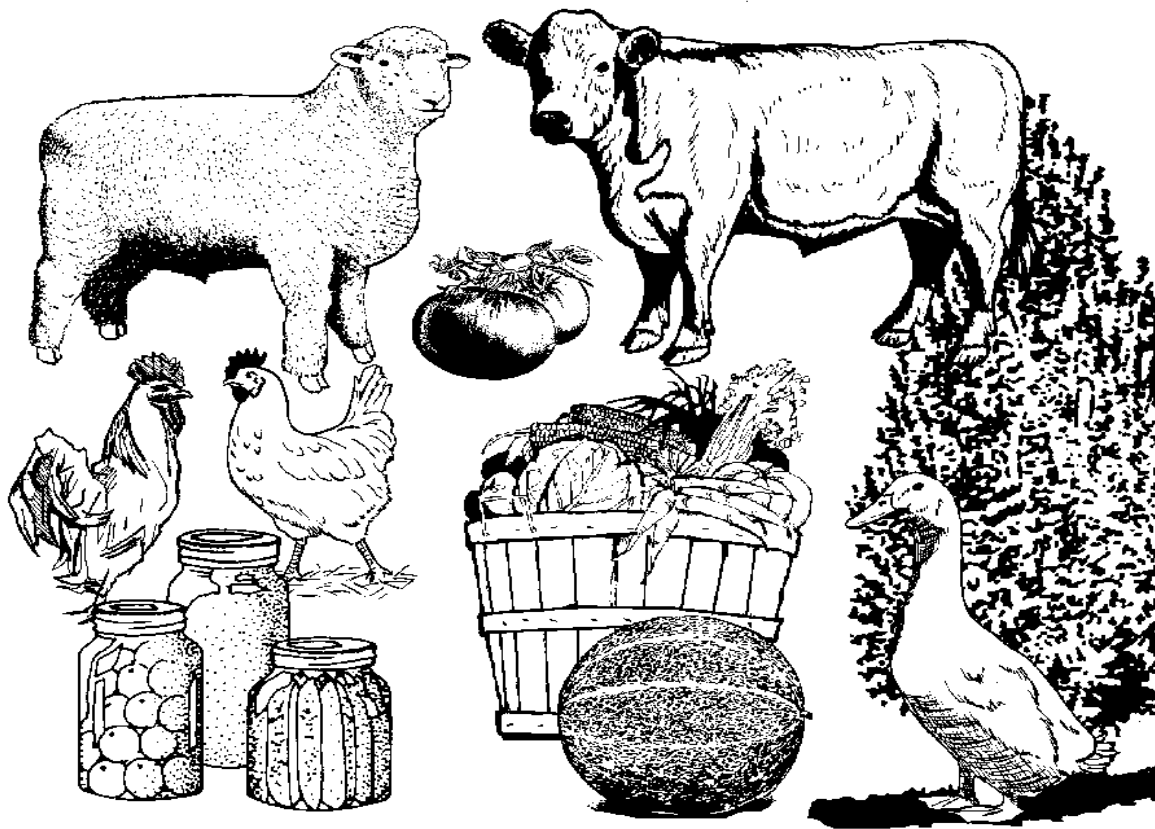

## CONTENTS:

Introduction.....	2	Value-added marketing .....	11
Alternative marketing .....	2	Pricing and profitability .....	13
Present system.....	2	Direct marketing alternatives .....	15
Exploring alternatives .....	2	Marketing on the Internet.....	18
Why direct marketing? .....	3	Promotion and publicity .....	19
Importance of marketing .....	3	Conclusion .....	23
Niche marketing .....	7	References.....	23
Specialty crops and diversification .....	9	Resource list.....	25



**By Katherine Adam, Radhika Balasubrahmanyam, and Holly Born  
NCAT Agriculture Specialists  
November 1999**

## **Introduction**

Many growers, especially new ones, are inclined to start production without giving a second thought to the business of marketing. Good marketing is an absolute must for a successful agricultural enterprise. Some would even argue that it ranks higher in importance than production itself—especially for farmers planning to diversify. After all, what good is a product if one cannot sell it consistently for a profit?

Diversification out of commodity crops may mean becoming familiar with, or even creating, new marketing systems. Existing marketing channels very often do not accommodate the new producer well—especially the small producer.

This publication describes direct marketing of produce (and to a lesser extent livestock) and lists additional resources for those who are interested.

ATTRA has more information on marketing animal products. Some farmers may use direct marketing for particular products while simultaneously participating in traditional markets. No two growers are the same, and the reader will have to determine through trial and error what works best.

## **Alternative marketing**

Formal research on alternative marketing mechanisms has been scattered and hard to access by producers. It is mostly experiential and unrecognized by the agricultural establishment and official information channels. Small farmers and grassroots farm groups are the most likely to

develop and use innovative marketing methods (1). The assumption that farmers must either “get big or get out” is being challenged, however, by the emergence of alternatives. It is possible for innovative farmers to stay small or medium-sized *and* make a comfortable and successful living from agriculture (2).

## **Present system**

Less than 2% of the U.S. population farms, a fact often cited as proof of the extraordinary efficiency of U.S. agriculture. Technical strides in production and processing have made more food available to more people around the year. For better or for worse, farmers are constrained by a highly specialized system characterized by a few large farmers and processors, and a production and distribution system increasingly integrated at all levels for the sake of efficiency and economies of scale.

Vertical integration of markets and consolidation of processing are especially pronounced in the livestock industry, where a handful of firms control broiler production, as well as hog and cattle slaughter. By 1996, almost 100% of broiler production was by contract (3). Since 1996 hogs sold to packers by “pre-arranged agreements” (contracts) have increased from 17% to over 60%, according to a study by agricultural economist Glenn Grimes of the University of Missouri (4). In many cases, the products are specified in such great detail in the contract that the farmer is not selling an agricultural product, but is selling his labor (5).

## **Exploring alternatives**

Sustainable farming, which received a boost following the farm crisis of the 1980s, has given impetus to diversified, decentralized systems in which farmers take greater control of marketing by bypassing traditional channels and marketing

When Mike and Jennifer Rupprecht sell beef direct to consumers, they make approximately \$200 more per animal than if they had sold it to a large packing plant. Their consumers save at least \$250 over what it would cost them to buy the equivalent amount in steak, roasts and hamburger in the store...

...The Minnesota Department of Agriculture estimates that in 1994, more than \$31 million were generated through the state's 354 custom meat plants in sales and processing fees, from directly marketed meat. Of this, farmers received an estimated \$22.1 million.

**From The Land Stewardship Letter, November-December 1995.**

directly to consumers at the local and regional level. Foods that do not require much processing before consumption—like fruits, vegetables and meat—are ideal for one-on-one marketing. Direct marketing is often quite unorthodox and may take the form of roadside stands, pick-your-own operations, farmers’ markets, and sales to restaurants, upscale retail or specialty stores—even supermarkets and institutional food service. Prospects for direct farmer-consumer interaction are particularly promising at the rural-urban fringe, where producers can take advantage of specialty market niches and the demand for local and ethnic food and non-traditional products, while promoting agricultural tourism and education.

### ***Why direct marketing?***

It is the excesses of the conventional marketing system that have forced the return of direct marketing. Consumers tired of tasteless supermarket produce and factory-raised meat (and with increasing concerns about food safety issues) want fresh food with flavor, as well as more control over their food supply, and are willing to pay a premium price for it.

Direct marketing, also called “shopping with a human face,” promises “vine-ripened tomatoes that won’t bounce if dropped and are full of the flavor you remember (6).”

Direct marketing can give the farmer a larger share of the food dollar and possibly a higher return on each unit sold, offset to some extent by loss of economies of scale. For some farmers, adding value or marketing some minimally processed farm products directly to the consumer is a way of enhancing financial viability. Farmers who are unable to compete in, or are locked out of, distant markets can build a thriving local

business. However, finding the right niche and marketing directly to the public is a hard and labor-intensive job requiring time and effort, creativity, ingenuity, sales expertise, and the ability to deal with people in a pleasant and positive manner. Agricultural producers must be absolutely sure they are ready for the job.

### ***Importance of marketing***

For too long, farmers have thought of marketing as simply how to dispose of their products. Locked into producing a very small number of major crops and insulated from the market, they have not been required to have a clear understanding of ever-changing consumer wants and needs. Producers have traditionally taken whatever price they could get while wholesale and retail distribution networks undertook the business of marketing.

Marketing does not begin *after* production, but well *before* the first seed is planted. For farmers working outside the conventional system, the importance of marketing cannot be over-emphasized. Consumer-focused marketing is the single most important factor that determines the success of an enterprise. Marketing is not just about selling. It requires a clear and astute understanding of what consumers want and the ability to deliver it to them through the most appropriate channels *for a profit*. It includes the planning, pricing, promotion and distribution of products and services for consumers, both present and potential. According to specialty vegetable grower Don Anderson: “Knowing what’s happening in the marketplace is the difference between the farmer who makes it and the farmer who doesn’t make it” (7).

### ***Enterprise evaluation***

A good marketing strategy begins with making sure the enterprise is right for you and is feasible. This will require a review and evaluation of your present situation, goals, possible enterprises,

#### **What are the qualities of a successful marketer?**

Takes pride in the product and is not shy about saying so  
Flexible  
Creative

Not afraid to take risks  
Willing to plan, research and experiment  
Independent  
Thrifty

From Market What You Grow by Ralph J. Hills, Jr.

### ***Market development***

There are four basic ways to create a market (8):

✓ *market penetration*, where the producer uses more of his current product mix to meet the needs of the market. This could mean boosting sales by improving linkages between the buyer and seller and serving more customers in the existing market or by increasing consumption per customer.

✓ *market development*, where the producer looks for new uses or new markets for the product.

✓ *product development*, where a new product is produced for the existing market. This could be something that is less expensive to produce, or value added to the original product or crop so that it meets the customer's needs better.

✓ *diversification*, where the grower raises new products for completely new markets.

physical, financial and marketing resources, and market potential. The evaluation should help you answer some key questions, chiefly: Is this really what you want to do? Is there a market for the product? Do you have the necessary skills to do it? Are you going to develop the market? Or will you raise a crop for which there is a pre-existing market? Will it be profitable? Can you expand in the foreseeable future? A sample feasibility study for an agricultural enterprise may be found on the University of Georgia Extension website at:  
<http://www.ces.uga.edu/pubed/b1066-w.html> (9).

- ♠ Start by listing your business and personal goals. Prioritize them.
- ♠ Is this going to be a full-time enterprise?
- ♠ Is your family involved and supportive?
- ♠ Inventory physical resources like land, soil, machinery, water, buildings, livestock etc. Define constraints.
- ♠ Is family and/or off-farm labor available?
- ♠ Is your spouse involved in the planning? A spouse's knowledge of medicinal herbs or

cooking could spin off into an additional on-farm enterprise.

- ♠ Do you have access to financial resources in the form of savings, credit or investment by family or friends?
- ♠ What are some of the crops that will grow well in your area and will fetch the price you need?
- ♠ What are the marketing resources in your region? Check out the farmers' markets and the retail stores. Is a roadside stand feasible? Talk to others who have one. Are there restaurants, grocery stores and supermarkets willing to buy locally raised produce or meat?
- ♠ Who are your potential customers? Would they like to buy direct-marketed products or do they prefer buying at mass retail outlets where price is the main consideration? Is there scope in your business plan for consumer education? Have you considered the potential for entertainment farming and tourism?
- ♠ What information and resources do you need to help you along the way? How can you best access such resources?

### ***Market research***

Following this preliminary survey, begin to identify and define your product. Get all the information you can about sources, marketing, production, processing, packaging and sales. This will require a good bit of systematic research. Check the libraries in your area. Read all the USDA and Extension publications you can lay your hands on as well as trade journals and periodicals, books on market gardening and seed catalogs.

Talk to your Extension agent, visit the local stores (gourmet and otherwise) and supermarkets to see what is selling, and why one product appears more appealing than another. Talk to customers, local stores, food clubs, specialty distributors, ethnic stores, restaurants and other prospective outlets in your region. What do they want? Is there an unfilled niche? With your production, labor and marketing resources, will you be able to fill this niche?



## Why market research?

Information from market research helps to formulate a market strategy and project profitability. Two levels of information may be obtained:

### General:

Food shopping habits;

What are some trends in lifestyles? convenience? Emphasis on family time and homecooked meals?

What is the ethnic and racial make-up of population, what are its food preferences?

What are the trends in food safety, health and nutrition?

What are the marketing trends? Growth in organics? An emphasis on freshness?

### Specific:

Who are the buyers? What are their ages, incomes and lifestyles?

What are their wants?

Size of the market, number of buyers;

Number of competitors; are they successful? What are their weaknesses?

What price can you expect?

How much of the market can you expect to hold?

What are packaging and labeling requirements?

What are the barriers to market penetration for the products you have in mind?

Find out what your prospective competitors are doing. Look for ways to improve upon what they are offering. Useful exercises for defining the competition and customer base can be found in Geraldine Larkin's book *12 Simple Steps to a Winning Market Plan* (see **Resources**). For use in researching the market for new farm-based enterprises, Judy Green of Cornell University has compiled a list of agricultural alternatives. (For a copy of this list, request the ATTRA information on evaluating a rural enterprise.) Information on doing your own market research is also available from ATTRA.

You can either start small and grow bit by bit, or you can start in a big way from the very beginning. Either way, you must be prepared to do your homework and get to know your markets to be successful. One way to identify potential markets that exist in your area is by using the "30-mile market technique" (12). Most customers of direct marketers are believed to live within 30 miles of the point of sale. Market research within this radius will unearth useful information about production possibilities and the presence of competitors. Detailed market analysis and research is imperative before you promote and sell your product. Not only does it

reduce business risk by providing credible information, it can help identify problems in the market as well as little-known opportunities for profit. By knowing the size and makeup of your market, its geographic location, demographic and behavioral characteristics, it will be easier to create the appropriate marketing strategy and you will avoid wasting time and money marketing to the wrong people.

### *Marketing plan*

Marketing is an essential element of a small agricultural enterprise. The marketing environment will ultimately exert a strong influence on the nature of the business. The crop grown will be determined less by the farmer's personal tastes than by what the market will absorb at a price the farmer is willing to take. A good market plan broadly aims to define the consumer, the products or services they want, and the most effective promotion and advertising strategies for reaching those consumers (13). It clarifies objectives, appropriate actions, projected income, pricing structures, costs and potential profitability. A step-by-step business planning tutorial for a direct marketing enterprise is available at <http://fbimnet.ca/bc/>.

A market plan alone does not guarantee success, but it does indicate that many of the factors that affect the profitability and continued survival of the operation have been given consideration. A market plan is usually part of a larger business plan that includes production, financial, staffing and management plans. The process of writing a business plan is not within the scope of this paper but listed at the end of this section are resources to help you find more information on the subject.

A good place to start is the Small Business Administration, a federal agency that operates small business institutes and development centers, SCORE (Service Corps of Retired Executives) and publishes business publications. Each state has an SBA office that may be approached for help with developing a marketing or business plan.

Elements of a marketing plan are (14):

✓Marketing situation—a summary of your present situation, what you are currently selling and how, who your customers are, what their needs are, your competition, your own strengths and weaknesses, how you are promoting your product, what the current food and marketing trends are, etc.

✓Marketing objectives—a summary of your short and long term goals, product diversification, additional market segments (alternative outlets) to tap. Objectives should be realistic and measurable—e.g., you would like to increase sales by 10% within the next year.

✓Marketing strategies—ways to achieve your goals, what you will produce, how you will promote and advertise the new product, the channels of sale, how you plan to beat your competition.

✓Budgets—include estimated costs and return based on sales, and strategies for monitoring and curtailing costs.

✓Action plan—immediate steps (e.g., look in the yellow pages for graphic artists to design logo, shortlist names of newspapers for a press release, assign person to deliver products to market, etc.)

✓Evaluation—a summary of progress on marketing objectives. The frequency of evaluation depends on the plan and could be each month, every six months or annually.

Objectives and strategies are a dynamic part of the planning process and change depending on the market situation and competition.

### Domestic food demand - some trends to keep an eye on:

Demography: There will be fewer new U.S. households formed through the year 2010. There will be a greater proportion of single-person households as well as families without children. Households with two adults and one child will fall from 25% of the total to 20% over the next 15 years. *The Packer's* annual *Fresh Trends* survey found that one-person households already account for 25% of buyers. This information implies larger demand for single-serve products and produce, and higher per capita food spending in one and two-person households.

Health and nutrition (10):

#1) Products perceived to be fresh will have the strongest competitive advantage. According to a survey reported in *The Packer's* 1997 supplement "Fresh Trends," 17% of the respondents had purchased one or more new fresh vegetables every year.

#2) Shoppers are looking for taste and may be less willing to compromise this for health. So, if a product is both healthy and tasty, it is guaranteed to be a winner.

#3) Since 1990, the claims "natural" and "grown without pesticides" are the only two labels that have grown in importance relative to others.

#4) Aging baby boomers will push new product positionings and define the market for health foods.

#5) More and more consumers will recognize the connection between nutrition and health.

Safety (11):

The buzzword in 1999 is "local." "Country of Origin" labelling was overwhelmingly (85%) favored by produce consumers participating in the Packer Survey. In fact, 63% favored *mandatory* labelling. This can only work to the advantage of local producers.

## Niche marketing

Anyone can pick a bunch of vegetables or fruits, set up a stand at the local farmer's market *et voila!* a direct marketer is born. However, what is it that differentiates a successful marketer from the rest of the pack? James McConnon, Business and Economics Specialist at the University of Maine Coop Extension says that in order to survive in a world of mass retailers, it is absolutely imperative to find and fill a niche that is not filled by the mass retailer (Wal-Mart, Safeway) (15). In addition, he lists three other survival strategies: good promotion, good service, and good customer relations.

The following section focuses on creative marketing tips, including specialty and value-added marketing, using examples of farmers who have built a successful direct marketing business.

### What is a niche market?

- ✓ A target group whose market responses are similar to each other, but different from other groups.

What makes a niche market worthwhile for the farmer?

- ✓ There must be accessible information about the group.
- ✓ The group must be reachable through clearly identified information channels.
- ✓ The group must be big enough and sufficiently profitable to make it worth targeting.
- ✓ The nature of a niche market is that it tends to disappear after awhile. Frieda Caplan, whose company introduced the kiwi to America, stopped selling kiwis in 1990 because over-supply and falling prices had eliminated the niche.

## Product differentiation

A very elementary way of differentiating one's product is to take it directly to the consumer. It is relatively easy for a direct marketer to promote a product as farm-fresh and different from the one sold at the mass retail store. Other ways to differentiate your product are by producing it earlier in the season, marketing it as low-spray (see box) or organic or naturally-raised, and by adding value to it in some other way. Cut flowers arranged into bouquets, garlic turned into decorative braids or wreaths, prewashed and bagged vegetables, bunched fresh herbs—these are a few simple ways to add value to products.

### Blemishes Only Skin Deep, says Orchardist

ATTRA specialist Guy Ames of Ames Orchard and Nursery markets his low-spray apples as ecologically raised. Ames, committed to growing healthy food for the community, is forced to spray for the plum curculio, an insect he is unable to control entirely through organic means. He uses Imidan once or twice during the season (unlike conventional growers who rely heavily on more persistent pesticides, spraying up to 12-14 times in the season for a cosmetically perfect product). Part of Ames' marketing strategy is to educate consumers to disregard minor blemishes on fruit and instead appreciate its freshness and wholesome flavor. Buyers can get a taste of the produce at the Fayetteville, AR, farmers' market three times a week in season.

(see Resources for publications on eco-labeling.)

Consumer concerns with pesticides in food, freshness, nutrition, and flavor have turned the organic food movement into a multi-million dollar industry. The changing racial and ethnic mix of the population signals an increase in the demand for exotic and unusual vegetables and meats. Not least exciting of all is that people are rediscovering the pleasure of fresh ingredients from local farms—a more meaningful connection to the land (16).

The one advantage that direct marketers have over retailers is the ability to build their relationships with customers over time. Indeed, good marketing is *about* building trust and personal loyalty in the relationship. Good sellers know and use the customer's name. Consumers who feel an emotional bond to the grower are likely to remain loyal, even though the product is available at the grocery store at a cheaper price.

Marketing gimmicks will not hold customers unless accompanied by an excellent product and superior service. Conventional marketing wisdom has it that 80% of sales come from 20% of

customer base. The grower must build a core customer base and let them know how important they are. Word-of-mouth advertising is the most effective and inexpensive way to attract new customers (17). Stay on top of consumer trends. The best-made product in the world will not sell if it isn't something people want.

Education of the consumer plays a big part in salesmanship. Most people, for instance, are oblivious to the environmental and health benefits of livestock raised on forage.

Conveying information about the farm, how the product is raised and why it is raised the way it is, the effect of recent weather on the crops, and other farm-centered conversation is important. Not only is this good for business, it also is a small step toward the development of consumer awareness of the farm and of social and health issues. Once customers know that you are providing healthy food, they gladly take on the responsibility to support local farmers. Help *them* help *you* run your business successfully and profitably.

Write up your farm or company's mission statement and display it to your customers and

employees. Let them know why you are in business and the direction you'd like to go. A simple mission statement may read like this: "Helping people stay healthy with fresh, locally grown food!"

Keep up with trends. Flexibility allows you to adapt your product mix to market fashion and trend. Remember, by the time you read that "crop X" is THE hot thing this year, it's probably already too late to cash in on it. You have to be the first to capture, or better yet, create the next hot thing. Visit specialty stores and restaurants—even if you aren't interested in selling to them—to find out what food items professionals see as the trends to watch. Food fashions get started by upscale restaurants and trickle down to the consumer gradually. Read what your target customers are reading.

Food and food trade magazines and women's magazines, in particular, offer great information. Another source is medical research on the health benefits of various foods, as reported in the popular press (also an excellent source of promotional information in today's health-conscious society).

Some resources you can use to educate the consumer about the benefits of fresh fruits, vegetables, and meat are:

☎ Nutrition Action Health Letter  
Center For Science in the Public Interest  
Suite 300, 1875 Connecticut Avenue NW, Washington DC 20009-5728  
202-332-9110; e-mail [cspi@cspinet.org](mailto:cspi@cspinet.org), <http://www.cspinet.org>

☎ Produce For Better Health Foundation  
1500 Casho Mill Road  
Newark, DE 19711  
302-738-7100  
<http://www.dole5aday.com>

PBHF has been licensed by the National Cancer Institute to promote the 5-a-day Program developed by NCI. PBHF is sponsored by the produce industry.

☎ Mothers and others

40 West 20 Street  
New York, NY 10011-4211  
e-mail: [Mothers@mothers.org](mailto:Mothers@mothers.org), <http://www.mothers.org>  
West Coast Office: e-mail: [WestCoast@mothers.org](mailto:WestCoast@mothers.org)

(Publishes The Green Guide. Its primary project aim is to build demand for a better quality food system, to open the marketplace to make it more responsive to consumer needs, and to create market opportunities for regional, sustainably produced food.)

### *An eggsample of creative marketing*

According to Jeff Ishee, a farmer with many years of marketing experience under his belt, if only people knew how commercial layers are managed, they would be flocking to the local market to buy free-range or humanely produced eggs. Laid by hens that are allowed to roam free and have access to fresh air and a rich and varied diet, these eggs have a rich yellow yolk compared to the pale watery insides of factory-produced eggs, and a freshness and good taste that only old-timers recall from their childhood.

To take advantage of the market potential for farm-fresh eggs, talk to buyers about the differences between eggs raised naturally and those sold at the store. Explain why your product is nutritionally superior (a little research helps—see box above), present your point of view pictorially, display photographs of your hens and let the consumers connect. The education helps not just to aid in consumer awareness, but is also a great sales booster. People who feel responsible for their health and recognize instinctively the value of your product will be back for more. And they won't mind paying more for your eggs!

### **Specialty crops and diversification**

Because an enterprise has a better probability of survival if it has a range of products to sell, diversification (especially into a mix of specialty or high-value crops) will benefit many producers. Specialty crops are generally not produced and sold in mass quantities. They have a high cash value per acre, grossing between \$4000–\$20,000 per acre. They are not necessarily exotic and include crops that need a lot of care to raise (and are therefore outside the traditional wholesale loop). They may be crops with special attributes like vine-ripened tomatoes or lean meat, or those raised especially for ethnic markets (7).

### **David and Lisa Reeves Waterfall Hollow Farm, AR**

#### Niche marketing with grass-fed beef (18)

☞ The two defining characteristics that differentiate the Reeves from other beef cattle farmers are their product and market. When they first set out to direct market, they were determined to give the public an opportunity to eat the kind of beef they grew for themselves. Convinced that there was a niche market for clean, range-grown beef, they proceeded to sell a product that was free of unwanted chemicals, growth hormones, and antibiotics.

The Reeves maintain that conventional wisdom does not apply in the marketing of grass-fed beef. Beef raised entirely on grass has the leanness of wild game and the flavor of sweet beef. It is not heavily marbled as is grain-fed beef. The cattle are butchered between the ages of 18–20 months—the younger the steer, the more delicate and tender the meat. Not much fat needs to be trimmed off the carcass and the beef is sold with cooking instructions and recipes.

It took some time and some “crushingly expensive mistakes” for the Reeves to learn how to tap into their niche market. Glossy advertising in the local tourist guides (*Bon Appetit*, *Eureka Springs Dining Guide*, *Guide to Local Businesses*), press releases and bulk mailings brought few or no sales. The poor response convinced them that they were better off addressing themselves exclusively to the small percentage of meat-eaters who frequent health food stores or similar establishments and who would buy organic meat. On the down side, of course, was the fact that many health food stores themselves steer clear of red meat because of perceived health risks. Their mission is now to:

convince them that there are people out there who will joyfully eat clean, “range”-grown beef, precisely because of the health benefits. We show them photos,

and describe the ranch and the lives of our cattle. We point out the obvious that beef is a very high-quality, nutrient-dense source of protein and obscure nutrients like B12, folic acid and zinc, that it is utterly delicious and deeply satisfying.

Today, their main wholesale outlet is the Ozark Cooperative Warehouse in Fayetteville, Arkansas. The warehouse itself markets only their ground beef but trucks orders to buying clubs—groups of private individuals in 11 states—and allows the Reeves to ship on their truck. This is an enormous bit of luck because it allows them to ship their product out of state for very little expense. The other, and more costly alternative, would be to use delivery services like UPS and Federal Express, which do not have freezer trucks and require insulated packaging.

Lisa notes that they really ought to invest more time and effort into in-store presentations and demonstrations. They've refrained from this partly because they do not wish to offend vegetarians present in the store and partly because they are still uncomfortable playing the role of salespeople.

Yet, store managers have found their obvious naiveté and lack of sophistication refreshing, their "hemming and hawing and just talking about their product" different from the spiel of professional sales people. The couple do not make "cold" calls but prefer to write a letter of introduction in advance before paying a visit to the store.

Their ideal marketing strategy would entail getting to know all the mainstream grocery stores

with alternative clientele, and health food stores within a three-hour driving radius, contact them on a regular basis—perhaps weekly, bi-weekly or monthly—and keep the stores regularly stocked with their product. So far, they have been able to sell everything they produce without actively marketing. Recently, they have been in contact with ranchers in Missouri and Arkansas who share their philosophy. The Reeves hope to buy some of their cattle or contract with them to grow beef animals, and expand the marketing end of their business soon.

## **Joan and Richard Wrench, Helena, MT**

Montana-based growers Joan and Richard Wrench have been raising garlic as a specialty crop since 1971. They currently give about 8 seminars a year at universities and through USDA, available at reasonable cost, to teach other farmers how to create a plan for farm independence through raising specialty crops. They are willing to help individual growers or groups wanting to establish a specialty crop enterprise with developing a market and business plan. They may be reached at 406-752-3127 between 8-9:30 am MST.

## **James and Alma Weaver, Kutztown, PA**

The Weavers grew tobacco and cattle on their 80-acre farm for several years before making the switch to specialty farming. The change has permitted them to survive in agriculture when other less flexible operators have been forced to bail out. The Weavers raise approximately 100 different kinds of herbs, a range of flowers, several varieties of ornamental colored corn, more than 100 varieties of peppers, 54 varieties of heirloom tomatoes, 30 different vegetables including some odd-sounding heirloom varieties like Cherokee Trail of Tears beans, Speckled Mennonite lettuce, and Amish Moon and Stars watermelons (19).

## **Steve Salt, Kirksville, MO**

☞ Steve Salt (20), a Missouri-based farmer who raises 600 kinds of vegetables, fruits, and herbs for sale at farmer's markets, restaurants, and via

household subscriptions, has a book coming out in November 1999 on specialty ethnic produce. Salt says that Asians, Middle-Easterners, Mediterranean Europeans, and Latin Americans, all of whom have a higher per capita consumption of fresh fruit and vegetables than Americans of northwest European heritage, also have a strong tradition of buying their produce unpackaged, at open air markets where they can examine or taste it before purchase. Supermarkets have been unable to cater to the needs of these people, and Salt writes that raising produce for ethnic markets offers a promising specialty niche

where the small grower can compete profitably with the big growers. In addition to direct retail sales, he recommends small-scale (wholesale) marketing to ethnic restaurants and grocery stores (21).

A wide variety of Asian vegetables, once a stronghold of the ethnic market, more and more cross over into the mainstream produce section. Primary markets are ethnic stores, grocery store chains and restaurants. Market data is hard to obtain partly because the truck farmers who raise crops for ethnic markets have generally operated outside conventional channels. Some information on prices and availability may be obtained from *The Packer* and *Produce Business* (see **Resources**).

Frieda Caplan, an authority on specialty produce (see her home page at <http://friedas.com/about.cfm>) says that consumer education is extremely important when marketing specialties to the general public. This is no less true of Asian vegetables, the popularity of which has been fueled by ethnic restaurants and educational campaigns by retailers to demystify the preparation of Asian foods through user-friendly packaging and recipes. For a brief summary on market potential, refer to the publication *The U.S. Market For Miscellaneous Oriental Vegetables* by Mihir Desai (listed in the **Resources** section).

### *Value-added marketing*

Value-added is a relatively new term in direct marketing jargon. Simply put, it means processing or modifying the product through

“cooking, combining, churning, culturing, grinding, hulling, extracting, drying, smoking, handcrafting, spinning, weaving, labeling, and packaging” (22). Other ways to add value to an agricultural product include:

- ♣growing something in a way that is acknowledged as safer, or
- ♣adding a component of information, education or entertainment

The customer is spared the additional work and the producer charges extra for adding value. Take

garlic, for example. Sold in bulk it brings \$4/lb. When braided, it may bring up to \$7/lb as a decorative item. Adding value holds the promise of additional income especially in the off season, but it is certainly more labor-intensive and requires more management, more investment in equipment, and an awareness of legal and regulatory issues pertaining to on-farm processing. Value-added products do not have the same economies of scale as mass-produced goods, and their success hinges heavily on the producer’s retail strategy, especially advertising and promotion.

An alternative agricultural specialty currently attracting a great deal of attention is agritourism. Although not every family is willing or able to entertain the public, for those who enjoy meeting new people or hosting groups, a farm entertainment enterprise is a good opportunity for selling on-farm processed items.

On-farm processors must be aware of regulations governing their enterprise. If a food product is being produced, usually a commercial kitchen is required. Specific regulations vary by state. A good overview may be found in a recent book by Neil Hamilton (see **Resources** section). Many farmers find it easier to lease space in an approved food processing facility, rather than spend the \$100,000 or more required to build and maintain a commercial kitchen on-farm. You should be aware that most states prohibit small children from entering a commercial kitchen, or anyone who is ill, or domestic meal preparation taking place there. A separate packaging facility may be needed. There are specific labeling requirements to be met, and additional regulations may apply in the case of interstate sales. Your state agriculture department and county health department are good places to start gathering information.

An organization that can provide information on developing food products is the Institute of Food Technologists (see **Resources**). In some places, governments, university centers or non-profit organizations (examples that come to mind are Minnesota's Agricultural Utilization Research Institute, the University of Nebraska's Food Processing Center, Iowa's Wallace Technology Transfer Foundation) assist rural micro-enterprise or other home-based food processing businesses in getting started. University food technology departments may be able to provide handbooks and guides for value-added food processing, technical assistance, and funding opportunities, as well as information on rules, responsibilities and marketing options.

Food processing incubators (FPI) have been a popular rural development strategy. FPIs, for a fee, provide commercial kitchen space and processing equipment, as well as technical assistance with product formulation and packaging. Some include peer group counseling to talk over manufacturing or marketing issues.

### **Arcata Economic Development Corporation**

☞ In Humboldt County, California, the Arcata Economic Development Corporation (AEDC) constructed the Foodworks Culinary Center to help develop micro industry in the region (23). The Center served as an incubator for 12 local gourmet and specialty food companies and includes 1000 sq. feet of shared commercial kitchen space in addition to each company's personal kitchen, 4000 sq. feet of warehouse space, and central office services.

Products being made by the companies include baklava, pastas, Finnish coffee bread, smoked salmon and garlic cream cheese spread, tofu products, ice-cream and toppings, jams, flavored honey and chocolate confections. Tenants have formed a marketing cooperative and a mail order catalog featuring the products was made available to promote them all across the country. For more information, call (707) 822-4616.

Little is known yet about the economic impact of FPIs, as they are a relatively new concept. Duncan Hilchey at Cornell's Farming Alternatives Program (see list of organizations under Resources) has conducted case studies of four incubators to get a better understanding of their working and impact. His findings are due to be published early in 2000. Advance copies may be requested. Meanwhile, those interested in exploring this subject further should get a copy of the publication called *Establishing a Share-Use Commercial Kitchen* from:

*Bob Horn*  
*Next Level Training Network*  
*University of Colorado at Denver*  
*Campus Box 128, PO Box 173364*  
*Denver, CO 80217-3364*  
*800-873-9378 (cost is \$58 plus \$4 s&h)*  
*(303) 556-6651 FAX*

Elizabeth Ryan, who sells a wide variety of value-added products — such as cider, fruit sauces, chutneys and salsa — at farmer's markets in and around New York City says that one way to make on-farm processed goods more profitable is to give farmers access to a commercial processing plant on a time-share basis. This kind of support has traditionally been unavailable to value-added enterprises.

Small farmers with specialty meat products have had particular difficulty finding and gaining access to USDA-certified processing plants. Arkansas-based graziers Lisa and David Reeves searched for three years to locate a good USDA-inspected facility to process their direct-marketed beef. Large processors, although certified by the USDA, will not differentiate between the small farmer's product and the large volume of meat they process and so are not a real option. (In other words, the farmer cannot retain ownership of the product.) USDA certification is mandatory for interstate sales and in states that lack an

#### **ATTRA's Value-added and Processing Series**

Overview: Adding Value to Farm Products  
Small-Scale Food Dehydration  
Grain Processing  
Small-Scale Oilseed Processing  
Soyfoods



inspection program (24).

### **Pricing and profitability**

If you don't have a percentage of people walking away from you at market, you're selling too cheap, says Tim Kornder, a farmer from Belle Plaine, Minnesota. Setting a price is one of the more challenging tasks faced by the direct

marketer. How does one know how much a pound of tomatoes or a head of lettuce is worth? On what information are these pricing decisions based?

In general, prices are set by production and marketing costs at the lower end, while the upper limit is set by what your customers are willing to pay, how much competition you have, and your own desired profits. It pays to figure your costs and set your prices accordingly, rather than just going by what others are charging; steady, consistent prices encourage steady, consistent customers.

Knowing your costs of production, both fixed and variable, is the first step in pricing strategy. Keeping good records for each item that you produce allows you to assess the profitability of each item in your product mix. Variable costs refer to costs directly associated with that item. These include costs such as field preparation and seed that will be there, even if nothing is harvested, as well as expenses directly related to yield such as harvest and packaging costs.

Fixed costs, or overhead, include costs such as loan repayments, property taxes, insurance, and depreciation and maintenance on buildings and equipment, which will be there even if nothing is grown. In addition, it is important to include some kind of wage or salary for yourself in your fixed costs. Don't forget marketing costs. It's usually easiest to include these in overhead. For the small producer, the biggest marketing cost is probably his or her time spent in finding and serving customers, doing promotions, making deliveries, and so on. Other costs could include advertising, free samples, and fuel and vehicle

upkeep. These fixed costs are allocated to each item you produce, perhaps by the percent of total

acreage or total production that each item accounts for. So if 10% of your land were in corn, then 10% of your total overhead would be included in the costs to produce that corn, for example.

### *Break-even analysis*

The break-even point refers to the price and quantity sold that will just cover all costs, leaving zero profit. At this price and sales level, while no profits are made, you won't be losing money. The break-even point is calculated as follows:

$$\begin{aligned} & \text{Sales Price} \times \text{Quantity Sold} \\ & = \text{Revenues} \\ & - \text{Variable Costs per unit} \times \text{Quantity Sold} \\ & = \text{Contribution Margin ("contribution} \\ & \quad \text{that the item makes to covering} \\ & \quad \text{fixed costs. This concept is useful} \\ & \quad \text{because it is often very difficult to} \\ & \quad \text{decide what part of fixed costs can be} \\ & \quad \text{assigned to a particular item. Rather} \\ & \quad \text{than trying to figure out that your} \\ & \quad \text{rutabaga crop accounts for 5\% of the} \\ & \quad \text{cost of your tractor, you can figure} \\ & \quad \text{out which items contribute the most} \\ & \quad \text{and plan your product mix accordingly).} \\ & - \text{Fixed Costs} \\ & = \text{Zero, or you can substitute a desired} \\ & \quad \text{profit margin, such as 5\% of sales.} \end{aligned}$$

Understanding this concept allows you to experiment with different combinations of prices and quantities, as well as different levels of variable and fixed costs, to assess potential profitability of various items. If you can't sell a product for more than cost, you had better not grow it in the first place. The new grower can start the educational process by studying wholesale prices and comparing those with retail rates at the store.

USDA's Agricultural Marketing Service publishes daily wholesale prices for produce, which may be accessed at <http://www.ams.gov/marketnews.htm>. Some growers call wholesalers for current prices; others check in with local chefs and local retail stores, especially on comparable specialty items. Wholesalers usually market up by 50%, while retailers mark

up by as much as 100%. This kind of information is useful in setting a realistic price for direct-

marketed products. Keep in mind, however, that stores sell “loss leaders,” items that are not marked up, which serve to draw in buyers.

How much would you have to sell to break even at these prices? What about at farmers’ market prices? Or you can start by estimating how much of each item you think you can sell, and then figuring what price you would need to break even. Is that price reasonable for the markets you plan to access? If the price is too high, how much would you have to reduce your costs or increase your sales in order to break even at a more reasonable price? If it appears that the break-even requirement is met, then you can begin figuring how high your prices can go. Again, base your estimates on research. For example, you could talk to growers at markets you won't be attending, so that they won't be giving information to a competitor. How much of each item do they sell over the season?

Cost-plus pricing is an easily used option. Once variable costs are figured per unit of the item produced, you just add a percentage of unit cost to the cost to get the price. That percentage should be enough to cover fixed costs and your desired profits. A 40% markup is about average for a direct marketer, although perishable items and items with higher storage costs are marked up higher (27). For more information and assistance with pricing, Extension and your local small business development center should be able to help.

Beginning lessons in pricing strategies are often best learned at farmers’ markets. Direct marketer Andy Lee says that he usually takes a quick walk around just before the market starts to note other displays and prices. Being the only organic grower at many of the markets he sells in, he marks his prices about 10% higher, especially if he sees that his products seem as good as or better than the others. Lee’s high prices may discourage some buyers but usually, he says, customers don’t complain once they taste the “delicious homegrown goodies” (17).

In one survey of 3000 customers, people were asked to rate the eight most important factors in their decision to buy sweet corn. Price ranked fifth behind freshness and other quality

considerations (25). Less than 15% of the sample thought price was a significant factor in purchasing corn. Roadstand growers who experimented with two piles of corn, one priced at \$3.50 and the other at \$3.00, found that the more expensively corn sold out faster than the cheaper corn. The reason may be that people assumed the higher-priced corn was fresher (25). The above experiment may have turned out the way it did because of the factors unique to corn, but it suggests that price may not be the only consideration for a prospective buyer.

Growers emphasize the importance of setting a price at the beginning of the season and holding on to it. Customary pricing, as it is called, compels the buyer to disregard price and base their purchase on other considerations. Laurie Todd, a small-scale grower based in New York, says that people will pay top dollar only if quality and service are guaranteed (26). To attract consumers, he suggests giving samples so that people can taste the product, using attractive displays and packaging, and emphasizing the product’s uniqueness. Like other growers, he does not recommend that you lower prices even when your competitors are reducing theirs. Full-time growers complain about hobby growers who don’t price realistically and virtually give away their produce for free. Many markets try to educate growers not to undercut the next person.

Growers who hold their price all season have the option of multiple-unit pricing to move extra

*Clearly marked prices are a must to let customers know exactly how much a grower is charging.*

volumes or attract buyers who want to buy in bulk for canning or freezing.

### **Mark Brown, Massachusetts**

☞ Mark Brown of Brown’s Provin Mountain Farm in Feeding Hills, Massachusetts, tries to set

retail prices twice as high as wholesale rates and says he likes to remain within “reasonable” range of store prices while making sure his production and sales costs are covered (27). In the event of lower prices, either from a sale or a

market glut, Brown prefers to retain his base price and add extra value to his product instead of reducing his price. So, when the competition is selling corn for \$2.75/dozen (0.23 cents an ear), Brown maintains his base price of 35 cents an ear and sells 6 ears for \$2 with a seventh tossed in for free, or \$3.75/dozen with two ears free. Brown finds that more people buy 14 ears for \$3.75, and he still makes 4 cents/ear more than his competitors.

Finally, this advice from growers:

- Don't sell your goods for a lower rate at the end of the day;
- Compete fairly on quality and service, never undercut;
- Don't badmouth other growers;
- Raise a good product and ask for a good price.

### *Direct marketing alternatives*

Ordinarily, retail markets command the highest price per pound of product, while wholesale markets move more of the product than retail markets but at lower prices. Farm sales and farmers' markets, You-Pick, mail-order are typically low-volume markets. Restaurants, retail stores, cafeterias, health food stores, and caterers constitute mid-volume markets, where prices are better than wholesale but on the lower end of retail. Smaller farmers may find that selling to low- and mid-volume markets works best for them. Mid-volume markets, especially, offer the advantage of small to medium crop production as well as medium to better prices (28).

Some direct marketing options are outlined here. State departments of agriculture or Cooperative Extension may have published guidebooks outlining the laws and regulations for direct marketing in the state. Check with local authorities before starting.

### *Organizing and selling at farmers' markets*

There has been an explosive growth in the number of farmers' markets around the country. In the mid-seventies, there were fewer than 300 markets in the United States. Two decades later,

there are more than 2,400 farmers' markets, with approximately 1 million people visiting them each week. The Madison, WI, farmers' market is first in the nation to have a website advertising the market. See <http://www.madisonfarmersmarket.com/>.

Several states have centralized information on farmers' markets, and a number of state-wide farmers' market associations have been formed. A comprehensive address list of farmers' markets is available on the Internet at <http://www.hort.purdue.edu/newcrop/FarmMARKET/FMIndex.html>. Guides for organizing and selling at farmers' markets are published by the Cooperative Extension Service in some states.

A publications list including direct marketing and other information published by the Hartford Food System may be requested (see **Resources**). A new publication offers guidance on selling local produce to school systems. Florida A&M University has initiated the "School Lunch Project" to assist small farmers in marketing to institutional food programs. A network of small farmers cooperatively produces and markets selected produce items to institutional buyers.

Many states offer help in promoting locally grown fruits and vegetables, sometimes with a special logo. City government, tourist departments and chambers of commerce can often be enlisted to help promote farmers' markets.

Farmers' markets seem to work best for growers who offer a wide variety of produce of the type desired by customers. Consumers want markets to be easily accessible with good parking facilities. A little related entertainment never seems to hurt—seasonal festivals, street musicians, tastings, demonstrations, etc. Sales help must be pleasant and courteous, willing to answer questions. Farmers interested in this marketing method can find opportunities for creative selling and fresh ideas through participating in the local farmers' market association and direct marketing meetings.

Additional information on farmers' markets is available from ATTRA.

### *Community Supported Agriculture (CSA)*

Community Supported Agriculture (CSA) plans operate in several different ways. One involves a single farmer selling "subscriptions" or "shares" at the beginning of the season and then

delivering, on a regular schedule, baskets of whatever is produced. Another method involves consumers who band together to rent land and hire a farmer to raise food for them. A new book, *Sharing the Harvest*, provides case histories, models, and strategies for starting a CSA (see **Resources**). The CSA of North America (see list of Associations) can provide more information on how CSAs work, including a video, *It's Not Just About Vegetables*, and accompanying handbook.

An e-mail networking list on CSA was started in February 1996 and subscription is free. To subscribe, send a message to:  
listproc@prairienet.org.

In the body of the message, type subscribe csa-l followed by your first name and your last name.

For an overview of Community Supported Agriculture, ask for ATTRA's publication on CSAs.

### *On-farm sales and agri-tourism*

On-farm sales include pick-your-own (P-Y-O) and roadside stands or farm markets. Pick-your-own began in response to the 1974 energy crisis, appealing to customers (mainly families) who had the time and the necessary expertise to process their own foods in quantity. More recently, PYO enterprises have been integrated into the growing "farm entertainment" sector.

Marketing strategies may include educational tours, an on-farm market with opportunities to buy fresh produce or value-added products, ready-to-eat food, festivals, classes, seasonal events such as a personalized pumpkin patch, or agricultural mazes. A buffalo ranch, besides selling hides and meat, charges admission to view the animals.

### **The Rombach Farm, Chesterfield, MO**

Beginning each July, the Rombach Farm becomes a pumpkin wonderland. From late September on, partner Steve Rombach works 7 days a week. Besides pumpkins, apples, and squash, the farm market sells sweet corn (in season) and other vegetables, handcrafted yard furniture, and yard ornaments. Most of the family's remaining 700 acres (100 acres have been lost to development) remain in soybeans and wheat. The biggest profit, however, is from farm stand sales.

Many of the pumpkins are raised on the farm, rotated with wheat. Rombach is thinking of strip cropping pumpkins with wheat, however (because the wheat is not ready when pumpkins must be planted). He uses one field near the house as a display area after the wheat is harvested. The mid-size 20-lb. pumpkin is his best seller, but bigger ones are popular. Few are bought for pie-making. Those left unsold after Thanksgiving are composted in the woods, where wildlife enjoy them. The bulk market for canning does not exist here.

Besides family labor, Rombach hires a lot of part-time help and depends on good friends to volunteer in creating seasonal displays. These elaborate displays are extremely creative and colorful—employing small buildings, 10-ft. high mounds of pumpkins, and Halloween figures. They attract up to 1000 cars a day at the peak of the season. They are not dismantled until the final two weeks "because so many schools come." Backdrops are corn shocks or castor bean plants. Rombach is now looking into offering hayrides.

Insurance is high. The farm carries 5-6 policies, including an umbrella liability policy. Many repairs, seed orders, fertilizer, etc. are undertaken in the off season.

The Rombach farm has been totally rebuilt since 1993, when Missouri River flooding put it under seven feet of water. Initially, the farm enterprises included Christmas tree sales, and acres of U-pick strawberries. But Rombach says they lost money on the trees and PYO customers "trampled too much." Children would throw the berries

around. He now does retail sales only. (A few items offered at the farm market are procured from other farmers.)

Rombach's grandfather started hosting parties in the pavillion in 1928; his parents began the retail sales. Steve Rombach, his brother, and a cousin incorporated in 1993, the year they rebuilt by starting the pumpkin venture. Rombach's father, who is retired, now works for him. Mrs. Rombach works off the farm (29).

Such enterprises work best when farms are within thirty miles of a major population center, preferably on or near a good road. Pick-your-own is most adapted to crops which require stoop labor to harvest. Plans and layout for farm markets are published in the NRAES booklet *Facilities for Roadside Markets*, available from Cornell and in *Bypassing the Middleman*, from Rodale Press (see **Resources**).

In addition to the expected parking, restrooms, harvesting instructions, creative signage, and playgrounds, adequate liability insurance must, of course, be in place.

Direct marketers can get liability insurance through the North American Farmers' Direct Marketing Association (NAFDMA) (30). Comprehensive information on legal issues for all types of direct marketing is available in *The Legal Guide for Direct Farm Marketing* (1999) by Neil Hamilton (see **Resources**).

In some areas of the country, fee hunting is combined with farming. One Nebraska farmer combines fee hunting with hunting lodge accommodations (and a gift shop) during the slow winter season on his 1500-acre grain farm. A publication of interest is *Agritourism in New York:*

*Opportunities and Challenges in Farm-Based Recreation and Hospitality*, available from Cornell Media Services at Cornell University (607-255-2080) for \$13.85. (This publication is currently being reprinted.) For more information, ask for ATTRA's publication *Pick-Your-Own and Agri-Entertainment*.

### *Selling to restaurants and stores*

According to some reports, over 50% of American meals are now eaten away from home. This would appear to be a growing market for direct sales of produce. However, most high-volume meal servers (institutional food service and restaurant chains) require huge volumes, typically procured through centralized purchasing. It is still possible, however, to find

an individually operated restaurant buying some foods locally. High quality is a prime requisite for sales to such restaurants. Such specialty crops as herbs, garlic, mushrooms, salad greens, cut flowers, and edible flowers for restaurants may be grown on very small parcels of land. One of the main requirements for selling to an upscale restaurant seems to be developing a good relationship with the chef.

In some instances sales by local farmers to local institutions may be arranged. The Hartford Food Project (see list of organizations) has a publication describing creation of such marketing channels.

ATTRA has some additional information on marketing to restaurants and specialty stores.

### *Mail order and home delivery*

Mail order sales generally involve value-added products or (primarily in Florida and the West Coast) fresh fruits. Value-added products are often decorative, rather than culinary. Home delivery of fresh farm products was much more common in the U.S. fifty years ago than it is today. The sight of a horse-drawn farm wagon loaded with bushels of apples, squash, potatoes, and live chickens making its way slowly through a residential neighborhood while the farmer (or his children) knocked on doors was not unusual. But it is still possible for farmers to meet consumers at the doorstep and deliver quality

food. This method is currently most used by dairy and meat producers. Nowadays arrangements are made in advance by telephone and meats are usually frozen. Some CSAs home deliver.

## Marketing on the Internet

Plans for selling groceries on the Internet are taking their place along with other forms of e-commerce. Most such plans ask the consumer to pick up an

*Harps Supermarket, Fayetteville, AR, has joined the ValuPage website offering Web Bucks to customers who print out coupons from the web page and purchase certain products. Web Bucks may then be used to buy anything else in the store. This is a premium for customers to visit the website. See <http://www.valupage.com>. Customers may also sign up for regular e-mailed coupons.*

Internet order at their local supermarket.

High-value, nonperishable, low-weight, specialty food products and nutritional supplements have

been available from a growing number of websites for some time. Delivery is by conventional package delivery systems; this form of e-commerce may be considered another another form of mail-order.

Another way to utilize the WWW is to have a farm or business homepage purely for advertising purposes (perhaps cooperatively packaged). Examples include the Madison, WI, farmers market website mentioned previously and the Virtual Virginia Agricultural Community, at: <http://www.vvac.org>, which facilitates regional communication. The Minnesota Land Stewardship Project's on-line directory of CSA farms (with e-mail and website contacts) is at <http://www.misa.umn.edu/lsp.html>.

According to Jennifer-Claire V. Klotz (USDA/AMS), who spoke at the October 1999 National Small Farms Conference in St. Louis, 92 million potential customers are now on the Internet, one-third of them making purchases.

Internet users tend to be older, with above-average educations and higher incomes. Interestingly,

Internet users share these characteristics with direct market customers in general.

Farms can do business on the Internet either by maintaining their own individual websites, or participating in a directory listing. Research providers and costs; look at bartering to get a website designed. Look at Internet marketing as an opportunity to attract a new clientele, but first determine whether existing customers are on the Internet. Do they have e-mail? Be aware of certain barriers to Internet buying:

- pricing (include shipping costs)
- potential return hassles
- credit card concerns of customers
- privacy issues
- navigating the site

Do everything possible to show you are honest and reputable. Do not sell or lease e-mail addresses. Have a privacy statement that you won't sell customer information.

Customers like a website that is easy to use, quick to download, and updated frequently. Be cautious about graphics that take a long time to come up on screen. At least give customers the option to bypass graphics.

Look into ways to increase search engine results for your site, so that it appears in the first five or ten that come up. (There is a way to bid on "ebay" to get you into the top 5.)

Klotz advises that existing customers (for example, at your farmers' market) should be approached slowly for information for your database. Remember that "customers are selfish and there is a lot of competition on the Net." Invite people to your website; don't ask for the customer's e-mail addresses right away. Have a prize lottery to get customers' names and addresses for your mailing list. Or have on-line coupons they can print out (10% off, etc.). Then ask for their e-mail address so they can receive your newsletter.

With another individual or business website, offer something if they put in a link. Call the local press (Food or Business section, not Agriculture), and offer an interview.

Put your web address everywhere – on all stationery and items that go out. Offer freebies (samples) when filling orders. Have a raffle. Develop a kids e-mail mailing list and send birthday cards. Send fall holiday greetings. List your competitors' prices (shown to be effective). Bid on words for headings (eBay, etc.) to make the top five results from browsers. Make your website interesting. When creating your web page, call the first page "index" to aid search engines.

Constantly test and evaluate your site.

### **Promotion and publicity**

Associations such as the Organic Trade Association (OTA) help promote members through materials and a calendar of events.

Promotions help to increase sales per customer and the number of clients, and enhance the image and visibility of the farm, company and/or product. For an overview of promotion strategies and advertising, refer to *Sell What You Sow!*, *The New Farmers' Markets* and Extension publications such as the Pacific Northwest Cooperative Extension series *Farmer-to-Consumer Marketing* (especially no. 3., *Pricing and Promotional Strategies*) (see **Resources**). Promotions come in different shapes and sizes but they all have some common characteristics.

- ♣ They draw attention and communicate information;
- ♣ They provide an incentive or premium to the consumer;
- ♣ They invite the consumer to buy.

Word-of-mouth advertising by satisfied customers is priceless and cannot be purchased or engineered except by providing good service and a good product. Because an estimated 80% of business comes from return buyers, the focus is on rewarding loyal customers by offering discounts, gift certificates or a free service.

Coverage by the local newspaper or radio/television station can bring in more sales than any paid advertisement. Events on the farm – a Halloween festival for children,

### **Some Home Pages for U.S. Farms**

Claymont Court, Shepherdstown, WV  
<http://www.claymont.org>

Cromwell Valley CSA  
<http://www.earthome.org>

Earthlands North Quabbin Farm  
<http://www.tiac.net/users/elandspc/>

Eco Farms, Lanham, MD  
<http://www.ecofarms.com>

Glen Oshira, Hawaii  
<http://www.smallfarms.com>

Howell Farm, Titusville, NJ  
<http://www.americanmaze.com/PR98Howell.htm>

Massachusetts Farm Directory  
<http://www.massgown.org>  
<http://www.massgown.org/youpick.com>

Peacework Organic Farm, Newark, NY  
<http://www.gvoca.org>

Three Sisters Farm, Sandy Lake, PA  
<http://www.bioshelter.com>

Dog Wood Knob Farm, Mt. Vernon, KY  
<http://www.geocities.com/RainForest/8450/>

Mountain Gardens, Burnsville, NC 28714  
<http://gardens.webjump.com>

Tate Family Farm/Goat Lady Dairy  
 Climax, NC  
<http://www.goatladydairy.com>

Wollam Gardens, Jeffersonton, VA 22724  
<http://www.wollamgardens.com>

Angelic Organics, Caledonia, IL 61011  
<http://www.AngelicOrganics.com>

Elixir Farm, Brixey, MO  
<http://www.elixirfarm.com>

Inn Serendipity, Browntown, WI 53522  
<http://members.aol.com/innseren/public/innserendipity.html>

Susan's Garden, Plattsburg, MO  
<http://ianwhite.stanford.edu/susangarden/>

Camas Meadow Farm, Noti, OR  
<http://members.aol.com/camasfarm/>

Emandal, Willits, CA  
<http://emandal.com>

availability of a new and unusual food item, a cider-tasting contest – may lure reporters in search of human-interest or weekend-event

stories. Invite the local newspaper's food editor over for a dinner of grass-fed beef, or pastured chicken so she or he can taste the difference from supermarket fare. While writing up a press release, look for the news peg that makes the

story – an accomplishment, an award, anything that seems interesting or valuable to the community. Give the press plenty of notice, good photo opportunities, and always return phone calls.

Paid advertising is the non-personal promotion of an idea, product or service directed at a mass audience. Its aim is to generate an increase in sales, induce brand recognition and reinforce the "unique selling point," inform potential customers about the availability of a product, and create demand for that product. An advertisement should emphasize benefits, not objects. What will people get from your product or from a visit to your farm? High-quality, fresh, delicious produce or meat? Family fun? Friendly service? You can either advertise continuously through the season to maintain your presence in the marketplace, or you can advertise just before a product is available.

Advertising budgets generally range between 4 and 10 percent of sales. Let's say you rely heavily on radio spots for continual advertising during the six months you are open (31). If projected sales are \$50,000 and you commit 4% to the advertising budget, this means you have \$2,000. If 60% of this is allocated to continual advertising through the 6-month marketing season, you have \$1,200 for that period. The balance of \$800 would be allocated to each of those months depending on the percentage of seasonal sales that occurs in that month. If 50% of sales occur in July, then \$400 would be allocated to that month over and above the base budget for April. This amount can be used for other forms of promotion such as direct mailings, or newspaper ads. If competition is high, ad budgets may need to increase. Re-evaluate an ad campaign if it does not bring about a quick increase in sales.

Attractive road signs are another effective form of advertising. Signs that are legible to the speeding

motorist are a way to induce people to stop and visit the roadside market or farm-stand. Signs should have a logo and should reflect the kind of goods being sold—more upscale if they are high-priced and a 'no-frills' sign if otherwise. Signs that advertise an unusual or out-of-the ordinary product will draw the curious to the farm. The first sign should be placed a good distance (at

least 2500 feet) before the market to give the motorist time to decide whether or not to stop. Keep signs neat and well-maintained.

Direct mail is advertising with a personal touch and requires an up-to-date and extensive mailing list. Postcards with pictures of your farm, a logo and a promotional message may be sent just before a farm festival or when produce is available. Direct mailing is only as effective as its mailing list (i.e. its targeting of people who will buy your product).

Mailing lists should be revised each year. Target groups of people likely to buy your product (e.g., members of a health food store or co-op). A mailing list can be developed by asking people to sign up for mailings. Also, ask them where they heard about your product or farm. This information will help you plan future advertising.

### **Peggy Frederick, Whitney Point, NY**

☞ Peggy Frederick of Strawberry Valley Farm in Whitney Point, New York, mails customers a specially-designed card listing the vegetables and strawberries available for U-pick. For Christmas, she sends out the "giftbox" brochure which lists gift items from the farm's bakery and consignment gift shop.

### **Ellie MacDougall, Maine**

☞ *In her catalog, Ellie MacDougall, a Maine-based grower, inserts a little promotional mailing on behalf of a local turkey grower, who in turn sells her poultry and turkey stuffing seasonings (32). Many of her seasonings and*



*vinegars are cross-sold by produce growers at other markets and farm stands.*

The catalog is a marketing tool that serves many purposes. Common elements of a catalog are (33):

- ✓ It should *tell a story*. It should differentiate your business from others and explain why and how you are different.
- ✓ It should *work like a reference*, providing detailed information about the product, service and business.
- ✓ It should *be a sales tool*. In addition to providing information, it must promote your product, service and business.
- ✓ It should *create a good first impression*.

Business cards have a way of sticking around in people's wallets long after they have been distributed. Print and hand out business cards with your name, phone number, farm location and product.

The Internet offers a whole new world of marketing opportunities. Its key features are 24-hour accessibility by anyone with Internet capabilities and greatly expanded reach without the costs and limitations of direct mail. Customers may be able to place an order on line, but the chief value is the publicity an attractive website can bring to a producer. Another advantage is making your on-line catalog available to Internet users.

The first North American Agricultural Internet Marketing Conference "Internet Goes Ag, Making it Work For You!" was held in October 1996, in Chicago. An excellent source of information and current resources is the Washington State University Extension (King County) publication *Internet Marketing for Farmers* (available on-line at <http://king.wsu.edu/Ag/internetmarketing.htm>). More information on

e-commerce is available from USDA's Small Farm Center (see **Resources**).

### **Papa Geno's Herbs, Lincoln, NE**

☞ Within six months of setting up a Web page and beginning an e-mail newsletter, Gene Gage

of Papa Geno's Herbs found that plant orders from the Internet had surpassed those from his traditional mail-order catalog (34). Size of the average order through the Internet was higher. Gage sends his e-mail newsletter out 15 times a year. Advertising on e-mail is cheaper, he says. It would cost him 50 cents to send a post card to each customer. Direct mailings to 40,000 people would cost him \$20,000. The same people,

assuming they had access to a computer, could be reached by e-mail for \$5. Each day he receives 100 messages via e-mail. These are in addition to the orders that an employee takes in from her home. The hard work involves spending 20-40 hours a week online, for business and "schmoozing." Gage is constantly on the lookout for links to add to his web page and spends hours giving advice free of charge as resident herb expert of America Online and the gardening site Garden Escape. One disadvantage is that he has had several bad checks from Internet customers, a problem he has never had to face in retail and paper catalog sales.

A lively and regular newsletter, written in the first person, discussing upcoming produce, recipes, farm events and life on the farm, makes the reader feel more involved and connected. Ideas for content may come from customers or from employees.

### **Flickerville Mountain Farm and Groundhog Ranch, Flickerville, PA**

☞ Cass Peterson and her late husband, Ward Sinclair, who farmed with great flair and ingenuity for several years, published an annual newsletter for subscribers to their CSA called *The Groundhog Report*. With just the right touch of wry humor, the publication put together by the former *Washington Post* reporters informed consumers about prices and included tips on cooking vegetables, news from the farm, and quotable quotes.

When creating a newsletter, consider the following (35):

- ☞ What items do you want to promote?
- ☞ What should you say to induce readers to buy?

- ☛ Are readers made to feel included and important?
- ☛ Have necessary details such as farm hours, phone number, deadlines, etc. been included?
- ☛ Is the newsletter uncluttered and visually pleasing?

Including a map of how to get to the farm is always helpful. Newsletters may also be sent to the news media or published as an insert in the regional newspapers.

## Angelic Organics, Caledonia, IL

☛ Kimberly Rector, formerly of Angelic Organics, a biodynamic farm northwest of Chicago used packaging to promote and educate people about the product (36). An artist by training, Rector chanced upon a motif for the farm, and used it on specially crafted paper labels with the farm logo and information about the product, on packaging for specialty items such as herbs, on signs designed for the farm stand and at the farmers' markets, and on specially-designed point of purchase posters. That increased demand for produce. Rector recommends retail packaging as a plus for farmers' markets and sales to stores.

Single event promotions like harvest festivals, Easter egg hunts, and Halloween costume contests can be combined with ongoing promotions like school tours or Friday happy hours or open house. Publicize the promotions well ahead to ensure a good turnout.

## Lost Nation Orchard and Cider Mill

☛ The Lost Nation Orchard and Cider Mill is a good example of the use of a mix of sales strategies. In addition to creating a striking cider label with a logo to enhance their presence on store shelves, partners Michael Phillips and David Craxton promote Lost

Nation as a community farm (37). People trade labor for cider, helping to pick wild apples, label jugs or dig planting holes for new orchards. Phillips and Craxton write occasional press releases promoting apple tastings and harvest festivals, or providing early-season tips

to growers. They also run ads regularly in these newspapers. The format generally remains the same, but photographs and text may vary. Advertising budgets average 5% of gross receipts. The idea behind their marketing strategy is to promote the experience of authentic country life, its fun and friendliness and generosity of spirit, in their advertisements, their brochures, at their annual harvest festival, at the school tours hosted on Friday mornings,

and on the Lost Nation trading cards - educational cards with a little snippet of information that is handed to the consumer with each purchase. All in all, it makes for a wonderful tourist experience. The ideas, the insight and the creativity behind the marketing package, says Phillips, happened only because they loved and believed in what they were doing.

## Conclusion

Finally, some parting advice to people considering direct marketing or processing of farm products. First of all, do something you love and enjoy doing. Success will follow. Invest time and, if necessary, money in research. Try to have a well-considered plan before proceeding but don't be rigid. Learn as you go. Start small and keep your costs and debt as low as possible. Provide a reliable supply of high quality products and build a good relationship with your customers. Take time to listen to their wants, identify market possibilities, and find a unique market niche for your product. Be adaptable to shifting market opportunities. Ensure diverse markets, so that if one fails, you can fall back on the others. Set a fair price and avoid competing directly with big business, especially on price.

## References:

1. Thompson, Allen R. 1980. Marketing and the Small Farmer. The National Rural Center, 1828 L Street NW, Washington, DC. p. 4.
2. Thompson, Allen R. 1980. Marketing and the Small Farmer. The National Rural Center, 1828 L Street NW, Washington, DC. p. 7.

3. Martinez, Steve W., and Al Reed. 1996. From farmer to consumers: Vertical coordination in the food industry. U.S. Department of Agriculture Economic Research Service Report. Agriculture Information Bulletin Number 720. June.
4. Staff. 1999. [news item.] Pork. April .p. 54.
5. Thompson, Allen R. 1980. Marketing and the Small Farmer. The National Rural Center, 1828 L Street NW, Washington, DC. p. 12.

### References:(continued)

6. Nothdurft, William E. 1986. Going to Market: The New Aggressiveness in State Domestic Agricultural Marketing. Council for State Policy and Planning Agencies, Washington, D.C. p. 12.
7. Gibson, Eric. 1994. Sell What You Sow! The Grower's Guide to Successful Produce Marketing. New World Publishing, Carmichael, California. p. 17.
8. Hall, Charles R. et al. No date. A Guide to Marketing Organic Produce. Texas Ag. Extension Service. Varied paging.
9. Schermerhorn, R.W. 1991. Is Your Agribusiness Project Feasible? University of Georgia Cooperative Extension, Athens, GA. 15 p. AT: <http://www.ces.uga.edu/pubed/b1066-w.html>
10. Gilbert, Linda. 1998. Tracking 1998's top trends. Natural Foods Merchandiser. January. p. 41, 48, 50.
11. Staff of *The Packer*. 1999. Fresh Trends: A 1999 Profile of the Fresh Produce Consumer. p. 4, 14.
12. Rocky Mountain Institute (ed.) 1987. "Marketing" How To Survive As A Small Farmer. RMI, Snowmass, Colorado. p. 17.
13. Bjergo, Alan. 1986. Marketing: Why Have a Marketing Plan? University of Montana Coop Extension Service, Missoula, MT. 10 p.
14. J.E. 1997. Marketing ideas for small farmers. Maine Organic Farmer & Gardener. June-August. p. 18.
15. McConnon, James C. 1996. "Surviving in a world of mass retailers." p. 142. In: Proceedings 1996 North American Farmers' Direct Marketing Conference. February 22-24, 1996. Saratoga Springs, New York.
16. Caplan, Frieda. 1997. Specialty crops spelled out. Small Farm News. April-May. p.1.
17. Lee, Andy. 1993. Backyard Market Gardening: The Entrepreneur's Guide to Selling What You Grow. Good Earth Publications. p. 4.
18. Bala, Radhika. 1998. Unpublished paper. Fayetteville, AR.
19. Byczynski, Lynn. 1997. Peppers are hot on Pennsylvania farm. Growing For Market. January. p 10.
20. Steve Salt  
Green Valley Farm  
RR 1, Box 263  
Kirksville, MO 63501-9734  
e-mail: saltsgvf@istlaplata.net
21. Salt, Steve. 1997. Growing for the cuisines of other countries sustains this family farm, even in a rural area. Growing For Market. June. p. 8.
22. Richards, Keith and Wechsler, Deborah S. 1996. Making It On The Farm. Increasing Sustainability Through Value-Added Processing and Marketing. Southern Sustainable Agriculture Working Group. p.2.
23. Anon. 1994. Moving start-ups out of the kitchen. In Business. March/April. p. 25.
24. O'Neill, Kelly. 1997. Emerging Markets for Family Farms. Center for Rural Affairs, Walthill, Nebraska. p. 9.
25. Anon. 1994. Lessons from the big retailers. (Reprinted from Cornell Small Fruits Newsletter, Oct. 11, 1993) Vegetable Notes, October. p. 1. Another perspective on marketing. (Reprinted from Cornell Small Fruits Newsletter, Oct. 11, 1993) October. p. 2.
26. Todd, Laurie. 1996. "The reality of establishing prices." p. 153. In: Proceedings 1996 North American Farmers' Direct Marketing Conference. February 22-24, 1996. Saratoga Springs, New York.
27. Brown, Mark G. 1996. Setting prices for a farmers' market. Proceedings 1996 North American Farmers' Direct Marketing Conference. February 22-24. p. 155.

28. Warr, A.M. 1993. Basil, Chives, Parsley...Idea Sheet: Farming and Farm-Related Business Ideas. Skylands Small Business Development Center at Warren County Community College. 2 p.
29. From talk delivered by Steve Rombach on October 14, 1999, at Rombach Farm to touring participants in the 2<sup>nd</sup> National Small Farms Conference, St. Louis, MO.  
Notes taken by Katherine Adam.
30. NAFDMA  
62 White Loaf Road  
Southampton, MA 01073  
(413) 529-0386  
(888) 884-9270  
<http://www.nafdma.com>
31. Ashley, Richard A. 1995. Planning your advertising campaign. Yankee Nursery Quarterly. Spring. p. 11.
32. MacDougall, Ellie. 1995. Expand your business by cross-selling. Growing For Market. May. p. 6.
33. McCoy, Miles and Laurent, Carla. No date. Produce a Catalog For a Reasonable Investment. Pimento Marketing, West Linn, Oregon. 503-657-7550. Also see  
<http://www.plantzone.com/articles/catalog.html>
34. Byczynski, Lynn. 1997. Herb plant business thrives on the Internet. Growing For Market. November. p. 8-10.
35. Frederick, Peggy. 1996. "Newsletters to encourage customer loyalty." p. 124. In: Proceedings 1996 North American Farmers' Direct Marketing Conference. February 22-24, 1996. Saratoga Springs, New York.
36. Byczynski, Lynn. 1995. Artistic farmers find an appreciative audience. Growing For Market. April. p. 10
37. Phillips, Michael. 1995. Light-hearted marketing helps orchard thrive. Growing For Market. August. p. 9.

The electronic version of Direct Marketing is located at:  
<http://www.attra.org/attra-pub/directmkt.html>

---

**By Katherine Adam, Radhika  
Balasubrahmanyam, and Holly Born  
NCAT Agriculture Specialists**

---

**November 1999**

The ATTRA Project is operated by the National Center for Appropriate Technology under a grant from the Rural Business-Cooperative Service, U.S. Department of Agriculture. These organizations do not recommend or endorse products, companies, or individuals. ATTRA is located in the Ozark Mountains at the University of Arkansas in Fayetteville at P.O. Box 3657, Fayetteville, AR 72702. ATTRA staff members prefer to receive requests for information about sustainable agriculture via the toll-free number 800-346-9140.





[www.attra.ncat.org](http://www.attra.ncat.org)

# DIRECT MARKETING: RESOURCES

**BUSINESS MANAGEMENT SERIES**

ATTRA is the national sustainable agriculture information center funded by the USDA's Rural Business -- Cooperative Service.

*Sustainable Farming programs, such as those as Cornell University and the University of California, are often the best sources of recently published guides, as are private initiatives such as the Hartford Food Project. Increasingly, such information is most easily accessed through the Internet. Extension personnel in several states say that all their current publications are listed (and should be accessed) on their websites, as did other organizations.*

*For out-of-print Extension publications, a U.S. Government Documents repository (generally located at a major landgrant university) or private library may provide access.*

*Publications which inform small farmers and specialty growers on direct marketing options include The Business of Herbs, Small Farm Today, Growing for Market, and the new electronic publication Sustainable Farming Connection at <http://sunsite.unc.edu/farming-connection>.*

*A variety of conferences on marketing and agriculture are held every year around the country. The largest is the national North American Farmers' Direct Marketing conference held at the beginning of each year. The Year 2000 conference will be held on February 10-12 Cincinnati, OH. For information on conferences or proceedings, contact Vicki Parker-Clark at (208) 667-6426. (There is no conference website this year.) Information on the annual Mid-Atlantic Direct Marketing Conference, usually held in mid February, may be obtained from Dr. Ramu Govindasamy at Rutgers Coop Extension at 732-932-9171, ext. 25.*

## Publications

Beck-Chenowith, Herman. No date. Free-range Poultry Production & Marketing. [3-ring binder]. Back Forty Books, Creola, OH. 120 p.  
Order for \$39.50 + \$4.50 s/h from Back Forty Books, 26328 Locust Grove Road, Creola, OH 45622. Call (740) 596-4379 for information about short courses for farmers.

Byczynski, Lynn. 1997. The Flower Farmer; An Organic Grower's Guide to Raising and Selling Cut Flowers. Chelsea Green Publications, VT. Chelsea Green Publications, VT.  
P.O. Box 428  
205 Gates Briggs Bldg.  
River Junction, VT 05001.  
800-639-4099

Campidonica, Mark. 1997. How to Find Agricultural Information on the Internet. Publication 3387. University of California.

*Walks readers through real life examples of how farmers and others have used e-mail and the Internet to improve their business. Available for \$15 ppd from:*  
UC DANR Communication Services  
6701 San Pablo Avenue  
Oakland, CA 94608-1239  
800-994-8849 or 510-642-2431  
Internet address is [www.sarep.ucdavis.edu/](http://www.sarep.ucdavis.edu/)

CAPAP (ed.). 1990. The Alternative Field Crops Manual. Center for Alternative Animal and Plant products, Minnesota.  
*Provides information on the production of many minor or new field crops. Costs \$45. Also available is the Alternative Agricultural Opportunities, a bibliography listing over 1600 articles on alternative plants and animals. Cost is \$5. Contact:*

CAPAP  
352 Alderman Hall  
1970 Folwell Avenue  
St. Paul, MN 55108.  
612-625-4707; FAX 612-625-4237  
<http://capap.coafes.umn.edu>

## Publications: (continued)

---

Desai, Mihir. 1994. The U.S. Market For Miscellaneous Oriental Vegetables. A Lac Tech Report, U.S. Agency for International Development, Washington, D.C. 20523. Available free from USAID.

Economic Research Service (ERS) ed. No date. Agricultural Research and Development, Public and Private Investments Under Alternative Markets and Institutions. AER-735. ERS-NASS, Virginia. (703) 605-6900. A copy may be obtained by sending a check or money order for \$29.50 to: ERS-NASS  
5285 Port Royal Road  
Springfield VA 22161  
800-999-6779  
See publication at [www.econ.ag.gov/](http://www.econ.ag.gov/)  
Order from [ers.nass@ntis.fedworld.gov](mailto:ers.nass@ntis.fedworld.gov)

Engel, Allison and Engel, Margaret. 1991. Food Finds – America's Best Local Foods and the People Who Produce Them. Harper Perennial, New York, NY. 346 p.

Gibson, Eric. 2000 [in press]. The New Farmers Markets. New World Publishing, Vista, CA.

Gibson, Eric. 1996. Farmers Markets 96: The What's Hot/What's Not Guide for Growers and Managers. New World Publishing, Vista, CA. 12 p.  
*Interviews with market managers and vendors from around the country. Available for \$5 from:*  
New World Publishing  
3037 Grass Valley Highway #8185  
Auburn CA 95602  
916-823-3886

Gibson, Eric. 1994. Sell What You Sow! The Grower's Guide to Successful Produce Marketing. 302 p. Available for \$25.50 from New World Publishing (see above address).

Gregson, Bob and Gregson, Bonnie. 1996. Rebirth of the Small Family Farm. IMF Associates, WA. 65 p.  
*The book focuses on what to grow and how to sell it. Available for \$9.95 (\$10.65 for WA residents) from:*  
IMF Associates  
PO Box 2542  
Vashon Island, WA 98070.

Growing For Market (ed.) Marketing Your Produce: Ideas For Small-Scale Farmers.  
*Fairplain Publications*  
P.O. Box 365  
Auburn, KS 66402.

Grubinger, Vernon. 1999. Sustainable Vegetable Production from Start-Up to Market. NRAES. Cornell Cooperative Extension, Ithaca, NY. \$49.85.

Hakenson, Dan. 1995. The Small Commercial Garden: How to Make \$10,000 A Year In Your Backyard. 198 p. Send \$20.90 (ND residents \$20.98) to:  
*PC-Services*  
PO Box 7294  
Bismarck, ND 58507-7294.  
800-871-4296.

Hall, Charles R. And Johnson, Jeff L. 1992. A Guide To Successful Direct Marketing. Texas Agricultural Extension Service, Texas A&M University, College Station, Texas. 32 p.  
*Send \$12 by check payable to:*  
*Account 5500 Texas Extension Education Foundation*  
*Attn: Charles Hall*  
*464 Blocker Building*  
*College Station, TX 77843-2124*  
*409-845-1772*

Hall, Stephen F. From Kitchen to Market; Selling Your Gourmet Food Specialty. Upstart Publishing. Available for \$24.95 from:  
*Upstart Publishing*  
*155 N. Wacker,*  
*Chicago, IL 60606.*  
*800-235-8866.*

Hamilton, Neil D. 1999. The Legal Guide for Direct Farm Marketing. USDA/SARE grant. 235 p.  
*Order for \$20.00 from:*  
*Agricultural Law Center*  
*Drake University*  
**Des Moines, IA 50311**  
*515-271-2947*

Henderson, Elizabeth with Robyn Van En. 1999. Sharing the Harvest: A Guide to Community Supported Agriculture. Chelsea Green Publishing, White River Junction, VT. \$25.00.

*Order from Chelsea Green Publ., 205 Gates-Briggs Bldg., P.O. Box 428, White River Junction, VT 05001. (800) 639-4099*  
<http://www.chelseagreen.com>

## Publications: (continued)

- Ishee, Jeff. 1997. *Dynamic Farmers' Marketing*. Bittersweet Farmstead, 130 p. *Bittersweet Farmstead*  
P.O. Box 52  
Middlebrook, VA 24459  
*Describes how family farmers can make the best of the explosive growth in farmers' markets. Copies may be obtained by calling 540-886-8477. Send 14.95 plus \$2.50 shipping and handling.*
- Island Meadow Farm (ed.) *Fifty Small Farm Ideas*. Send \$3.75 to:  
*Island Meadow Farm*  
295 Sharpe Road  
*Anacortes-Fidalgo Island, Washington, 98221.*
- Jenkins, R.P. 1991. *Establishing and Operating A Farmers' Market: A Manual for Sponsors, Boards of Directors, and Managers of Farmers' Markets*. University of Tennessee Agricultural Extension Service. 24 p.  
Order as Pub. 847 from:  
Wanda Russell, Co-op Ext.  
(423) 974-7360
- Jozwik, Francis X. *How To Make Money Growing Plants, Trees and Flowers: A Guide to Profitable Earth-Friendly Ventures*. Andmar Press. 180 p. *Andmar Press*  
P.O. Box 217  
Mills, WY 82644.  
*Also by the same author:*  
*Perennials For Profit or Pleasure: How To Grow and Sell in Your Own Backyard*. 80 p.
- Kamoroff, Bernard. 1992. *Small-Time Operator: How to Start Your Own Small Business, Keep Your Books, Pay Your Taxes and Stay Out of Trouble!* Bell Springs Publishing, Laytonville, CA 95454. 188 p.
- Larkin, Geraldine A. 1992. *12 Simple Steps to a Winning Marketing Plan*. Probus Publishing Co., Chicago, IL. 217 p.
- Lee, Andy. 1993. *Backyard Market Gardening: The Entrepreneur's Guide to Selling What You Grow*. Good Earth Publications. 351 p.  
*Good Earth Publications*  
P.O. Box 898  
Burlington VT 05482  
*Practical guide on growing food for income. Describes membership gardens, CSA, growing for restaurants, producers' cooperatives, farmers' market etc. To order call 802-425-3201 or e-mail goodearth@igc.apc.org.*
- Makus, L.D. et al. 1993. *Planning Your Business*. CIS 978. University of Idaho, Coop. Extension System. Ord. #422 Available for 50 cents from:  
*Ag. Publications*  
*Idaho Street*  
*University of Idaho*  
*Moscow, ID 83844-2240.*  
208-885-7982.  
<http://info.ag.uidaho.edu/catalog/Catalog.html>
- Also available are:*
- Makus, L.D., J.F. Guenther, and J.C. Foltz. 1992. IS942. *Pricing Nontraditional Products and Services*. Cooperative Extension, University of Idaho. 4 p. Ord. #386. *and:*
- Parker-Clark, V.J. 1992. *Marketing Your Produce Directly To Consumers*. University of Idaho, Coop. Extension System. 6 p. Ord. # 620.
- Parker-Clark, V.J. 1989. *Assessing the Potential for Farm and Ranch Recreation*. EXT699, Ord. #596. \$1.00.
- Smathers, R.L. 1992. *Understanding Budgets and the Budgeting Process*. CIS 945. University of Idaho Coop. Extension, Moscow, ID. 5 p. *Order*. 389. \$1.00.
- Maue, Patricia et al. 1995. *Growing Your Own Specialty Food Business - From Farm to Kitchen to Market*. Publication of the NYS Small Business Development Center, Ulster County Community College, Stone Ridge, NY.
- MSAWG (compiler). 1996. *Direct Marketing Resource Notebook*. Midwest Sustainable Agriculture Working Group.  
*Contains over 100 pages of practical information on direct marketing with examples of farmers, contacts for state and federal marketing regulations in the midwestern states, and other resources. Send check for \$20 (NE residents add \$1 per copy) payable to: Nebraska Sustainable Agriculture Society An update of this book is being planned for 2000.*  
P.O. Box 736  
Hartington, NE 68739  
402-254-2289.
- Mississippi's Southern Rural Development Center produced the *Food Processing Industry—Resource Directory (1997)* as a step toward addressing food processing development issues in the southern region. SRDC #205 is currently out of print, but hard copies, when available, will be \$10 from:  
SRDC  
Box 9656  
Mississippi State, MS 39762.  
601-325-3207

## Publications: (continued)

NRAES. No date. Facilities For Roadside Markets. Northeast Regional Agricultural Engineering Service (NRAES) Cornell University Ithaca, NY 14853-5701.

*The booklet, NRAES-52, is available for \$5.50. Also available from NRAES are:*

*Farming Alternatives: A Guide to Evaluating the Feasibility of New Farm-Based Enterprises (NRAES-32) for \$8 plus \$3.50 s&h and Produce Handling For Direct Marketing (NRAES-51) \$7 plus s&h. Write to:*

NRAES

152 Riley-Robb Hall

Cornell University

Ithaca, New York 14853.

607-255-7654; FAX 607-254-8770

Nebraska Extension (ed.) Setting Up Your Own Business: Financing Your Business (NebFact 96-278). Note: Only available from NE county extension offices. See [www.ianr.unl.edu/pubs](http://www.ianr.unl.edu/pubs).

Nebraska Sustainable Agriculture Society. No date. The Direct Market Resource Notebook. Hartington, NE 68739.

To order, send \$20 to:

NSAS, P.O.

Box 736,

Hartington, NE 68739.

402-254-2289.

O'Neill, Kelly. 1997. Emerging Markets for Family Farms. Center for Rural Affairs, Walthill, Nebraska. 62 p. Available for \$7 from:

CRA

PO Box 406

Walthill, NE 68067-0406.

402-846-5428.

Pacific Northwest Coop. Extension (ed.) 1980.

Farmer-to-Consumer Marketing: An Overview. Published by Washington State University Coop Extension, Oregon State University Coop

Extension, University of Idaho Coop. Extension and the USDA. Also available are:

- ✓1. *Farmer-to-Consumer Marketing: An Overview*
- ✓2. *Farmer-to-Consumer Marketing: Production and Marketing Costs*
- ✓3. *Farmer-to-Consumer Marketing: Merchandising, Pricing and Promotional Strategies*
- ✓4. *Farmer-to-Consumer Marketing: Place of Business and Product Quality*
- ✓5. *Farmer-to-Consumer Marketing: Personnel Management*

## ✓6. *Farmer-to-Consumer Marketing: Financial Management*

Order on-line at:

[http://caheinfo.wsa.edu/pub\\_home-page/pub.html](http://caheinfo.wsa.edu/pub_home-page/pub.html)

Packer, The (ed.) [Yearly]. The Packer's Produce Availability and Merchandising Guide. The Packer, Lenexa, Kansas. *Information about display and promotion, post-harvest handling of major vegetable and fruit crops. Also publishes Fresh Trends annually.*

Contact:

*The Packer 2000 Guide*

*Circulation Department*

*10901 West 84th Terrace*

*Suite 20, Lenexa, KS 66214.*

*800-255-5116.*

*Visit <http://www.thepacker.com>. The 2000 guide will be available in June.*

Richards, Keith and Wechsler, Deborah S. 1996. Making It On The Farm. Increasing Sustainability Through Value-Added Processing and Marketing. Southern Sustainable Agriculture Working Group. For copies, send check for \$12 payable to SSAWG Publications  
PO Box 324  
Elkins, AR 72727

Rocky Mountain Institute (ed.) 1987. "Marketing," How To Survive As A Small Farmer. Rocky Mountain Institute. 40 p.  
*Rocky Mountain Institute*  
*1739 Snowmass Creek Road,*  
*Snowmass, CO 81654*

Salatin, Joel. 1995. Salad Bar Beef. Polyface, Inc., Swoope, VA. 368 p.

Salatin, Joel. 1993. Pastured Poultry Profits. Polyface, Inc., Swoope, VA. 330 p.

Salt, Steve. 1999. Specialty Ethnic Produce. Order from Steve Salt, Green Valley Farm, Kirksville, MO. E-mail: [saltsgvf@istlaplata.net](mailto:saltsgvf@istlaplata.net).

Schermerhorn, R. W. 1991. Is Your Agribusiness Project Feasible? University of GA Cooperative Extension, Athens, GA. 15 p. At:  
<http://www.ces.uga.edu/pubed/b1066-2.html>.

Schmidt and Acock. Marketing Fruits and Vegetables. #570. Mississippi State Extension, Mississippi State, MS 39762.



## **Publications: (continued)**

---

Smith, Lauren K. and Cathy Roth (ed.) 1993. To Market! To Market!: Promotional Ideas That Will Bring Customers to Your Farmers' Market. AG-MARK. Cooperative Extension, University of Massachusetts, Pittsfield, MA. 20 p. To order a copy of this booklet, send \$1.50 to:

*US Extension Bookstore  
Draper Hall, B32010  
Amherst, MA 01003-2010  
413-448-8285. (no phone orders)*

Sullivan, G.H. et al. 1981. Direct Farm to Consumer Marketing: A Profitable Alternative for Family Farm Operations. #HO-160. Purdue University Extension Service, West Lafayette, IN 47907. Sustainable Agriculture Research & Education. 1999. Farming for Profit, Stewardship & Community. Tipsheet #2: Add Value Through Marketing. <http://www.sare.org/san/tipsheet/tip2.htm> 3 p.

University of California (ed.) 1999. Specialty and Minor Crops Handbook. Publication #3346. Division of Ag. and Natural Resources, Oakland, CA. *Available from the Small Farm Center for \$30 (see list of organizations for address).*

University of California (ed.) No date. Growing Across the Seasons: A Season and Harvest Extension Guide for the Small-Acreage Farmer. UC Extension. Available for \$13.73 ppd from: *UC Coop Extension  
11477 E. Avenue  
Auburn, CA 95603  
Should I Sell at the Farmer's Market available from UC Davis Coop Extension, Davis, CA 95616*

University of Delaware (ed.) No date. Guide to Planning the Farm Retail Market. University of Delaware Cooperative Extension. 85 p. Available from: *University of Delaware  
College of Agricultural Sciences  
Ag. Experimental Station Cooperative Extension  
Newark, DE 19717-1303*

University of Illinois Urbana-Champaign College of Agriculture(ed.) 1990. A Grower's Guide to Marketing Fruits, Vegetables and Herbs in Illinois. Available from: *Cooperative Extension Publications  
69 Mumford Hall  
1301 West Gregory Drive  
Urbana, IL 61801*

University of Wisconsin (ed.) No date. Direct Marketing of Farm Produce and Home Goods. Coop Extension. Available from: *Extension Publications  
630 W. Mifflin St. Room 170  
Madison, WI 53703-2636  
608-262-3346*

Wallin, Craig. 1989. Backyard Cash Crops: The Sourcebook for Growing and Selling Over 200 High-Value Specialty Crops, Homestead Design, Inc., Friday Harbor, WA. 231 p.

Whatley, Booker T. 1987. How To Make \$100,000 Farming 25 Acres. Regenerative Ag. Association, Emmaus, PA. 1987. *Focuses on location, crop selection and mix, and marketing. Gives insight on marketing strategies, equipment, high value crops. Available for \$22.50 from: American Botanist Sellers  
P.O. Box 532, Chillicothe IL 61523.  
309-274-5254; FAX: 309-274-6143.*

## **Directories:**

---

National Organic Directory (400 + p) Available for \$50.95 (CA residents add \$3.48) from: *CAFF  
PO Box 363  
Davis, CA 95617  
800-852-3832  
(lists farmers, buyers, and brokers, sustainable agriculture publications, organic certification groups, state laws etc.)*

## **Agencies/Associations:**

---

Alternative Farming Systems Information Center  
National Ag. Library  
10301 Baltimore Avenue, Room 304  
Beltsville, MD 20705-2351  
301-504-6559;  
E-mail: [afsic@nal.usda.gov](mailto:afsic@nal.usda.gov)

Farming Alternatives Program  
17 Warren Hall  
Cornell University  
Ithaca, NY 14853  
607-255-9832

Food and Agricultural Products Research and Technology Center  
Oklahoma State University  
Stillwater, OK  
*The Center's objective is to help develop successful value-added enterprises in OK. For a free fax subscription to the Food Fax Newsletter, fax a request to Peter Muriana at 405-744-6313 or call him at 405-744-5563.*

## **Agencies/Associations: (continued)**

---

Food Processing Center  
University of Nebraska  
60 Filley Hall  
Lincoln, NE 68583-0928  
402-472-5791

Contact Allis Burney

*The Entrepreneur Assistance Program helps prospective manufacturers with issues like product development, food safety, market research and selection, packaging and label design, business risk protection, product pricing, image development, regulatory issues, etc.*

Hartford Food System (Mark Winne)  
509 Wethersfield Ave.  
Hartford, CT 06114  
860-296-9325; FAX: 860-296-8326

Institute of Food Technologists  
221 N. LaSalle St., Suite 300  
Chicago, IL 60601  
800-IFT-FOOD

Missouri Alternatives Center  
628 Clark Hall  
Colombia, MO 65211  
573-882-1905 or 800-433-3704

*Provides information on alternative crops, small farm options and alternative rural opportunities.*

National Farmers Direct Marketing Association  
14850 Countryside Drive  
Aurora, OR 97002  
503-678-2455

Organic Farmer's Marketing Association  
8364 S. State Road 39  
Clayton, IN 46188  
317-539-6935; E-mail: cvof@iquest.net  
*Publishes The Organic Organizer.*

Restorative Development Initiative  
Collective Heritage Institute  
826 Camino de Monte Rey, Suite A6  
Sante Fe, New Mexico 87505  
505-986-0366; FAX 505-986-1644

*Program linking family farmers, including native American growers, directly with progressive companies and markets to facilitate the creation of an alternative agricultural economy outside the commodities market.*

Small Farm Center  
University of California  
Davis, CA 95616-8699  
916-752-8136

*Published the Specialty and Minor Crops Handbook that describes seed sources, cultivation, production and marketing alternatives for 62 crops. A bimonthly newsletter called Small Farm News is also published. Also available are Considerations in Enterprise Selection, How to Determine Your Cost of Production, Direct Marketing and Quality Control, Marketing Cooperatives, and Setting Up a Roadside Stand, three booklets that cover marketing opportunities for small farmers, and the Small Farm Handbook (169 pp, \$24.55) an easy to follow book for prospective farmers, new farmers and farmers who want to start new enterprises.*

USDA/RBS Program  
Stop 3201, 1400 Independence Avenue S.W.  
Washington, D.C. 20250-3201  
202-690-4730

*(Rural Business-Cooperative Service (RBS) helps farmers and other rural residents develop cooperatives to obtain supplies and services at lower cost and to get better prices for the products; advises rural residents on developing existing resources through cooperative action to enhance rural living; helps cooperatives improve services and operating efficiency; informs members, directors, employees, and the public on how cooperatives work and benefit their members and their communities; and encourages international cooperative programs. RBS also publishes research and educational materials, including the Farmer Cooperatives magazine).*

## **Periodicals:**

---

Acreage Advisor  
15400 N 56th St.  
Lincoln, NE 65814-9706  
402-785-2220

*Bimonthly 24-page publication geared toward the small farm and acreage owner. One year subscription is \$9.95. Contact Phil Pfeiffer.*

American Fruit Grower  
American Vegetable Grower  
Meister Publishing Co.  
37733 Euclid Avenue  
Willoughby, OH 44094  
216-942-2000

## Periodicals: (continued)

---

The Business of Herbs  
439 Ponderosa Way  
Jemez Springs, NM 87025-8036  
505-829-3448; FAX 505-829-3449  
E-mail: olives@jemez.com  
*Bimonthly, \$20 per year.*

Country Journal  
P.O. Box 500  
Mt. Morris, IL 61054

Farm Direct Marketing Digest  
P.O. Box 4612  
Pasco, WA 99302  
509-547-5538; FAX 509-547-5563

Farmers Market Monthly and Farmers Market Outlook  
PO Box 4220  
Culver City, CA 90231  
310-673-8366

*Bi-monthly newsletters on California's farmers markets. Carries farmer profiles, updates on new crops, legal and regulatory issues, interviews with chefs, authors, policy-makers and others with and interest in farmers markets. Annual subscription costs \$20.*

Farming Alternatives Newsletter  
c/o Farming Alternatives Program  
17 Warren Hall  
Cornell University  
Ithaca, NY 14853  
607-255-9832

Gourmet News  
PO Box 1056  
Yarmouth, ME 04096

The Gourmet Retailer  
3301 Ponce de Leon Boulevard, Suite 300  
Coral Gables, FL 33134  
305-446-3388

Growing for Market  
Fairplain Publications  
P.O. Box 365  
Auburn, KS 66402  
*Subscription is \$24/yr.*

Labels: Linking Consumers and Producers

*Free monthly electronic newsletter from the Institute for Agriculture and Trade Policy that provides news, events and resources related to the labeling of products for environmental, social and regional sustainability. To subscribe, send e-mail to majordomo@igc.apc.org. Leave subject blank. In body, type subscribe label-news.*

MFA Marketing Digest  
Minnesota Food Association  
2395 University Avenue, Room 309  
St. Paul, MN 55114  
612-644-2038

Contact: Anne deMeurisse  
*Reports information of interest to small-scale food producers and processors who are creating a sustainable food system in Minnesota. Features profiles of producers, processors and buyers.*

Maine Organic Farmer and Gardener  
PO Box 2176  
283 Water Street  
Farrell Building, 4th Floor  
Augusta, ME 04338  
207-622-3118

*The March-May issue 1996 is full of marketing and production ideas from the Farmer-to Farmer conference. Back issues are available for \$4.50.*

The Packer  
10901 West 84th Terrace  
Suite 20  
Lenexa, KS 66214  
800-255-5116

*Gives weekly news about marketing and production of fruits and vegetables. Produces The Packer's Produce Availability and Merchandising Guide with information on vegetable and fruit crops, display and promotion, post-harvest handling, major production areas and other useful details.*

Produce Business  
Phoenix Media Network  
P.O. Box 810425  
Boca Raton, FL 33481  
561-447-0810

*A monthly magazine available for \$48. Ask for Fran.*

Rural Enterprise  
P.O. Box 878  
Menomonee Falls, WI 53052-0878  
414-255-0100

*(discontinued but some back (1986-1992) issues still available. \$3 each.)*

## Periodicals: (continued)

---

Small Farm Digest  
USDA-CSREES  
Mail Stop 2220  
1400 Independence Avenue S. W.  
Washington, DC 20250-2220  
800-583-3071; FAX 202-401-5179  
smallfarm@reeusda.gov

*Free quarterly newsletter on farm-related trends and developments, announcements, etc. Also available from this office is the "Getting Started in Farming" series and other factsheets. See <http://www.reeusda.gov/smallfarm>.*

Small Farm Today  
3903 Ridgetrail Road  
Clark, MO 65243-9525  
800-633-2535

Specialty Crop Digest  
Homestead Design, Inc.  
P.O. Box 1058  
Bellingham, WA 98227  
360-676-5647

Stockman Grass Farmer  
P.O. Box 2300  
Ridgeland, MS 39158-2300  
800-748-9808

University of Wisconsin Coop Extension  
Direct Marketing Newsletter  
c/o John Cottingham  
Ag. Marketing Specialist  
717 Pioneer Tower  
University of Wisconsin, Platteville  
Platteville, WI 53818-3099  
608-342-1392

## Videos and Audios:

---

High-Value Marketing. 1992. Farmer-To-Farmer Series. Rodale Press, Emmaus, PA.

To order, send \$29.95 to:  
Farm Videos, c/o Rooy Media  
7407 Hilltop Drive, Frederick, MD 21702  
301-473-8797  
Contact Rooy Media for other titles in the series.

Gerber, Michael. 1995. The E Myth Seminar.  
Nightingale-Conant Corp., Niles, IL  
(Six sound cassettes on how to run a business.  
Suggests that most businesses are started by people who  
want to turn a beloved interest into an occupation.)

## Databases and listservs:

---

Foodline is a trio of databases providing international coverage of food marketing, technical and regulatory information. Foodline: International Food Market Data is a bibliographic database of global market information from approximately 250 food and beverage and related publications, Foodline: Food Science and Technology, which consists of abstracts from over 550 journals, books, reports and papers; and Foodline: Current Food Legislation, a database summarizing provisions of current food additive regulations and food composition and labeling standards for the U.S. and seven European Union countries.

The USDA's market news service gives daily or weekly updates on wholesale produce/herb/cut flower prices.

<http://www.ams.usda.gov/marketnews.htm>

The Maine Organic Farmers and Gardeners Association started a bi-weekly price report in 1996. Prices are compiled by interviewing 20 farms about what they are charging for currently available organic produce. Items for which retail and wholesale prices are listed include vegetables, berries, tree fruit, herbs, bunched flowers, seedlings, and organic meats. Report available by mail for \$10 per season from:

MOFGA,  
PO Box 2176,  
Augusta, ME 04338.

The Massachusetts Department of Ag. Has information on farmers' markets and direct marketing, mail order businesses at their website [www.massgrown.org](http://www.massgrown.org)

For 12 years of research reports, including marketing, try the SARE database at [www.sare.org/san/projects/](http://www.sare.org/san/projects/).

New Crop Resource Online Program at <http://www.hort.purdue.edu/newcrop> provides a look at new and specialty crops.

A discussion group about marketing is available on the Internet. To subscribe to direct-mkt, send the following message to [majordomo@reeusda.gov](mailto:majordomo@reeusda.gov)  
subscribe direct-mkt

For a similar discussion group for small farmers, send message to [majordomo@reeusda.gov](mailto:majordomo@reeusda.gov) Leave subject blank. In the body, type: subscribe  
smallfarm-mg

Organic Farmers Marketing Association web site has a public page and a private page where certified organic farmers can discuss markets, prices and other subjects. The private page is open only to members of the Organic Farmers Marketing Association. Send \$25 to:

OFMA  
PO Box 159  
La Farge, WI 54639

Or look up <http://www.iquest.net/ofma/>

## **Databases and listservs: (cont.)**

---

SMALLFARM-MG is a listserv that identifies small farm contacts, farmers and others interested in strengthening the capacity of small and mid-size farmers to improve their income through a systems approach. To subscribe, send mail to [majordomo@reeusda.gov](mailto:majordomo@reeusda.gov). Leave subject blank. In the body, type `subscribe smallfarm-mg Sustainable Farming Connection` is an interactive website with innovative production and marketing information. Visit <http://sunsite.unc.edu/farming-connection>  
Contact:

USDA  
AMS, F&V Division  
Market News Branch, Room 2503  
South Building,  
PO Box 96456  
Washington DC 20090-6456  
<http://www.ams.usda.gov/marketnews.htm>

A privately published report called the Organic Market News is available for \$65/year by mail and \$75 by fax. Contact

Farmer's Information Network  
PO Box 2067  
Santa Clara, CA 95055  
408-247-6778

Another is the Organic Food Business News Fax Bulletin available for \$205 and published by:

Hotline Printing and Publishing  
P.O. Box 161132  
Altamonte Springs, FL 32716  
407-628-1377

A private website promising Today's Market Prices has, as of October 1999, "reopened the registration to consult" their daily and historical prices database, free of charge. See <http://www.todaymarket.com> for culinary herbs, fruits, and vegetables.

The CA-based federal-State Market News Service gives daily reports of prices and supplies, annual summaries of shipments and prices.

California Department of Food & Agriculture  
Division of Marketing Services  
State Market News Service  
1220 N Street  
Room 126  
Sacramento, CA 95814  
(916)654-1240  
<http://www.cdfa.ca.gov>

---

**Compiled by Katherine Adam, Radhika Balasubrahmanyam, and Holly Born**

---

**November 1999**



# Feedback

1. Does this publication provide the information you were looking for?  
How could it be improved?
2. Do you know a farmer who is implementing techniques discussed in this publication? Can you provide their address and phone number?
3. Do you know of any related research that would add to the information presented here?
4. Do you know a good related website not listed in this publication?
5. Please add any other information, or comments that you wish to share.

NCAT/ATTRA  
PO Box 3657  
Fayetteville, AR 72702

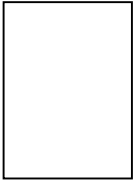

FOLD



*Thank You*  
FOR YOUR VALUABLE FEEDBACK







# Evaluating a Rural Enterprise

Marketing and Business Guide

*Abstract: Evaluating an enterprise boils down to asking a series of good questions. Among these questions are: Do I have the resources to do this? Do I really want to do this? Do I have the experience and information to do this? How much profit can I make? How will I market the products? This publication seeks to provide enough information to help you judge whether a new enterprise is right for your operation. Additionally, we provide a resource section of additional information on relevant topics.*

By **Preston Sullivan** and **Lane Greer**  
 NCAT Agriculture Specialists  
 May 2002

TABLE OF CONTENTS	
INTRODUCTION .....	1
EVALUATING YOUR RESOURCES .....	2
FINANCIAL ASSESSMENT .....	3
EXPERIENCE AND INFORMATION .....	4
MARKETING .....	5
CHOOSING AN 'ALTERNATIVE' ENTERPRISE .....	7
REFERENCES .....	8
RESOURCES .....	8

## INTRODUCTION

This publication is for people who already live in rural areas and want to add new enterprises to their operations. New farm enterprises today are often non-traditional – everything from adding pastured poultry to a beef operation to starting a bed-and-breakfast in the barn to making a cornfield maze to attract tourists.

This publication won't tell you what will make the most money. Every person and every piece

of land is different and there is no single prescription to tell you what enterprise is right for you. Any new enterprise will, however, require an investment of your time, money, and other resources. And there will always be risks involved.

There are thousands of books, Extension materials, and people who can tell you *how* to produce something, whether it's baskets, bison, or blueberries. But these resources can't help you decide whether that enterprise is right for you and your farm.

We reviewed many enterprise planning guides and have condensed their salient points in this publication. Most of these guides ask entrepreneurs to assess their personal and family objectives. They all stress the importance of having a business plan, a financial plan, and a marketing plan. The business plan will outline how the business should work and generate plans for operation. Perhaps the best thing about a detailed business plan is that it causes you to think in detail about what you are getting into. The **Resources** section at the end of this publication provides titles and ordering information for several useful guides to help determine the feasibility of your new enterprise.

Two of the very best of these publications are *Farming Alternatives: A Guide to Evaluating the Feasibility of New Farm Based Enterprises*, a work-

ATTRA is the national sustainable agriculture information service operated by the National Center for Appropriate Technology under a grant from the Rural Business-Cooperative Service, U.S. Department of Agriculture. These organizations do not recommend or endorse products, companies, or individuals. ATTRA is headquartered in Fayetteville, Arkansas (P.O. Box 3657, Fayetteville, AR 72702), with offices in Butte, Montana and Davis, California.



book from Cornell University, and *A Primer for Selecting New Enterprises for Your Farm*, a Kentucky Extension Service publication. These guides discuss alternative enterprises and introduce a step-by-step process to assess the objectives, resources, markets, production demands, and profitability of new enterprises. Both include a lot of useful worksheets to help with these assessments. See the **Resources** section for more information on how to order these publications.

## EVALUATING YOUR RESOURCES

Before committing to a new enterprise, there are always fundamental questions that ought to be addressed. These may be practical (What are the business/management skills of those involved?), organizational (Does everyone involved agree on how the business should be run?), or philosophical (Does everyone involved know, understand, and agree on the objectives, both short- and long-term?). The following are typical of the kinds of questions suggested in the sources we reviewed.

### Marketing

- Where am I going to sell the products?
- Who is the customer?
- What is the size of the potential customer base?
- Where do the customers live, and how will their location influence my selling to them?
- What are the customers' needs and desires?
- Am I going to sell directly to consumers?
- Am I going to wholesale to the commodity market?
- What are the seasonal price fluctuations I can expect?
- What are the quality standards that I must meet?
- How many hours will it take to research direct markets?
- Are there legal or food-safety considerations?

### Personal

- Do I have time to devote to this new enterprise?
- Does the workload correspond with the time of year I want to work?

Will the new enterprise complement my current enterprises?

Do I have written objectives describing the desired outcome?

Do I have the skills and experience necessary to do this?

Do I like to supervise people?

Have I managed a business before?

Do I have enough personal energy to do this?

Can I count on my family members for support?

Do I care what the neighbors think about my new enterprise?

Why do I want this enterprise?

After you have determined that the enterprise is something you really want to do, consider these additional questions (for land-based enterprises):

### Land

What is the water drainage like?

Are the soils suitable?

What is the seasonal rainfall pattern?

What will happen to my enterprises during a flood or drought?

Are these plants or animals adapted to this climatic region?

Are there water resources available for irrigation or for watering livestock?

Do I want concurrent uses for the land such as wildlife conservation, fishing, or hunting?

### Buildings and Machinery

Do I have adequate facilities?

What additional machinery will I need?

Can I rent or borrow machinery or storage facilities?

### Labor Needs

How much labor will be required?

What is the source of labor?

How much will it cost?

Is seasonal labor available?

Will I need housing for my workers?

Does this enterprise use existing labor in off-seasons?

There are many resources that can guide you in your search for the answers to these questions. See the **Resources** section at the end of this publication for more information.

## FINANCIAL ASSESSMENT

After you have answered the above questions, you'll have a better idea of what costs will be involved in a new enterprise, and that information will help you determine the profit potential. It is advisable to do the following exercise before spending more time or money developing the logistics of production or a full enterprise budget.

One way to compare enterprises for profitability is to calculate a **gross profit analysis** (Savory and Butterfield, 1999), otherwise known as gross margin analysis (Kay and Edwards, 1994) or a contributory margin (Zimmerman and Villanueva, 2001). The gross profit or margin is the amount of money left over after all the *new* costs associated with the new enterprise are subtracted from the gross income generated by that new enterprise. These *new* expenses are separate from the general overhead expense, because they are incurred *only* if the new enterprise is implemented. In other words, these are the variable costs associated with a new enterprise.

To avoid confusing comparisons, do not prorate the overhead (fixed costs) for enterprises in this exercise. You will get more accurate results by assuming that the entire overhead cost must be paid out of the gross profit from the enterprise. For example, if you need to use your tractor in a new venture, the cost of owning the tractor (payments, insurance, etc.) is already fixed. But the direct expense of using the tractor in your new enterprise (fuel, routine maintenance) can be assigned to the operating cost of the venture that uses the tractor. By subtracting these operating costs from the total sales, you arrive at the gross profit. The gross profit from all enterprises combined must be at least enough to cover the overhead or you will go broke.

Table 1 shows the gross margin for a sweet corn enterprise. Figures are generated on a per-acre basis and so can be compared to any other enter-

prise on a per-acre basis. Notice how *only* the costs directly related to that enterprise are included in the gross profit analysis. Land rent could also be included, but if the land is already owned or mortgaged, it should be left out of this analysis and considered a fixed cost. With this sweet corn enterprise we have \$2,444 gross profit left to pay overhead costs and, ideally, provide a profit, if a profit was initially projected.

**Table 1. Gross profit for one acre of sweet corn.**

Total Income	Dollars
1,200 dozen @ \$2.50	\$3,000.00
<b>Variable Costs</b>	
Seed	\$ 50.00
Fertilizer	\$ 35.00
Weed Control	\$ 18.00
Machinery Use	\$ 83.00
Harvesting	\$ 345.00
Hauling	\$ 25.00
<b>Total Variable Costs</b>	\$ 656.00
<b>Gross Profit/acre</b>	\$2,444.00

To make valid comparisons between enterprises using gross profit or margin analysis, use a common unit of measure. A common unit for agriculture is gross profit per acre. For some other enterprises, units to consider might be profit per hour or \$/bushel or \$/cwt. Using a common unit will allow you to compare dissimilar enterprises—such as broccoli for fresh market sales and goats sold wholesale. A per-acre comparison shows the best return on the land. Another good use of the gross profit analysis is to compare all your existing enterprises for their contribution to covering overhead costs. The results may surprise you. For example, you may find that the principal enterprise is actually being supported by several secondary enterprises.

In cases where there is no overlap between two enterprises, a direct comparison may not be pos-

sible. An example of this would be if you already had grazing and timber enterprises and wanted to add a lease-arrangement hunting lodge to the same land. The only variable costs associated with the enterprise might be legal fees, renovation costs on the house, and maintenance. In this case, if the gross profit was still high, and you responded positively to the personal questions above, you would go ahead with the enterprise.

The gross profit analysis does *not* preclude full financial planning for each enterprise and for the whole farm. If, for example, the overhead costs are in excess of all the income generated, you will go broke. If you are buying new equipment (fixed cost) specifically for an enterprise, that cost can be assigned to that enterprise and amortized over the useful life of the machinery. If you borrow money to buy the equipment, the loan payment can be allocated as a variable expense for the enterprise gross profit analysis. In the whole-farm budget, all the income from all the various enterprises will be included, along with the variable costs for each and the overhead expenses.

Full planning budgets used to estimate costs for many farm enterprises should be available from your local Extension service. Others can be found at: <http://www.fbminet.ca/bc/budget.htm>, a web site with enterprise budgets for a large number of crop and livestock enterprises. The budgets at this web site use the term “contribution margin” to describe gross profit. These budgets are separated into contribution margin and buildings and machinery replacement costs (overhead). The budgets are laid out in an easy-to-read format with an overview preceding the tables. Each enterprise budget contains marketing alternatives, cash flow timing, and key factors affecting profit, with margin estimates already calculated. When calculating your cost of production, be sure to use reliable estimates for your situation and include other costs that may not be listed in the budget. It is also useful to project poor, average, and good production scenarios for each enterprise. If you cannot be profitable with poor production, consider another enterprise.

## EXPERIENCE AND INFORMATION

“The most salient requirement for farming is experience” (Nation, 1998). Practical experience is particularly important for a new enterprise, especially if the enterprise is not related to what you normally do. You can gain a lot of the necessary knowledge from people who are currently doing what you are considering. Apprenticing with someone who is already farming, or just volunteering some time, is a good way to get experience. (See ATTRA’s resource list [Sustainable Farming Internships and Apprenticeships](#) for more information on experiential farm work across the country.) Also, start out small with your own enterprise until you learn the basics. *Stockman Grass Farmer* editor Allan Nation (1997) suggests these four stages when considering a new enterprise:

1. *Get the knowledge you need to produce and market the product.*
2. *Produce it for yourself and your family.*
3. *Produce it for your friends who have tried it, like it, and ask you for it.*
4. *Do it as a business.*

Although this approach may seem slow, it will go faster and require a lot less startup investment than jumping in and trying to learn as you go.

Gathering information on specific enterprises is also an important step when considering diversification. Your local Cooperative Extension Service and other USDA agencies can provide fundamental information about some alternatives, as can non-profit organizations in your state. You can also contact Extension specialists at your state’s land-grant university. Other sources of information include websites and publications (books, magazines, and newsletters). The resource list at the end of this publication also provides helpful information.

Often, however, even though there is production information for a specific crop, there is little information available on budgets or markets. Your best resource in a situation like this will prob-

ably be a farmer who is already raising, or someone who is already buying, the crop or a similar crop. A good way to find farmers is to attend state or regional workshops or conferences that are in some way related to your area of interest. Extension puts on workshops throughout the year that provide an opportunity to network with your fellow growers. The approach to finding buyers would be similar. For instance, if you are interested in adding cut flowers to your farm's mix, you might attend a statewide conference for florists.

## MARKETING

Author and business consultant Peter Drucker says that only two activities produce results. One is innovation, and the other is marketing (Nation, 1997). Marketing may take many forms, ranging from passive marketing into the commodity chain all the way up to marketing a retail product directly to consumers. Which marketing method you choose will have a profound effect on the price your product commands. Prices in many prepared budgets will typically be wholesale prices. Adjust these prices to your local market (retail or wholesale) based on what you can realistically expect to get paid. Visit with other farmers in your area who are selling the same thing you want to sell, or go to the local farmers' market and check out prices.

There are two important reasons for doing market research:

- You need to understand your market, your competition, and consumer trends
- You need to be able to project potential sales volume and prices (Grudens-Schuck and Green, 1991)

The Cornell *Farming Alternatives* guide mentioned earlier has marketing worksheets that address the following considerations:

- *Target Market Descriptions*  
The demographics of people you want to sell to (age, gender, family status, income level, class, occupation, children, marital status, location, ethnic group, education).

- *Marketing Options*  
These include any method used to sell or distribute your product (Grudens-Schuck and Green, 1991). Examples are selling directly to consumers from the farm; farmers' markets; selling directly to restaurants; cooperative marketing; selling wholesale to a distributor, broker, or processor; etc. Identify your most promising options. Also consider transportation needs and distances to market.
- *Market Entry*  
How will you introduce the product to the market? Will it be marketed under the producer's or processor's name? What will get the buyer's attention (advertising and promotion)? (Schermehorn).
- *Existing Market Demand*  
How many potential buyers are included in your target market at this time? What is the average purchase or frequency of service per buyer per year? What are the total purchases or number of services per year?
- *Competition*  
Analyze your competition: business name, estimated sales volume, quality of product, price, customer satisfaction, appearance, type of buyer targeted, strengths, weaknesses. "Direct competition" offers the same product you do; "indirect competition" is anything your target market can substitute for your product. Remember: alliances can be formed with competitors.
- *Market Trends*  
Has consumption been increasing? Is the number of competitors increasing? What are your projections for market trends in the next five to ten years? What are the industry trends and emerging markets?
- *Expected Price*  
There are many formulas and strategies for setting prices. What is the lowest price you can expect to receive? What is the

highest price? Ultimately, pricing will reflect your competition, costs of production, quality, service, the convenience you provide, and the types of buyers you have targeted.

- *Expected Sales Volume*

What is the least number of units you might sell in a bad year? How many in a good year? What is the expected sales volume? How long will it take to build the market to your desired sales volume?

Direct marketing involves personally connecting with consumers, determining what they want or need, and producing the products that meet their needs. Author Joel Salatin, who raises pastured beef and poultry in Virginia, suggests several things to think about when deciding on pricing your products. First, don't under-price them. Farm-produced products are superior because they are more environmentally friendly and humanely produced. Salatin suggests that producers set a rewarding and satisfying gross margin and then stick to it. This will allow you to build a customer base with clients who appreciate the product for what it is, not for what it costs (Salatin, 1998). Your estimated price can be used to calculate returns in any enterprise analysis.

Direct marketing depends on building relationships with customers. In fact, the term *relationship marketing* has been used to describe the best methods of direct marketing for family farms. In an article in *The Stockman Grass Farmer* (Nation, 1997) Joel Salatin sets out five advantages of relationship marketing. They are:

**Consumer Education.** The producer has to tell the consumers why his farm products are different from those bought in the grocery stores. This is not only good for business, it is also a small step toward the development of the consumer's awareness about farm, social, and health issues that affect our lives.

**Product Quality.** When the producer raises crops or livestock in an environmentally friendly or sustainable fashion, it is easier not to compromise the quality of the products.

**Customer Loyalty.** When the consumer knows the producer personally, the relationship between them is not easily broken. Good sellers know and use their customers' names. Loyalty helps bring in repeat customers.

**Lifestyle.** As Salatin explains, "I think one of the biggest differences between the pressures I encounter as a small operator and the pressures encountered by the big operators is the amount of control we have over the situations that cause pressure" (Nation, 1997).

**Balance.** The first rule of business is that the customer is always right, but that doesn't always mean you have the right customer. In some instances, removing a name from your customer list may help to balance the producer-consumer relationship, so that you can concentrate on profitable sales, appreciative customers, people who "get with the program" (Nation, 1997).

Allan Nation says, "If you are considering getting into direct marketing, don't bet the farm on it. Keep doing what you are doing for a living and start learning and experimenting on a small scale. Try the food you produce on your family and your friends first. If your family and friends are not crazy about it there is more learning to be done. Nation adds that, "A new business needs virtually 100% customer satisfaction from day one to survive" (Salatin, 1998).

So the bottom line is to establish markets *before* you begin the enterprise. If you are direct marketing, consider these questions before starting production: What do the people in my area want? What are their tastes? Are they accustomed to "store bought" eggs, meat, and vegetables? What matters most to people in my local area—convenience and price? Are they willing to *pay* for the quality and freshness of locally grown food?

For more complete information on direct marketing, call and request the three ATTRA publications entitled *Direct Marketing, Farmers' Markets*, and CSAs. The direct marketing publication includes information about resources,

market development, market research, marketing plans, niche marketing, product differentiation, farmers' markets, value-added marketing, and examples of real farmers who have done it. It also provides a list of recommended resources to consult when considering your market plan.

## CHOOSING AN 'ALTERNATIVE' ENTERPRISE

There are many kinds of enterprises that can be profitable in a rural area. Ken Scharabok's book (see **Resources**) describes 300 specific rural enterprises. Cornell University's publication *Farming Alternatives* lists several broad categories:

1. *Nontraditional crops, livestock, and other farm products*
2. *Service, recreation, tourism, food processing, forest/woodlot, and other enterprises based on farm and natural resources*
3. *Unconventional production systems such as organic farming and aquaculture*
4. *Direct marketing and other entrepreneurial marketing strategies*

When considering alternative enterprises, you should look first at your farm's underutilized resources and your area's market opportunities. Underutilized resources might include unused buildings, or manure that could be sold as fertilizer. New market opportunities may arise as a result of changing demographics in your area—there may be an increase in immigrant families who want specialty foods, or of affluent businesspeople who commute to a metropolitan area ([Grudens-Schuck and Green, 1991](#)).

One very important change in national demographics is the number of people who have become dissociated from the land. Few of the baby boomer generation and almost none of Generation X have lived on and worked the land. In an effort to re-establish that bond, young consumers are often eager to support small farms, and they're willing to put their money where their mouth is. The huge increase in the number of farmers' markets around the country not only means that consumers are interested in fresh pro-

duce, it also reflects their desire to have a different kind of food shopping experience. For similar reasons, community supported agriculture arrangements (CSAs) have become popular. Both farmers' markets and CSAs bring shoppers closer to farmers and to the land, an experience that is largely lacking in today's urban society. An extension of these encounters is a farm visit, whether it's for a hay ride, to go to a petting zoo, or to attend an apple festival. Consumers like to feel that they are helping to keep small, family farms alive. This kind of experience requires farmers to learn new skills: how to deal with the public, the ability to assess unique opportunities on the farm, and the vision to produce a feeling as well as a product.

In his 1998 book *You Can Farm*, Joel Salatin recommends ten enterprises that he considers excellent: pastured poultry, eggs, salad bar beef, a grass-based dairy, a market garden, a home bakery, a bandsaw mill, and a you-pick small fruit orchard. His criteria for recommending these enterprises are:

- Low initial start-up cost relative to the ability to generate income
- High gross profit margin
- Relatively low maintenance requirements
- High cash flow relative to expenses
- History of high success rates among new enterprises
- High demand, low supply in the current marketplace
- High product distinctiveness
- Relatively size-neutral profit potential

"The goal here is to examine what the profitable alternatives are in the current paradigm and how you can fit in the picture" ([Salatin, 1998](#)).

There are lots of places to find out more about specific enterprises. The Missouri Alternatives Center's website provides many links to specific production information for various alternative enterprises. This website is extensive and up-to-date <<http://agebb.missouri.edu/mac>>. Additionally, we have listed many valuable resources below.

## REFERENCES

Grudens-Schuck, Nancy and Judy Green. 1991. *Farming Alternatives: A Guide to Evaluating the Feasibility of New Farm-Based Enterprises*. Northeast Regional Agricultural Engineering Service, Cornell University, Ithaca, NY. 88 p.

Kay, R.E. and W.M. Edwards. 1994. *Farm management*, 3<sup>rd</sup> edition. McGraw Hill, Inc., New York, NY. 458 p.

Nation, Allan. 1998. Allan's Observations. *Stockman Grass Farmer*. Vol. 56, No. 6. p. 13.

Nation, Allan. 1997. *Paddock Shift*. Green Park Press, division of Valley Publishing Corp., Jackson, MS. 184 p.

Salatin, Joel. 1998. *You Can Farm*. Polyface, Inc., Swoope, VA. 480 p.

Savory, Allan and Jody Butterfield. 1999. *Holistic Management: A New Framework for Decision Making*. Island Press, Washington, DC. 550 p.

Schermerhorn, Richard W. No date. *Is Your Agribusiness Project Feasible?* University of Georgia Cooperative Extension. <<http://www.ces.uga.edu/pubcd/b1066-w.html>>.

Zimmerman, K. and E. Villanueva. 2001. *Fresh sweet corn direct marketed (Fraser Valley)*. Planning for Profit. British Columbia Ministry of Agriculture, Food and Fisheries. 8 p.

## RESOURCES

### Publications and Videos

Salatin, Joel. 1998. **You Can Farm: The Entrepreneur's Guide to Start and Succeed in a Farm Enterprise**. Polyface, Swoope, VA. 480 p.

*Perhaps the best single resource for beginning farmers, this book also provides good information on enterprise differentiation and evaluation. Available for \$30 from the author at:*

Polyface Inc.  
Rt. 1, Box 281  
Swoope, VA 24479  
540-885-3590

*The book is also available for \$24.50 from:*  
<http://www.amazon.com>

Grudens-Shuck, N. and J. Green. 1991. **Farming Alternatives: A Guide to Evaluating the Feasibility of New Farm Based Enterprises**. Farming Alternatives Program, Cornell University, Ithaca, NY. 88 p.

*This publication uses a step-by-step process to assess goals, resources, markets, etc. Includes worksheets. Available for \$8 from:*

Media Services Resource Center  
7 Business & Technology Park  
Cornell University  
Ithaca, NY 14850  
607-255-2080  
FAX: 607-255-9946  
<http://www.cornell.edu/publications.catalog.html>

**Farming Alternatives: Innovation on Northeast Farms**. A 14-minute video produced in 1988.

*Explores the issues involved in the development of farm-based enterprises such as deer farms, farm markets, bed and breakfast inns, herb gardens, petting zoos, and farm-processed foods. Available for \$18.95 from the Cornell address above.*

Woods, Tom and Steve Isaacs. 2000. **A Primer for Selecting New Enterprises for Your Farm**. Cooperative Extension Service. University of Kentucky. *Agricultural Economics - Extension* No. 00-13. 28 p.

*Covers profitability, resources, information, marketing, enthusiasm, and risk. Has many useful worksheets from which accurate information can be generated to guide your decision making. Available online at:*  
<http://www.uky.edu/Ag/AgEcon/publications/ext2000-13.pdf>

Scharabok, Ken. 1996. **How to Earn Extra Money in the Country**. A Country Living Resources Guide.



*Contains over 300 descriptions of enterprises that can be pursued by rural residents. Each description contains information on what the market would be, how to start the business, and additional resources on that particular business. Contains many innovative business ideas. Available in electronic form only by e-mailing <[scharabo@aol.com](mailto:scharabo@aol.com)>.*

Humphrey, Shirley (ed.). 1994. **Small Farm Handbook**. Publication SFP001. Small Farm Program, University of California. 170 p.

*Somewhat regionally specific to California, but contains good information on finances, marketing, enterprise ideas, growing crops, raising animals, postharvest handling, alternative agriculture, labor management, and keeping the family farm healthy. Available for \$20 from:*

Division of Agriculture and  
Natural Resources (DANR)  
University of California  
6701 San Pablo Ave.  
Oakland, CA 94608-1239  
800-994-8849  
510-642-2431

Small Farm Center. 1998. **Specialty and Minor Crops Handbook, 2<sup>nd</sup> ed.** University of California. Division of Agriculture and Natural Resources, Oakland, CA. 184 p.

*Compiled and edited by scientists, University of California Cooperative Extension advisors, and growers, this handbook profiles 63 specialty and minor crops, including information on production and marketing. Available for \$35 from DANR at the University of California (see address above).*

Thompson, Nancy C. 1994. **Sustainable Agriculture Enterprises: Opportunities for Employment and Economic Development in a Sustainable Agriculture System**. 21 p.

*Available for \$8 ppd from:*

Center for Rural Affairs  
P.O. Box 406  
Walthill, NE 68067  
402-846-5428  
<http://www.cfra.org>

Olson, Michael. 1991. **Metro Farm: The Guide to Growing for Big Profit on a Small Parcel of Land**. TS Books, Santa Cruz, CA. 520 p.

*Contains information on marketing, selecting crops, organizing a business, selling, and production. Available for \$29.95 plus \$5 S&H from:*

Schatz Publishing Group  
11950 W. Highland Ave.  
Blackwell, OK 74631  
888-474-6397 (toll-free)  
<http://www.agventures.com/>

Savory, Allan and Jody Butterfield. 1998. **Holistic Management: A New Framework for Decision Making**. Island Press, Washington, DC. 550 p.

*Provides valuable information for goal setting, financial planning and farming in tune with nature's principles. Available for \$30 (softcover) or \$50 (hardcover) from:*

The Allan Savory Center for Holistic  
Management  
1010 Tijeras NW  
Albuquerque, NM 87102  
505-842-5252  
505-843-7900 fax  
<http://www.holisticmanagement.org>

#### Periodicals

**AgVentures: The Magazine of Agricultural Opportunities** is published bi-monthly. It features new and unusual crops and livestock to raise. It is available for \$21/year from:

AgVentures  
11950 W. Highland Ave.  
Blackwell, OK 74631  
580-628-4551  
580-628-2011 fax  
<http://www.agventures.com>  
e-mail: [agventures@aol.com](mailto:agventures@aol.com)

**Ag Opportunities** is a newsletter published by the Missouri Alternatives Center (MAC) that is devoted to the latest ideas and opportunities for those "who want to begin farming, diversify their current operations, or find ways to profit from

small amounts of acreage." Subscriptions cost \$10 a year (free to Missouri residents). An on-line version is available free at MAC's website < <http://agebb.missouri.edu/mac>>. Contact MAC at:

Missouri Alternatives Center  
531 Clark Hall  
Columbia, MO 65211  
573-882-1905  
800-433-3704 (MO only)  
<http://agebb.missouri.edu/mac>  
e-mail: [kellid@umsystem.edu](mailto:kellid@umsystem.edu)

**Small Farm Today**, published bi-monthly, focuses on small farming, rural living, sustainability, community, and "agripneurship." The editor and staff hold an annual conference in Columbia, Missouri (around the first week of November) that concentrates on topics of concern to small farmers considering diversification strategies. The periodical is available for \$23.95/year from:

Small Farm Today  
3903 W. Ridge Trail Rd.  
Clark, MO 65243-9525  
800-633-2535  
573-687-3525  
e-mail: [smallfarm@socket.net](mailto:smallfarm@socket.net)

#### Organizations

##### **Center for Rural Affairs**

P.O. Box 406  
Walthill, NE 68067  
402-846-5428  
<http://www.cfra.org>

*The Center for Rural Affairs, a non-profit organization, publishes The Beginning Farmer, a free quarterly newsletter. They also published a 118-page book entitled Resourceful Farming: A Primer for Family Farmers, written in 1987, available for \$7.*

##### **Community, Food, and Agricultural Program (CFAP)**

216 Warren Hall  
Cornell University  
Ithaca, NY 14853  
607-255-9832  
<http://www.CFAP.org>

*The mission of CFAP is to support Agriculture and Food Systems-based Community Development in New York and the Northeast through integrated and multi-disciplinary teaching, research, and extension programs.*

##### **NxLevel's Alternative Agriculture series: Tilling the Soil of Opportunity**

A Training Course  
(No physical address)  
e-mail: [Info@nxlevel.org](mailto:Info@nxlevel.org)  
800-873-9378

*The NxLevel agriculture program is designed to help a broad range of small to mid-sized farmers, ranchers, food processors, distributors, retailers, food professionals, and others working in the agricultural sector take their business to the "next level." Educators in each region adapt the course to meet local needs. The materials used in the 10-session course are specifically designed for those searching for innovative ideas and better marketing opportunities in the area of agriculture.*

#### Web Sites

**Fact Sheets on Operating a Profitable Small Farm.** University of Maryland.  
<http://www.agnr.umd.edu/users/frederick/pubs>

**Planning for Profit.** British Columbia Ministry of Agriculture, Fisheries and Food.  
*Numerous two page enterprise budgets.*  
<http://www.fbminet.ca/bc/budget.htm>

**Alternative Enterprises for Your Forest Land: Forest Grazing, Christmas Trees, Hunting Leases, Pine Straw, Fee Fishing and Firewood.** This is a 1988 publication from the University of Florida Extension Service.  
<http://www.sfrc.ufl.edu/Extension/pubtxt/cir810.htm>

**Missouri Alternatives Center.** Links to specific production information for numerous alternative enterprises.  
<http://agebb.missouri.edu/mac>

**Enterprise Budget Analysis.** Penn State's Agriculture Alternatives website.

*Sample formats are given.*

<http://pubs.cas.psu.edu/FreePubs/ua258.html>

**Economic Analysis of a New Business – Doing it Right.** Kansas State University Cooperative Extension Service.

<http://www.oznet.ksu.edu/library/agec2/MF2184.PDF>

By **Preston Sullivan** and Lane Greer  
NCAT Agriculture Specialists

Edited by Paul Williams and Richard Earles  
Formatted by Cynthia Arnold

062305

The electronic version of **Evaluating a Rural Enterprise** is located at:

HTML

<http://www.attra.ncat.org/attra-pub/evalrural.html>

PDF

<http://www.attra.ncat.org/attra-pub/PDF/evalrural.pdf>



# KEYS TO SUCCESS

## *in Value-Added Agriculture*

By Holly Born



**Abstract:** Fourteen farmers in the Southern U.S. were interviewed for a project funded, in part, by the USDA's Southern Region Sustainable Agriculture Research & Education (SARE) Program. This publication presents, largely in the farmers' own words, important lessons they learned in adding value to their farm products and marketing directly to consumers. The keys to their success in value-added agriculture include high quality, good record-keeping, planning and evaluation, perseverance, focus, and building long-term relationships with customers.

### Contents

<b>Introduction</b>	
<i>Updating the Keys to Success</i> .....	1
<i>Sustainable Profits</i> .....	1
<i>Translating Uniqueness into a Sustainable Advantage</i> .....	1
<b>Keys to Success</b>	
<i>In the Short Run</i> .....	3
<i>In the Long Run</i> .....	13
<b>Resources</b> .....	16
<b>About the Farmers</b> .....	18



A publication of  
 Southern Sustainable Agriculture Working Group  
 and  
 The National Center for Appropriate Technology's  
 ATTRA Project  
 January 2001



## Introduction

### *Updating the Keys to Success*

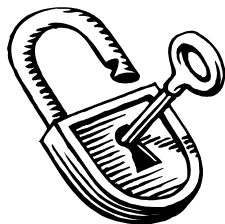

In 1995, Southern SAWG conducted on-farm interviews with twenty-four farmers from around the South who were adding value to their raw farm products and marketing more directly to consumers. From those interviews, we produced the booklet, *Making It On the Farm: Increasing Sustainability Through Value-added Processing and Marketing*, which listed ten general business practices that we considered keys to success.

Having completed a round of more intensive phone interviews with another fourteen farmers for a project funded in part by the Southern Region SARE program, it's time to update our keys to success, in the context of sustainable profitability. We believe that profitability is essential to truly sustainable agriculture. As we stressed in the first booklet, there is no simple blueprint for success when you're trying to add value to your farm products. It takes hard work, ingenuity, and a financial investment no matter what you do. However, a few general practices emerged from our interviews that could be considered keys to success. Many of these keys are fundamental for the success of any small business, while some are unique to farm-based, value-added enterprises. All should be shaped to your particular situation rather than taken as absolute rules.

### *Sustainable Profits*



Profits can be earned in many ways. Most business owners tend to concentrate on increasing sales in order to increase profits. However, cutting costs can be an easier way to increase profits. If your current profit margin is 5%, then you can double your profits by either doubling your sales (a 100% increase) or by cutting your costs by 5%. Which option do you think is easier? Here's an example:

However, you can only cut costs so far before the quality of your product and the services you provide begin to deteriorate. Thus, this is not a sustainable strategy in and of itself. This is where adding value comes in. In the Current Case example above, if you can charge 5% more without hurting sales, then your profit is also \$50. (If you can cut costs *and* raise prices by 5%, your profit goes up another 50% to \$75!)

### *Translating Uniqueness into a Sustainable Advantage*



Dr. John Ikerd, formerly at the University of Missouri and long a champion of sustainable agriculture, had this to say about sustainable profits (1):

If you decide to produce exactly the same thing that someone else is producing in the same way they are producing it, and if you succeed, any profits you realize will not be sustainable and neither will theirs. If you expect someone else to provide you with opportunities, you are destined to be disappointed. If you expect someone else to solve your problems, you will be disappointed. You have to do something creative and productive yourself if you expect the market to reward you for having done it. And, if it's easy to do, it won't be worth much.

If someone else provides you with a market, they – not you, ultimately will realize the benefit. You didn't create the market – they did. If someone else provides you with a new pest management or fertility program, they – not you, ultimately will realize the benefit. You didn't increase productivity – they did. You certainly can learn from others and can integrate others' marketing and production services into 'your' production/marketing system.... *[But] your uniqueness is the only source of profitability that cannot be competed away, and thus, is the only source of sustainable profits.*

Current Case	Double Sales	Cut Costs by 5%
Sales: 100 units @ \$5 = \$500	Sales: 200 units @ \$5 = \$1000	Sales: 100 units @ \$5 = \$500
Costs: 100 units @ \$4.75 = \$475	Costs: 200 units @ \$4.75 = \$950	Costs: 100 units @ \$4.5 = \$450
Profit = \$25	Profit = \$50	Profit = \$50

What is a competitive advantage? Basically, it's business jargon for anything that keeps others from successfully competing with you. It may come from being able to sell at the lowest price due to scale economies, having a monopoly, or being among the first to produce or market in a new way. Most farmers are not in the position to find advantage in the first two ways. Most farmers *can* change their production and marketing systems, and increasing numbers of farmers are producing new crops and new products, and experimenting with alternative marketing methods.

A competitive advantage is almost always short-lived. The nature of the market is such that only the innovators, the first ones to take the risks, are going to profit. As others learn how to produce that new crop or enter that new market, competition will drive prices down and profits will disappear.

"Identify a niche and the type of market to fill that niche," advises an interviewee. Niche marketing—selecting a specific group of consumers and targeting them in your marketing effort—is a system that farmers are hearing about more and more. For many farmers, the niche approach has paid off. But, just as we see organics going from niche to mainstream, any profits from a niche will gradually be competed away as others notice it. Unless you are fortunate enough—very unlikely!—to be the only one who can fill that niche, your profits will decline. The process of finding and filling niches is ongoing, not a one-time event.

Success in the short run requires producing a high-quality product or service, working to increase sales and cut costs, diversifying to reduce risk, and finding niche markets where the added value of your product can be realized in higher prices.

Success in the long run requires all of the above, plus the added advantage that comes from whatever it is about your operation that cannot be copied, or can only be copied with great difficulty or expense. For example, focusing on your location will attract buyers who want to "buy local." Tell the story of your farm—no one else will have quite the same story.



## ***Adding Value to Milk***

A cheesemaker says, "The hardest part of planning was finding the time to do it! It was difficult to find other representative businesses to serve as a model or template. In deciding how to market, I first had to consider what would generate the quickest cash flow. The specialty cheese niche depends on retailers whose customers would be likely to appreciate the product. I identified a niche, but I could have used a whole lot more education. Certain markets set me back because of the difficulty of entrance.

Putting her ideas into practice proved challenging. "I had to consider how to distribute my products and whom to actually approach," she says. "My local farmers' market is open to producers only, so I have to attend the market myself, which takes a huge amount of time.

"I began making catalog sales three years ago. Shipping is a problem, though. It's really expensive on a perishable product, since you have to ship by two-day air. Information is lacking on better routes or methods. I considered a website with online ordering, but it takes enormous amounts of management knowledge, and you still have the problem of shipping.

"I find that person-to-person sales are the most effective marketing strategy. Wholesaling is the least effective, as buyers are slow to pay. It's really hard to enter retail outlets, such as specialty shops, and months of promotion are usually required. I need to redesign my brochure to address deli and restaurant needs. I've broadened my marketing methods since I began, but I always had a mental plan of markets to develop."

## ***KEYS TO SUCCESS IN THE SHORT RUN***

- ◆ Start small and grow naturally
- ◆ Make decisions based on
- ◆ good records
- ◆ Create a high-quality product
- ◆ Follow demand-driven production
- ◆ Get the whole family or partners
- ◆ involved
- ◆ Keep informed
- ◆ Plan for the future
- ◆ Continuous evaluation
- ◆ Perseverance
- ◆ Adequate capitalization



### *Start small and grow naturally*

“Grow slowly at an organic rate. Watch what sells. Don’t increase debt load. Farmers’ markets are a safe training ground to begin selling.”

– a flower grower

“Start small and don’t grow too fast,” advises a salad mix grower, echoing the opinions of most of our interviewees. “Don’t start too big and invest a lot of money. Be patient and go through your research and development phase. Whatever you start with, try to get ALL the profit – no wholesalers!” You’ll be learning, and naturally making mistakes along the way. Starting small means that your mistakes are likely to be less costly. If you’re new to managing an agricultural enterprise, it is much easier to manage a small operation.

A producer of baked goods and preserves says, “We began value-adding to diversify. Ninety percent of our product ingredients are grown on-farm. We also needed to make



more money. We started a step at a time. First, we looked around to see what the market wasn’t providing and then we attempted to fill that need, adding and dropping products as we went along. We’re not into large, large volume. We only do 100 to 150 cases per year.”

The flower grower’s recommendation to start with farmers’ markets is an excellent one, for many reasons. While selling at farmers’ markets is time-consuming, costs are low. In addition, many producers find that farmers’ markets are a great place to begin building relationships with customers.

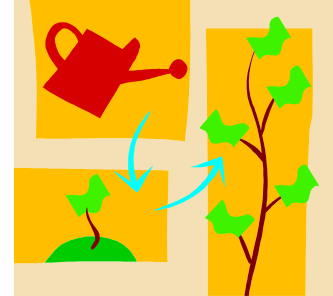

Many successful marketers began with a client base established through interactions at the farmers’ market. A cheesemaker started with farmers’ market and other direct sales in order to get contact with customers and to learn the business, relying on some thirty years’ experience in direct sales in a different line of business. She started by selling at the wholesale price. “I looked at cheese prices in specialty and retail stores, and I raised my farmers’ market prices to retail level.”

Our interviewees discussed their most important problems in starting the enterprise. Marketing and lack of familiarity with the product by customers were mentioned by four respondents, followed by financing, lack of technical information and available expertise, and lack of labor (three respondents each). Two respondents mentioned zoning, tax, sanitary, and other legalities.

Only two producers said that complying with regulations presented a hindrance to their business; as one producer said, “regulations were the least of my problems!” Of the two who did have difficulty, the expense and time involved in complying with regulations was mentioned. One producer had problems at first because



the authorities in her area were unfamiliar with the products she produces, so she had to help educate them.

When asked whether taxes had caused any problems in running the business, four of the fourteen said yes. The time involved was cited as the most important problem. One respondent said taxes were “a hidden cost that is complicated and time consuming, especially if you’re expanding.” Workers’ compensation for employees and liability for property tax for grain in storage were also mentioned.

Finally, one grower emphasizes, “Don’t go into it thinking that you’ll make a bundle!”



### *Make decisions based on good records*

“Our biggest challenge was adapting to a new environment. Keeping careful records and maps to determine what to plant, based on what grows well here and what sells, has been crucial.”  
— a flower grower

Trying to manage and grow an enterprise without good records is like trying to find an address in a strange city without a map. Without records, you are limited to making educated guesses about the progress of your business, whether or not you are meeting your goals, and the possible reasons why or why not. Only two of the producers said that they were not keeping records, but even these two turned out to be keeping at least some records for tax purposes.

Fifty-seven percent of the producers relied on a computerized system, with QuickBooks software mentioned by three respondents as their system of choice. “QuickBooks is a really great computer bookkeeping system,” says one. Quicken was mentioned by one respondent and the other four did not specify what software they used. Two respondents relied on old-fashioned ledgers, and the others relied on sales and production records and notes and minutes of their corporate meetings.

Half of the producers had previous experience in financial management in non-agricultural businesses. The others were nearly all self-taught. Of those, two mentioned getting assistance from their accountants. Two producers mentioned that they were still learning, and wanted and needed to learn more about financial management.



### *Create a high-quality product*

“Number one is having a good product.”  
— a specialty condiments producer



Since these farmers can’t compete in the high-volume commodity markets, they have to concentrate on quality, not quantity. “Offer a very, very, very high-quality product,” says a grower. “Quality” is made up of many dimensions. Fresh, better tasting, clean, reliable, sustainably produced...it may be hard to define, but these producers know it when they grow and process it. And consumers know it when they taste it!

While it may be tempting to use seconds, culls, or damaged fruits, vegetables, and herbs in processed food products, the wise grower will resist that temptation if he or she is serious about developing the enterprise. As one grower says, “For goodness’ sake, do it right! No low-grade, substandard ingredients, since the buyer knows what he’s getting. No blending! This is a downfall for a lot of specialty farmers, who don’t want to throw away half the crop if it is substandard.”

With growing concern today about food safety, it is important that products be safe to eat and to use. This is a vital dimension of quality. “Cleanliness and attending sanitation school are crucial. If I would not eat my

product, I will not sell it," says one producer.

While it is legally required in some states to be certified as a food handler in order to sell certain products, all producers should be familiar with the basics of food safety. Just one case of illness that could have been caused by the product is often enough to put the small operator out of business entirely.



### *Follow demand-driven production*

*"Find your market first and make sure that the market fits what you're already doing."  
— a salad mix grower*

"See what other companies do, but don't emulate them too closely. Innovate, don't copy; pick out only what they're doing right. Find your market first," adds the salad mix grower. When asked whether marketing considerations affected their choice of value-adding activity, eleven of the fourteen respondents said yes.

In agricultural marketing, there are the "push" and the "pull" approaches. The "push" approach means producing a product, and then "pushing" it onto consumers—the traditional means of marketing many commodity crops. The "pull" strategy, however, is increasingly becoming the norm in today's environment. With this approach, products are "pulled" out by consumer preference. It appears that most of the producers employed this "pull" approach and looked for an existing market outlet or opportunity, rather than producing a product and then looking for markets.

The presence of farmers' markets in the producers' area was an especially strong inducement to begin producing. As we've learned, farmers' markets are a good testing ground. Some of the respondents test-marketed or were actually asked to develop products by buyers. Generally there was an attitude of producing to meet the needs of the consumer.

Of those who did not let the market dictate their choices of activity, most started small and learned about niches they could fill.

A cheesemaker says, "I didn't know what our market would be. We prepared for mail order and wholesale options, but we never pursued them because the on-farm market developed so quickly. We never had to try any other marketing strategies. Really, we just developed our own marketing style, depending on customer requests, such as adding crackers, wine, and jams to our product line. Now all our milk goes to the on-farm cheese business."



### *Value Adding on a Larger Scale*

A producer of organic packaged jasmine rice says, "We began our value-added enterprise as a way to diversify and because with low commodity prices, to continue farming, we had to make more money. We researched for six months beforehand, looking at different crops. We decided to grow specialty rice organically—a new variety and new technology. We try new varieties all the time.

"The hardest part of planning was not knowing how much we could sell. Looking back, we should maybe have written a business plan, but we didn't know what we were getting into! We knew how to grow rice, but didn't know anything about packaging and marketing. We got help from the agricultural economics department at Texas A&M and the folks at the Rice Research Station came up with the gift bag idea.

"The state agriculture department was very helpful with legal issues. Being certified organic complicates things, but we've found it to be a very effective marketing strategy. We find that most sustainable and organic associations are oriented to small producers, which is not helpful for us. Organic rules are not a good fit for large-acreage commodity crops.

"Lack of knowledge in marketing was our biggest problem in getting started. The state agriculture department and the USA Rice

Federation gave us marketing assistance. We participate in the 'Taste of Texas' state-labeling program. Our labels also say that the product was produced on a family farm, is organically certified, and that the rice is a special variety. We find that these labels do help sales. The processing facilities are not on-farm; we contract with a rice miller and packager. We offer 2- and 25-pound packages. We need more information on packaging options; in fact, that is one of our biggest challenges since packaging is so expensive.

"We have a diversified customer base. About 75% of our product is marketed wholesale through brokers and distributors – 50% to the health food industry and 25% to mainstream retailers. Food service accounts for about 5% and mail order 20% of our total sales. We added mail order after five years. We were getting a lot of publicity in food magazines, and people were requesting our product, but there was no retail distribution in many areas. We do have some problems with mail order, since the weight of rice really adds to shipping costs. We also had to hire some additional help since we needed someone to take and fill mail orders and handle the extra office work involved.

"Our biggest management problem now is more competition from large companies. My advice to other aspiring value-added producers is to make sure your product is unique. It has been a great experience, but again, it's very difficult to compete now in the grocery industry."

spreading the word of mouth about their products.

A maker of jams, jellies, preserves, hot sauces, and baked goods can attest to the importance of getting the whole family involved. Two of her children are attorneys and they helped her write the business plan and get the enterprise incorporated, as well as research the legal requirements for her business. She says, "Planning was a lot of fun. My husband was formerly a chemical engineer, and he did the recipes and kept a notebook of calculations. He also takes care of financial management, including taxes."

When asked about the number and type of people involved in the value-adding enterprise, most had two people, and most of the rest had more than three, or only one – the respondent him- or herself. Most of the people involved were family members or part-time workers. Over half the respondents had made a change in the number of people involved since starting up. Nearly all respondents added labor as sales increased, although two respondents had scaled back production for various reasons, and likewise scaled back the number of people involved. As one respondent said, "Sales volume increased, but my energy decreased! I had to have help." Of those who had not changed the number of people involved, one got more efficient equipment to take the place of labor. Lack of adequate, affordable labor was identified as a constraint by many of the producers.



### *Get the whole family or partners involved*

Although no one identified this as a key specifically, during interviews the importance of family and partner involvement became clear. The people we interviewed made the most of the different skills and talents available in the family. Spouses with skills in accounting were essential to many of the enterprises. Nearly everyone we talked to had involved family, friends, co-workers and so on in





## *Adding Value to Beef*

A beef producer says, “ I market my beef direct to the consumer and through some local stores. I got into value-adding after going to a sale barn. I never wanted to go there again! I wanted some control over the price and I knew I wouldn’t get fairly compensated at the sale barn. I like doing something different, but if I’m spending time and energy doing something different then I should get extra revenue.

“As a first step in planning, I did some advertising to see if I would get any response. I also did some research on feeds and how to finish the cattle. I got a lot of responses from the classified ads I placed, and started selling half and quarter beeves. Word of mouth helped attract new customers.

“Customers wanted separate cuts of meat, so I started doing that. I give away many pounds of hamburger, which brings in business, either directly or through building a relationship with the community in general. I’ve probably given away more beef than I needed to, but I think I help the community as much as they help me.

“Selling quarters proved too unwieldy – it was more work to get the same amount of revenue, and customers didn’t understand how much meat is in a quarter and thought they were getting ripped off. Now I’m thinking about only selling half and whole beeves, since selling separate cuts requires a lot more paperwork and effort.

“Labeling is part of my marketing strategy. My beef is labeled with our brand name and ‘raised hormone-free and antibiotic-free’, which I think helps in marketing by building recognition and making us a ‘name brand’.

“If I had it to do over, I would have planned more, especially for growth. I would have tried to get all the meat sold before slaughter, since I have difficulties in matching production and sales. It seems like you’re either a bad producer or a bad marketer.”



## *Keep informed*

“Farmers need to become more aware of value-adding. Be mobile – get into townships and share information, look into partnerships and cooperatives.”  
– a beef producer

“Your local, most experienced, best, friendly grower-processors – and visiting their place and taking pictures and notes – are the absolutely best resources,” says a flower grower.

Hands down, other farmers involved in value-adding were identified as the best information resources. Farm visits, telephone and e-mail conversations, and networking at conferences and other events can give you information and insights that you can’t get any other way. However, be aware that others may see you as competition and not be willing to share their knowledge. A good idea is to do as the salad mix grower did, and solicit information from a grower in another state who will not be threatened by you.

Trade shows are especially recommended for producers of specialty and gourmet products. A producer of specialty vinegars, dry spice mixes, and other condiments says, “In the first year, I loaded up the pickup and headed to [the nearest big city] with a list of shops that I got from a friend. We also relied on word of mouth. We tried to target high-traffic stores. I attended trade shows sponsored by the state agriculture department, which increased our statewide exposure. We now supply specialty and gourmet food shops, do mail order, and have supplied restaurants in the past. We also supply catalog companies. I don’t drive around in the truck anymore, but prefer to concentrate on trade shows for my marketing. For wholesale, trade shows are the most effective marketing strategy. There used to be wine festivals for retail, but that market is now saturated. We offer free garden tours as a draw. We now also have a presence on the Internet, with a retail website. We’re trying to increase sales. The upswing in the economy has helped a lot!”



## Plan for the future

“Do your research: ideally you would spend two or three years planning.” – a cheesemaker

“Fail to plan and you plan to fail” is a cliché for a reason—it’s true. Planning is often neglected since there’s no immediate payoff, but it is essential to success. Cindy Thyfault, president of Westar Trade Resources, a strategic marketing and new business development company in Amarillo, Texas, says, “Don’t fall into the trap of writing a [business] plan just to get a bank loan (3).” For small entrepreneurial companies the failure rate in the first 5 years is 90% (3)! Careful planning is crucial to avoid failure, or at least to minimize your losses as you learn.

You may or may not need a formal business plan, but you do need a strategic plan. This plan will define your business mission, your present situation, and where you want to be in the next few years. You will need to cover assumptions and risks, goals and objectives and how you will report progress. “Be realistic in terms of goals, pricing, and the limits of your time. Factor quality of life in there somewhere,” advises one interviewee. Another says “Start on a shoestring and remain flexible. Realize that the best-laid plans can go wrong and that things change. You need to roll with the punches.”

About half the respondents wrote a business plan to start with and another wrote one later in order to secure an expansion loan. While one respondent had previous experience in business and was able to write her own plan, and another had children who were able to write the plan, the others relied on sources such as Extension, the loan coordinator, the Small Business Development Center, and the local Economic Development Center. One respondent said that she just made it up and that it was as much a projection as a plan, in

which she included a worst-case scenario and operated under worst-case assumptions

If they had it to do over, only four said that they would not plan beforehand. One respondent said, “I don’t think I could have foreseen what I know now”. Of those who would have planned, the need to plan for expansion was mentioned by most. The growth of the business presents challenges to new entrepreneurs. A grain products manufacturer says, “Be careful what you wish for—I was inundated with orders! Prepare for issues related to a sudden increase in demand since the worst thing you can do is not be able to fill orders.” Only three people said that if they had it to do over, they would write a business plan. Two people mentioned that the only need for a plan was to be able to borrow money, since lenders usually require a business plan.



Most of the respondents did not think a business plan was necessary. A cheese maker, for example, says she didn’t plan beforehand but just fell into it: “The cheese business happened gradually. I wanted to maximize my efforts with the idea of only so many hours in the day.” She says she wouldn’t plan if she had it to do over again because

“my enterprise began as a path of spiritual growth.” She says, “I *did* write a business plan, but only to show the lender to borrow start-up money.”

The easiest parts of business planning seemed to be figuring out the production requirements; since the respondents were already producing, they were most familiar with these. Judging from what our interviewees had to say, farmers without previous experience often have real difficulty dealing with financial issues in planning. Asked what was the hardest part of writing a business plan, “putting real numbers in the plan”, in the words of one respondent, emerged as the main difficulty. There were difficulties in knowing which numbers to include and in finding or estimating accurate numbers. Projections of production volume are particularly difficult to

make. Another respondent said that just finding relevant information in general was hard and that you had to persevere and ask a lot of questions.

Once their businesses were past the start-up stage, marketing issues and competition posed the major barriers to success for respondents. One said she is trying to redesign her promotional materials to target the needs of new customers; another said that, "It's a letdown when sales deals fall through because my product does not have a long enough shelf life. I may need contracts in the future." Another producer said, "Competitors are using cheap vinegar in very fancy packages that sell better than my own high-quality vinegars."

Once their businesses were past the start-up stage, marketing issues and competition posed the major barriers to success for respondents. One said she is trying to redesign her promotional materials to target the needs of new customers; another said that, "It's a letdown when sales deals fall through because my product does not have a long enough shelf life. I may need contracts in the future." Another producer said, "Competitors are using cheap vinegar in very fancy packages that sell better than my own high-quality vinegars."

When asked about whether they had a marketing plan, about half the respondents said they did, although only three had prepared a formal plan. Those who had chosen their products based on market opportunity had plans, whether written or not. Some respondents said that they didn't need a plan, since experience and trial and error make marketing needs clear eventually.

Many respondents did not get much help with marketing, but rather developed their own approach with experience and talking to their customers and to other growers. A few of the respondents got help from state agriculture departments and economic development centers. One respondent tried taking samples into her state's small business development center, and never heard from them again. Publications such as *Growing for Market* were also mentioned. Some respondents had

previous experience in marketing outside of agriculture and were able to apply their experience to agricultural enterprises.



### *Continuous Evaluation*

"Stop and evaluate (be objective) periodically, to see if it's really WHAT you want to be doing and HOW you want to be doing it."  
— a cheesemaker and manufacturer of gourmet dinners

A plan that is not periodically reviewed is nearly useless. Your business is constantly changing and your plan must be reviewed and modified accordingly. The plan must be kept current for you to effectively measure your performance. "Be ready to change in mid-stream, as there is no way you can predict marketing," says an interviewee. As you gain more experience and knowledge, you should incorporate your new perspectives and insights into your planning. Be sure to keep examining your original goals and make sure that your business is still meeting your goals.

When asked about whether or not their goals had changed since they started, eight respondents said yes and six no. Those whose goals had changed seemed about evenly divided between growing the business and scaling it back in order to have more personal time. When asked what sorts of problems they face in managing their enterprises, it was clear that people are, in the words of one respondent, finding it difficult to "balance attention to the business with quality of life." Nearly thirty percent of the respondents said that this was their biggest problem. For example, one respondent said, "Then, my goal was to find anything that was profitable. Now, my goal is to expand my ongoing profitable business." However, another respondent said, "The point comes when I have to stop pushing the cart uphill. I've made a conscious decision not to grow past a certain point. "

Those whose goals have not changed have often learned a different perspective. As one respondent said “My attitude may have changed but my goals haven’t.” Others mention learning new ways to meet their goals: “the means to the end are evolving. Now I laugh at my initial business plan!”

A producer who started out making goat cheese decided to add gourmet dinners and a bed-and-breakfast operation. As she says, “I went from manufacturing a product toward more involvement with the community.” While she admits that she is not fully using her cheesemaking plant facilities, she explains, “I made a conscious decision to become more active with the local community in the direction of agritourism instead of expanding the cheese production.”

She keeps good records and once a year evaluates how well the business is meeting her goals. Her goals have changed since she started the business. “Ultimately my goal moved toward becoming more a part of the community. Being able to influence the community meant maintaining a higher profile in order to effect change.”



*Perseverance*

“Have a VERY deep well of perseverance. Do the business plan and take as much time as it takes before you invest a whole lot of resources in your enterprise. Financial backers will take you more seriously.”  
— a cheesemaker



Why is perseverance a key to success? It’s simple: most businesses take a long time to get established. The successful entrepreneurs we interviewed had been involved in adding value for an average of nine years, with five years being the least amount of time reported. In *Making it on the Farm*, the businesses profiled took from a minimum of about five years to over twenty years to become successful.

It can be tough finding out how to get started with adding value to your farm products. You will need a good deal of perseverance just to figure out how to produce the products, much less how to market them.



A cheesemaker says, “We always intended to process, but we did ship milk for a couple of years just to get a cash flow going. We wanted to have a household business and be able to work together. I learned what equipment we needed and how to set it up by visiting other processing plants, reading professional journals, and working with cheesemaking professional organizations. We worked closely with the health department on building plans to obtain their sign-off. Small-scale milk processing equipment was very difficult to find. I worked at an off-farm job to finance the equipment while my husband stayed home to build. There wasn’t much literature available to learn how to make cheese. I had to ‘hunt and peck’ for information. I did take a university course, but I’m mostly self-taught. We started making one kind of cheese then added varieties to meet market demand as I learned how to make them.”

Identifying your niche and building a customer base also takes time. You may have to do a lot of experimentation to find out what sells. Like any other good relationship, developing relationships with customers doesn’t happen overnight. You will need to keep approaching potential buyers despite the inevitable rejections. “Understand that no one wants to be the guinea pig to test your product acceptance. Be prepared to attend trade shows and seminars, advertise, and market to consumers for an extended period of time without profitability,” says Cindy Thyfault (3).

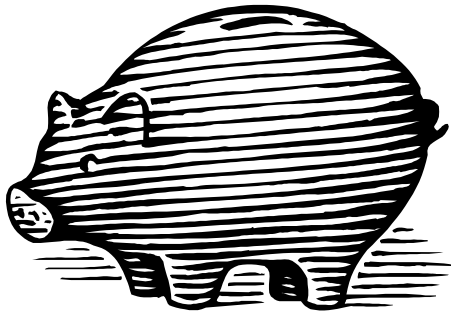

### *Adequate Capitalization*

“Be sure you don’t under-capitalize.”  
— *a specialty condiments producer*

A business is likely to operate at a loss for at least the first year of operation. Make sure you have adequate resources. Remember that most businesses fail due to lack of capital (2).

The amount that you’ll need will depend on the type of business. Manufacturing businesses will need more capital than service businesses. After figuring out how much you’ll need for your buildings and equipment, you’ll also need to have enough cash on hand to cover operating expenses for at least a year. Be sure to include some salary for yourself in the operating expenses. You will need to have enough money to live on until your business becomes profitable – which, as we’ve seen, can take years.

Successful marketing takes money. For many products, explains a producer of “gourmet” vinegars, “Upscale packaging is all-important to getting a jump on the marketplace, and you need adequate capital for packaging.”

“Labels can get really expensive for a small operation, especially in a humid, refrigerated environment. I’ve spent a fortune on labels,” adds a manufacturer of goat cheese. “I don’t know whether or not the labels have helped sales.”

Other costs can add up faster than you might think. Shipping and transportation issues present problems for many businesses. The vinegar producer says, “Dealing with UPS is

a problem for me. Their flat-rate charges are stacked against smaller businesses.”

While good planning can minimize unforeseen costs, no one can plan for every contingency. Your budget should include some funds for these costs. While you’ll need capital, make sure that you balance the need to plan for the unexpected with the need to minimize your debts. “Watch your debt load! People often buy the wrong machinery, which can be a very costly mistake,” cautions a producer. This is another reason to plan carefully and to start as small as you can, bearing in mind the production capacity that you may need in the future.

An extremely important form of capital is cash. Managing your cash flow is crucial to success; some say that cash flow is more important than profit. You can go a long time breaking even, especially if you remember to pay yourself rather than plowing every dollar back into the business. But if you fail to have enough cash to pay your suppliers, creditors, or your employees, you’re out of business!

Seasonal businesses, as many agricultural enterprises are, are even more vulnerable to running out of cash in the off season. This aspect of planning must not be neglected.

Wholesaling, while it’s not for everyone, can be a means of getting around seasonal cash-flow problems. For example, a goat cheese maker is now focusing on year-round wholesale cheese sales to retail and specialty stores, while building her agri-entertainment business during the spring and summer months. “Wholesale provides us with income to pay for the upkeep expenses we incur during the off-season (winter).”





## ***KEYS TO SUCCESS IN THE LONG RUN***

- ◆ Focus
- ◆ Establish a loyal customer base
- ◆ Choose something you love to do  
—*and* something that fits your  
Personality and goals

***“Make sure your product is unique. It’s very tough to compete with large companies on their turf, so identify a unique niche that you can fill better than the big guys are.”—a rice grower***



*Focus*

*“Don’t overextend yourself. Focus.”  
— a producer of herbal bodycare products*

“Educate yourself about your product and differentiating yourself in the marketplace,” advises a salad mix grower. “You need to be aware that the expectations of the public and the conventional business world are that your product is no different from any other product out there,” adds a cheesemaker.

To be able to both add value and capture that value for yourself, you’ll need to think strategically – what is your competitive advantage? A sustainable advantage is some aspect of your business that is unique and would be very hard for others to copy. Focus in on how to best use that advantage.

A cheesemaker says, “All our marketing is done direct to the consumer via on-farm sales. On-farm marketing is the best strategy for us, since our location is one of the last remaining agricultural pockets near a population center. It’s part of the culture of the area to drive out to farms, and our cheese is an exclusive item in the area. Differentiating yourself in the marketplace and educating your customers about your product are keys to success, I think.”

A salad mix grower says that he decided to produce salad mix because “it’s a narrow niche with high demand from gourmet restaurants and stores.” His previous experience in the business world made market development and planning target markets among the easiest parts of planning for him. He did some market research, and having received a favorable response to small test plots of salad mix, he decided to pursue the enterprise.

He started out by wholesaling, but found it unprofitable. “The least effective marketing strategy is wholesaling. If your strategy is to sell large amounts to very large corporate users, such as hotels or chains, and dealing with purchasing agents, you won’t succeed.”

He didn’t have a formal marketing plan: “My plan was only to sell all the product – or as much as we could – to end users and then to boutique grocers. Occasionally we discarded some. The best marketing strategy has been to emphasize our reliability and the freshness and quality of our product. Price is not an issue, although I have reluctantly dropped prices to get large accounts. We’re the only ones in the region growing this product. Our biggest problem now is achieving consistent production. In our climate, it is very difficult to predict actual production volume.”

“Recognize your limits in terms of vertical integration,” says another producer. You don’t have to, and often shouldn’t, attempt to do everything yourself. “Outsource your ingredients: it can be cheaper and it frees you up to do the crucial business of marketing,” advises a grower.





## *Adding Value to Grains*

A fourth-generation family farmer and manufacturer of non-perishable grain products (crackers, granola, cookies, dry soup mixes) says, “I think that if family farms are to remain viable, they have to diversify.” While that was her main reason for starting a value-added enterprise, an important secondary reason was that she wanted to work on the farm and quit commuting.

She got assistance in starting up the business and developing marketing and business plans from the Great Plains Area Vo-Tech Economic Development Center. However, she also did a great deal of research on her own on recipe formulation and adapting recipes to commercial-scale production, equipment, and regulations.

She says the hardest part of planning was “figuring out which hoops to jump through in terms of licenses, taxes, trademarks, and so on.” She thinks planning is crucial since “there are always surprises after the fact” and planning helps to anticipate and prepare for the unexpected. She learned about legalities from her state agriculture department’s marketing division. The only rules and regulations that have been a hindrance were those applying to making dog biscuits! She did have some difficulty getting a no-interest loan through the Economic Development Center: “It took nearly two years! I had given up.”

She sets prices based on production costs plus markup, which she calculated with input from friends in the food manufacturing business and what her competition – “high-end gourmet” – charges.

When asked how she decided how and where to market, she says, “Just having lived around here for a long time – I know the area and the local market. Word of mouth and some radio promos were helpful, but the major market for my baked goods and soups was my son’s restaurant, which went out of business a year ago.”

She started out by selling at a farmers’ market, but found that it was “not cost-effective to tie up two people all day. We did add to our customer base, though. It gave us exposure initially.” She originally made bread, but had too many problems with perishability. She still does an occasional large batch of bread for banquets or other special orders.

She tried marketing to local grocery stores, but found that “stores here aren’t geared to sell gourmet products.” Now she’s in the process of developing an online store. She says, “Yahoo offers website development and online ordering for \$100 a month. Yahoo also offers volume discounts on UPS shipping costs.”

She capitalizes on her family farming history and has developed a line of products that she markets under one brand. She participates in a state logo labeling program, which she feels definitely helps generate “substantial” in-state sales. For gift baskets, in particular, “it’s important that they’re made in-state.” The combination of her own story and customer loyalty to the state represent a great example of sustainable competitive advantage.



### *Establish a loyal customer base*

“My marketing activities evolve from year to year. There is one constant: the value of face-to-face interactions with customers at shows and market.” – *a producer of herbal bodycare products*

One of the most important ways that our interviewees capitalize on their uniqueness is through *relationship marketing*. Since every human being is unique, this makes a lot of sense. No one else can do exactly what you do,

in the way that you do it, when part of what you are marketing is you and your particular operation.

“Our relationships with our clients are the most important and we do everything on a very personal basis,” explains one producer. Another says that her most effective marketing strategy is “having a personal relationship with the buyer – a relationship of trust over time.” A producer of baked goods and jams says, “One of the most effective marketing strategies that we use is to do favors at the end of the season. We give special gifts to all our regular customers, and do special gift packages for people.”



One thing our successful farmers have in common is that they provide more than just food or a product. They also provide pleasant social interactions, a chance to get in touch with the rural way of life, education, and services. Some of the ways our respondents have provided “more” include tours of gardens or farms, bed and breakfast accommodations, gourmet dinners on-farm, and educational workshops on the farm. An herb grower and producer of herbal personal care products says, “Workshops on the farm bring people in to buy my other products.”

A cheesemaker includes a brochure and recipes with her products, but does not include labeling as part of her marketing strategy, since it is too costly. She finds word-of-mouth and direct contact with customers to be the most effective marketing strategies. “Direct contact builds a personal relationship. Our customers feel like they are also our friends. We hold an annual open house to build new relationships and add to our mailing list, as well as to reinforce existing relationships.” She finds “any kind of broadcasted mailings, newsletters, and the like that are not targeted to previous customers” to be the least effective marketing strategy.

Relationships aren’t limited just to customers. Build relationships with regulatory officials, educators, suppliers, and other growers, too.

well. A producer of specialty vinegars, dry spice mixes, and other condiments says, “I developed a good relationship with the local food inspector, which really helped in figuring out the appropriate technology and packaging to use. The state land-grant university’s food science department was also very helpful in solving technical problems.”

One producer says his key to success is “Quality control, fair price, and dependability at markets. You need to be there when you’re expected. In general I try to follow the golden rule [treat others as you wish to be treated].” You never know when you may need help, and if you’ve built solid relationships, these people will go out of their way to help you. It’s a good idea to conduct business treating everyone you meet as a potential customer.



*Choose something you love to do  
—and something that fits your  
personality and goals*

“Love what you do; live with intention;  
always learn; don’t forget to play.”  
—a producer of herbal bodycare  
products

Not surprisingly, most respondents’ primary motivation for beginning value-adding activities was to make more money. Some mentioned dissatisfaction with wholesaling and other market outlets that were unprofitable and offered the producer no control over pricing. Three respondents did mention non-monetary reasons such as developing their local Farmers’ Market, encouraging environmentally sound living, and encouraging local consumption of local products. Diversification was an important secondary motivation — to minimize risk as well as maximize income — as was being able to stay on the farm and meet lifestyle goals.

When asked about what they consider keys to success today, a common theme that emerged

among this group of farmers was that they love what they're doing. Whether it's making cheese on-farm, producing herbal beauty care products, or growing certified organic rice, all these farmers started with a passion for their product.

Why is this so important?

Producers say they want to make more money – so why not just identify a product or service that is known to be profitable, in high demand, and so on, and go with that?

Well, there are a lot of reasons. First of all, establishing an enterprise takes time and hard work. "The time between start-up and actually making a profit is usually a whole lot longer than you think it will be," says one of our interviewees. Without that passion, it's difficult to find the energy and motivation to stick with it. Will you be able to eat, breathe, and sleep your enterprise for several years? If not, perhaps it isn't the right business for you.



The farmers we interviewed stress the importance of doing what you love, but caution that *how* you go about turning that love into value-adding enterprises must fit your personality and your goals. "Value-adding would probably work best for farmers who are comfortable with doing their own marketing and dealing directly with customers," said one producer.

While there are many ways to add value to farm products without necessarily getting into consumer-direct marketing, the fact is that marketing activities account for the largest



share of the food dollar, and represent the largest potential for farmers to capture more value. Even if the ultimate goal is to sell the product through grocery stores or other retail outlets, the farmer still has to do the "behind the scenes" work that leads to that product being stocked and available.

Your sincere enthusiasm and belief in your product are part of what makes you unique. Produce quality products that you can be proud of, and set your prices to reflect that quality. You may be convincing a reluctant customer at the farmers' market to try a new vegetable, or convincing a reluctant manager at your local grocery store to stock your salsa. Enthusiasm is contagious!



## Resources

Producers and producers' associations were mentioned by five respondents as the resources that were most helpful in solving start-up problems. Four respondents mentioned printed materials, such as technical production manuals, trade publications, and, as one respondent put it, "encouraging and enthusiastic articles in magazines about similar types of products."

State agriculture departments and economic development agencies were mentioned by three respondents, as was the local board of health and health inspectors, and university assistance. Two respondents mentioned lenders. Others mentioned that they tried to problem-solve before they started and one respondent said he didn't rely on any resources since "experience is better than books."

Some of the *least* helpful resources for solving start-up problems were (each mentioned by two respondents) Extension, universities, and governmental small business and regulatory agencies. Some of the respondents' comments were: "Extension doesn't have much information in this area, but directed us to professional journals and organizations," and, "The local Extension encouraged us to start, but had no technical information for us." On universities, one respondent said, "University people tended to be unhelpful while thinking they were helpful."

Least helpful management resources were the small business development agencies, with two respondents of the six who answered this question mentioning them. One respondent said, "Small business agencies that purport to help, don't. It seems like the people with answers don't want to share." Extension was also mentioned as not being very helpful – "they need to be strategic thinkers and they aren't."

One respondent had hired someone to manage the enterprise, which turned out to be "a big mistake." Another respondent mentioned that most sustainable and organic agriculture associations were too oriented towards the small-acreage and/or specialty crop growers, which was not helpful for her as a large scale commodity crop producer. Overall, few respondents had an answer for this question, since, as one said, "Everything helps a little, at least."

Other producers and businesspeople – "how the other companies do it" – were the best management and marketing resources found. Four respondents put others involved in their industry at the top of the list. Three respondents mentioned both technology, especially the Internet, and reading.

As one respondent said, "The Internet is a great resource for its knowledge base and communications as well as the marketing possibilities." Others mentioned establishing retail Web sites and using technology to become more efficient.



Some printed materials our interviewees recommended include the periodicals *Acres USA*, *Stockman Grass Farmer*, and *Growing for Market*.

The Texas Department of Agriculture and Texas A&M were said to be extremely helpful with marketing. Organizations that were singled out as being especially useful included the Oklahoma Economic Development Center, Southern SAWG, ATTRA, and the American Society of Cut Flower Growers. Other resources that were mentioned included business consultants, financial experts, trade shows, and experience.

### ***Some other resources, in producers' own words:***

"Expeditors for labeling can be replaced by the industrial development authority; RC&Ds [Resource Conservation & Development] and IDAs [Industrial Development Authorities] are good resources since they have connections that can help farmers."

"*Cheesemaking Made Easy*; government agencies, especially new state grants for former tobacco growers; schools for pickles, jam, etc. for smaller-scale producers."

"Reading IRS materials for accounting and talking to other businesspeople."

"The best thing to do is to look at existing operations and seek help from University processing centers, as they are usually very free with information."

"*Stockman Grass Farmer*, *Acres USA*, Rodale Press pubs, authors such as Eliot Coleman, Wendell Berry, Paul Hawken, Jane Goodall; any organic association."

"In Oklahoma, the system of Vo-Tech with attached Economic Development Centers has a worldwide reputation; State Agriculture Department market development people; Internet sites."





## About the Farmers

### Demographics:

State	Number
Arkansas	3
N. Carolina	3
Virginia	2
Alabama	1
Kentucky	1
Louisiana	1
Texas	1
W. Virginia	1
<b>Total</b>	14

All respondents were caucasian. Of those who gave their age category, five were between ages 41-50, two were between ages 31-40 and one was 51-60.

Respondents' average distance from the nearest town was 10.2 miles. Average population in the nearest town was 42,800 but this ranged widely, from 600 to 275,000. Average distance from the nearest town of 50,000 or

more was 41.9 miles, with ranges from 5 to 110 miles. Four of the fourteen didn't have Internet access.

The average time involved in farming was 14 years, with a range from 5 to 25 years; average years in value-adding was 9 with a range from 5 to 15 years.

Income From Value-Adding	Number in Income Category
\$5001-\$10,000	3
\$10,001-\$25,000	1
\$25,001-\$50,000	3
\$50,001-\$100,000	3
\$100,001-\$500,000	3

Value-adding activities were very important to total farm income. Except for one respondent who said the business was a "hobby", these activities accounted for an average of 75% of all farm income. There was a definite split, however, with 8 of 14 respondents who said the activities accounted for 80% or more offarm income, and the remaining respondents who reported 50% or less.

Types of value-added products included (in order of frequency. Note that some respondents are doing several of these):

*Condiments* (jam, jelly, hot sauce, vinegars, seasonings) (5)

*Baked Goods* (pies, biscuits, cookies, etc.) (4)

*Cheeses* (3)

*Entrees* (jambalaya/bean soup mixes) (2)

*Health/Beauty* (soap/bath, lip balm, hand cream) (2)

*Salad mix* (packaged for retail)

*Beef* (hormone/antibiotic-free)

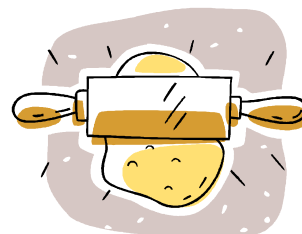
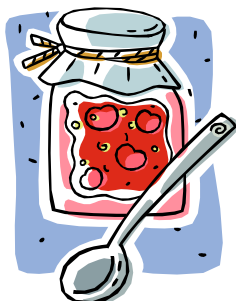

*Rice* (packaged organic jasmine)  
*Popcorn* (popped, whole-kernel, nuts/syrup)  
*Crafts* using on-farm inputs  
*Cut flowers*  
*Pickled foods*  
*Agri-entertainment* (B&B, tours, workshops)

Most have on-farm processing facilities and these were financed about 50-50 by the producers' own funds and by loans. One person said, "The hard part (of setting up the facility) was finding the money." Respondents learned about what was needed and how to set it up from other producers, and to a lesser extent from printed materials. The cheesemakers said that it was very difficult to find sources of small-scale, affordable equipment, but others did not mention it as a problem.

USDA inspection was only applicable for beef and cheese operations, and all but one cheesemaker provided a USDA-inspected product. It appears that this was to comply with the law and not for marketing purposes.

Almost every producer relied on several marketing outlets except three who only used one outlet. The outlets in order of frequency:

- Farmers' markets (6)
- Mail order (6)
- Direct to stores (specialty shops) (5)
- Direct to restaurants (3)
- On-farm sales (3)
- Festivals/shows/conferences (2)
- Wholesale (2)
- Internet (2)
- Distributors/brokers (2)
- Word of mouth (2)
- Home delivery (2)

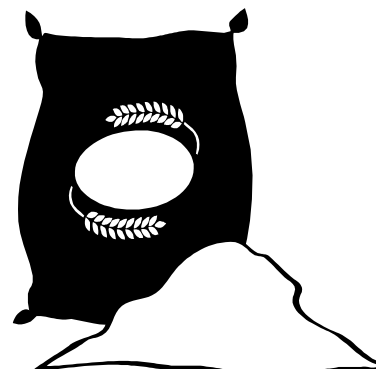

## References:

- 1) Dr. John Ikerd. "Re: sustainable and profitable— A bit long." Posted to sanet-mg electronic discussion group, 23 June 1998.
- 2) Sullivan, Robert. Small Business Truisms. Available on the Internet at: <[www.businessbookpress.com/articles/article118.htm](http://www.businessbookpress.com/articles/article118.htm)>. Excerpted from: Sullivan, Robert. 1997. The Small Business Start-Up Guide: Practical Advice On Starting And Operating A Small Business. 320 pages. Available from Business Book Press for \$19.95, s&h included. 800-363-8867.
- 3) Thyfault, Cindy. 1996. Developing New Generation Co-ops: Getting Started on the Path to Success. Rural Cooperatives. Vol. 63, No. 4

The Electronic version of **Keys to Success in Value-Added Agriculture** is located at:  
[www.attra.org/attra-pub/keystosuccess.html](http://www.attra.org/attra-pub/keystosuccess.html)

The ATTRA Project is operated by the National Center for Appropriate Technology under a grant from the Rural Business-Cooperative Service, U.S. Department of Agriculture. These organizations do not recommend or endorse products, companies, or individuals. ATTRA is located in the Ozark Mountains at the University of Arkansas in Fayetteville at P.O. Box 3657, Fayetteville, AR 72702. ATTRA staff members prefer to receive requests for information about sustainable agriculture via the toll-free number 800-346-9140.







# Adding Value to Farm Products: An Overview

A Publication of ATTRA - National Sustainable Agriculture Information Service • 1-800-346-9140 • [www.attra.ncat.org](http://www.attra.ncat.org)

By Holly Born and  
Janet Bachmann  
NCAT Agriculture  
Specialists  
©2006 NCAT

## Contents

Introduction.....	1
Capturing Value and Creating Value .....	2
Starting a Food Business .....	3
Farm and Food Business Profile: Persimmon Hill Berry Farm .....	6
Non-Food Options .....	7
Keys to Success .....	9
References .....	10
Further Resources .....	11
Resources for Starting a Food Business.....	11

This publication discusses the concept of adding value to farm products, the differences between creating and capturing value, and the implications for value-added enterprises. It describes some different approaches to adding value, including starting a food processing business, with a brief look at non-food products. Resources to learn more about value-added agriculture and planning a value-added enterprise are included.



*Oats, barley, and some products made from them.  
Photo by Peggy Greb. Courtesy of USDA/ARS.*

## Introduction

As farmers struggle to find ways to increase farm income, interest in “adding value” to raw agricultural products has grown tremendously. The value of farm products can be increased in endless ways: by cleaning and cooling, packaging, processing, distributing, cooking, combining, churning, culturing, grinding, hulling, extracting, drying, smoking, handcrafting, spinning, weaving, labeling, or packaging. (1) Today, more than ever, adding value means “selling the sizzle, not the steak.” The “sizzle” comes from information, education, entertainment, image, and other intangible attributes.

Because of the many regulations involved with food processing, some people may choose to add value in other ways. On a larger scale, producer-controlled processing for energy, fiber, and other non-food uses are options. On a smaller scale, items such as flower arrangements, garlic braids, grapevine wreaths, willow baskets, wheat straw weavings, sheep and goat milk soaps, and wool mulch are a few examples. In addition, ideas for providing entertainment, information, and other services associated with direct marketing are abundant.

Besides offering a higher return, value-added products can open new markets, create recognition for a farm, expand the



market season, and make a positive contribution to the community. However, adding value is not a panacea for all the problems rural America is facing. It is a long-term approach, not a “quick fix.” It requires the willingness and ability to take on risk, as well as adequate capital, management skills, and personal skills—such as the ability to interact with the public—to succeed.

## Capturing Value and Creating Value

Brees et al. (2) make the distinction between a strategy to capture value and a strategy to create value. This distinction is important to understand, because each strategy offers specific opportunities and risks that influence the success or failure of the value-added venture.

For producers, capturing value usually means capturing some of the value added by processing and marketing. For example, the producer’s share of the food dollar has seen a steady decline since 1900. (3) In 2005, the average farmer’s share of the food dollar was 22 cents, down from about 33 cents in the 1970s. (4) The rest of the food dollar goes to processing, distribution, and marketing. More and more, producers are attempting to increase their share of that food dollar by engaging in activities such as direct marketing to consumers, turning farm products into food products, and joining producer alliances and cooperatives that invest in facilities to process their farm products on a larger scale.

Marketing directly to the consumer can be done on a small or large scale and in a variety of ways. Options for the producer who enjoys direct contact with consumers include selling at farmers’ markets and through community supported agriculture systems. Other options include sales directly to restaurants and local institutions, as well as mail order and Internet sales.

Large scale processing through producer alliances, such as agricultural co-ops or limited liability companies, has seen growing interest among producers. These

alliances can offer a way to pool resources and manage risks. In some cases, producers lose marketing or processing facilities when corporate agribusinesses close local facilities. For example, when Iowa turkey farmers lost an Oscar Mayer processing plant and feed mill, the producers formed Iowa Turkey Growers Cooperative and purchased the facility in 1996. (5) The Iowa Turkey Growers Cooperative continues to produce and market whole and further-processed turkey products year round. Research from Purdue University (5) shows that producers do stand to benefit from diversifying into a value-added business related to the producer’s product, when the product is characterized by volatile prices at the farm-gate level but relatively steady prices at the wholesale or retail level. The turkey industry is such an example, and turkey producers benefited from diversifying into processing. In many cases, such as livestock processing, economies of scale can make it impractical for producer alliances to own the entire processing plant, if the alliance is not able to support an operation large enough to achieve those economies.

With a captured-value strategy, producers may face lower production risks, because production processes are well known and often linked to traditional agricultural production. Even when producers themselves are not familiar with processing, expertise in those areas can be hired. Captured-value ventures face an extremely competitive marketing environment, where demand is high, cost and efficiency considerations are paramount, and high volumes of products must be processed in order to gain efficiencies of scale. These ventures are often turning commodities into different commodities and, while value is added, it may not actually be captured by the producer.

For example, producer-owned cooperatives have attempted to enter the wet corn milling industry. However, this industry is extremely concentrated, with the top three firms having more than 80 percent of the market share for corn sweetener, one of the most important wet milling products, and similar market shares for the other wet

### Direct Marketing Publications from ATTRA

Direct Marketing

Farmers’ Markets

Community Supported Agriculture (CSA)

Selling to Restaurants

Bringing Local Food to Local Institutions

Marketing Strategies for Farmers and Ranchers

milling products. In this case, one commodity, corn, is being turned into another commodity, corn sweetener, and the producer cooperative faces a marketing environment in which it is almost impossible to compete successfully. Indeed, two of the most recent producer-owned cooperatives that attempted to enter the wet milling market, American Crystal Sugar's ProGold facility and Minnesota Corn Processors, could not compete and ended up being acquired by the top three firms. (5) For more information on getting off the commodity treadmill, request *Moving Beyond Conventional Cash Cropping* from ATTRA.

A created-value strategy, on the other hand, relies on products or services that are unique or different from the mainstream equivalent. These often include a real or perceived quality attribute such as organic certification, a brand image, identification with a specific geographic region and/or producer, identity preservation, environmental stewardship, and so on. Creating value can pose higher production risks than capturing value. It usually requires learning new production and marketing skills, dealing with food safety, labeling, and other regulations, and coping with liability issues and insurance. Demand for the innovative product or service must usually be created through advertising, promotion, and consumer education, and this is a lengthy, expensive process. Marketing risks may be lower with a created-value strategy, for if this demand can be established, there is potential for higher, stable prices and little direct competition. Contract agreements for identity-preserved products such as high-lysine corn reduce competition from other producers, for example. On-farm events and activities offer a unique setting that cannot be copied by other producers. However, producers will need to learn new marketing skills, carefully assess feasibility, and develop marketing plans for created-value products or services without established marketing channels.

The amount of value that can be added is affected by whether the enterprise is capturing or creating value. Brees et al. (2) cite

two different approaches to adding value to soybeans—a cooperative venture in a crushing plant, using a captured-value strategy, and producing a new “soy nut” product, using a created-value strategy. The crushing plant in their example added about \$1 per bushel from the meal and oil produced. The crushing plant faced narrow profit margins and stiff competition, common challenges for captured-value ventures, where the processing and marketing risks are relatively low.

Producing soy nuts that retailed for \$3.95 per 9-ounce package, on the other hand, added almost \$420 of value per bushel. While the markets for soybean meal and oil are very large, the market for soy nuts, and thus the total amount of value added, is very limited. Product and market development and compliance with food safety and packaging laws all require time and money. However, for the small-volume producer who cannot compete with the large-volume producers on price, targeting niche markets with a created-value strategy offers the highest likelihood of success.

Many producers combine aspects of both capturing and creating value in their ventures. A producer may create an unusual food product, such as local specialty bread, and sell it at the farmers' market, capturing more of the food marketing dollar. Food processors may use organic or unusual ingredients, and so on.

## Starting a Food Business

The food business is extremely competitive and dominated by a few large companies that are driven by cost and price considerations. Food is considered a “mature” industry, which means very little growth in demand. Food manufacturing continues to face narrowing margins and decreasing profits. Retailers are wielding more and more power over food wholesalers and manufacturers, and requiring manufacturers to pay more for shelf space (“slotting fees”), bear more of the product development risk, and provide product uniformity and quality. Smaller processors could have trouble

### Food Processing Publications from ATTRA

Grain Processing: Adding Value to Farm Products

Oilseed Processing for Small-Scale Producers

Edible Soybean Production and Marketing

Food Dehydration Options

Sorghum Syrup

Value-Added Dairy Options

## Case History:

### Value-Added Agriculture

From *Our Future's on the Table* (6)

Radiance Dairy, Francis and Susan Thicke, owners, Fairfield, Iowa

Former Minnesota dairy producers Francis and Susan Thicke have operated Radiance Dairy in Fairfield, Iowa, since 1992. When they took over the herd of Jersey cows—a breed that produces high-butterfat, high-protein milk that receives a premium price—the Thicques added more value by turning the dairy into an organic operation.

Today, 99 percent of their organic whole, skim, and two-percent milk, as well as cream, yogurt, and a soft cheese called Panir, are sold under the Radiance Dairy label by three local grocery retailers. Chocolate- and vanilla-flavored soft-serve ice cream is sold in restaurants. Other products such as new yogurts and cheeses are in development.

What does value-added mean to the Thicques? According to Francis: “Value-added products have features that go beyond what is generally found in the conventional market. Most people think value-added means processing raw materials into a finished product. That’s true, but value-added can be more than that. We believe organic products are value-added because of the extra care that goes into making the product. Radiance Dairy products really have two value-added features: they’re organic, and they’ve been processed to deliver additional value to our customers.”

finding outlets for their products, if they cannot meet scale requirements by the large retail operations that dominate the industry. In this mature industry, the only real growth is in niche food markets, where producers create value by adding special services for consumers, offering quality attributes like organic certification, specialized health products, and so on. They are able to charge prices 30 percent or more over mainline markets. Industry analysts agree that these markets are likely to continue to grow. (7)

The National Association for the Specialty Food Trade (NASFT) defines “specialty foods” as follows:

Foods, beverages, or confections meant for human use that are of the highest grade, style, and/or quality in their category. Their specialty nature derives from a combination of some or all of the following qualities: their uniqueness, exotic origin, particular processing, design, limited supply, unusual application or use, extraordinary packaging or channel of distribution, the common denominator of which is their unusually high quality. (8)

For more information and resources on the specialty foods industry, visit the National Association for the Specialty Food Trade’s Web site at [www.specialtyfood.com](http://www.specialtyfood.com).

Consumers with special dietary needs—both for specific health conditions and the general health concerns of our aging population—offer more opportunities for new products. For example, there are more than two million Americans with life-long, incurable celiac disease, who must avoid all gluten (from wheat, rye, and barley) in their diets. Gluten-free foods have been difficult to find and remain expensive, but for celiac disease sufferers, they are well worth the effort and expense. (9) For more information on health conditions requiring special diets, and the companies supplying these special foods, visit [www.specialdiets.org](http://www.specialdiets.org).

Other specialty foods options that have paid off for producers include production and marketing of unusually colored or shaped, “heirloom,” and “ethnic” crop varieties (request the ATTRA publication *Specialty Vegetables* for more information). Livestock can also be marketed as a specialty food, often in conjunction with religious or cultural celebrations and festivals or events, to use in traditional recipes. For example, meat goat and sheep producers have the options of serving many ethnic markets and providing special products such as sheep for the Muslim Ramadan holidays and cabrito (young goat) for the Hispanic Easter market. Some producers even offer buyers facilities on farm to slaughter according to Halal or other religious requirements.

Some of the main challenges in food processing include developing formulations and preparation schedules, dealing with regulations and regulatory agencies, product coding and labeling, and product liability insurance. (10) Researching the market potential for food products is a crucial first step. You will need to have a good idea of who will buy your product in the amounts and prices that will generate a profit for you. For more information on market research, visit [www.agmrc.org/agmrc/business/](http://www.agmrc.org/agmrc/business/)

[startingbusiness/marketresearch.htm](#), and see the **Business Planning Resources** section below.

Once you have an idea for a food product that you believe will appeal to consumers in the marketplace, you need to develop a detailed description of your product. This description should include where you will get all ingredients, a formulation (recipe), a method of preparation, processing procedures, and packaging. Revealing the amount of each ingredient or the spices in your formulation is not necessary. This should remain secret and be revealed only to federal or state regulatory agencies. Reliable suppliers for equipment, ingredients, and other supplies are critical to the operation of a successful food processing business. Identification of reliable suppliers is an important step prior to beginning your business.

If you are uncertain about any of the details needed in this plan, check with your county Extension office to see whether you can get help from your land-grant university. Most have a department of food science or food technology, with staff who can help you in the initial stages of product development. If you work with a food technologist to develop your product or process, you will be asked for your complete formula. This information will remain confidential.

Bring as many details about your product as you have, including a sample. The product will be evaluated and classified regarding the type of processing needed. This classification will be based on the product's acid and water contents.

Transferring recipes for food products made in small batches or in a home kitchen to commercial-size formulas that can be manufactured in larger batches using commercial equipment is not an easy task. Frequently, simply multiplying ingredient amounts to get larger-size batches does not result in a product comparable to that made with smaller recipes. Plan on contracting with a state-approved facility, such as a private-label manufacturer, to manufacture a fairly large quantity of your best formulation(s). This

will give you an opportunity to revise and adjust your formula so that your final product is exactly the way you want it. Most private-label manufacturers can also provide formulation assistance. The county health department may be able to help you with information about such facilities located in your county.

A key point to remember is that adding value by processing food products increases safety risks. Therefore, rules and regulations are established to protect the public health. Each state has its own regulations about processing kitchens, and some local governments have building codes that also apply. If there is any possibility that you will be selling your food out of state, you must also comply with the federal regulations as stated in the Federal Food, Drug, and Cosmetic Act and enforced by the Food and Drug Administration (FDA). The FDA has what it calls Good Manufacturing Practices (GMP), upon which state regulations are based. GMPs include requirements that walls, floors, and ceilings be washable, and the kitchen must be ventilated so that drip or condensation from ceiling or fixtures won't fall into food. Food contact surfaces, tools, and equipment must be resistant to corrosion and made of non-toxic materials. Seams on surfaces must be smoothly bonded to prevent accumulation of food particles, dirt, etc. The room must be screened to keep out birds, insects, and other pests. You must have a bathroom, if you have employees. You must have a hand-washing sink separate from sinks for washing, rinsing, and sanitizing equipment and utensils. Water must be from an approved source.

If your food product contains more than five percent meat, you must have a USDA Food Safety and Inspection Service inspector present during processing. You must also comply with USDA regulations, whether the product is sold in-state only or out of state. The full description of GMPs is printed in the Code of Federal Regulations 21 CFR, Part 110, available on-line at [www.access.gpo.gov/nara/cfr/index.html](http://www.access.gpo.gov/nara/cfr/index.html).

**A**dding value  
by process-  
ing food  
products increases  
safety risks.

All products need to include a product code that shows where the product was packed, the date and year packed, and the product and batch number. Individual containers and cases should be coded. The codes should be kept in records pertaining to the product and should be written on your invoices to identify distribution. The codes provide a means of tracking a product, should there be complaints or a recall be necessary. Organic processing involves additional record-keeping and other regulatory requirements.

The label is the means by which consumers identify your product, so time and thought should be given to developing your label. Both the state and the FDA have very specific regulations concerning labeling requirements. Contact the appropriate agency regarding information you must include on the product label. The FDA requires nutritional labeling if you do more than \$50,000 in business annually. The regulations for nutritional labeling are quite extensive, with very specific requirements about information to include and the format for presenting this information. Details of these requirements can be obtained from any FDA office or the FDA Small Business representative.

If you plan to sell your product through retail stores, you should plan to display a Uniform Product Code (UPC) on the label. This bar code provides a means for automated identification of your product. Brokers, wholesalers, and retail buyers will not handle a product without a UPC. It is your responsibility to obtain a UPC for each product you produce. Contact the Uniform Code Council to apply for a UPC assignment. The fee for assignment is based on the size of your business. Contact:

Uniform Code Council  
937-435-3870  
937-435-7317 FAX  
[info@uc-council.org](mailto:info@uc-council.org)  
[www.uc-council.org/  
ean\\_uc\\_system/index.cfm](http://www.uc-council.org/eau_system/index.cfm)

While it can be difficult to find a liability insurance provider, and insurance may be

costly, product liability insurance is a must. Many farmers' markets and most retail outlets will require a minimum level (normally \$1 to 2 million) of product liability coverage before you can sell your products in their markets. There are no standard rates for liability coverage for food products, because the premium depends on the specific characteristics of the product, the manufacturing process, and marketing plan. Most insurance companies require a great deal of information—including submission of production, distribution, and marketing plans—even to provide a rate quote.

Product design and marketing tips are covered in more detail in *Fresh to Processed: Adding Value for Specialty Markets*. (11) Created as a training and resource tool for value-added processors, with funding from the North Central Region SARE program, *Fresh to Processed: Adding Value for Specialty Markets* provides an overview of the main aspects of starting a food business. Contact ATTRA for a copy of this resource.

## Farm and Food Business Profile: Persimmon Hill Berry Farm

The story of Earnie and Martha Bohner's Persimmon Hill Berry Farm shows what can happen when creative and persistent farmers team up with supporters from the state university, state department of agriculture, and many others.

Although both Earnie and Martha trained and worked in other professions, the small-farm lifestyle of the southern Missouri Ozarks appealed to them, and in 1983—starting with no buildings, no electricity, and no running water—the Bohners began developing their pastured hill land. They chose the name Persimmon Hill because the farm was covered with young persimmon trees. Within 10 years they were cultivating three acres of blueberries, an acre of blackberries, 2,000 hardwood logs for growing shiitake mushrooms, and 120 apple trees. (12)

Contact the FDA by mail, telephone, or Internet:

Food and Drug Administration  
5600 Fishers Lane  
Rockville, MD 20857  
1-888-INFO-FDA  
(1-888-463-6332)  
[www.fda.gov](http://www.fda.gov)

The berries were initially marketed to pick-your-own customers. The added value is the experience of a day on a farm with a friendly and helpful host. “We create a place where people can enjoy themselves,” Earnie says. Clean restrooms, a picnic table, and shade trees provide for the comfort of visitors to the farm. Keeping the field edges mowed and trimmed contributes to the clean image needed to attract visitors. “People don’t come all the way out here to get cheap food. They come because it’s fun, and the berries are absolutely fresh. As much as we can, we give them contact with ‘the farmers.’ The more we can do that, the more people go away with that memory.”

In 1986 the Bohners began adding value through processing. “After considerable study, we decided to turn ripe berries into full-fruit jams, although it would take more work than the U-pick operation and spread our management thinner,” says Martha. “From the first, we were committed to quality, and quality entails a lot of time and cost. Our recipe is simple: fresh, ripe fruit; sugar; natural pectin; a bit of lemon juice, and nothing else. We want our product to have a distinctive, berry taste.” Earnie and Martha worked with a chef to perfect recipes for other products such as shiitake mushroom sauce. The first products were prepared in rented kitchens, a good way to make the step without the cost of building your own kitchen. The Bohners now have their own processing kitchen on the farm, just a few steps from the blueberry patch. The business office and storage space are in the same two-story building. Processed products (their famous blueberry Thunder Muffins, a range of jams, shiitake mushroom sauce, blueberry and other barbecue sauces, dried shiitake specialties, a refreshing blueberry slush, and a cookbook) now account for a large share of the farm’s gross income. Processing fruits and shiitake mushrooms allows them to use produce that isn’t sold fresh, to extend the marketing season and to diversify their marketing outlets. The Bohners have sold as many as 1,400 Thunder Muffins in a single day, and Martha Bohner says the

muffins carry the farm through the unprofitable winter months. (13)

Direct marketing is another way to add value. In addition to U-pick and farm stand sales, the Bohners have created a Christmas gift mail-order market. Previous customers and gift recipients receive a mail-order folder describing packages that will be sent directly to them. The cover of the flyer features the farm’s black Labs shown watching St. Nick’s sleigh heading off into the Ozark night.

Business planning has been critical to the development of Persimmon Hill Berry Farm. Earnie tries to reorganize each January, after he reviews production and marketing records for the previous season. He adjusts long-range plans, sets goals for the next 12 months, and then breaks down jobs by two-week periods. Earnie says, “In an ideal situation, I would look at these goals monthly. On a daily basis, I have a list that I carry with me that supports the overall plan.” He is always looking for ideas for new products, niches, and services. In regard to finding help for business planning, Earnie says, “SCORE has been really helpful.” (SCORE, the Service Corps of Retired Executives, is a Small Business Administration program. For more information on SCORE, request the ATTRA publication *Agricultural Business Planning Templates and Resources*.) “We also have had graduate students from a university business department out here. It is a useful experience for them, and they can give a business owner another perspective. And we get lots of ideas from Ron Macher’s *Small Farm Today* magazine.” Beyond the financial aspects of the business, a visit to the farm will show anyone that a vision for a beautiful place in the country and love for life are driving forces. To pay a virtual visit to the farm, visit [www.persimmonhill.com](http://www.persimmonhill.com).

## Non-Food Options

The difficulty of coping with regulatory requirements, as well as the highly competitive nature and the relatively low margins of the food industry, have

“**P**eople don’t come all the way out here to get cheap food. They come because it’s fun.”

led many producers to consider non-food options for adding value to their farm products. Some of these non-food options are discussed below. Your options for adding value with non-food products and services are limited only by your resources and your imagination.

## Energy

Energy production from agricultural products is on the rise. It includes producing biofuels, such as ethanol and biodiesel, and electricity from crops, wastes, and wind. Producers may be interested only in reducing on-farm fuel costs by producing biofuels for their own use. Many producer groups, on the other hand, have invested in biofuels manufacturing as a way to add value to agricultural products such as corn and soybeans. The viability of many of these investments, such as corn producers investing in ethanol production, depends on government subsidies and programs. (5) The Agricultural Utilization Research Institute's Center for Producer-Owned Energy offers useful information on many biofuels options on their Web site at [www.mncpoe.org](http://www.mncpoe.org). The ATTRA publication *Biodiesel: a Primer* not only describes the process of making biodiesel on-farm but also provides further resources on many aspects of renewable energy. For more information on energy and agriculture, visit ATTRA'S Energy and Agriculture section at [www.attra.org/energy.html](http://www.attra.org/energy.html).



Many farm machines at ARS' Beltsville Agricultural Research Center run on a mixture of diesel fuel and biodiesel, which is made from soybean oil.  
Photo by Bob Nichols.  
Courtesy of USDA/ARS.

## Fiber

Organic cotton fiber is enjoying a developing market (14); however, these markets are still limited and subject to competition from imported cotton. For more information on organic cotton, request *Organic Cotton Production* from ATTRA. There are also small niche markets for naturally colored cotton. The increasing consumer interest in hand spinning, knitting, and weaving has led to increased marketing opportunities for sheep and goat producers for organic, naturally colored, hand-made wool, yarns, and other products, as well as finished goods such as blankets and clothing.

## Wood

Woodlot enterprises, both timber and non-timber, may offer another option. Request a copy of *Woodlot Enterprises* from ATTRA for more information. Another good place to start investigating woodlot enterprises is the WoodWeb at [www.woodweb.com/KnowledgeBase/KBIndex.html](http://www.woodweb.com/KnowledgeBase/KBIndex.html).

## Personal Care Products

Adding value to products such as milk, honey, and wax by producing soaps, lotions, and other personal care products is a popular option. The market for "natural" personal care products reached \$5 billion in 2004, increasing by more than 50 percent since 2000, and should continue to grow. (15) Learn more about natural personal care products at [www.soap-wire.com](http://www.soap-wire.com).

## Farm Entertainment

According to Agriculture Specialist Katherine Adam, in *Entertainment Farming and Agri-Tourism*, "While the popularity of specific enterprises—such as pumpkin patches or U-pick orchards—may ebb and flow, the public's desire for a 'farm experience' remains."

Small diversified farms are ideally suited to agri-entertainment. Unlike the mega-hog facility or a corn/soybean operation producing bulk commodities, the small farm can recreate an earlier, simpler, human-scale vision of



farming. The chief qualification for the rural landowner who expects to make a living from the land through agri-tourism is the desire and the ability to cater to tourists and meet their expectations of a farm visit.

Request a copy of *Entertainment Farming and Agri-Tourism* from ATTRA for more information on many different options to add entertainment and educational value to your farm and farm products.

## Keys to Success

Although no simple blueprint for success exists when you're trying to add value to your farm products, a few general practices emerge from interviews with a number of southern farmers. No matter how you

end up adding value to your farm products, these principles apply.

- Start small and grow naturally.
- Make decisions based on good records.
- Create a high-quality product.
- Follow demand-driven production.
- Get the whole family or partners involved.
- Keep informed.
- Plan for the future.
- Evaluate continuously.
- Persevere.
- Capitalize adequately.
- Focus.

### Business Planning Resources

A comprehensive business plan that includes marketing and finances can help determine the feasibility of a value-added enterprise. Developing your business and marketing plan helps you define your business, creates a road map to operate the business, sets the goals you will aim for, and satisfies outsiders' requests for a written explanation. The basics of a business plan include the following.

What?	Describe your product or service.
Why?	Describe the need for your product or service.
Who?	Describe the customer.
When?	Draw a timeline and list all the tasks that need to be accomplished.
Where?	Describe the location of your business.

*Building a Sustainable Business: a Guide to Developing a Business Plan for Farms and Rural Businesses* helps alternative and sustainable agriculture entrepreneurs develop profitable enterprises. Sample worksheets illustrate how real farm families set goals, researched processing alternatives, determined potential markets, and evaluated financing options. Blank worksheets help producers develop detailed, lender-ready business plans and map out strategies to take advantage of new opportunities. It is available at no charge on the Internet at [www.misa.umn.edu/publications/bizplan.html](http://www.misa.umn.edu/publications/bizplan.html). Print copies are available for \$14 (plus \$3.95 shipping and handling charge).

To order copies, contact:

Sustainable Agriculture Publications  
210 Hills Building  
University of Vermont  
Burlington, VT 05405-0082  
802-656-0484  
802-656-9091 FAX  
[sanpubs@uvm.edu](mailto:sanpubs@uvm.edu)

Useful resources from ATTRA include:

*Agricultural Business Planning Templates and Resources*  
Sources of agricultural business planning templates and other resources.

*Enterprise Budgets and Production Costs for Organic Production*  
Sources of information on costs and returns of organic production.

- Establish a loyal customer base.
- Choose something you love to do *and* something that fits your personality and goals.

These points are described in detail in the ATTRA publication *Keys to Success in Value-Added Agriculture*. Call ATTRA to request a copy. The publication also provides farmer profiles and information about the resources that they found useful.

Adding value to your farm products can be a great way to increase farm income, diversify production, and enter new markets. Understanding the risks and rewards of different approaches to adding value, investigating the wide range of options for adding value, and thoughtful business planning are all important to success.

## References

1. Richards, Keith, and Deborah S. Wechsler. 1996. *Making It On the Farm: Increasing Sustainability Through Value-added Processing and Marketing*. Southern Sustainable Agriculture Working Group. 40 p. *Compiled from interviews with southern farmers and ranchers who are adding value to their products, it describes some of their practices, discusses 10 keys to success, and includes a list of resources. Available for \$12 (includes shipping and handling) from:*  
  
Southern SAWG Publications  
P.O. Box 324  
Elkins, AR 72727  
501-587-0888  
[ssfarm@lynks.com](mailto:ssfarm@lynks.com)
2. Brees, Melvin, Joe Parcell, and Nancy Giddens. No date. *Capturing vs. Creating Value*. MU Agricultural Guide, University of Missouri Cooperative Extension.  
[www.agmrc.org/agmrc/business/gettingstarted/capturingvscreatingvalue.htm](http://www.agmrc.org/agmrc/business/gettingstarted/capturingvscreatingvalue.htm)
3. Smith, Stewart. 1991. *Is There Farming in Agriculture's Future?* Presentation to College of Agriculture and Life Sciences. University of Vermont. November 14.
4. Anon. 2005. *Retail Food Prices Rise Slightly*. Pork magazine. April 4.  
[www.porkmag.com/directories.asp?pgID=678&ed\\_id=3305](http://www.porkmag.com/directories.asp?pgID=678&ed_id=3305)
5. Fulton, Joan. *Value-Added Business Ventures Through Producer Alliances*. 2003. Purdue University Cooperative Extension Service Publication ID-318.  
[www.ces.purdue.edu/extmedia/ID/ID-318.pdf](http://www.ces.purdue.edu/extmedia/ID/ID-318.pdf)
6. *Our Future's on the Table*. *The Web site of an Iowa consortium seeking to increase the value of Iowa farm products includes links to a number of case histories. Contact can also be made through the address below.*  
  
Ag Initiative 2000 Consortium  
200 East Grand Ave  
Des Moines, IA 50309  
515-242-4805  
515-242-4832 FAX
7. Sparks Companies, Inc. 2003. *Top-Down Competition in the Food Industry: Trends and Implications*. Strategic Forum Discussion Paper. Sept. 23. 46 p.  
[www.mda.state.mn.us/ams/whitepapers/topdown.pdf](http://www.mda.state.mn.us/ams/whitepapers/topdown.pdf)
8. *Food Industry Resources & Worksheets. Product Development: Identifying Your Market Segment*. Appalachian Center for Economic Networks (ACEnet) Food Ventures Web site.  
[www.acenetworks.org/frames/framesfoodventures.htm](http://www.acenetworks.org/frames/framesfoodventures.htm)
9. Choi, Candice. 2005. *Gluten-Free Market Goes Mainstream*. Associated Press. July 27.
10. Brady, Pamela, et al. 1997. *Starting a Food Business*. Institute of Food Science and Engineering. University of Arkansas, Fayetteville, AR. 6 p.
11. Durham, Deni. 1996. *Fresh to Processed: Adding Value for Specialty Markets*. Missouri Organic Association, Ashland, MO. 33 p.
12. Bohner, Earnie. 1998. Personal communication with Janet Bachmann.
13. Anon. 2003. *True blue: Loyal berry fans line up across Missouri to get a taste of summer's sweetest treat*. Columbia (MO) Daily Tribune. June 29.  
<http://archive.columbiatribune.com/2003/jun/20030629feat004.asp>

14. Dimitri, Carolyn, and Catherine Greene. 2002. Recent Growth Patterns in the U.S. Organic Foods Market. U.S. Department of Agriculture, Economic Research Service, Market and Trade Economics Division and Resource Economics Division. Agriculture Information Bulletin Number 777. 42 pp.  
[www.ers.usda.gov/publications/aib777/](http://www.ers.usda.gov/publications/aib777/)
15. Anon. 2005. Three Years of Double-Digit Growth Powers the Natural Personal Care Market to \$5 Billion. Soap Wire Online. June 22.  
[www.soap-wire.com/2005/06/three\\_years\\_of\\_.html](http://www.soap-wire.com/2005/06/three_years_of_.html)

## Further Resources

### General Value-Added

#### The Ag Marketing Resource Center (AgMRC)

*(www.agmrc.org) is an excellent electronic, national resource for producers interested in value-added agriculture. This comprehensive Web site offers information on value-added opportunities for agricultural commodities and products, market and industry trends, learning how to create and operate a business, research results of value-added markets and businesses, and how to locate national, state, and local value-added resources. A comprehensive set of directories, including agricultural innovation centers, consultants, service providers, and value-added businesses that can be contacted by individuals with similar interests, and specific resources for all 50 states, is available at [www.agmrc.org/agmrc/directories/](http://www.agmrc.org/agmrc/directories/).*

Hamilton, Neil. 2000. The Legal Guide for Direct Farm Marketing. Drake University Law School. Des Moines, IA. 235 p.  
*This book is an excellent resource to help you begin the process of learning about the rules and regulations that may affect you. Prepared under a grant from the USDA Sustainable Agriculture Research and Education Program, it is available from:*

Agricultural Law Center  
Drake University Law School  
507 University Ave.  
Des Moines, IA 50311  
[www.law.drake.edu](http://www.law.drake.edu)

One great source of innovative, farm-tested ideas for adding value and generating more income is FARM SHOW magazine. For more information, contact:

Circulation Department  
FARM SHOW  
P.O. Box 1029  
Lakeville, MN 55044  
800-834-9665  
952-469-5575 FAX  
[circulation@farmshow.com](mailto:circulation@farmshow.com)  
[www.farmshow.com](http://www.farmshow.com)

Another source of ideas is *Small Farm Today* magazine. For more information, contact:

Small Farm Today  
3903 W Ridge Trail Rd  
Clark, MO 65243-9525  
573-687-3525  
573-687-3148 FAX  
800-633-2535  
[smallfarm@socket.net](mailto:smallfarm@socket.net)  
[www.smallfarmtoday.com](http://www.smallfarmtoday.com)

#### USDA Rural Business-Cooperative Services

*offers two grant programs for value-added project development. The Section 9006 Renewable Energy System and Energy Efficiency Improvement Grants provide grants and guaranteed loan funds to farmers, ranchers, and rural small businesses looking to finance a renewable energy or energy efficiency project. Visit [http://attra.ncat.org/guide/n\\_z/renewable.html](http://attra.ncat.org/guide/n_z/renewable.html) for more information. The Value-Added Producer Grant program makes grants available to independent producers and producer groups for planning activities to establish a viable value-added marketing opportunity for an agricultural product or for acquiring working capital to operate a value-added business venture. Visit [http://attra.ncat.org/guide/n\\_z/value\\_added.html](http://attra.ncat.org/guide/n_z/value_added.html) for more information.*

## Resources for Starting a Food Business

In addition to the directories available at the AgMRC Web site mentioned above, there are some other resources that are especially helpful for starting a food business.

### **Appalachian Center for Economic Networks**

**(ACEnet)** runs the Food Ventures program, which works with entrepreneurs in their service area in the southeastern Ohio area to create and grow specialty food businesses. ACEnet also offers excellent advice and information on their Web site at [www.acenetworks.org/frames/framesfoodventures.htm](http://www.acenetworks.org/frames/framesfoodventures.htm) for anyone interested in the specialty foods business.

**Better Process Control School (BPC)** is required by federal regulations for any supervisors of low-acid food thermal processing systems and container closure operations. It is strongly recommended that anyone involved in any phase of food processing who is not familiar with the principles of food preservation attend this school. Several universities hold a BPC school at various times during the year. To locate a BPC school near you and learn about the many other training resources available, contact:

Food Processors Institute  
1350 I Street, NW  
Suite 300  
Washington, DC 20005-3305  
202-639-5945  
800-355-0983 (toll-free)  
202-639-5932 FAX  
[fpi@fpa-food.org](mailto:fpi@fpa-food.org)  
[www.fpi-food.org](http://www.fpi-food.org)

### **The Fooddude's Food Marketing 101** at

<http://www.fooddude.com/foodmarketing101.htm> is an on-line resource designed primarily for potential manufacturers or marketers of specialty food products. The purpose is to pose questions (and provide some answers) for those interested in producing food products for sale. Included is information about retail trade channels; distribution channels; product positioning, branding, packaging, and pricing; packaged food sales; marketing and promotion; customer service and data use; as well as links to general resources and food industry associations.

### **Getting Started in the Food Specialty Business**

[www.efsonline.uga.edu/EFS\\_NFB/  
New%20Food%20Business%20Packet/  
Getting%20Started%20in%20the%20Food%  
20Specialty%20Business.pdf](http://www.efsonline.uga.edu/EFS_NFB/New%20Food%20Business%20Packet/Getting%20Started%20in%20the%20Food%20Specialty%20Business.pdf)

Hall, Stephen F. 1992. From Kitchen to Market: Selling Your Gourmet Food Specialty. Upstart

Publishing, Chicago. 190 pp. ISBN-0-926894-34-2.

*A good resource to determine whether your food product has potential.*

### **Exploring the Potential for New Food Products**

[http://msucares.com/pubs/publications/  
p2170.html](http://msucares.com/pubs/publications/p2170.html)

### **Starting a Value Added Farm-Food Business**

[www.uwex.edu/ces/agmarkets/](http://www.uwex.edu/ces/agmarkets/)

#### **Adding Value to Farm Products: An Overview**

By Holly Born and Janet Bachmann  
NCAT Agriculture Specialists  
©2006 NCAT

Paul Driscoll, Editor  
Cynthia Arnold, Production

This publication is available on the Web at:  
[www.attra.ncat.org/attra-pub/valueovr.html](http://www.attra.ncat.org/attra-pub/valueovr.html)  
and  
[www.attra.ncat.org/attra-pub/PDF/valueovr.pdf](http://www.attra.ncat.org/attra-pub/PDF/valueovr.pdf)

IP141  
Slot 136  
Version 032206



[www.attra.ncat.org](http://www.attra.ncat.org)

### CURRENT TOPIC

By Lance E. Gegner  
NCAT Agriculture Specialist  
August 2001

Dairy farmers can add value to their milk by processing and marketing their own products, such as cheeses, yogurt, butter, ice cream, and farm-bottled milk. Many consumers are willing to pay a premium for locally produced, high-quality, farmstead dairy products; organic certification may further enhance the market potential.

Developing a product line, production facilities, and a niche marketing strategy will take time, money, and commitment. It is unlikely that the enterprise will be profitable in the first three to five years. Additional skills beyond producing milk will be required. Here are some basic questions dairy producers need to ask themselves before they get into processing and marketing:

- Do I have the resources to do this?
- Do I really want to do this?
- Do I have the experience, people skills, and information to do this?
- How much profit potential is there with this enterprise?
- How will I market the product and what is the customer base available?
- Do I have the financial resources needed to support this enterprise during the start-up period?

### Regulations

Dairy food processors – including small farms adding value to their own dairy commodities – are subject to a dizzying array of state and local regulations and inspections. Aspiring processors should check carefully with regulatory authorities for specific requirements during the planning stages of the enterprise, and once again as the equipment is ready to be installed. Some states may have training requirements for persons intending to process dairy food products.

State and local regulatory agencies have primary responsibility for enforcement of sanitation requirements on dairy farms and at dairy processing plants. Producers must contact their Department of Agriculture (Department of Health in Arkansas) for specific regulations and requirements before proceeding with any other steps. The National Association of State Departments of Agriculture has a directory at [http://www.nasda-hq.org/nasda/nasda/member\\_information/gen\\_main.htm](http://www.nasda-hq.org/nasda/nasda/member_information/gen_main.htm). A more general listing of all state and local regulatory agencies by state is available at the FDA's *Directory of State Officials 2001* at [http://www.fda.gov/ora/fed\\_state/directorytable.htm](http://www.fda.gov/ora/fed_state/directorytable.htm).

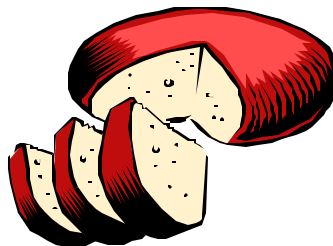

Law professor Neil Hamilton's 235-page *Legal Guide for Direct Farm Marketing* is a good source of information about laws on marketing products directly to consumers and to retail and wholesale buyers. It was written to address producers' questions about the legal aspects of direct farm marketing. The book provides many contacts and resources across the U.S., including state and federal inspectors, organizations, and others. The cost of the book is \$20.00. To order, contact Drake University Agricultural Law Center, Des Moines, IA 50311, (515) 271-2947.

## Organic Milk

At the time of this writing, the National Organic Program (NOP) is scheduled to begin implementation of the Final Rule for national organic standards in September 2002. As of this date, any producers seeking initial certification will have to comply with the requirements of the Final Rule. Producers who are already certified (by an agent that has received USDA accreditation) will have to achieve compliance with the NOP standard at their next annual inspection. For additional information on organic certification, request ATTRA's *Organic Certification & The National Organic Program* or visit NOP's website and review the Final Rule's standards for organic dairy production at <http://www.ams.usda.gov/nop/nop2000/nop2/finalrulepages/finalrulemap.htm>.

Demand for organic milk and milk products continues to grow nationwide. The *Organic & Natural News* article "Return to the Golden Age of Dairy" (1) states:

According to SPINS/ACNielsen, the organic dairy industry has experienced tremendous growth in almost every category it tracks. Organic milk gallons have taken the gold medal with a 148.8-percent increase in the 12 months ending July 2000 compared to the previous year. Other categories have made incredible leaps as well. Sales of organic cottage cheese and ricotta have risen 53.58 percent with packaged organic cheese, organic butter and organic sour creams trailing closely behind; all posted increases in the 30-percent range.

The growing demand for organic dairy products is driven primarily by consumers' belief in the higher quality and safety of these products, and their awareness of the positive environmental, animal welfare, and ethical impacts of organic agricultural practices. Many are concerned about the use of antibiotics and of rBST (recombinant bovine somatotropin), a genetically engineered Bovine Growth Hormone that is injected into an estimated 30 percent of lactating cows in conventional dairies. These are some of the reasons why consumers choose organic dairy products despite higher prices (2).

Organic milk comes from cows that are not given any hormones, antibiotics, or pesticides. They have access to open pastures and are fed 100-percent organic feeds—grown in fields that are chemical-free for at least 3 years. Organic milk must be handled separately from conventional milk and never intermixed. Organic milk and milk products must be processed, either on-farm or off-farm, in a certified organic plant.

**Other ATTRA publications that will help you to plan  
for value-added production and direct marketing:**

*Adding Value to Farm Products: An Overview*

*Keys to Success in Value-Added Agriculture*

*Direct Marketing*

*Alternative Meat Marketing*

*Evaluating a Rural Enterprise.*

## Sources of Further Information

The state Department of Agriculture is the best source of help and information. The producer will need to comply with state law first; everything else is secondary.

An excellent source of information is the Hometown Creamery Revival Project. This project is funded by the Sustainable Agriculture Research and Education (SARE) program of the USDA and managed by Ms. Vicki Dunaway. The Hometown Creamery Revival promotes on-farm processing as a means of making dairying a sustainable way of life for small farms.

Currently the project produces a quarterly newsletter, *CreamLine*, and maintains a list of equipment suppliers, events, and links to relevant websites at <<http://metalab.unc.edu/creamery/>>. A free sample issue of *CreamLine* is available on request. The subscription cost is \$22.00 per year or \$40.00 for two years. For more information, visit the project's website or contact:

Vicki Dunaway  
Hometown Creamery Revival Project  
P.O. Box 186  
Willis, VA 24380  
(540) 789-7877 (before 9 p.m. Eastern)  
E-mail: ladybug@swva.net

The first major publication of the Hometown Creamery Revival, *The Small Dairy Resource Book*, is a 56-page annotated bibliography of books, periodicals, videos and other materials on farmstead dairy processing. These resources cover such topics as on-farm cheese, ice cream, butter, and other dairy processing; business and marketing; food safety and feeds; and grazing. This publication is available online at <<http://www.sare.org/handbook/dairy>>. To order a printed copy, visit <<http://www.sare.org/san/htdocs/pubs/>> or send \$8.00 plus \$3.95 for shipping and handling (check or money order) to:

Sustainable Agriculture Publications  
Hills Building, Room 10  
University of Vermont  
Burlington, VT 05405-0082  
(802) 656-0484 (to order with Visa or Master Card)

Artisan Cheesemakers Listserv is the original email list for discussing the production, marketing, and history of handcrafted and artisan cheeses, as well as other dairy products. For additional information visit <<http://members.xoom.com/cheesemaker/Cheemakers-L.htm>>, or to subscribe <[Artisan\\_Cheesemakers-subscribe@yahoogroups.com](mailto:Artisan_Cheesemakers-subscribe@yahoogroups.com)>.

In March 2000, the Dairy Creamery Listserv was started. This mailing list was created for small, grass-based, traditional dairy farms and for small-scale processors who are pasteurizing and bottling milk, or making value-added products such as cheese, yogurt, cream, or ice cream, and who are selling either on-farm or within their regions. To subscribe to dairycreamery, send email to <[dairycreamery-subscribe@yahoogroups.com](mailto:dairycreamery-subscribe@yahoogroups.com)>.

The April 2001 issue of *Ag Innovative News*, from the Agricultural Utilization Research Institute in Minnesota, did a special series focusing on producer-owned dairy processing. The series of articles included "Bottle at your own risk," "Pasturing for profit," "The milk-fed economy," and "Bittersweet end." These articles focus on feasibility studies showing that the prospects are dim for newcomers to enter the current well-established milk processing and distribution system. However, the studies do show niche marketing opportunities in the natural foods market. These articles are available on-line at <<http://www.auri.org/news/ainapr01/contents.htm>>.

Many electronic resources are available to those with Internet access (see **Further Resources: Websites** below). Several book suppliers are also listed in the **Further Resources** section.

### References:

- 1) Belongie, Laurie. 2000. Return to the golden age of dairy. *Organic & Natural News*. October. 7 p. <<http://www.organicandnaturalnews.com/articles/0a1Feat2.html>>.
- 2) Hayhurst, Chris. 2000. Got organic milk? The natural dairy business is going mainstream. *E-Magazine*. May-June. 3 p. <[http://www.emagazine.com/may-june\\_2000/0500gl\\_eating.html](http://www.emagazine.com/may-june_2000/0500gl_eating.html)>.

### Enclosures:

Dunaway, Vicki. 2001. One more new cheese plant on the planet. *CreamLine*. Summer. p. 1, 3-5, 12-19.

Hamilton, Neil D. 1999. Direct marketing unpasteurized milk from the farm. In: *The Legal Guide for Direct Farm Marketing*. Drake University Agricultural Law Center, Des Moines, Iowa. p. 199-201.

Major, David. 2001. The land of cheese marketing: Don't get caught without a paddle. *CreamLine*. Summer. p. 11.

Nation, Allan. 2001. Selling organic milk isn't as easy as it looks. *The Stockman Grass Farmer*. August. p. 22.

Smith, Barb and Steve Smith. 2001. Reviving the creamery – Marketing. *Organic Farms, Folks, & Foods*. Mid-Spring. p. 17-19.

Bernhard, Mike. 2001. Dairy opportunities??? *Organic Farms, Folks, & Foods*. Mid-Spring. p. 19-20.



## Further Resources

### Websites:

#### Organic Dairy Information

<http://www.nysvga.org/webpages5/cdcramer/profiles/arnold.htm>  
Profile of an organic dairy farmer in New York.

[http://www.iowafarmer.com/010324/niche\\_dairy.htm](http://www.iowafarmer.com/010324/niche_dairy.htm)  
Article on an organic dairy-processing farm in Iowa.

<http://www.organicandnaturalnews.com/articles/0a1Feat2.html>  
Article about the marketing potential of organic milk.

[http://www.emagazine.com/may-june\\_2000/0500gl\\_eating.html](http://www.emagazine.com/may-june_2000/0500gl_eating.html)  
Article about the marketing potential of organic milk.

<http://www2.gov.pe.ca/af/cornerpost/april99/link7.asp>  
Article about a Horizon Organic Dairy farm in Maryland

#### Cheese Information

<http://www.cheesesociety.org>  
The American Cheese Society website listing conferences, articles, and their latest newsletter.

<http://www.cheesereporter.com>  
The Cheese Reporter Magazine website has an excellent searchable supplier directory, a large book and video selection, and lots of links to other websites.

<http://www.efr.hw.ac.uk/SDA/cheese2.html>  
Excellent site on the basics of making cheese.

<http://www.erols.com/auraltech/index2.html>  
Website with useful links on cheesemaking and on different cheeses.

### Books and Supplies:

New England Cheesemaking Supply Company  
P.O. Box 85  
Ashfield, MA 01330  
(413) 628-3808; Fax: (413) 628-4061  
<http://www.cheesemaking.com>

*Has information on cheesemaking, an on-line catalog for supplies and books, and many links.*

Kitchen Arts and Letters, Inc.  
1425 Lexington Avenue  
New York, NY 10128  
(212) 876-5550  
<http://www.kitchenartsandletters.com>  
*Has a large selection of books on cheeses and cheesemaking.*

*Organic Dairy Farming*  
Kickapoo Organic Resource Network  
Community Conservation, Inc.  
50542 ONE Client Lane  
Gays Mills, WI 54631  
(608) 735-4717  
*Cost is \$8.00 postpaid.*

## IDEA



## Direct Marketing Lamb to Niche and Ethnic Markets

Initiative for the Development of Entrepreneurs in Agriculture

Andrew Larson  
Evelyn Thompson

## Introduction

Lamb accounts for 93-96% of total U.S. sheep meat production (see Table 1 for the differences between types of lamb and mutton). In 2001 and 2002, weighted average retail prices of domestic lamb were \$4.28 and \$4.33 per pound, respectively (O'Dell et al.). Direct marketing of agricultural products is one strategy for producers to capture a larger portion of consumers' food dollars by eliminating commissions and fees for middlemen who provide services along the conventional food supply chain. It is especially useful for producers with small flocks (Kazmierczak & Bell). However, the decision to market directly requires a producer to "know thyself" and "know thy market." This publication will deal with the direct marketing of lamb to ethnic and religious markets, including cultural preferences and times of high demand.

**Table 1. Classifications of Sheep Meat**

Type of Sheep Meat	Animal Description
Baby/Hothouse Lamb	Milk-fed, <10 weeks old, <20 lbs
Spring/Easter Lamb	Several months old, 20-40 lbs
Lamb	5-12 months old
Yearling/Hogget	1-2 years old
Mutton	>2 years old

Source: Hormel Foods

## Are You a Direct Marketer?

The first and foremost consideration with direct marketing is deciding whether or not a producer has the patience and disposition for the intensive management, aggressive marketing tactics, and extensive customer interaction that come along with it. Although it may be appealing to move from the role of 'price-taker' to that of 'price-maker', the lamb producer must also be prepared to personally provide or contract for services that would normally be rendered by middlemen, including slaughtering, breaking, packaging, storing, transporting, and promoting the product (Kazmierczak & Bell).

Even the most independent producer must keep in mind that it is not easy to eliminate every middleman. For example, only meat for personal consumption can be slaughtered and processed on-farm. By law, all meat products for retail sale must be slaughtered and processed at a meatpacking facility inspected and licensed by the state or federal government (federal inspection is required for meat sales across state lines). Such a facility can be built on-farm, but smaller producers without the volume or

capital to pursue this strategy generally opt to contract for custom slaughter with a nearby plant that can produce a consistent, high-quality product.

Above all, the successful direct marketer is an astute and tireless salesperson that is never too modest or aloof. A producer must explain what makes his or her lamb superior, be it breed, nutrition, quality of life, freshness, or a government-sponsored designation like "Certified Organic" that adds value to the product. In this time of raised consumer awareness regarding health and where food comes from, producers ought to sell their practices, their persona, and their farm as diligently as they sell their lambs. One should actively seek feedback to learn about customer preferences, even following up on lamb sales to ensure satisfaction (Kazmierczak & Bell). A direct marketer must be willing to adapt production to demand, but it helps to anticipate customer desires and expectations before the marketing even begins.



## Religious Markets for Lamb

There are a number of religious celebrations throughout the year for which lamb is a traditional part (see Table 2 for dates and types of lamb desired). As a matter of fact, religious and ethnic niches account for much of the total U.S. consumption (Jones), but a lamb producer must be prepared for the nuances that come along with marketing directly to religious niches. For instance, both price and supply of slaughter lambs tend to peak in the second quarter due to increased demand around the Easter and Passover holiday season (O'Dell et al.), but Western/Roman Easter and Eastern/Greek Easter may occur as much as a month apart, depending on the year. Marketing savvy is especially necessary when selling to Jewish and Muslim customers because they are frequent lamb consumers with specific dietary laws for which special

**Table 2. Religious Holidays that Call for Lamb**

Holiday	Religion	2005	2006	2007	2008	2009	Type of Lamb Wanted
Eid al Adha begins (Festival of Sacrifice)	Muslim	21-Jan	10-Jan	31-Dec	20-Dec	9-Dec	60-80 lbs
Passover begins	Jewish	24-Apr	13-Apr	3-Apr	20-Apr	9-Apr	30-55 lbs, milk fed and fat
Western/Roman Easter	Christian	27-Mar	16-Apr	8-Apr	23-Mar	12-Apr	30-45 lbs, milk fed and fat
Eastern/Greek Easter	Orthodox	1-May	23-Apr	8-Apr	27-Apr	19-Apr	40-55 lbs, milk fed and fat
Rosh Hashanah begins	Jewish	4-Oct	22-Sep	12-Sep	29-Sep	19-Sep	Forequarters from weaned lambs, 60-110 lbs
Ramadan begins (Month of Fasting)	Muslim	4-Oct	24-Sep	13-Sep	2-Sep	22-Aug	60-80 lbs
Eid al Fitr (Ramadan ends)	Muslim	3-Nov	24-Oct	13-Oct	2-Oct	21-Sep	60-80 lbs
Christmas	Christian	25-Dec	25-Dec	25-Dec	25-Dec	25-Dec	milk fed

Sources: Penn State Cooperative Extension, West Virginia University, Barbados Blackbelly Sheep Assn. International, Northeast Sheep & Goat Marketing Program, and the Interfaith Calendar

arrangements must be made.

People of the Jewish faith who keep a *kosher* diet have specific requirements for animal slaughter and meat consumption. Ruminants with cloven hooves, like lambs, must be killed by a specially trained slaughterer under rabbinical or special agency supervision. The animal's throat must be quickly slit with a perfectly honed knife and be allowed to drain completely of blood. The carcass is inspected to insure that bones and organs are completely

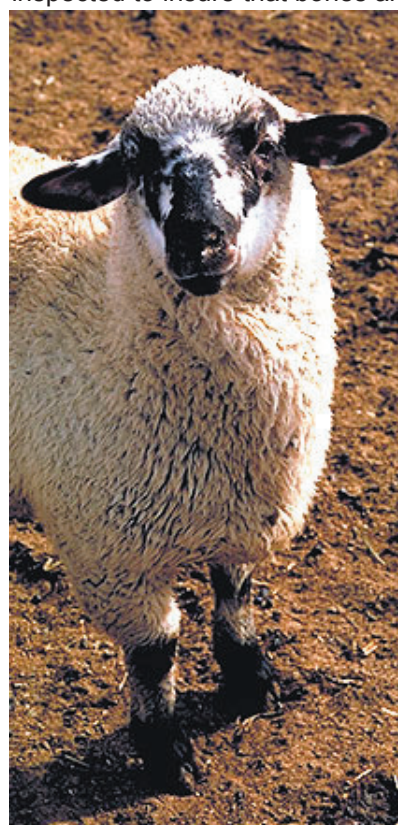

intact and that the lungs are free of abnormal tissue growth. The sciatic nerve, as well as certain fatty tissue and blood vessels, must be removed for the meat to be kosher, but due to the difficulty of this process many kosher Jews avoid the hindquarters of the animal altogether (Kazmierczak & Bell, Regenstein & Chaudry).

Muslim ritual slaughter, or *halal* slaughter, involves minimizing stress to the animal, turning its head towards Mecca, and speaking the *basmala* prayer (Kazmierczak & Bell). The throat is then slit and the blood thoroughly drained

from the carcass, as in kosher slaughter. Muslim holy days occur approximately eleven days earlier each Western year because the Islamic calendar, or Hijri. It is based on lunar cycles rather than solar cycles. Thus, lamb producers must be diligent in keeping track of this shift and having the lambs ready 7-10 days prior to the holiday (O'Dell et al.). Lambs that are blemished or very fatty may be discriminated against. Muslim customers may ask to perform the ritual slaughter at the farm on the designated day, so producers must decide whether or not to accommodate this type of request with the necessary space and equipment.

Places of worship may seem like logical marketing targets when trying to find religious holiday customers, but be sure to exercise a lot of tact when dealing with a culture that is unfamiliar. People often place a great deal of reverence in their place of worship and will not look kindly upon presumptuous advertising tactics. Talking to the head of the worship community and/or a sampling of its members will likely help determine the most appropriate way to publicize products and services a producer can offer, as well as creating an opportunity to learn more about lamb demand and preferences. Word-of-mouth advertising can be quite effective in close-knit communities, but news of a faux pas will also travel fast.

## Ethnic Markets for Lamb

Lamb consumption is not only associated with religions, it is also a staple food among people from specific parts of the world, especially those of Middle Eastern, African, Latin American, or Caribbean origin (Jones). Lamb is also very popular among Greeks and Basques (Kittler & Sucher). The typical lamb consumer is an older, relatively well-established ethnic minority from a metropolitan

area (Jones) who may be purchasing the lamb for fresh use or long-term freezer storage (see Table 3 for lamb size preferences of selected markets and Table 4 for weight and space requirements for dressed lamb). When determining where to begin,

it may be useful to find concentrations of specific races or immigrant populations in nearby townships, counties, and metropolitan areas. With a little practice, online tools like the U.S. Census Bureau's American FactFinder at <http://factfinder.census.gov/> or the University of Illinois' MarketMaker at <http://www.marketmaker.uiuc.edu/>, can help provide useful demographic information.

Aside from religion, the lamb producer must be prepared to deal with other cultural differences when marketing lamb directly to foreign-born customers, especially when doing so from the farm. If customers are used to choosing from a selection of products, a producer may be wise to separate "for sale" livestock from breeding animals so as not to have to repeatedly reject customers' choices. It is entirely possible to encounter customers that are accustomed to haggling over prices (Kazmierczak & Bell). Depending on personal disposition, a producer may or may not choose to take part in such negotiations, but those who choose not to ought to have a set price for all their customers and develop a clear, convincing argument about prices of production, living wage, etc., so customers do not come away feeling cheated (Stanton). Customers who feel this way will substitute less expensive items or even other meats.

Another possible route for reaching ethnic niche markets is marketing directly to specialized restaurants and food stores that cater to particular populations. Marketing to retail food establishments of any kind require diplomatic interactions with their meat buyers and a patient eagerness to please. Retail food businesses generally have conventional supply chains through which they acquire their meat, so a small producer must have a strategy for product differentiation, perhaps touting the quality benefits and sales potential of fresh, local, family-farmed, humanely-raised, natural, or organic lamb. Demonstrations of enhanced cooking quality, tenderness, or taste may also be convincing. In short, the buyer simply must be able to anticipate the payback for the

**Table 3. Lamb Live Weight Preferences for Selected Markets**

Market	Weight Preference
Italian	35-45 lbs
Greek	45-60 lbs
Muslim	60-90 lbs
Restaurant	80-100 lbs
Freezer Lamb	100-120 lbs
Kosher*	100-125 lbs
Wholesale	120+ lbs
*use forequarters only	

Sources: Northeast Sheep & Goat Marketing Program and West Virginia University

extra expenditure of time and money to deal with another supplier.

Primary research in Chicago has shown that some cultures have specialty stores operated by their own people that tend to be the first stop for certain items. For instance, some authentic Mexican markets will carry steamed lamb, leg of lamb, and stew meat. Greek shops will carry high-quality whole lambs for special feast days like Greek Easter, as well as leg of lamb, roasts, chops, and stew meat that may be pre-cut or prepared on demand by a butcher. Pakistani and other Middle Eastern shops that sell meat will carry halal lamb, which will often bring in customers of any nationality that is predominantly Muslim. Baby lamb, regular lamb, and mutton are all available and usually custom cut, with price having a major influence on purchase decisions. Bones, heads, organs, and variety meats are also available.

When such dedicated ethnic stores are not present or convenient in Chicago, people will often shop at large produce stores that devote most of their space to fresh fruits and vegetables, meat, cheese, bakery, and deli items. These large produce stores will often cater to specific ethnic groups in their area and carry the cuts, quantity, and quality of lamb that the culture demands for their traditional dishes and means of preparation. For instance, produce stores that serve East



European communities, like Bosnians, Russians, and Poles, or Mediterranean communities, like Greeks and Italians, will carry a large variety of high quality lamb portions that may be pre-cut and packaged or available for custom cutting at a specialty counter. Produce stores that serve Latin American or African and Caribbean communities will often have lamb available, but usually with less variety or range of quality.

Marketing to restaurants and mainstream stores that serve ethnic communities is also a possibility, but small producers may find requirements like year-round supply, high volume of product, and restrictions on which cuts will be purchased overwhelming. This type of marketing frequently necessitates employees, inspected slaughter and processing, and specialized equipment like refrigerated trucks (Kazmierczak & Bell). Producers may be able to meet these scale and resource requirements by organizing and marketing lambs collectively (O'Dell et

**Table 4. What to Expect from Freezer Lamb**

Animal	Avg. Slaughter Weight	Avg. Dressed Weight	Avg. Usable Meat	Freezer Space Needed
Lamb	100-160 lbs	50-80 lbs	40-65 lbs	1.5 cubic feet
Baby Lamb	40 lbs	20 lbs	20 lbs	0.5 cubic feet

Source: Virginia Tech

al.). This requires intense cooperation among producers and careful coordination of genetics, breeding schedule, nutrition, and processing in order to market a consistent, quality product. Point-of-purchase branding and labeling are also good strategies for differentiating product in the retail marketplace (Kazmierczak & Bell).

## Conclusion

If a lamb producer decides to put forth the effort to market directly to religious and ethnic niches, the key factor is to know the market. Marketing plans must be based on a thorough understanding of whom and where the customers are, their preferences for lamb, cultural distinctions, the overall demand for lamb, and how the producer is going to meet that demand in part or in full. Direct marketers must be capable of the extensive interpersonal communication and assertive salesmanship necessary to make the enterprise successful. They must also be prepared for a long learning curve and be willing to tailor their production to meet the needs of their customers. With this combination of forethought and flexibility, along with a bit of marketing savvy, lamb producers can develop a reputation for quality and customer satisfaction that will precede them and serve them well into the future.

### Online Lamb Marketing Resource Centers

AgMRC, Agricultural Marketing Resource Center - Livestock Products Page for Lamb & Goat. Available at: <http://www.agmrc.org/lambgoats/lambgoats.html>

ASI, American Sheep Industry Association. Available at: <http://www.sheepusa.org/>

LMIC, Livestock Marketing Information Center. Available at: <http://www.lmic.info/>

Maryland Small Ruminant Page – Sheep & Goat Marketing. Available at: <http://www.sheepandgoat.com/market.html>

Northeast Sheep & Goat Marketing Program. Available at: <http://www.sheepgoatmarketing.org/>

### Publications for Direct and Ethnic Meat Marketing

Alternative Meat Marketing. Holly Born for ATTRA, the National Sustainable Agriculture Information Center. Available at: <http://www.attra.org/attra-pub/altmeat.html>

Final Report of the West Virginia Lamb Marketing Information Project. Dwayne O'dell et al. for West Virginia Department of Agriculture. Available at: <http://www.ams.usda.gov/tmd/FSMIP/FY2001/WV0328.htm>

Goat and Lamb Holidays. Dr. & Mrs. Robert D. Herr for Penn State University. Available at: <http://bedford.extension.psu.edu/Agriculture/Lessons/Goat%20and%20Lamb%20Holidays.htm>

Humane (Halal) On-Farm Slaughter of Sheep and Goats Poster. Northeast Sheep and Goat Marketing Program. Available at: <http://www.sheepgoatmarketing.org/sgm/news/poster.htm>

Interfaith Calendar: Primary sacred times for world religions. Morgen Krueger Ltd. Available at: <http://www.interfaithcalendar.org/index.htm>

Marketing Out of the Mainstream: A producers' guide to direct marketing of lamb and wool. Tamra Kirkpatrick Kazmierczak and James B. Bell, Virginia Tech. Available at: [http://www.sheepusa.org/index.phtml?page=site/text&nav\\_id=b2de3dc862e2eb3f0d97238c91988c20](http://www.sheepusa.org/index.phtml?page=site/text&nav_id=b2de3dc862e2eb3f0d97238c91988c20)

Producing and Selling Sheep to the Ethnic/Religious Meat Markets. Susan Schoenian, University of Maryland Cooperative Extension. Available at: <http://www.blackbellysheep.org/articles/ethnicmarket.htm>

Trends in the U.S. Sheep Industry. Keithly G. Jones for the USDA Economic Research Service. Available at: <http://www.ers.usda.gov/publications/AIB787/>

### References

Jones, Keithly G. 2004. Trends in the U.S. Sheep Industry. USDA Agriculture Information Bulletin #787

Kazmierczak, Tamra K. and Bell, James B. No date. Marketing Out of the Mainstream: A producers' guide to direct marketing of lamb and wool. Virginia Polytechnic and State University.

Kittler, Pamela G. and Sucher, Kathryn P. 1999. Cultural Foods: Traditions and Trends. Brooks/Cole Publishing, California.

O'Dell, Dwayne; Marsh, Deborah J.; Singh, Doolarie; Plaughter, Georgette F.; Lewis, Paul E.; Inskeep, Keith; and Smith, Dennis. 2003. Final Report of the West Virginia Lamb Marketing Information Project. West Virginia Department of Agriculture, Marketing and Development Division.

Regenstein, Joe M. and Chaudry, Muhammad. No date. A Brief Introduction to some of the Practical Aspects of the Kosher and Halal Laws for the Meat Industry. Northeast Sheep & Goat Marketing Program.

Stanton, Tatiana. 2000. On-farm Marketing of Lambs and Slaughter Goats. Northeast Sheep & Goat Marketing Program.



For more information contact  
**Richard Knipe**  
 Phone: 309-792-2500  
 Email: [rknipe@uiuc.edu](mailto:rknipe@uiuc.edu)

# Marketing and Economics

## Additional Resources

### Books

#### **Building a Sustainable Business: A Guide to Developing a Business Plan for Farms and Rural Business**

DiGiacomo, Gigi, Robert King, and Dale Nordquist. 2003. Minnesota Institute for Sustainable Agriculture, Saint Paul, MN, and the Sustainable Agriculture Network, Beltsville, MD. 280 p.

Business planning is an important part of owning and managing a farm. Business plans help farmers demonstrate that they have fully researched their proposed enterprises; they know how to produce their products, how to sell what they produce, and how to manage financial risks. This comprehensive workbook will guide farmers through every step of the process in creating a business plan. Includes many examples from existing farms. This workbook is a bargain. Available for \$14.00 + \$3.95 S/H by calling 802-656-0484 or 800-909-6472. Publication can also be viewed and downloaded at [www.misa.umn.edu/vd/bizplan.html](http://www.misa.umn.edu/vd/bizplan.html).

#### **Small- Scale Livestock Farming: A Grass Based Approach for Health, Sustainability, and Profit**

Ekarius, Carol. 1999. Storey Books, Pownal, VT. 217 p.

Not specific to any species of livestock; contains farmer profiles and quite a bit of holistic planning and economic information. Very complete in treatment of rotational grazing.

#### **Making Money with Goats** Winslow, Ellie. 2005. Freefall Press. 193 p.

This book covers many ways to make money with goats, including information on general production, goat milk, meat, skins, fiber, and business planning.

#### **Turning Wool into a Cottage Industry**

Simmons, Paula. 1991. Storey Books, Pownal, VT. 188 p.

This book is a big help to those who want to use fiber.

#### **Changes in the Sheep Industry** National Research Council. 2008. The National Academic Press, Washington, D.C. 347 p.

A comprehensive report covering the history

and current state of the U.S. sheep industry. Also includes information on breeds, health issues, and marketing.

#### **Marketing out of the Mainstream: A producers' guide to direct marketing of lamb and wool**

Kirkpatrick, Tamra and James Bell. 1995. Sheep Industry Development Program. Englewood, CO. 57 p.

Available as a PDF from the American Sheep Industry Web site. See [www.sheepusa.org/Publications](http://www.sheepusa.org/Publications). This site also includes up-to-date reports about marketing, and the Sheep Care Guide.

### Web sites

#### **Sheep and Goat Marketing Information**

<http://sheepgoatmarketing.info>

#### **Maryland Small Ruminant Page**

[www.sheepandgoat.com](http://www.sheepandgoat.com)

#### **A PRIMER for Selecting New Enterprises for Your Farm, University of Kentucky Extension**

[www.uky.edu/Ag/AgEcon/pubs/ext\\_aec/ext2000-13.pdf](http://www.uky.edu/Ag/AgEcon/pubs/ext_aec/ext2000-13.pdf)

#### **Starting an Ag-Business? A Pre-Planning Guide**

<http://agviability.cornell.edu/pdf/Pre-businessPlanWorkbook.pdf>

#### **Meat Goat Selection, Carcass Evaluation, and Fabrication Guide**

[www.lsuagcenter.com/en/crops\\_livestock/livestock/sheep\\_goats/Meat+Goat+Selection+Carcass+Evaluation+and+Fabrication.htm](http://www.lsuagcenter.com/en/crops_livestock/livestock/sheep_goats/Meat+Goat+Selection+Carcass+Evaluation+and+Fabrication.htm)

#### **Sheep Budget**

<http://www.sheepandgoat.com/spreadsheets/sheepbudget2004.xls>

#### **Meat Goat Budget**

[www.sheepandgoat.com/spreadsheets/meatgoatbudget2004.xls](http://www.sheepandgoat.com/spreadsheets/meatgoatbudget2004.xls)

#### **Feeder lamb/kid budget**

[www.sheepandgoat.com/spreadsheets/feederbudget2004.xls](http://www.sheepandgoat.com/spreadsheets/feederbudget2004.xls)

# Organic Production



In this section:

- Organic Farm Certification & the National Organic Program
- Organic Certification Process
- Preparing for an Organic Inspection: Steps and Checklists
- Organic Materials Compliance
- Pastures: Going Organic
- Transitioning to Organic Sheep or Goat Dairy Production
- Transitioning to Organic Sheep or Goat Meat Production
- Additional Resources





# Organic Farm Certification & the National Organic Program

MARKETING TECHNICAL NOTE

*Abstract: Farmers planning to market their products as “organic” must become certified. This guide outlines the considerations involved in “going organic” and the basic steps to organic certification. The sole exemption to mandatory certification is also discussed.*

By **George Kuepper**  
NCAT Agriculture Specialist  
October 2002

Related ATTRA Publications:  
• Overview of Organic Crop Production  
• Creating An Organic Production and Handling System Plan

## Introduction

In the earliest years of organic farming in the U.S., most of what was produced was consumed locally. In fact, freshness and direct marketing were often viewed as characteristics of organic production, along with the absence of chemical use. In those years, it was common for the consumer to either have direct contact with the grower, or have confidence in a retailer who purchased directly from the grower. However, as the organic market began to expand in the 1970s, the supply chain lengthened. There was a greater likelihood that organic products would pass through many hands and travel many miles between the farmer and the consumer. Under such circumstances, the end buyer needed some means to confirm that the purchased product was truly organic. Likewise, the farmer needed a way of proving to the consumers that he or she used organic methods. The organic industry addressed these needs through a process called *third-party certification*.



In essence, organic certification is a simple concept. A third party—an *organic certifying agent*—evaluates producers, processors, and handlers to determine whether they conform to an established set of operating guidelines called *organic standards*. Those who conform are *certified* by the agent and allowed to use a logo, product statement, or certificate to document their product as *certified organic*. In other words, the certifier *vouches* for the producer and assures buyers of the organic product's integrity.

By the late 1980s, there were a number of private and state-run certifying bodies operating in the United States. Standards varied among these entities, causing problems in commerce. Certifiers often refused to recognize products certified by another agent as organic, which was a particular problem for organic livestock producers seeking feed, and for processors trying to source ingredients. In addition, a number of well-publicized incidents of

ATTRA is the national sustainable agriculture information service, operated by the National Center for Appropriate Technology through a grant from the Rural Business-Cooperative Service, U.S. Department of Agriculture. These organizations do not recommend or endorse products, companies, or individuals. NCAT has offices in Fayetteville, Arkansas (P.O. Box 3657, Fayetteville, AR 72702), Butte, Montana, and Davis, California.



## Table of Contents

Introduction .....	1
Considering Organic Certification .....	2
Steps To Organic Certification .....	3
Information vs. Consultation .....	3
The \$5,000 Exemption .....	4
Fees for Organic Certification .....	5
Financial Assistance With Certification	
Costs .....	6
Summary .....	6
Notes & References .....	7
Further Resources .....	7

fraud began to undermine the credibility of the organic industry. In an effort to curb these problems, the organic community pursued federal legislation. The result was the Organic Foods Production Act of 1990, which mandated the creation of the National Organic Program (NOP) and the passage of uniform organic standards. These standards are now incorporated in the National Organic Program Regulations, which can be found on the NOP Website at <<http://www.ams.usda.gov/nop/>>. Implementation of the Regulations began on April 21, 2001; all organic certifiers, producers, processors, and handlers must be in full compliance by October 21, 2002.

The principal means by which the NOP is implementing the Regulations is through certifying agencies that it accredits. Through accreditation, the NOP assures that the certifier understands and is using the National Standard; accreditation also confirms that the certifier can conduct the business of certification properly.

Implementation of the National Organic Program Regulations will lead to a number of changes in how producers, handlers, processors and others do their jobs. One thing that will not change greatly, however, is the process of farm certification. The basic steps and considerations remain largely the same as in the past. These steps are outlined in this publication.

## Considering Organic Certification

**Motivations** Organic farming is an environmentally responsible approach to producing high-quality food and fiber. Personal health and environmental concerns have long been motivating factors for those who choose to farm organically. Increasingly, however, economics has become a major factor. Organic farmers typically earn a premium for their production, and though it is not true for all products, many organic commodity crops have lower costs of production than the same conventional crops.

**Commitments** Farming organically involves committing to two principles: *ecological production* and *maintaining organic integrity*. *Ecological production* entails using farming and ranching techniques and materials that conserve and build the soil resource, pollute little, and encourage development of a healthy diverse agroecosystem, which supports natural pest management. These techniques and materials include diverse crop rotations, green-manuring, cover crops, livestock manure, composting, mineral-rich rock powders, etc. *Maintaining organic integrity* consists of actions that prevent contamination of organic production with prohibited materials, and that prevent the accidental mixing (commingling) of organic and conventional products. Farmers accomplish this, first of all, by not using prohibited synthetic fertilizers and pesticides; they also take precautions against pesticide drift from off-farm and other sources of contamination. Many kinds of equipment and storage areas employed in organic production must either be dedicated to organic use or properly cleaned between conventional and organic use. A considerable amount of paperwork and documentation is required to ensure organic integrity; it is one of the necessary “burdens” of being a certified organic farmer or rancher.

Prospective organic producers should understand in advance that prohibited substances (synthetic fertilizers and pesticides, etc.) must not have been used on the land for three full years preceding harvest of the first organic crop. Farms or specific fields that do not yet meet this require-

ment may be considered as in *transition*, though this term does not have legal status at this time.

Organic livestock producers must make a further commitment—to manage and raise their livestock in ways that are not cruel and that take account of the animals’ natural behavior. This includes providing pasture for ruminants and outdoor access for all livestock, and agreeing to restrictions on physical alterations.

## Steps To Organic Certification

The steps to becoming a certified organic producer are very basic. The five that follow are typical, though variations might apply in different circumstances.

**1) Identify a suitable certifier** Organic certification agencies may be operated by a state agriculture department, or they may be private entities, but they must be accredited by the National Organic Program. Certifiers work as an extension of the federal government, licensing producers to use the term “organic” in selling their products. Criteria to use in evaluating a certifier should include:

- Their willingness and ability to answer questions about their certification program.
- Membership in prominent and valuable organizations such as OTA (1) and OMRI (2).
- Their history in certifying your kind of enterprise (Certifiers are in the position of making judgment calls regarding compliance and it helps immensely if they understand the constraints of your enterprise).
- The certifier’s stability as a business (will they be operating again next year?).
- Additional certification services they offer (e.g., Kosher, Free Farmed (3), etc.).
- Market recognition of the certifier logo.
- The needs of buyers (the buyer of an organic commodity may request that a specific certifier be used).
- Additional accreditation beyond the NOP by international certification bodies such as IFOAM (4).
- Costs of certification.

A listing of accredited certifying agents and those making application for accreditation is currently featured on the NOP website.

## Information vs. Consultation

Prior to the implementation of national organic standards, producers commonly sought the advice of certifying agents and organic inspectors on matters ranging from pest control strategies and livestock treatments, to crop rotation schemes and the best sources of purchased inputs. Such advice is now considered a conflict of interest and is not allowed. This new prohibition has created considerable confusion in the organic community.

The key to sorting out this problem is recognizing the basic difference between *information* and *consultation*. Certifiers **MUST** make essential information about their certification process, their fees, and similar matters available to the public. The certifier must tell an applicant how and why he or she is out of compliance. However, the certifier **CAN-NOT** advise the applicant on how to rectify the problem; that would be giving advice or *consultation*. Similarly, the certifier can tell a producer whether or not a particular pest control product is permitted for use. However, the certifier may **NOT** advise about how to use the product or where to buy it.

Certifiers may distribute publicly available information that provides advice and recommendations, such as Extension bulletins or ATTRA publications, or suggest that clients consult these sources; they may also provide producers with lists of private consultants, but may **NOT** recommend a specific one.

**2) Submit an application** After identifying a certifier, the producer should request a copy of the certifier’s organic standards and an application packet, which typically includes an organic farm plan questionnaire (5). An application fee is commonly requested at this stage. The producer should read the standards and ma-

materials lists carefully; the certification agent can answer any questions. The producer must complete the questionnaire, which elicits information about the farm or ranch, including details about soil fertility planning, seeds and seedlings, weed and pest management practices (including the materials one plans to use), and storage and handling routines. Farm maps will be required along with crop and input histories for all fields. Strategies to prevent contamination with prohibited substances and commingling with non-organic products must be outlined. The farm plan questionnaire will also elicit information on the producer's plans to monitor the farm operation to insure compliance. The producer may sign a licensing agreement with the certifier at this time.

**3) Completeness review** The certifier reviews the organic farm plan application to be certain that it is complete and that the operation appears able to comply with NOP organic standards. If additional information is required, the producer will be asked to submit it. (6)

**4) On-farm inspection** If the organic farm plan application is judged to be complete, the certifier assigns an organic inspector (7) to inspect all relevant areas of the farm. The inspector looks for all indications that the producer is operating according to their organic plan and is in compliance with organic standards. He or she inspects the fields, farm implements, and buildings; reviews borders and adjoining land use; and assesses contamination and commingling risks. The inspector reviews all written records documenting management practices, seed sources, inputs used, compost production, conventional production done on the farm, and records of harvest, storage, transportation, and sales. An inspection affidavit is completed during the inspection and signed by the producer and the inspector. The inspector reviews with the producer all identified non-compliance issues at the end of the inspection. Finally, the inspector submits a detailed report to the certifier on all findings. (Note that inspectors only record observations; they do not make decisions about certification.)

**5) Final review** The organic farm plan application and inspection report is reviewed by an individual or certification committee with expertise in organic farming and certification stan-

dards. There can be several outcomes of the review:

- Approval for organic certification
- Request for additional information (6)
- Notification of noncompliance (8)
- Denial of certification

If certification is granted, the producer can begin marketing his or her products as organic. The producer is free to use the seal of the certifier and also the USDA's organic seal (after October 21, 2002).

Notification of noncompliance implies that the applicant will be granted certification if certain things are changed. A producer does have the option of rebutting a charge of noncompliance. He or she also has the option of making application through another certification agent. However, since all certifiers must recognize the same federal standards, any clear violation of standards will need to be rectified. Noncompliance issues often involve inadequate records of such things as manure applications, equipment cleaning on farms where conventional production is also done, and compost preparation.

A denial of certification is typically given when the certifier judges that the producer is clearly unable to comply with federal organic regulations. For example, a farm that has had chemicals used on it and is in its first or second year of transition to organic production cannot be granted certification because the land must be free from prohibited pesticides and fertilizers for a minimum of three years.

At this time, producers may not use "organic," "transitional," "transition to organic," or any similar terminology to describe and market production from fields or farms in *transition*. This issue is under consideration by the National Organic Program and some legal form of transitional status may be recognized in the future.

## *The \$5,000 Exemption*

Producers who market less than \$5,000 worth of organic products annually are not required to become certified, though they have the option of doing so. These operations must still adhere to the federal standards for organic production, product labeling, and handling. Exempted operations face two other constraints. While they

may label their products as organic, they may not use the USDA seal, the seal of a certifier, or otherwise claim that their production is certified. Furthermore, they may not sell their products as ingredients for use in someone else's certified organic product. Retail stores may require exempted producers to sign an affidavit stating that they adhere to federal organic standards.

## Fees for Organic Certification

Certification costs can be expected to rise. Certifiers must now bear the added costs of USDA accreditation. In some instances, certifying bodies have had to undergo serious reorganization to continue providing certification services. These costs will be passed on to producers and handlers in the form of higher fees.

The NOP initially estimated that certification costs would average approximately \$750 per farm. However, fees charged for certification vary among agents. Fees also vary with the size and complexity of the farm operation, the costs of inspection, and other factors. Be certain to get a clear explanation of the fee structure when choosing a certifier.

We obtained a sampling of fee information from five certifiers' websites in late May 2002. The following examples were generated from that sampling to give a notion of the range of fees and the different ways in which they are calculated.



**Example 1** A state-based private certifier that also provides services on the national level.

Within-state fees: The basic producer fees are on a sliding scale based on the gross farm sales. For example, the basic certification fee for a small farm in its first year of certification with gross sales between \$5,000 and \$10,000 is \$434. A larger operation with sales between \$100,000 and \$125,000 would be charged a fee of \$1,112. A farm selling over \$500,000 worth of organic production would be charged \$2,517 plus 0.1% of total sales in excess of \$500,000. Re-certification in subsequent years costs about \$155 less for any operation, regardless of size.

Out-of-state fees: These fees are calculated similarly to the ones charged within state. However, inspection costs are billed separately. In most instances, this will make the total fees charged somewhat higher, because the travel costs of an inspector are usually greater.

Note that for both within-state and out-of-state applicants, additional charges will be billed if follow-up inspections are required. A \$25 fee will be charged if application forms are incomplete and must be re-submitted.

**Example 2** A national private certifier with strong regional focus.

This certifier charges \$25 for the certification packet and \$50 for a first-time application.

The base certification fee is \$150 for farms less than 101 acres; \$175 for farms between 101 and 500 acres; \$225 for farms larger than 500 acres. An additional \$50 is charged if livestock certification is desired. This does not include the costs of inspection, which can vary considerably beginning at a low of approximately \$175.

There is also a 0.5% assessment on gross sales, with an annual cap of \$5,000. Further fees are assessed for certification of on-farm processing.

**Example 3** A state-based private certifier.

Among the smaller certifying bodies at this time, this agent charges an up-front fee of \$350 for initial document review and on-site inspection. Additional inspection and laboratory fees may be charged as required.

**Example 4** A state-based state-run certifier.

This state-run service charges an application fee of \$50 plus a farm inspection fee of \$175. An additional fee of \$100 is charged for inspection of on-farm processing.

In addition, assessment fees are charged on a per-acre basis that varies by crop. Vegetable and herb crops are assessed \$25/acre; fruit and nut crops are assessed \$15/acre; corn is assessed \$2.50/acre; soybeans are assessed \$4.00/acre.

Organic livestock are assessed on a per-head basis for large stock and per-100-head for smaller species. The assessments include \$10/head for cattle, \$1/head for sheep or goats, \$1/100 head for slaughter chickens, and \$10/100 head for laying hens.

**Example 5** A state-based private certifier.

This certifier charges an initial application fee of \$250 plus the costs of inspection (which can vary widely) plus a 25% service charge. Renewal fees for most producers are \$165 (farms with sales less than \$20,000 pay \$110) plus the costs of inspection and the service charge.

In addition to these fees, there is an annual assessment fee of 0.5% on gross organic and transitional product sales for producers whose sales exceed \$20,000. There is a cap of \$20,000 on this assessment.



## Financial Assistance With Certification Costs

The 2002 farm bill has set aside monies for a national organic certification cost-share program to help producers and handlers of organic products obtain certification. The bill allows a maximum federal cost share of 75% of the cost of certification, with a maximum payment of \$500 made to a producer or handler under this provision.

The National Organic Certification Cost Share Program is funded at \$5 million over the 6-year life of the farm bill. This is in addition to \$1 million that had already been made available through the crop insurance bill for the Northeastern states.

It is anticipated that this money will be administered through the National Organic Program. Producers should contact their state organic program offices or the National Organic Program for details on how to apply for this assistance.

## Summary

Federal standards for organic production and marketing have not significantly changed the process of organic certification. Producers will continue to be certified through private and state-run certification agencies.

Certification services vary widely and producers are encouraged to “shop around” before selecting an agent.

Farmers selling less than \$5,000 of organic products annually may opt out of certification. However, they must still comply with the requirements of the National Organic Program Regulations.

Certification costs are expected to rise, though the actual cost and how it is calculated can vary widely. Federal assistance with certification costs will soon be available.

## Notes & References

- 1) OTA (the Organic Trade Association) is a membership-based business association representing the organic industry in Canada, the U. S., and Mexico. It works to promote organic products in the marketplace and to protect the integrity of organic standards. For more information, visit their Website at <<http://www.ota.com/>>.
- 2) OMRI (the Organic Materials Review Institute) evaluates materials for use in most aspects of organic production, handling, and processing. Their published guides of approved inputs are invaluable for informing clients as to what they may and may not use in their operations. For more information on OMRI, visit their Website at <<http://www.omri.org/>>.
- 3) Like Organic, *Free Farmed* is another example of eco-labeling. For more information on the Free Farmed label, visit the Farm Animal Services Website at <<http://www.freefarmed.org/>>.
- 4) IFOAM is the *International Federation of Organic Agriculture Movements*. Their accreditation program for organic certification agencies is operated by the *International Organic Accreditation Service* (IOAS). For more information on IOAS and IFOAM, visit their Website at <<http://www.ifoam.org/>>.
- 5) For more information on the organic farm plan requirement, please request a copy of the ATTRA publication *Creating An Organic Production and Handling System Plan*. This publication includes template forms in common use by certification agencies.
- 6) The kinds of additional information a certification agent might seek are various. In some instances the agent may require that additional testing of soils, water, compost, crops, feeds, or other items be

done. This is typically required if there is reason to expect excessive contamination with prohibited substances. Requests for additional testing might be made at any point in the application process or later.

- 7) Organic inspectors may be employees of the certifier, but many are independent contractors. Many inspectors are members of, and receive training from, the Independent Organic Inspectors Association (IOIA). For more information on IOIA, visit their Website at <<http://www.ioia.net/>>.
- 8) According to John Foster (Quality Assurance International), farmers with minor noncompliances might be granted certification with the understanding that these violations be corrected within a specified time period. Where major noncompliances occur, certification is likely to be withheld until the applicant has made and documented the required changes. (Information provided via personal communication, March 2002.)

## Further Resources

The National Organic Program Website at <<http://www.ams.usda.gov/nop/>> has been cited several times throughout this publication. It is important to note the wealth of additional information that can be found there, including background information on the legislation, an FAQ (Frequently Asked Questions) page, and guidance from the National Organic Standards Board (NOSB)—an advisory body to the NOP that assists in interpreting the Regulations and makes recommendations on materials and practices that can and cannot be used in organic production.

The Organic Trade Association Website features a summary legislation page at <<http://www.ota.com/legislat.htm>>, which gives an excellent overview of the history of federal regulation plus many details contained in the Regulations.

The National Campaign for Sustainable Agriculture closely monitors federal legislation regarding organic farming. Visit their website at <<http://www.sustainableagriculture.net/index.htm>>.

**Acknowledgements:**

Special thanks to Diane Bowen (IFOAM), John Foster (QAI), Harriet Behar (IOIA), and Joyce Ford (Organic Independents) for reviewing and providing comments on this publication.

**By [George Kuepper](#)  
NCAT Agriculture Specialist**

**Edited by Richard Earles  
Formatted by Gail Hardy**

**October 2002**

The electronic version of **Organic Farm Certification & the National Organic Program** is located at:

HTML

<http://www.attra.ncat.org/attra-pub/organcert.html>

PDF

<http://www.attra.ncat.org/attra-pub/PDF/organcert.pdf>

IP222





# Organic Certification Process

A Publication of ATTRA - National Sustainable Agriculture Information Service • 1-800-346-9140 • [www.attra.ncat.org](http://www.attra.ncat.org)

By Ann Baier  
NCAT Agriculture  
Specialist  
© NCAT 2005

This guide is to help organic producers and handlers understand, prepare for, and get the most from the process of organic certification to USDA National Organic Standards (see [www.ams.usda.gov/nop](http://www.ams.usda.gov/nop)). It discusses the purposes and benefits of the inspection for organic certification, provides a general description of the organic certification process, and outlines the role of the organic inspector. A companion ATTRA publication, *Preparing for an Organic Inspection: Steps and Checklists*, is written for those already familiar with the basic certification process, to help them prepare more systematically for an initial or annual inspection. It includes steps for preparing for the organic inspection and checklists of audit trail documents and required records for certification of organic crop and livestock production and handling facilities.

## Contents

Purposes and Benefits of the Organic Inspection .....	2
Steps to Organic Certification.....	3
The Role of the Organic Inspector .....	5
Resources .....	6

**O**rganic certification provides third-party confirmation that a production or handling operation is in compliance with organic standards. Certification enables qualified producers and handlers to market agricultural products under a USDA certified organic seal. In its simplest terms, the organic seal assures the consumer of organic integrity. First, a product is grown in an organic production system that emphasizes plant and animal health, preven-



*The author (right) conducting a field inspection with Delfina Córcoles and her daughter. Photo by Rex Dufour, NCAT.*

tative management of pests, and judicious use of allowed materials. Then, the product is tracked and protected from contamination from the field to final sale, whether it is a raw agricultural commodity or a multi-

ingredient processed product. The label may carry a claim of “100 percent organic,” “Organic” (95% to 100%), or “Made with organic ingredients” (at least 70% organic ingredients).

As an organic inspector, I have heard from both farmers and food processors that an important benefit of organic certification is that it requires and inspires them to keep better records. Records help identify and solve problems more readily. A newly certified organic bakery described how the organic certification process immediately paid off in that business.

- The bakery was having problems with one type of organic bread they were baking. Several batches did not rise properly. The resulting loaves did not have good texture and could not be sold. The bakers turned to the record-keeping system they had recently put into place for their organic certification. This audit trail allowed them to track every ingredient to its source. They looked at their batch sheets and found that they could trace the problem back to a certain

*(continued on page 2)*



(continued from page 1)

lot-number of flour. They contacted the supplier and asked not to be sold that particular lot-number of flour in the future. Their bread quality quickly returned to its usual high standards.

Dairy farmers describe how their record keeping helped them maintain healthier herds and good milk production, after their first year of organic certification.

- Gary and Patricia Belli of Belli Dairy in Ferndale, California, noticed a drop in their herd's milk production. They were keeping track of their purchases of organic feed, with lot numbers and amounts delivered from various sources. By looking at their feed purchase records, they could see the relationship between the decrease in production and the time when they used feed from a certain source. They asked their supplier to avoid a feed lot that appeared to be of poor quality. When they resumed feeding better quality feed from other lots, their milk production problem was solved.
- Robin and Maralyn Renner (brother and sister) manage Diamond R Ranch in Ferndale, California. They run the family dairy and raise organic beef. They described how much healthier their herd was once they began operating as a certified organic operation. Organic certification required that they keep accurate and more detailed records. They said that after working with these records for several months, "We began to recognize patterns." Better records helped them to connect the dots. They saw correlations and discerned causes and consequences. They improved their organic production system by putting what they learned into practice. When I spoke with him recently, Robin reiterated what Maralyn had articulated a year or two earlier: there are practical benefits to keeping the records required for organic certification. Their cows are healthier and they have better farm management. "We're glad we did it," he said. "Every year gets better."

—Ann Baier, organic inspector

## Related ATTRA Publications

Preparing for an Organic Inspection: Steps and Checklists

NCAT's Organic Crop Workbook

NCAT's Organic Livestock Workbook

## Purposes and Benefits of the Organic Inspection

The organic inspection doesn't need to be scary, stressful, or onerous. The inspection process can be useful to producers of crops or livestock, and processors or handlers of agricultural products. The organic inspection is a unique opportunity because it involves the most face-to-face contact between the producer or handler and an inspector who works for the certifier.

Organic certifiers conduct annual inspections of all their clients (certified parties) to verify, through on-site review of actual activities and the corresponding records, that the clients are in compliance with the relevant organic standards. Every USDA-accredited certification agency must make annual inspections. Most inspections are scheduled with the client in advance; however, some inspections are unannounced. This publication will help you incorporate management practices that will keep you prepared for an inspection at any moment.

Benefits of the inspection process for organic certification include the following.

- Building consumer confidence in the meaning of the organic label
- Fulfilling requirements to get or maintain organic certification
- Improving farm record-keeping systems and keeping up-to-date records
- Providing an opportunity to better understand organic standards
- Getting updated information about allowed and prohibited materials
- Learning about public educational opportunities or sources of information and technical assistance available through your certifier, Cooperative Extension, local farm organizations, or industry networks. (Please note that this is not part of the inspection, but an incidental benefit. The role of the inspector is discussed below.)

The steps that help you prepare for your inspection for organic certification will also help you maintain healthy farming systems and viable business practices.

## Steps to Organic Certification

### Step 1: Selection of a certifier

The producer or handler chooses a certifier and requests an application packet. USDA-accredited certification agencies (ACAs or certifiers) are listed on the NOP Web site ([www.ams.usda.gov/nop/Certifying\\_Agents/Accredited.html](http://www.ams.usda.gov/nop/Certifying_Agents/Accredited.html)). All USDA-accredited certifiers—whether private (non-profit or for-profit) or governmental—certify to the same USDA National Organic Standards. Some certifiers, however, are better recognized in the organic industry/marketplace, and some may offer certification to additional standards—such as International Foundation for Organic Agriculture (IFOAM), European Union (EU), Japanese Agricultural Standards (JAS), Conseil des appellations agroalimentaires du Québec (CAAQ), Biodynamic, GAP, Kosher, or Fair Trade—while other certification agencies may provide services such as newsletters, workshops, or educational opportunities. Consider your marketing needs—whether your approach to marketing requires verification of compliance to other standards—as well as your personal interests.

### Step 2: Application and submission of an organic systems plan

The producer or handler submits an application and an Organic System Plan (OSP) to the certification agency, using the certifier's forms and guidelines and attaching any requested documentation, licensing agreements, and fees. The OSP consists of written plans and relevant information concerning all aspects of your operation. Following are some examples of required information.

- **Crop Production:** Land use history documentation, field maps, crop rotation plans, soil improvement and pest management plans, seed sources, material inputs (soil amendments, fertilizers, compost, manure, pest control materials, or any other materials) used and planned for use, measures to maintain organic

integrity (with regard to borders and buffers, application, planting and harvest equipment, post-harvest handling and storage), planting, production, harvest and sales records, monitoring systems, and product labeling.

- **Livestock Production:** Source of animals, feed and feed supplements, description of housing and living conditions, health care practices and materials, management practices (i.e., access to the outdoors and pasture for ruminants), physical alterations, manure management, record-keeping system, and product labeling.
- **Handling Operations:** Sources of ingredients and processing aids, materials and standard operating procedures for cleaning, sanitation, and pest control, measures to protect organic integrity (prevention of commingling and contamination), packaging, record-keeping system, product formulations, and product labeling.



*An Organic System Plan should include information about management practices such as animals' access to pasture and outdoors. The pastured layer hens at left belong to Paul and Leti Hain of Tres Pinos, California. Photo by Ann Baier.*

### Step 3: Application and Organic System Plan Review by the Certifier

The certifier reviews the Organic System Plan (OSP) and accompanying documentation for completeness and assesses the applicant's capacity to operate an NOP-compliant operation. The certifier determines that the operation can meet the requirements for certification as outlined in the OSP. The certifier will then assign a qualified organic inspector to do an on-site inspection.

Organic inspectors assess the adequacy of procedures to prevent contamination.  
Photo by Ann Baier.



#### Step 4: Organic inspection

Organic inspections come prior to initial certification, then annually thereafter. The inspection must occur when a person knowledgeable about the operation is present, and should occur where and when the crops, livestock, and/or processing or other handling can be observed.

The Inspection Preparation Checklists in the ATTRA publication *Preparing for an Organic Inspection: Steps and Checklists* provide a detailed description of the documentation required for the three major types of operations: crops, livestock, and handling. In all three types of operations, the organic inspector conducts an on-site inspection and review of record keeping to verify that the OSP accurately reflects your operation and is in compliance with NOP standards. Records to be verified include input materials, production, harvest and sales records, as well as appropriate product packaging and labeling. The inspector assesses the risk of contamination from prohibited materials, and may take soil, tissue, or product samples as needed.

- The farm (crop) inspector inspects fields, soil conditions, crop health, approaches to management of weeds and other crop

pests, water systems (for irrigation and post-harvest handling), storage areas, and equipment.

- The livestock inspector inspects feed production and purchase records, feed rations, animal living conditions, preventative health management practices (vaccinations and other medications currently being used or planned for future use), and health records. The inspector observes and assesses the animals' condition.
- The handler or processing inspector inspects the facility and evaluates the receiving, processing, and storage areas used for organic ingredients and finished products. Critical control points are an essential part of any handling operation and its inspection. The inspector analyzes potential hazards and assesses organic control points—the adequacy of procedures to prevent contamination (from sanitation supplies, pest management materials, or non-organic processing aids), and to prevent commingling with non-organic ingredients.

At the end of the inspection, the inspector conducts an exit interview with the inspected party to confirm the accuracy and completeness of the inspector's observations. The inspector will review any requests for additional information and any issues of potential non-compliance with respect to the National Organic Standards. The inspector provides the inspected party with a written copy of the exit interview before leaving the inspection. The inspector then provides a report to the certifier. The inspector reports his or her observations only and does not make the certification decision.

#### Step 5: Review of the inspection report by the certifier

The certifier will review the report and determine whether the operation is eligible for organic certification. The final decision is then communicated in writing to the client seeking certification, along with any requirements for initial or continuing certification. The certifier may request

further information or remediation, or issue a notice of noncompliance, if the operation is not in full compliance with all pertinent organic standards. Significant noncompliances may result in denial or revocation of certification and/or require correction prior to organic certification or renewal. Minor non-compliance issues are those that do not threaten the integrity of the organic products. (For example, procedures are properly carried out but inadequately documented.) The notice will cite the issues of concern and specify the time by which the operation must remedy the noncompliance and provide documentation of the remediation to the certifier.

## Step 6: Organic certification

A certificate of organic certification is issued if the operation is determined to be compliant under the NOP (and any other applicable) standards. Upon issuance of the organic certificate, the operation may begin selling its products as organic. Product labels must identify the certifier (“Certified organic by...”) beneath the name and identifying information of the producer or handling company. Use of the USDA and/or the certifier’s seal is optional. The certified party should review the details of labeling in NOP section 205.300-311, and ask the certifier to review any labels prior to printing. All certified operations must be inspected annually.

## The Role of the Organic Inspector

The “inspector” is not the same as the “certifier.” It is important for the producer or handler to have clear expectations about the role of the inspector—what services he or she can and cannot provide. As noted in Step 4: Organic Inspection, the primary role of the inspector is to gather on-site information and provide an accurate report to the certifier. The inspector verifies a) whether observations of an operation’s daily practices are consistent with the client’s Organic System Plan (previously submitted to and

approved by the certifier), b) whether the practices and inputs are in compliance with the USDA National Organic Standard, and c) whether those practices and inputs are adequately documented. The certifier then makes the certification decision based on information provided in the OSP, the inspection report, and associated documents.

The inspector can do the following:

- provide information about the certification process
- answer general questions about organic standards and requirements
- explain the range of practices and/or record keeping that the certifier considers sufficient to show compliance
- make referrals to public sources of information, such as Cooperative Extension services, USDA agencies, farm organizations, trade associations, and ATTRA’s toll-free line and publications

The inspector cannot serve as your advisor or consultant. The inspector may not recommend specific products, practices, animal or plant varieties, or give advice for overcoming identified barriers to certification. The inspector must not hold a commercial interest in the business being inspected, provide paid consulting services, accept gifts, favors, or payments other than the prescribed inspection fee. Finally, the inspector does not make the certification decision. Any of the above constitutes a conflict of interest that is strictly prohibited by law, as described in NOP Section 205.501.

The certified entity can be assured that the inspector has signed both a conflict of interest and a confidentiality agreement with the certifier to protect all proprietary information of the inspected operation.

Even when you take into consideration the limitations of the inspector (as described



*The organic inspector can refer clients to sources of information about organic compliance.*  
Photo by Ann Baier.

above), the inspection can still be a useful opportunity to expand your knowledge of organic requirements, the processes necessary to meet those requirements, and associated information. As you prepare for your inspection, you might find it helpful to make notes of any

questions you have, in particular about the certification process and where to go for assistance in answering further questions. To avoid potential conflicts of interest, please be aware of the limitations on the role of your inspector.

## Resources

The National Organic Program (NOP)  
[www.ams.usda.gov/nop](http://www.ams.usda.gov/nop)

Organic Materials Review Institute  
[www.OMRI.org](http://www.OMRI.org)

International Federation of Organic  
Agriculture Movements  
[www.ifoam.org](http://www.ifoam.org)

Biodynamic Farming and Gardening Association  
[www.biodynamic.org.nz/demeter.html](http://www.biodynamic.org.nz/demeter.html)

International Organic Inspection Manual IFOAM and IOIA, December 2000. Order from:

Independent Organic Inspector's Association  
(IOIA)  
P.O. Box 6  
Broadus, MT 59317-0006  
406-436-2131 telephone/FAX  
[ioia@ioia.net](mailto:ioia@ioia.net)  
[www.ioia.net](http://www.ioia.net)

### Acknowledgements

Thanks to Brian Magaro and Lois Christie, organic inspectors who provided their pre-inspection letters as resources for developing this publication.

Appreciation to the following reviewers:

Lois Christie, Fiesta Farms

Doug Crabtree, Montana Department of Agriculture, Organic Certifier

George Kuepper, Program Specialist, NCAT

Nancy Matheson, Program Specialist, NCAT

Jim Riddle, Organic Independents

Jeff Cunningham, Organic Inspector



**Organic Certification Process**

By Ann Baier  
NCAT Agriculture Specialist  
©NCAT 2005

Paul Williams, Editor  
Robyn Metzger, Production

This publication is available on the Web at:  
[www.attra.ncat.org/attra-pub/organic\\_certification.html](http://www.attra.ncat.org/attra-pub/organic_certification.html)  
or  
[www.attra.ncat.org/attra-pub/PDF/organic\\_certification.pdf](http://www.attra.ncat.org/attra-pub/PDF/organic_certification.pdf)

IP 262  
Slot 266  
Version 112905



# PREPARING FOR AN ORGANIC INSPECTION: STEPS AND CHECKLISTS

MARKETING, BUSINESS, AND RISK MANAGEMENT

***Abstract:** This guide is to help organic producers and handlers understand, prepare for, and get the most from their annual inspections for certification of compliance with USDA National Organic Standards ([www.ams.usda.gov/nop](http://www.ams.usda.gov/nop)).*

By Ann Baier  
NCAT Agriculture Specialist  
January 2005  
©NCAT 2005

## Table of Contents

Introduction . . . . .	1
Inspection Preparation . . . . .	2
Summary . . . . .	8
References . . . . .	8
Acknowledgements . . . . .	8

## Introduction

This publication provides checklists of the documentation needed for organic certification. These will help organic producers or handlers organize their paperwork for an organic inspection. It includes steps for preparing for the organic inspection and checklists of audit-trail documents and required records for certification of organic crop and livestock production and organic handling facilities.



*On a Salinas Valley, California, organic farm, horticulturist Eric Brennan harvests a bundle of a late-summer rye cover crop. Photo by Scott Bauer ©2005 ARS*

## Inspection Preparation

Organic certification is about verifying that you are managing an organic system to grow crops, raise livestock, and/or process food and fiber according to the National Organic Standards. An important part of being prepared is being able to track your product from the field or point of purchase to the consumer, ensuring that the product has been kept separate from non-organic products and has not been contaminated in any way by materials prohibited for use in organic production. Producers and handlers will find it useful to follow the following four steps to prepare for their annual inspection.



Photo by Scott Bauer ©2005 ARS

### **Review the sections of the National Organic Standards that are relevant to your operation**

To their detriment, people often do not read the National Organic Standards. They may seem long and overwhelming, but if you are familiar with the key standards relevant to your opera-

tion, your inspection will make a lot more sense. Certifiers provide a copy of the standards with their application package, and the standards are also available on the NOP Web site: [www.ams.usda.gov/nop/NOP/standards/FullText.pdf](http://www.ams.usda.gov/nop/NOP/standards/FullText.pdf)

These Standards were written to address most agricultural production and processing activities. Not all portions will be applicable to every operation. As you review them, look for and focus on the parts that *do* apply to your operation. The definitions in Part 205.2 will help you understand key terms.

- *Crop Producers:* Production Requirements in Sections 205.200 through 205.207; Materials on the National List in Sections 205.600 through 205.603; Recordkeeping in Section 205.103; and Labeling in Sections 205.300 through 205.311.
- *Livestock Producers:* Production Requirements in Sections 205.236 through 205.239; Materials on the National List in Sections 205.600 and 205.603-604; Recordkeeping in Section 205.103; and Labeling in Sections 205.300 through 205.311. (Livestock producers who raise their own feed must also comply with the requirements for crop production.)
- *Handlers:* Handling Requirements in Sections 205.270 through 205.272; Materials on the National List in Sections 205.600 and 205.605-606; Recordkeeping in Section 205.103; and Labeling in Sections 205.300 through 205.311.

### **Review your Organic Systems Plan (OSP)**

The OSP must be updated and submitted to your certifier whenever a significant change is made to your operation. Each certifier has particular forms and procedures for keeping OSPs current. In preparation for your annual inspection, verify that your OSP is current and complete, with all pertinent attachments. If you have not already submitted them to your certifier, be prepared to provide updates at the time of your inspection. Keep copies for your files. You must have a complete, current OSP on file at all times. Be prepared to show records of how you implement each part of your OSP.

## **Review any communications from your certifier that you have received in the past year**

Each year you will receive a letter that addresses your certification status. (Certifiers have different names for this letter: certification determination letter, notice of noncompliance, certification status report, remediation letter, conditions letter, evaluator's circle, etc.) Does this letter describe any areas in which your operation was found to be other than fully compliant by the previous inspection and review process? Have you resolved the issues that were raised after your previous inspection? Have you responded in writing to any requests made by your certi-



*Photo by Scott Bauer ©2005ARS*

fier? Can you provide documentation to show how you have addressed these issues? The annual inspection must verify that all previously cited noncompliances have been corrected. Be prepared to demonstrate and provide documentation that you have taken corrective measures and that your operation is fully compliant with the standards cited in the notice of noncompliance.

Communications from your certifier may also include general memos to all certified clients explaining updates to the lists of allowed or prohibited brand-name materials, changes or updates to manuals, renewal procedures, fees, inspection protocol, and interpretation or clarification of standards. The inspection and certification process will go more smoothly if you know what to expect and keep yourself educated about any changes that occur.

## **Gather your records using the following organic inspection checklists**

### **Organic Inspection Checklists**

The National Organic Standards specify that records must “fully disclose all activities and transactions in sufficient detail as to be readily understood and audited” (NOP Section 205.103(b)(2)). Are you prepared to explain your recordkeeping system? Is anything missing or incomplete? You can make your inspection easier and more efficient by doing a self-audit beforehand, using the following checklists. Please note that these lists are comprehensive, and some items may not apply to your operation.

#### **Crop production documentation checklist**

- ◆ **List of crops** being grown, field locations (maps), acreages, and estimated yields

**Field history** or land use documentation, if any new land is added this year

**Field activity logs** for all practices performed (cultivation, weed control, use of manure or fertilizers, spraying, pruning, beneficials released, etc.)

- ◆ **Input purchase/source records** of all inputs used for crop nutrients, pest, disease, or weed control
  - ◆ Receipts
  - ◆ Invoices
  - ◆ Delivery tags
  - ◆ Receipts or logs recording the pick-up or delivery of free materials
  - ◆ Labels and/or documentation demonstrating that each material is allowed for use in organic production.

- A generic material (e.g., mined limestone) must be on the National List as allowed.
- A brand name product must either
  - have a label that discloses all ingredients, including inert ingredients, so that they all may be verified as allowed; or
  - be listed as an allowed brand-name material on a list approved by the certifier (e.g., the Organic Materials Review Institute (OMRI) Brand Names List, the Washington State Department of Agriculture (WSDA) list, or others). Find out from your certifiers whether they maintain their own list of approved materials, perform their own brand-name material reviews, or whether they honor other lists, and if so, which.
- ♦ Note that manure must either be composted according to NOP standards or its date of incorporation documented to comply with the required number of days before harvest of a crop intended for human consumption.
- ♦ **Input application records** (material, source / brand name / manufacturer, regulatory status, field location, date, and rate or quantity used)
  - ♦ Seeds (crop and cover crop), planting stock, annual seedlings, and transplants
  - ♦ Seed coatings and inoculants
  - ♦ Greenhouse materials (e.g., potting soils or soil mix ingredients)
  - ♦ Crop nutrients and soil amendments
  - ♦ Pest management materials
  - ♦ Beneficial insect releases
  - ♦ Natural, organic, or plastic mulches
  - ♦ Any other materials applied
- ♦ **Seed, planting stock, and transplant records**
  - ♦ Documentation that seeds and annual transplants are certified organic, *or*
  - ♦ For any non-organic seed or planting stock used, documentation of:
    - Your unsuccessful search for commercially available organic seed or planting stock (most certifiers require documentation of non-availability from three sources), *and*
    - Verification that the seed or stock used is not genetically modified or treated with prohibited materials
- ♦ **Audit trail documents** that track products from the field of origin to final use or sale. A random audit is part of inspection procedures. It may require the following.
  - ♦ Field, planting and production records
  - ♦ Harvest and yield records
  - ♦ Post-harvest handling records
  - ♦ Storage records
  - ♦ Transport records
  - ♦ Sales records
- ♦ **Soil management activities**, including crop rotation and erosion prevention activities
- ♦ **Pest management activities** for control of crop pests (insects/mites/invertebrates/vertebrates), diseases, and weeds, including:
  - ♦ Preventative practices
  - ♦ Materials used, if any
  - ♦ Pesticide use reports, as required by law, if applicable (*Some states require reporting of all applications of EPA-registered materials to commercial crops to the County Agricultural Commissioner, Department of Weights and Measures.*)
- ♦ **Organic Integrity: Documentation** of measures to avoid contamination and commingling, as applicable to your operation
  - ♦ Information about neighboring land use
  - ♦ Prevention of contamination from borders
  - ♦ Production, harvest, and sales records for buffer crops, transitional or conventional crops

- ♦ Material storage: adequate separation of allowed materials from any non-allowed products
  - ♦ Irrigation water and system for contamination prevention (i.e., diagram of valves, backflow prevention, and/or documentation of purge or flushing procedures to prevent contamination from shared water systems where fertilizers or other prohibited materials are used)
  - ♦ Clean-out or purge logs for equipment used for both organic and conventional operations
  - ♦ Documentation of procedures to verify the absence of sanitizer residues, if sanitizers are used
- ♦ **Certification documentation** of any organic product purchased for resale
  - ♦ **Labels and labeling**
    - ♦ Printed packaging, bags, boxes, ties, bands, and stickers
    - ♦ Lot numbering of retail and bulk products, if applicable

### **Livestock Production Documentation Checklist**

- ♦ **Animal lists**, including livestock or poultry descriptions and/or numbers and identification methods
- ♦ **Source of poultry and/or livestock**, including breeding, birth, hatching, and/or purchase records
- ♦ **Feed harvest and storage records**
- ♦ **Feed rations** for each type of animal during each stage of growth and development
- ♦ **Feed and feed supplement purchase records** and documentation that they are certified organic or allowed
- ♦ **Drinking water**, including source, additives, potential sources of contamination, and results of any water analysis
- ♦ **Audit trail** documents that track animals or animal products (harvest or slaughter,

processing/post-harvest handling, transport, and sales records)

- ♦ **Housing and living conditions**, including grazing management and outdoor access records
- ♦ **Animal medications**, including a list of all products used or that may be used (everything in your medicine cabinet or refrigerator, with product names, ingredients, manufacturers, and regulatory status)
- ♦ **Health management records**, including vaccinations and all other materials, veterinarian bills, purchase invoices, records of medication used, reason for use, and animal identification
- ♦ **Marking and segregating methods** for animals treated with prohibited materials
- ♦ **Soil management**, erosion control, crop nutrition, and pasture management
- ♦ **Manure management** (must not contribute to contamination of crops, soil, or water)
- ♦ **Pest management**, including parasite management
- ♦ **Off-site processing records**, including slaughter, cold storage, and meat packing (These activities must take place at facilities that are already certified organic, or they must be inspected as part of your operation.)
- ♦ **Product or animal sales records**
- ♦ **Labels**, if applicable

### **Handling Production Documentation Checklist**

- ♦ **Product identification and composition** for all organic products produced (This must include current formulations, recipes, or batch sheets that support the percentage of organic ingredients in your product label claim – “100% Organic,” “Organic,” or “Made with organic....”)

- ◆ **Facility map(s)** showing the facility perimeter and buildings, all equipment, and areas used for receiving, raw material storage, processing, packaging, finished product storage, and shipping
- ◆ **Production flow chart(s)** that includes equipment used in each step or stage of the process and shows the flow of products through the facility from receiving of raw ingredients to shipping of the final product
- ◆ **Documentation of sources of ingredients and processing aids**
  - ◆ Organic ingredients and processing aids: You must have on file a copy of the organic certificate from the supplier of any organic ingredient or processing aid, showing that it is certified to NOP standards, along with the level of certification that supports the label claim you intend to make. For example, if your label makes the claim of 100% organic, all ingredients and processing aids must be documented to be certified as 100% organic.
  - ◆ Non-organic agricultural ingredients and processing aids: You must provide documentation affirming that each specific ingredient a) is not commercially available as organic, b) does not contain prohibited inputs and has not been produced using prohibited methods (genetic engineering), c) has not been treated with ionizing radiation, and d) is not produced from a crop grown using sewage sludge.
  - ◆ Non-agricultural ingredients: All non-agricultural ingredients must be listed on and consistent with the annotations of the National List (NOP Sections 205.605 through 205.606).
- ◆ **Pest management**  
Documentation for preventative practices, procedures, maps, logs, service reports, and incident records must be provided. Whether your pest management is done in-house or by a contracted pest control company, you must document what materials are used, if any, including maintaining product labels or MSDS pages

on file. If prohibited materials (substances not on the National List) are used inside your facility, be prepared to show documentation of how organic products and materials are protected from contamination during pest control applications.

- ◆ **Sanitation**

You will need documentation of standard operating procedures, equipment cleaning, equipment purge logs, and residue testing. Residue test procedures must be appropriate for the sanitation materials used. For example, if chlorine is used as a sanitizer, a chlorine test strip with sensitivity in the low (0-10 ppm) range must be used to show that the level of chlorine remaining is below 4 ppm, the level allowed in NOP section 205.606. Materials that are not listed as allowed sanitizers are now allowed, but if they are used, they must be completely removed before running organic products. For example, if acid or alkaline sanitizers are used, a pH test with a neutral result (or one that matches the plain water used in the facility) indicates that the sanitizer material has been washed off. Quaternary ammonia is not listed and not allowed, and therefore must be completely removed, such that there are no detectable residues, and residues do not contaminate organic products. Records must be maintained for each area or production line where organic processing occurs, showing how organic products and packaging materials are protected from contamination by conventional product residues and/or sanitation chemicals on food contact surfaces.

- ◆ **Water**

You will need documentation of source, use, additives, and any applicable tests results.

- ◆ **Culinary steam**

Provide a list of all boiler additives, MSDS pages for all additives, results from any carryover tests, and explain how the organic product is protected from boiler additive contamination.

- ◆ **Organic integrity** (organic critical control points)  
You will need documentation of systems and procedures to prevent commingling and/or contamination of organic ingredients and products throughout all steps of processing.
- ◆ **Audit trail/audit control documents**  
The organic recordkeeping system must accomplish two objectives: 1) trace products as certified organic from the raw ingredients to final sale (for verification of sources and/or sample recall from final destination); and 2) verify the input-output balance of organic ingredients and organic products, including current inventory. Be prepared to supply samples of paperwork during the inspection to track ingredients to finished products for any item and for any time that may be randomly selected for an input/output audit.
  - ◆ The audit documents for purchase, receiving, storage, production, packaging, handling, transport, and sales may include, but are not limited to, invoices, weight slips, purchase orders for incoming materials, invoices for finished product, descriptions of product tracking or coding, logs for receiving, processing, storage and inventory systems, transport cleaning documentation for incoming and/or outbound materials, and product labels.
  - ◆ The input/output balance audit documents may include, but are not limited to, inventory, purchase, production, and storage records – including typical conversion figures for shrinkage, reconditioning, donated products, samples, dumping, shipping, and sales records.
- ◆ **Labels and labeling**  
You will need finished product labels (retail and wholesale labels on printed packaging, boxes, etc.), with the proper placement of the phrase identifying the certifier, relative size of USDA and certifier logos, lot number, and market destination, as applicable.

- ◆ **Off-site storage/contracted facilities**  
If your operation uses off-site, contracted warehousing or outside contractors for handling of ingredients or finished products, you will need to provide information about how the off-site facility is used. Depending on what they do, such facilities may need to be certified to operate under the certificate of the entity for whom they provide custom services, or provide an affidavit that they meet the criteria of an excluded operation (see NOP Section 205.101 for definitions and requirements).

### General Checklist for all Organic Operations

- ◆ Current state organic registration (Department of Food and Agriculture or Department of Health Services), if applicable
- ◆ Complaint Log (procedure for response to any complaints related to organic integrity). This is an ISO 65 requirement if any products are to be exported.
- ◆ Documentation and/or demonstration of the correction of previously cited issues of noncompliance

### Checklist for Planning for Inspection Day

- ◆ Ensure that you can devote the time and attention needed to complete the inspection.
- ◆ Make prior arrangements for someone else to handle work-related tasks and/or family commitments.
- ◆ Have all your records ready and accessible.
- ◆ Provide a space where you and the inspector can comfortably review records. While a tailgate may suffice for some operations on a sunny day, a clear table and place to sit out of the wind and weather are preferable. Some inspectors require space for a laptop computer.
- ◆ Be prepared to provide easy and prompt access to all fields, buildings, and storage areas, both on- and off-farm. This may in-

clude having keys to gates and sheds and having other management personnel available. If you have multiple fields or sites, be sure to advise your inspector, so that sufficient time is allotted for your inspection.

- ◆ Have enough gas in the pickup (or other appropriate vehicle) to reach the more remote parts of the farm or facilities.

## Summary

The on-site inspection is an important part of the organic certification process. It can be useful to you as an organic producer or handler in at least two significant ways: a) by providing you with a certificate of organic certification to the USDA National Organic Standards and other applicable standards and b) by providing the impetus and inspiration to develop and implement organic systems for production and handling and their corresponding record-keeping systems. This publication is intended to show how organic production or handling systems and sound record-keeping systems reinforce each other to support continuous learning about organic systems design and good business management.

## References

Biodynamic Farming and Gardening Association  
[www.biodynamic.org.nz/demeter.html](http://www.biodynamic.org.nz/demeter.html)

International Federation of Organic Agriculture Movements  
[www.ifoam.org/standard/](http://www.ifoam.org/standard/)

International Organic Inspection Manual  
IFOAM and IOIA, December 2000. Order from:  
Independent Organic Inspector's Association (IOIA)  
P.O. Box 6  
Broadus, MT 59317-0006

406-436-2131 (telephone/FAX)  
[ioia@ioia.net](mailto:ioia@ioia.net)  
[www.ioia.net](http://www.ioia.net)

The National Organic Program (NOP)  
[www.ams.usda.gov/nop](http://www.ams.usda.gov/nop)

Organic Materials Review Institute  
[www.OMRI.org](http://www.OMRI.org)

## Acknowledgements

Thanks to Brian Magaro and Lois Christie, organic inspectors who provided their pre-inspection letters as resources for developing this publication.

Appreciation to the following reviewers:  
Luis Brenes, Organic Inspector and Trainer  
Lois Christie, Fiesta Farms  
Doug Crabtree, Montana Department of Agriculture, Organic Certifier  
Jeff Cunningham, Organic Inspector  
George Kuepper, Program Specialist, NCAT  
Nancy Matheson, Program Specialist, NCAT  
Jim Riddle, Organic Independents

### **Preparing for an Organic Inspection: Steps and Checklists**

**By Ann Baier**  
**NCAT Agriculture Specialist**

**January 2005**  
**©NCAT 2005**

**IP261**

**Slot# 265**

**Edited by Paul Williams**

**Formatted by Cynthia Arnold**

**Version 030105**

The electronic version of *Preparing for an Organic Inspection: Steps and Checklists* is located at:

HTML  
[http://www.attra.ncat.org/attra-pub/organic\\_inspection.html](http://www.attra.ncat.org/attra-pub/organic_inspection.html)

PDF  
[http://www.attra.ncat.org/attra-pub/PDF/organic\\_inspection.pdf](http://www.attra.ncat.org/attra-pub/PDF/organic_inspection.pdf)





# Organic Materials Compliance

## Materials for Organic Production, Handling, and Processing: Planning for Compliance with USDA's National Organic Program

A Publication of ATTRA - National Sustainable Agriculture Information Service • 1-800-346-9140 • [www.attra.ncat.org](http://www.attra.ncat.org)

By Ann Baier and  
Lance Genger

NCAT Agriculture  
Specialists

© 2008 NCAT

### Contents

Three Steps to Ensure  
Organic-Compliant Use  
of Materials for Organic  
Production and  
Handling

Step One.....2  
*Become familiar with  
National Organic  
Program regulations  
about materials for your  
type of operation.*

Step Two .....4  
*List every material you  
use or plan to use in the  
Organic System Plan with  
supporting  
documentation as  
required, and obtain  
approval from your  
organic certifier of this  
Plan before you use any  
material.*

Step Three .....7  
*Document every input  
material purchase and  
use, and keep those  
records for a minimum of  
five years.*

The USDA's National Organic Program regulates the use of substances and materials for farming, handling, and processing. This publication discusses three basic steps to ensure that materials use is compliant with organic standards and certification. First, understand the regulations relevant to your operation. Next, create an Organic System Plan with your certifier. Finally, keep records of your purchase and use of all materials. Following these steps will help ensure compliant use of materials, and avoid any use of a prohibited material or incorrect use of a restricted material—which could necessitate an additional three-year transition process.

Materials that are used to produce and handle organic crops under the USDA's National Organic Program (NOP) must be selected for compliance and used in the context of organic principles for farming and handling practices.

The NOP regulations describe organic farming systems as those that maximize cycling of nutrients through crop rotations, cover crops, and green manures. The systems are designed to conserve soil, improve soil health, enhance biodiversity, and prevent pest problems. Organic farming is not simply the substitution of natural materials for synthetic ones. It is a whole-systems approach.

Organic producers and handlers first must be able to describe and document how their operations apply organic principles and implement proactive strategies to prevent problems. Then they verify and document compliant use of materials employed for specific purposes within those operations.

Whether a material is allowed or not depends on the context. Some types of materials are integral to maintaining an organic system. Others may be used only when cultural, biological, mechanical, or physical methods are insufficient. This paper discusses some basic steps to ensure that the materials proposed for use are compliant with organic standards and certification to NOP standards.



Photo: Rex Dufour

*Beneficial insect hedgerow along organic field edge.*

Certified organic producers and handlers must use only materials that are approved for use according to the standards to which they will be certified. Therefore, the first step is to understand the standards relevant to one's operation. **Prior** to using any material, certified operations must include in their Organic System Plan (OSP) a list of all materials they use or plan to use. They must have the OSP approved by their organic certifier.

Finally, organic producers and handlers must keep records of the purchase and application of all materials. This three-step process will enable the producer or handler and their certifier to evaluate materials for their intended specific use, and to ensure their compliance with relevant standards.

Non-compliance can jeopardize certification status. Use of a prohibited material or violation of a restriction (annotation) on the use of a material can set an operation back three years to begin the transition process again.



# Three Steps to Ensure Organic-Compliant Use

To help ensure compliant use and documentation of materials for organic production and handling, follow these essential steps:

## STEP ONE — Become familiar with NOP regulations about materials for your type of operation.

**R**ead the Rule: In general, Natural Materials are allowed (unless they are prohibited); Synthetic Materials are prohibited (unless they are allowed). Then, pay attention to annotations.

The regulatory texts of the National Organic Program standards are available on USDA's National Organic Program website: [www.ams.usda.gov/nop/indexIE.htm](http://www.ams.usda.gov/nop/indexIE.htm)

To view the production and handling standards, go to the above page. Under General Information, click on Regulations to bring up a new window. Then under Regulatory Text, click on Electronic Code of Federal Regulations. It is important to review the full set of regulations in order to find and understand the key parts that apply to your operation.

### What do the NOP Standards say about Input Materials? Or: Why isn't the answer simple?

Several sections of the National Organic Program regulations (the "Rule") describe *which* materials are allowed *for what purposes* and *under what circumstances*. Sections of the Rule that address materials allowed for specific purposes can be found in the paragraphs that discuss crop production, livestock production, and handling (processing). Several materials are listed with annotations that limit or restrict products to specific uses within these broader purposes. For example, hydrated lime may be used as an ingredient in Bordeaux mixture for disease management on fruit trees—when other preventative practices are not enough and its use is consistent with Rule section 205.206(e). But hydrated lime cannot be used as a soil amendment.

### Where in the Standards can I find the rules about materials?

Sections 205.105 and 205.600-606, the National List of Allowed and Prohibited Substances, are the main places to find information about allowed and prohibited materials. However, there are also specific regulations within the standards for certain materials. For example, application of raw manure is addressed in section 205.203(c)(1); production of manure-based compost in 205.203(c)(2), and other materials used for soil fertility in 205.203(d).

### **The General Rule for Organic Crop and Livestock Production: Natural materials are allowed. Synthetic materials are prohibited.**

For organic crop and livestock production, the Rule clearly states that natural materials are allowed unless specifically prohibited, and that synthetic materials are prohibited unless they are specifically allowed.

### **The Exceptions: Allowed Synthetic Materials**

The following sections list the exceptions to this general rule. Section 205.601 lists synthetic substances allowed for use in organic crop production. This list includes substances such as fish extracts for fertilizer, chlorine for washing vegetables (discharge or effluent water concentration below drinking



*Organic calves on pasture on LaMacchia Ranch, Gonzales, California, owned and managed by Frank and Irene LaMacchia. Organic livestock operations use compliant practices and materials to manage their fields and pastures as well as their animals' health. Photo: Ann Baier*

water standards), and copper sulfate for crop disease control. Section 205.603 lists synthetic substances allowed for use in livestock production, and includes materials such as iodine, vaccines, vitamins, and minerals.

### ***The Exceptions:*** **Prohibited Natural Materials**

Sections 205.602 and 205.604 list nonsynthetic (natural) materials prohibited for crop and livestock production, respectively.

While each of these lists is fairly short, it is important to become familiar with the prohibited materials as well as the allowed materials.

Just as some of the synthetic materials are restricted by annotations, some of the prohibited natural substances have exceptions that permit their limited use.

### **Materials lists for organic processing and handling are organized differently.**

For organic processing and handling, the lists of materials that are allowed for use are in separate sections of the National List (205.605 and 205.606). These lists are organized differently than crop and livestock lists, in that they name specific allowed and restricted materials. Section 205.605 lists non-agricultural substances allowed for use in or on processed products labeled as “organic” or “made with organic ingredients” (product claims). The National List section 205.606 lists non-organically produced agricultural products that are allowed as ingredients in products labeled as “organic” or “made with organic ingredients.”

You can list a material or product planned for use in your Organic System Plan (OSP) with relative confidence by verifying that it is allowed.

#### **Related ATTRA Publications**

National Organic Program Compliance Checklist for Producers

National Organic Program Compliance Checklist for Handlers

Organic Farm Certification & the National Organic Program

Organic Crop Production Overview

NCAT's Organic Crops Workbook – A Guide to Sustainable and Allowed Practices

NCAT's Organic Livestock Workbook – A Guide to Sustainable and Allowed Practices

Organic System Plan (OSP) Templates for Certifiers

Organic Certification Process

Preparing for an Organic Inspection: Steps and Checklists

And many more listed at [www.attra.ncat.org/organic.html](http://www.attra.ncat.org/organic.html)



*In the hedgerow shown on page one, a Monarch butterfly larva and aphids feed on narrowleaf milkweed, as the chrysalis sparkles like a jewel. This native perennial hedgerow was planted at Fong Farms in Woodland, California, to attract beneficial organisms. The aphids, larva and chrysalis represent diversity on the farm. They also serve as non-pest alternate hosts for parasites and predators that are feeding on farm pests. The field in the background is planted with organic alfalfa. Photo: Rex Dufour.*

**STEP TWO —**  
**List every material you use or plan to use  
in your Organic System Plan (OSP)  
with supporting documentation as required,  
and obtain approval from your organic certifier of  
this Plan before you use any material.**

**C**reate an  
Organic  
System  
Plan with a list of  
compliant materials  
that you plan to use.  
Your certifier must  
approve this Plan.

**Verify the precise identity of any material you plan to use, including the product brand name, formulation, and manufacturer/source of every material in your Organic System Plan.**

Avoid the common mistake of confusing the manufacturer of a product (who made it) with the distributor or supplier (who sold it to you). It is the identity of the manufacturer that is important in determining whether a product is allowed. Whether you bought it from the local hardware store or the farm supply is unimportant.

**Find out if your organic certifier has a list of approved brand name materials, or whether they honor other lists.**

Many certifiers recognize the Organic Material Review Institute (OMRI) and/or the Washington State Department of Agriculture (WSDA) products lists (see direct links and explanation of these lists below). In this case, certified clients can refer to these current lists of acceptable brand name materials. Some certifiers maintain their own internal lists instead of, or in addition to, OMRI and WSDA.

**Check whether the material or product you plan to use is currently listed or registered on one or more of the approved lists of Brand Name or Generic materials.**

Always use the most current information available. The websites of OMRI and WSDA listed on page six are best to verify any claim of listing. A very recent printed guide is next best. It is the organic producer or handler's responsibility to verify any claim of listing for compliance by checking it against current lists on the website. When in doubt, contact your certifier to determine the status of any material that you are considering for use.

**If the material/product you are interested in using is *not* on a current approved list, follow your certifier's instructions to verify its compliance.**

Work with your certifier to evaluate the material by providing supporting documentation (product label, Material Safety Data Sheet—MSDS, manufacturer's statement, and/or ingredient list with *all* ingredients including inert ingredients). You and your certifier will need sufficient information about the product and its production process to assess whether the material is allowed under the standards.

The NOP issued a memo to Accredited Certification Agencies on March 5, 2008 regarding "Verification of Materials" and documentation of such:  
<http://www.ams.usda.gov/AMSv1.0/getfile?dDocName=STELPRDC5066877>

## Maintain your OSP to be current and accurate by reviewing and updating it regularly.

The Organic System Plan is essentially a contract that includes written plans concerning all aspects of agricultural production or handling (NOP Section 205.201). Any materials used or planned for use must be in current compliance.

You should review and update your Organic System Plan at least annually or as changes are made. Keep a copy for yourself and submit any updates promptly to your certifier, as required by 205.400(f).

## Verify materials use in the context of the OSP.

In addition to materials, the OSP must also include a description of your production practices and procedures, monitoring, recordkeeping system, and prevention of commingling and contact with prohibited materials, and any other information as specified in Section 205.201. This other information provides the context under which a material may or may not be allowed for use.

Even if a given input is on a list that the certifier recognizes—whether WSDA, OMRI, or even their own list of materials—a certifier may still deny the use of a material in the context of the OSP.

### Excerpts from OMRI's website and publications explain their work.

The Organic Materials Review Institute (OMRI) is a 501(c)(3) nonprofit organization that specializes in the review of substances for use in organic production, processing, and handling. OMRI's services are directed to all aspects of the organic industry with a primary focus on the decision makers who deal with the compliance status of generic materials and brand name products. With the OMRI Generic Materials List and OMRI Products List, OMRI provides guidance on the suitability of material inputs under the USDA National Organic Program standards.

#### How products are reviewed

OMRI reviews applications from input suppliers for products in crops, livestock, and processing. To assess compliance with the National Organic Program Rule, OMRI requires product applications to contain all the relevant public and proprietary information regarding product ingredients, formulations, and manufacturing processes. OMRI operates under a rigorous confidentiality policy to guard against disclosure of proprietary product information to unauthorized individuals.

As a nonprofit organization, OMRI is able to offer an independent, third-party review of products that can balance the need for confidentiality in reviewing proprietary formulations with the necessity to ensure that products comply with the National Organic Program Rule.

The review process consists of two steps: review and recommendation by OMRI staff, and decision-making by an independent Review Panel. All products are reviewed according to published policies and standards.

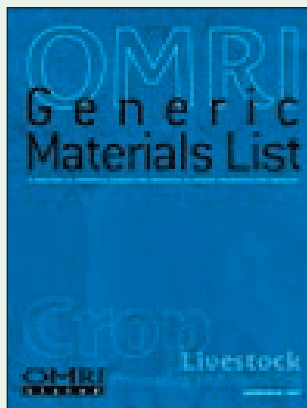

**M**any certifiers agree that OMRI Products Lists are invaluable tools to help find compliant materials. Find the most current lists on their website: [www.OMRI.org](http://www.OMRI.org).

## Materials Lists

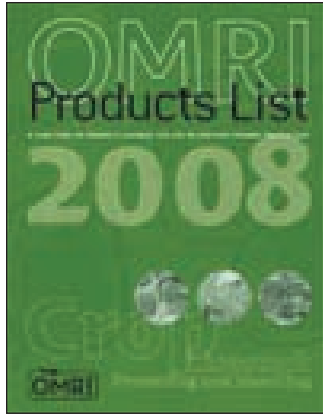

### A) The Organic Materials Review Institute (OMRI) Products List

[www.omri.org/OMRI\\_datatable.htm](http://www.omri.org/OMRI_datatable.htm)

OMRI's primary reference manuals are the OMRI Products List (brand name materials, available on their website) and the OMRI Generic Materials List (available for purchase on their website). These resources help interpret the NOP's National List and enable producers and processors to determine under what circumstances a material or product is allowed for use in organic production. OMRI lists are updated quarterly, and users should be sure they are using the most current version of the list. The most current product listings can be found on OMRI's website.

OMRI's services are valuable to facilitate understanding of materials and products that are consistent with the National List, even though OMRI is not officially accredited by the NOP. Inclusion on the OMRI Products List must be renewed every year by the manufacturer. Some products may be listed one year and not the next. Reformulations can render a product non-compliant. Alternately, a reformulation can bring a previously non-compliant product into compliance. In some instances, a producer will be required to document the lot number of a product in order to verify its compliance.

#### **Note:**

The U.S. Environmental Protection Agency (EPA) has issued a notice for how pesticide registrants can obtain EPA approval to identify products that comply with the NOP Rule for organic production and handling.

### B) Washington State Department of Agriculture Materials List

<http://agr.wa.gov/FoodAnimal/Organic/MaterialsLists.htm>

The Washington State Department of Agriculture (WSDA) registers several brand name materials for use in organic production and handling. WSDA provides the following explanation of their brand name lists:

“In order to comply with National Organic Standards, producers and handlers must use substances in compliance with National Organic Program requirements (7 CFR Part 205). WSDA Organic Food Program has evaluated the products on the Brand Name Material List (BNML) and determined that they comply with the National Organic Standards.

WSDA does not imply any guarantee or endorsement of any of the products listed on the BNML. In addition, manufacturers of these products are not required to list their products on the BNML. Therefore, this is not a comprehensive list of brand name materials that meet organic standards. Please refer to the National List of Allowed and Prohibited Substances for further information regarding materials for use in organic food production.”

### C) Your Certifier's List

Ask about whether one exists and how you can access its information.

The program is voluntary and many registrants of NOP-compliant products have chosen not to identify their products as such. For more information, visit the EPA's website:  
[www.epa.gov/oppbppd1/biopesticides/regtools/organic-pr-notice.htm](http://www.epa.gov/oppbppd1/biopesticides/regtools/organic-pr-notice.htm)



*Department of Agriculture also evaluates materials and maintains a list of allowed brand name products.*

## STEP THREE —

**Document every input material purchase and use, and keep those records for a minimum of five years.**

Input purchase records may include receipts or invoices, delivery tags, and receiving logs. Input application records must include Material (Brand name/formulation), Manufacturer/source, Crop, Location, Frequency, Rate and Quantity, Purpose (e.g. fertilizer, pest control), and Date Applied.

Your certifier may provide forms to facilitate documentation of input applications. Several types of sample documentation forms are also available from ATTRA:

ATTRA's *Record Keeping & Workbook* draft by Ann Baier and Holly Born [http://attra.ncat.org/downloads/organic\\_cert/recordkeeping\\_budgeting.pdf](http://attra.ncat.org/downloads/organic_cert/recordkeeping_budgeting.pdf).

ATTRA's workbooks, checklists, sample forms, and other guides for organic certification including documentation forms for livestock, field crops, market farms, and orchard, vineyard, and berry crops can be downloaded for free at <http://attra.org/organic.html>.

### Be Careful!

Prior to using any substance in an organic operation, carefully evaluate the status of the material according to the National List and the Brand Name Material List.

Some substances which were previously approved for use in organic systems are no longer approved.

Use of these substances is considered the use of a prohibited material and may result in a loss of organic certification for 36 months.

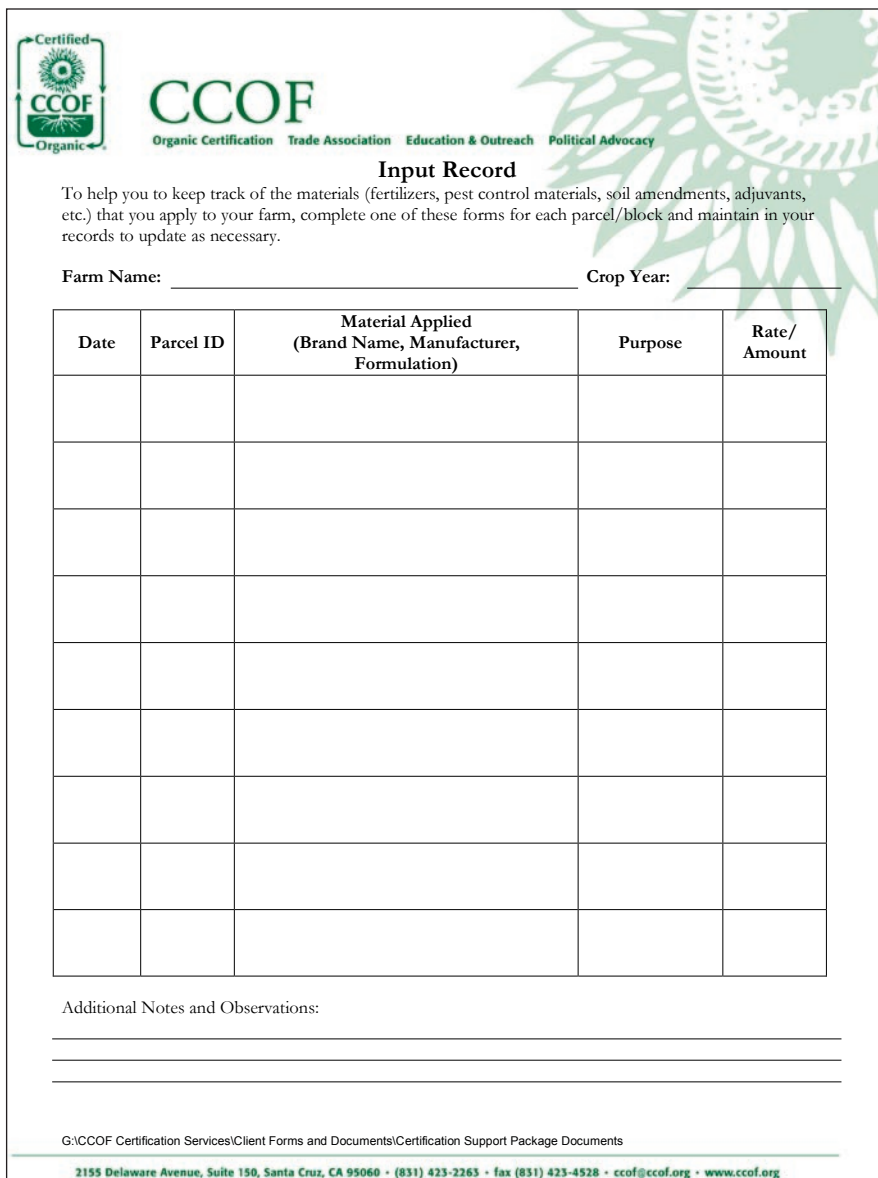

**CCOF**  
Organic Certification Trade Association Education & Outreach Political Advocacy

### Input Record

To help you to keep track of the materials (fertilizers, pest control materials, soil amendments, adjuvants, etc.) that you apply to your farm, complete one of these forms for each parcel/block and maintain in your records to update as necessary.

Farm Name: \_\_\_\_\_ Crop Year: \_\_\_\_\_

Date	Parcel ID	Material Applied (Brand Name, Manufacturer, Formulation)	Purpose	Rate/ Amount

Additional Notes and Observations:  
\_\_\_\_\_  
\_\_\_\_\_  
\_\_\_\_\_

G:\CCOF Certification Services\Client Forms and Documents\Certification Support Package Documents  
2155 Delaware Avenue, Suite 150, Santa Cruz, CA 95060 • (831) 423-2263 • fax (831) 423-4528 • ccof@ccof.org • www.ccof.org

Many certifiers have forms for tracking input use. One example is pictured to the left. It can be found among a collection of useful forms at [www.ccof.org/certificationassistance.php](http://www.ccof.org/certificationassistance.php)

**Special thanks for input and review from:**

**James Wynn and Brian Baker**  
Organic Materials Review Institute (OMRI)

**Miles McEvoy and Katherine Withey**  
Washington State Department of Agriculture  
(WSDA) Organic Program

**Jim Riddle**  
University of Minnesota.

**Organic Materials Compliance—**

**Materials for Organic Production, Handling, and  
Processing: Planning for Compliance with USDA's  
National Organic Program**

By Ann Baier and Lance Gegner  
NCAT Agriculture Specialists  
© 2008 NCAT

Karen Van Epen, Production

This publication is available on the Internet at:

[www.attra.ncat.org/attra-pub/organicmaterials.html](http://www.attra.ncat.org/attra-pub/organicmaterials.html)

or

[www.attra.ncat.org/attra-pub/PDF/organicmaterials.pdf](http://www.attra.ncat.org/attra-pub/PDF/organicmaterials.pdf)

IP313

Slot 312

Version 081808





# Pastures: Going Organic

A Publication of ATTRA - National Sustainable Agriculture Information Service • 1-800-346-9140 • [www.attra.ncat.org](http://www.attra.ncat.org)

By George L. Kuepper  
and Alice E. Beetz  
NCAT Agriculture  
Specialists  
© NCAT 2006

This publication is an introduction to regulations related to organic pasture and rangeland in the United States. Organically certified land is described under The National Organic Program, including activities and materials that are allowed or prohibited. Fertility, weed, and insect pest management issues are briefly addressed. Organic integrity is discussed, including records required to demonstrate compliance with the National Organic Standards. References and resources follow the narrative.

Introduction.....	1
What Does "Organic" Mean? .....	2
Organic as a Biological System .....	2
Organic Integrity .....	14
Conclusion.....	18
References .....	19
Further Resources .....	19

## Introduction

**T**his publication covers the major concepts and issues associated with the organic management of pasture and range. The focus is on compliance with U.S. National Organic Standards that govern use of the word "organic" in relation to pasture or range. A brief explanation of the biological basis of organic pasture/range management is followed by specific information about materials that can and cannot be used. The organic integrity section outlines how to ensure that a pasture is not contaminated with prohibited materials and how to document measures that ensure this.

This publication does not contain everything one needs to know in order to manage a ranch or pasture organically. There is much more information that will be important to specific circumstances. More information on how to manage livestock, pasture and range is available from many other sources, including several ATTRA publications listed within.



*Dense, diverse pastures produce healthy animals.  
Photo by Linda Coffey, NCAT.*

The National Center for Appropriate Technology (NCAT) offers an ***Organic Livestock Workbook***, available through the ATTRA Project. It offers a more detailed treatment of what is required and recommended for an organic pasture or range operation. Readers are encouraged to obtain a copy. The Workbook is a guide to all aspects of livestock production that must be addressed in order to comply with federal regulations.

### Definition: Pasture

The National Organic Standard defines pasture as land used for livestock grazing that is managed to provide feed value and maintain or improve soil, water, and vegetative resources [section 205.2]. Land is not pasture when any of the following are dominant characteristics:

- It is a drylot
- It is denuded of vegetation
- It is overgrazed

Ruminants must have access to pasture, according to the Organic Rule [section 205.239(a)(2)], and managers have the responsibility to maintain the ecological integrity of the pasture resource with proper grazing management. Certified organic hay is appropriate if the animals must be off pasture for management reasons. See the National Organic Standard for more information. [www.ams.usda.gov/nop/indexNet.htm](http://www.ams.usda.gov/nop/indexNet.htm)

## Related ATTRA Publications

Organic Farm Certification and the National Organic Program

Preparing for an Organic Inspection: Steps and Checklists

Forms, Documents, and Sample Letters for Organic Producers

NCAT's Organic Crops Workbook

NCAT's Organic Livestock Workbook

National Organic Program Compliance Checklist for Producers

Organic Livestock Documentation Forms

Organic Marketing Resources

Pastures: Sustainable Management

Nutrient Cycling in Pastures

Assessing the Pasture Soil Resource

Rotational Grazing

Dung Beetle Benefits in the Pasture Ecosystem

Multispecies Grazing

A Brief Overview of Nutrient Cycling in Pastures

Pasture, Rangeland, and Grazing Management

A large portion of the workbook is dedicated to pasture management. Emphasis is placed on biologically and economically sustainable systems.

## What Does “Organic” Mean?

As of October 2002, the definition of “Organic” has been established as part of federal standards for organic agriculture. The National Organic Program (NOP) defines organic production as: “A production system that respond[s] to site-specific conditions by integrating cultural, biological, and mechanical practices that foster cycling of resources, promote ecological balance, and conserve biodiversity.” (NOP 205.2 definition of Organic Production).

The word organic is now legally defined by the National Standard as published in the Code of Federal Regulations. It is now illegal to market any agricultural product as organic or to advertise a farm as organic unless the producer is in full compliance with these regulations.

Contrary to popular myth, organic agriculture originated in the early part of the 20th century, not in the 1960s. The people who founded and promoted it were concerned with a wide range of agricultural problems, including a decline in soil fertility, increased erosion and pollution, and an increase in degenerative diseases in society as a whole. They believed that the growing use of soluble fertilizers and chemical pesticides would not only fail to address these problems, but would only make them worse.

These founders established a core philosophy that is fundamental to organic production today—that people cannot be healthy unless they eat healthy food, and healthy food can only come from healthy, vital soil. For a soil to be vital and healthy it has to be alive with biologically active, organic elements.

Proponents of organic agriculture recognize two interrelated and interwoven objectives of this type of farming. The first is that the farming or ranching system works on natural principles. The second objective is to ensure prevention of

contamination of that system by prohibited substances, either in the field (production) or in the marketing and handling process. Preservation of the identity—and integrity—of organic products means that organic products must not be mixed with any conventional products from the farm. Both of these objectives are important.

## Organic as a Biological System

### *The Soil Food Web*

The Soil Food Web is a recently coined term that describes the marvelous, intricate underground ecosystem that includes earthworms, fungi, bacteria, insects, and many others—both plants and animals—that make up a living soil. These are the regenerative agents that build soil. Their basic food is organic matter and the mineral nutrition bound up in organic matter.

These soil organisms provide countless services that benefit the plants growing above the ground.

- They recycle the nutrients in plant residues and animal wastes by converting them gradually over time



*Earthworms, insects, fungi, nematodes, bacteria, interact with each other as well as with plant roots and soil components to create the Soil Food Web.*

back into soluble forms available to plants.

- They fix nitrogen from the air.
- They create a host of natural antibiotics, vitamins, and other compounds that add to plant nutrition and help control soil pests and diseases.
- They also create organic acids that release even more nutrients from the parent rock material of the soil and subsoil.

### ***Natural, Conventional, and Organic Approaches to Plant Nutrition***

The organic approach builds healthy soil and provides nourishment to crops. This approach is based on an understanding of how plants are fed under natural conditions. Under natural conditions, plants get their necessary minerals from the action of the whole complex of organisms that make up the Soil Food Web.

Conventional fertilization attempts to bypass the Soil Food Web by providing nutrients already in a soluble form. When this approach is taken, the activity of the Soil Food Web often declines, because it needs to be fed through additions of organic matter. (Ingham, 2004) Pesticides and many conventional fertilizers are also directly toxic to soil organisms, which reduces their populations even further.

The soil's humus content also declines as does its ability to provide nutrition to the crop. As the soil loses its natural digestive capacity, the system becomes increasingly dependent on soluble fertilizer to function. Additional consequences of a depleted Soil Food Web and reduced humus level include poor soil structure, poor drought tolerance, increased erosion, and increased pest and disease problems.

In contrast, organic farmers and ranchers work to enhance and build the Soil Food Web. The health of the Soil Food Web is improved primarily by feeding it with organic matter, by providing deficient nutrients, and



*Healthy, living soil produces forages that in turn support healthy livestock.  
Photo by Alice Beetz, NCAT.*

through adjustments to soil pH. In addition, organic farmers and ranchers avoid the use of pesticides, anhydrous ammonia, and other materials harmful to the organisms that make up the Soil Food Web.

Additional benefits of the organic approach include balanced plant nutrition (not just nitrogen, phosphorus, and potassium and the other few elements that synthetic fertilizers may provide), reduced nutrient leaching, and a natural pest control.

Organic farming is often described—by those not familiar with the National Organic Standards—in terms of what is prohibited. It is identified as farming without synthetic fertilizers and pesticides. This presents a false picture. From its beginnings, organic farming has been a deliberate approach to agriculture that focuses on soil management. You can sum up the strategy in a phrase that organic farmers have used for decades: “Feed the soil.” When they talk about feeding the soil, they’re talking about feeding the Soil Food Web.

Many descriptions of organic culture are based on vegetable or grain crop production. Some of them translate well to

### Crop Production Standards Apply to Pasture

Pasture is a crop whether it is harvested by animals through grazing or made into hay, silage, baleage, etc. All the standards relevant to crop production apply to pasture. These include:

- Crop production standards (NOP Sections 205.200 - 205.206)
- Organic Systems Plan
- Land requirements: transition and buffers
- Soil fertility and crop nutrient management
- Crop rotation
- Pest, weed, and disease management
- Seeds and planting stock
- National List of allowed and prohibited materials (Sections 205.600 - 205.603)
- Recordkeeping (Section 205.103)

pasture-based production; some do not. When it comes to managing organic matter, pasture based systems have a great advantage over tillage agriculture.

Tillage over-stimulates the Soil Food Web, causing humus to oxidize and “burn up” more rapidly. Unless a considerable volume of organic matter is supplied to tillage

systems to compensate for these losses, humus levels will decline along with the volume and diversity of the food web. Because pasture systems receive little or no tillage, they do not face this problem.

A well-managed organic pasture enjoys not only the benefits of a Soil Food Web undisturbed by tillage, it also receives regular and substantial inputs of organic matter from various sources.

Plant residues from root dieback and from surface accumulation are important. Good rotational grazing practices create cycles of growth and dieback for the extensive grass root systems, contributing greatly to soil building. After each grazing period or hay harvest, some of the forage roots die, becoming food for the organisms in the soil.

Good grazing management—which also serves to create a dense stand of forage—contributes to soil humus building in another way. Pasture plants are known to contribute as much as 25 percent of the carbohydrates they produce through photosynthesis as root exudates. These exudates, in turn, feed the soil organisms so that they can provide more of the benefits listed above. (Ingham, 2000) Therefore, more plants growing on the pasture means a better-fed underground ecosystem.

### Contributions of Organic Matter to the Food Web in a Pasture

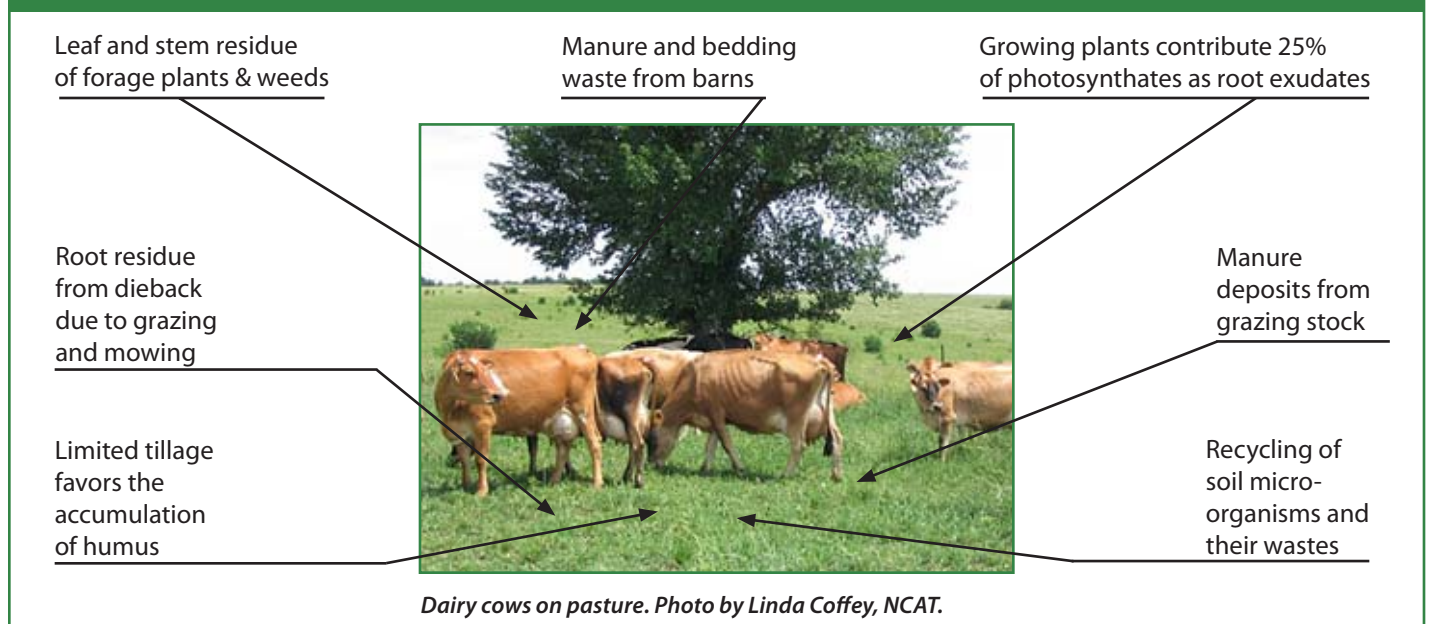



High stock density followed by adequate rest contributes to root growth and dieback cycles that build soil. Photo by Alice Beetz, NCAT.

Grazing livestock also contribute manure as organic fertilizer. Since this manure is generated on-site from the pasture itself, it is really a form of nutrient cycling or recycling. Some organic operations also import manures, compost, or other organic-rich materials from other farms in the region. When reasonably priced, locally available manure can be a terrific resource. Once established, however, a well-managed pasture-based system should grow on-site all

the organic matter to meet the needs of a healthy Soil Food Web.

### ***Nitrogen in Organic Systems***

As in conventional farming, nitrogen is usually the limiting nutrient in production. Nitrogen is supplied in agricultural production from a wide variety of natural and human-controlled sources. However, in conventional management, a great tendency is to rely on synthetic ammonium, nitrate, and urea fertilizers for all the nitrogen required.

Imported nitrogen is falsely believed to be the only way to get needed quantities. Some producers try to buy up all the manure they can find and apply it at levels designed to meet their nitrogen requirements. This can lead to overloading the soil with phosphorus, potash, or other nutrient elements. In the mid-South, for example, this practice has created water quality problems because of phosphorus buildup from continuous use of poultry litter on pastures. The most economical source of nitrogen in organic systems is homegrown legume nitrogen. If your goals and circumstances allow,

#### **Inoculation with Nitrogen-Fixing *Rhizobium* Bacteria**

*Rhizobium* species of inoculants are commonly used to increase the effective nodulation of legume crops and cover crops, including clovers, alfalfa, peas, vetch, birdsfoot trefoil, and others.

These bacteria are often present in the soil naturally. However, inoculation is probably worthwhile for a specific legume planted on a new piece of ground not recently planted with that crop. It's a small cost and can help increase legume plant productivity.

Legumes and rhizobium bacteria develop a mutually beneficial relationship through formation of root nodules. Through a biological process inside these nodules, nitrogen gas from the atmosphere ( $N_2$ , a form of nitrogen that cannot be taken up by plants) is converted into ammonia ( $NH_4^+$ , a form that plants can use). The bacteria in turn get sugars that the plant produces through photosynthesis. The plant gets available nitrogen from this arrangement, something it can't make for itself.

There are many species of rhizobium bacteria, and each is adapted to form this kind of relationship and make good, productive nodules with only one—or a small group—of

legumes. For example pea/vetch inoculant is a different species from alfalfa inoculant. Rhizobium bacteria can be purchased as an inoculant, usually in a small bag with peat moss as a carrier. It is very important to keep the inoculant cool. The refrigerator is a good place. Bacteria are living, and they will die if they get too hot. The inoculant is usually applied by mixing it with the seed—either wet or dry—right before planting. That way, the bacteria will be near the plant roots with which they will form a symbiotic relationship.

You can tell if the nodules are effective little natural fertilizer factories by digging up a plant, finding nodules, and checking the color inside. If you see pink tissue when you cut open a nodule, that's a good sign. The red color indicates the presence of leghemoglobin, whose function is similar to the hemoglobin in animal blood. It helps maintain oxygen flow to the bacteria so they can fix nitrogen.

Genetically modified inoculants have reached the market. Before you buy inoculant, get written documentation of its non-GMO status to protect your organic certification eligibility. Be sure that the one you buy is a naturally occurring bacteria.



*Maintain legumes as about 30 percent by weight of the pasture by adjusting pH and soil minerals. Graze so that grass doesn't shade out the legume. Photos by Linda Coffey, NCAT.*



*To establish a new legume, coat the seed with the correct inoculum, but be sure it's approved for organic production.*

manage pastures to promote legume production. It is a giant step toward sustainable, organic management.

### ***Legume Nitrogen***

If you don't have existing populations of desirable legumes, over-seed or even reseed pastures with these plants. Legume root nodules can capture nitrogen from the air for their own use. Seed inoculation may be necessary to establish a healthy population of rhizobium bacteria appropriate to the species of legume you wish to grow. These bacteria grow in root nodules and are able to capture nitrogen from the air and convert it into a form the legume can use. Producers benefit enormously by inoculating seed, particularly under the following circumstances:

- The pastures have not grown legumes in several years
- The existing rhizobium species are not of the same inoculation class as the one needed by the legume being over-seeded
- Current legumes show poor nodulation

To develop a legume-based pasture system, you must manage for legumes. Soil fertility and grazing must be managed to favor

legume growth. Soil tests indicate calcium levels and will also show whether to adjust the pH with lime to be more favorable to legumes. Lime is very important since most high-value legumes like alfalfa and the clovers need calcium. Tests also indicate the presence of other essential nutrients that legumes need to thrive. The lack of phosphorus and sulfur can limit good legume growth in certain soils.

For best pasture quality for grazing animals and optimal renewal of soil fertility and health, a good goal is that legumes be 30 percent (by dry weight) of the forage population. At this level, legumes provide plenty of nitrogen to their neighboring forage plants. Keep the grass grazed short enough that it doesn't shade out the legumes. If the legume is an annual, it must be allowed to reseed each year—or at least every other year.

### ***Managing Manure in the Pasture***

Finally, optimize the recycling of nitrogen. Manage the manure resource well, so that the nitrogen you grow stays in the field and is available to the growing plants, even if it cycles through the livestock first. Animals tend to gather and rest in favorite areas, such as near a water source, by the minerals, or



*Moving minerals and water sources around in a paddock prevents manure buildup in these popular areas. Photo by Alice Beetz, NCAT.*

in the shade. Try to keep from transferring and concentrating nutrients from the field to these favorite spots by moving the minerals to different areas in a paddock. Moving the water source and the shade provides the same advantages. Refer to ATTRA's publications on nutrient cycling (see the ATTRA publications list on page 2) for a more thorough treatment of the subject.

### **Supplemental Nitrogen Fertility**

To supplement nitrogen fertility, find a natural source of nitrogen for organic production. Be aware that almost all synthetic nitrogen sources are prohibited in organic production. This includes synthetic urea, ammonium sulfate, and liquid synthetic formulations such as 9-18-9. Sales people may tell you these are easy on soil organisms and they're possibly right, but the products are also "synthetic" and are therefore prohibited. However, some liquid fertilizers like fish emulsion and compost tea are made from natural ingredients. While these are allowed in organic production, they are probably not very practical or as cost-effective for pasture production as other sources of nutrients.

Manure and composted manures are the most common sources of imported nitrogen. You may use manure and composts

from conventional confinement operations. Manure does not have to come from organic animals. However, if a certifier suspects a high level of contamination with prohibited substances, you may have to have the manure or other material tested, and further use may be denied. That is a judgment call on the part of the certifier.

### **Managing Phosphorus, Potash and other Essential Nutrients**

As pointed out earlier, organic management is designed to accelerate natural chemical and biological processes in the soil, making nutrients from the native soil more available. These processes include recycling nutrients, and making the pasture as self-sufficient in fertility as possible. Some organic farms are quite successful in reaching or at least approaching a closed-loop fertility system—especially for nitrogen. Most farms, however, need to supplement soil nutrients, usually because of soil type, the intensity of production and export of nutrients, or the effects of prior management. Soil and forage testing can be valuable tools in this effort.



*Use soil and/or forage tests to monitor and balance soil nutrients. Photo courtesy of USDA-NRCS.*

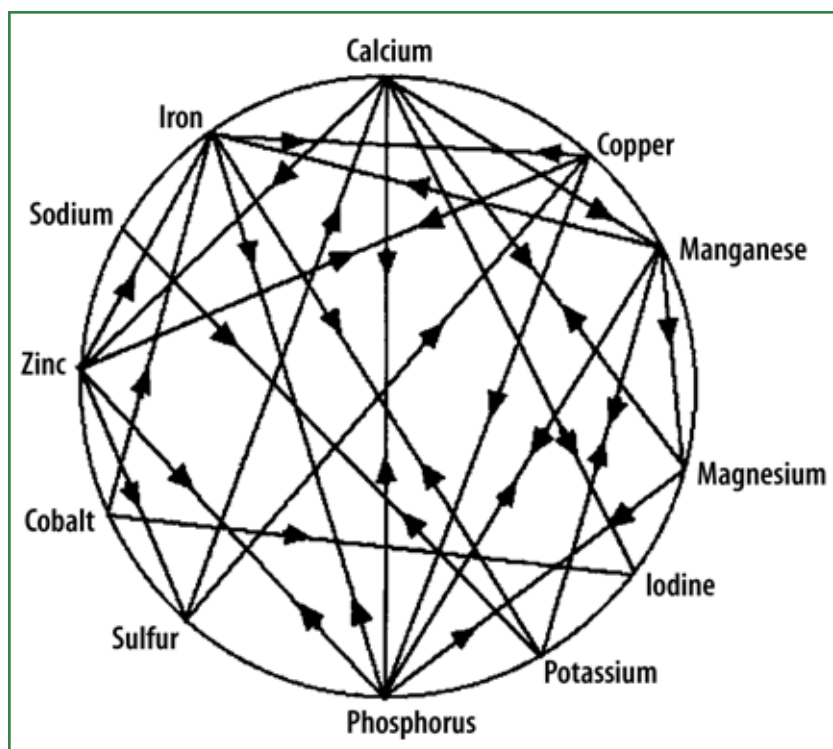

Too much or too little of any mineral affects other nutrients as well as forage and livestock health.

Figure from: Holliday, R.J. "Let your animals teach you nutrition." *Organic Broadcaster*. May–June 2002.

It is wasteful to purchase nutrients your soil may already have in abundance.

When supplemental fertility is necessary, nutrient needs can often be met with manure or compost—assuming it is sufficiently rich in the minerals your pastures need. Natural rock powders are the next most valuable input. As with anything you use on your pasture, you should identify and document the sources in order to show it is natural and not synthetic. For example, natural forms of lime are allowed as a soil amendment. Hydrated lime is a synthetically processed product and is therefore prohibited. Natural mined gypsum is allowed, but recycled gypsum wallboard is not. Potassium sulfate is allowed if it is from a natural mined source; the synthetic form is prohibited.

Document the source of any mineral you use. Wood ash is allowed if it is from natural untreated wood, but not if plastics and other synthetic materials were also in the fire. Micronutrients are often overlooked. You probably don't need to test for them

very often, but do so often enough to know whether a micronutrient is deficient or at an excessive level. High levels can present a risk of toxicity; low levels can cause forage or animal health problems.

Another reason soil testing can be important is nutrient balance. The mineral wheel (see above left) presents a visual concept of how each nutrient affects others. The soil is a living thing; imbalances have consequences. For this reason, many organic livestock producers use soil laboratories that provide a full cation nutrient profile. They use a system known as the Albrecht approach. It is not in universal use in organic production, but it is a popular way to monitor and manage soil nutrients.

### **Soil Amendments and the Organic Rule**

As previously mentioned, most conventional fertilizers are considered synthetic and are prohibited in organic production. This includes ammoniated fertilizers, super phosphate, nitrates, and common blends such as 13-13-13, 9-18-9, and so forth. Ash from manure burning is specifically prohibited as is the use of sewage sludge. Organic material that has been contaminated by heavy metals or other materials is prohibited.

This issue can arise with the use of manure from factory-scale and factory-style productions. Contaminants may be an issue with poultry litter anywhere throughout the country. Most conventional poultry producers use arsenic as a feed additive to control parasites and stimulate growth. Much of the arsenic passes through the birds and into the manure.

Other materials applied to poultry litter to prevent volatilization of nitrogen can also cause problems for organic producers. Hormones used to supplement dairy animals can also be an issue. These manures may be seen as contaminated with a prohibited material for organic production. Though not routinely done, a certifier may require testing of manure if there is reason to suspect unacceptable levels of contamination. These are especially important



considerations if the producer seeks international certification to export products to Europe.

Finally, genetic engineering is also prohibited in organic production. Genetically engineered seed, inoculants, or soil amendments are regularly marketed. Obtain documentation that no genetically modified organism (GMO) or GMO-derived matter is contained in your sources. Note that the prohibition on GMOs has practical limits. Unless otherwise contaminated, there is no regulation against using manure from animals that have been fed genetically engineered crops.

A few synthetic materials are allowed in organic agriculture with specific restrictions. Each of these is listed in the National Organic Standards section 205.601 with specific annotations about how they may be used in organic production. Micronutrients are one example of allowed use of synthetic materials in organic production. Only certain forms of micronutrients may be used. These are listed in NOP section 205.601(j)(6) and a need for them must be documented by testing (soil or tissue tests).

Fish emulsion, seaweed extract, and humic acids are commonly believed to be natural products. While the basic ingredients in these products are natural, the process by which they are manufactured may involve synthetic materials. The regulations articulate the specific applications for which certain synthetic materials are allowed. For example, “Liquid fish products—can be pH adjusted with sulfuric, citric, or

phosphoric acid. The amount of acid shall not exceed the minimum needed to lower the pH to 3.5” (NOP 205.601 (j) (7)). This acid solution helps break down fish byproducts and makes nutrients more available in fish emulsion. The National Standard permits the use of these materials in the production process, but not to “enhance” the products with synthetic fertilizers or other prohibited substances.

You are not likely to be using it on pastures, but sodium nitrate is a natural mineral that is restricted to no more than 20 percent of a crop’s nitrogen requirement. There are some forms of muriate of potash that can be used. They are hard to find. You can assume that most widely available commercial grades of potassium chloride are prohibited forms.

Be careful about what you buy. There are loopholes in our fertilizer laws that allow materials with any nutrient content to be sold as micronutrient fertilizers. Some are being sold as fertilizers, even though they might actually qualify as toxic waste under EPA classifications.

## ***Organic Strategies and Considerations for Weed Management***

For most organic cropping systems, weeds are considered the greatest challenge to production. Unlike vegetable and row crops, pasture systems have a higher tolerance for weeds. In part, this is due to the fact that

### **Keeping Pastures Healthy - Self-regulation and sustainability in pasture systems are best accomplished through the following weed management strategies:**

- Improve the soil organic matter
- Understand the causes, life cycle, and feed value of the weed
- Increase species diversity in the pasture
- Graze during the time of a weed’s maximum palatability
- Practice high-intensity grazing and high frequency of grazing
- Graze several complementary livestock species
- Introduce biological weed control agents
- Mow, hand weed, and dig to remove weeds mechanically
- Use flame weeding or other forms of heat destruction
- Rotate into annual crops



*Managed grazing prevents many weed problems as livestock learn to eat weeds in their young, palatable stage. Photo by Linda Coffey, NCAT.*

many weeds have nutritional value and are palatable at some stage in their life cycles. It's worthwhile to rethink which plants you consider to be "weeds."

Organic Standards (NOP 205.206) describe pest management (including weeds), in terms of three main approaches. First, cultural practices prevent pest problems at the systems level. For instance, rotational grazing provides a system effect of improved weed pest management. Second, mechanical and biological responses can be used to manage pests. Examples include the use of physical or mechanical practices, such as flaming to control alfalfa weevil, and biological controls

#### **How Do Weeds Get Started?**

When grasses are grazed, a portion of the root mass dies and decays. This process has some ecological benefits in that it allows underground nutrient cycling and opens passages for water and air to move freely to supply other plants with nutrients and oxygen. However, if a plant is grazed repeatedly and has no time to re-grow, it loses more root mass than it can tolerate, and plant health and vigor decline. This situation gives other, often unwanted, plants a chance to germinate and take root.

such as multispecies grazing. Several specific suggestions are listed in the standards for weed management.

### ***Cultural Practices for Weed Management***

Good organic soil management and a healthy Soil Food Web result in weed control benefits. Some weeds are favored by tight anaerobic soil conditions, extremes of acidity or alkalinity, or low organic matter. These species will be discouraged on well-managed organic soils. Weed seed viability is also reduced on biologically active, organically managed soil, according to recent research. (Anon. 2000)

Learn about the weeds. First, consider whether the "weed" is really a problem in your grazing system. Some weeds have very deep taproots and bring up nutrients that livestock need. If these plants are palatable, consider them a valuable part of your forage system. If the weed truly is undesirable, learn as much as you can about it. Where did the seed come from? Can you prevent further infestation? What conditions does this weed prefer? Can these conditions be changed? Try to identify the point in its life cycle when it is most vulnerable, and target your efforts to that time. Many weeds are palatable during early stages of growth, and grazing keeps them from going to seed.

A mixed-forage pasture provides more protection against weeds than a single-species pasture. A diverse pasture utilizes all the available space, nutrients, and water at various levels both above ground and below ground. Mixed stands stay weed-free longer than pure stands because of the increased ecological diversity. Nature always tries to restore species complexity, a concept known in ecology as succession. For instance, a field planted to alfalfa, orchardgrass, and timothy is better than a pure stand when it comes to weed suppression. Clover, birdsfoot trefoil, alfalfa, or other legumes as a 30 percent mix with two or more grasses provides a higher nutrient content than pure stands. It also offers a longer grazing season.

Good grazing practices—especially rotational grazing—go a long way to discourage weed competition. The rhythm of grazing and rest creates lush, dense pastures with little space or light for weeds to become established. See ATTRA’s publications *Rotational Grazing* and *Pastures: Sustainable Management* for a more complete treatment of this subject.

High stock density encourages animals to graze the pasture more uniformly than lightly stocked pasture. “Weedy” species are grazed at the same intensity as “good” species. Because the growing points on grass plants are located below the normal grazing level, high density stocking favors grass growth. The growing points on broadleaf weeds are higher and are grazed off. This sets up a competitive advantage for grasses. Broadleaf weed populations tend to decrease under intensively grazed systems. Since legumes and some other desirable forages are broadleaves, special effort must be taken to preserve them in the pasture mix as you work to eliminate weed species.

Be careful not to introduce new weed seeds into paddocks that don’t have them. If you feed hay on pasture, be sure it doesn’t contain viable weed seeds. Similarly, livestock moved from a weed-infested paddock can carry weed seed and deposit it with manure. Even equipment can carry seeds from paddock to paddock.



*A few years of pasture in a crop rotation interrupts the life cycle of weeds that have adapted to either the perennial or the annual system. Intensive grazing favors grasses and discourages broadleaf weeds in the pasture. Photo by George Kuepper, NCAT.*



*A healthy, weed-resistant plant community consists of a diverse group of species occupying all the niches (sites) and using all the resources in the system, keeping them from weeds (Sheley et al., 1999). Photo by Alice Beetz, NCAT.*

## **Mechanical Means of Weed Management**

Although more expensive than cultural practices, mowing, brush-hogging, pulling, and hoeing are traditional mechanical means of weed control. Flaming, a newer method of burning out the undesirable plants from an area, can be accomplished either with backpack or over-the-top equipment. These are all allowed practices in organic settings. Each may be appropriate for specific applications, depending on the weed species and the extent of its spread. For further information see the ATTRA publication on flame weeding.

Finally, rotating to an annual forage or crop that requires tillage presents the opportunity to completely renovate a pasture that has been invaded by toxic or noxious weeds. You will be able to choose among new, improved varieties of the forage species you want in your grazing system. Traditional farming systems include long rotations that plan for several years in pasture between annual cropping cycles. Tillage, however, comes with risks to the soil ecosystem as well as opportunities for further



Mixing types of animals that prefer different forages helps control weeds, breaks parasite cycles, and increases potential profitability.  
Photo by George Kuepper, NCAT.

weed invasion, so focus first on improved grazing management if the pasture is not already in such a long crop rotation.

### ***Biological Control of Weeds***

Multi-species grazing offers several benefits, including weed management. Goats, for example, are good at cleaning up brushy weeds. Sheep prefer broadleaf forages to grass, graze closer to the ground, and can be grazed on the same pastures with cattle. Because of their different forage preferences, small ruminants can often be added to a pasture system without decreasing the cattle stocking rate.

Even noxious, introduced weeds can be controlled and eventually eliminated by repeated, intensive grazing through species such as sheep or goats. These animals have mouth parts that can graze close to the ground, and they exhibit broad forage preferences. The ATTRA publication *Multispecies Grazing* offers a further exploration of this option.

Some weed species have parasites or predators that have been developed as weed control options. Among these are some thistles, leafy spurge, and the knapweeds.

Buying and releasing these biological control agents can be costly. In addition, they usually require several years to establish in an extensive pasture or range situation. Even when effective, they are usually considered one of several tools in a weed management system. Further information about insects for biological weed control is available from ATTRA or your Extension service.

### ***Forage Diseases and Insect Pests***

Compared to row crop and horticultural systems, pastures typically have a limited number of insect and disease problems. Under good organic management, a high degree of biological control is seen and many potential problems simply do not emerge.

When they do, they can often be tolerated. Sometimes, however, pest problems can't be ignored. The three-level approach: 1) cultural control practices, 2) mechanical methods, and 3) biological agents should be tried before considering the application of a material for control purposes.

Only when the cultural, physical, and biological defenses fail is it time to consider allowed pesticide materials. Materials are a complement to—not a substitute for—good management, and they usually add to the cost of production. Materials may be used only when other methods are not effective and when the conditions for their use are

#### **Related ATTRA Publication**

##### ***Farmscaping to Enhance Biological Control***

This publication contains information about increasing and managing biodiversity on a farm to favor beneficial organisms, with emphasis on beneficial insects. The types of information farmscapers need to consider is outlined and emphasized. Appendices have information about various types and examples of successful "farmscaping" (manipulations of the agricultural ecosystem), plants that attract beneficials, pests and their predators, seed blends to attract beneficial insects, hedgerow establishment and maintenance budgets, and a sample flowering-period table.

described in the producer's Organic System Plan (OSP) as approved by the certifier.

Sorting out what commercial pesticide products you can and can't use is even more difficult than it is for soil amendments and fertilizers. The more you can avoid pesticides, the better off you'll be. But if you should need to include such inputs, here are things you need to know.

The National Organic Standard describes what may and may not be used as a control agent. Allowed natural materials typically fall into three classes—minerals, biologicals, and botanicals. Among the few allowed synthetics are mineral formulations of copper and sulfur, and insecticidal soaps. It is unlikely that these would be used in a pasture situation. There are a few natural materials you are NOT allowed to use. These are listed in NOP 205.602.

### ***How to Tell What Is Allowed and What Is Prohibited***

Remember that the heart of organic production is not so much about materials as it is about management. Nonetheless, when materials are used, understand what is allowed and prohibited under the standards for organic production. Sometimes it is difficult to know whether a product is natural or synthetic, allowed or prohibited, especially if it contains inert ingredients that are not disclosed on the label. There are three approaches to determine whether a commercial product you plan to use is an allowed material.

- **First, read the pertinent parts of the Regulation.** This is your best option if you know all the materials and whether they are synthetic or not. The Web site of the National Organic Program ([www.ams.usda.gov/nop/IndexIE.htm](http://www.ams.usda.gov/nop/IndexIE.htm)) includes the complete standards.
- **Second, look at a current Organic Materials Review Institute (OMRI) Brand Names list.** The OMRI Web site ([www.omri.org](http://www.omri.org)) offers its Brand Names list



Learn which products are approved and discuss your Organic System Plan with your certifier. Photo by Ann Baier, NCAT.

indexed three ways—as materials, by company name, and by product name. Clearly, use of the Web site is free. OMRI also publishes a Generic Materials List which is very useful and available for a fee.

The OMRI list is not static. New products are added all the time and some products drop off—either because the manufacturer has changed the formulation or because they chose not to reapply to have a product listed. (The OMRI seal on a product indicates that it was “OMRI Listed” at the time it was produced.) OMRI reviews products for use in organic production, and its seal is an excellent indicator of acceptability. However, OMRI listing is a fee-based service and only companies that pay for it are listed. Many acceptable products have never been reviewed by OMRI and are not OMRI listed.

- Finally, **consult your certifier** anytime you are uncertain whether a substance can be used in production. According to the standards, materials you plan to use must be



*Treated wood is prohibited for new fencing in organic pastures, but existing treated wood fencing is often allowed. Photo by Ann Baier, NCAT.*

in the Organic System Plan (OSP) that you submit to your certifier. This plan must be approved by your certifier. Keep your plan up to date. If you plan to use a new product or material, submit an updated OSP to your certifier and be sure use of the material is approved before you use it. A few certifiers provide lists of allowed and prohibited products. But such lists are rarely comprehensive since so many new materials continue to come on the market.

Ask questions before you develop and submit an OSP to your certifier.

Also, verify with your inspector that the materials you list in your plan are allowable when you review it at each annual inspection. Never use a material without first adding it to your OSP and having it approved by your certifier.

## Organic Integrity

This publication began with a focus on organic production as a biologically based system. Now we begin to concentrate on matters that deal more with organic integrity. A discussion of land requirements for certified production serves as kind of transition; both faces of organic production are addressed here.

### Land Requirements

To begin with—and this is probably obvious—any field or farm you seek to certify must have distinct boundaries. You must submit a map to your certifier as part of your organic system plan. Certification is tied to the land as well as to your management and record-keeping as a producer. You may sell or rent organically certified land to another party and that property

will immediately be recognized as transitioned to organic. If you acquire new property, clear documentation of its land use history and all materials used in the previous three years must be obtained. If you don't have such documentation, that distinct piece of property will need to go through a transition period of its own before it is considered organic.

### Fencing

Fences have already been mentioned; however, fence construction has not. The National Organic Standard prohibits the use of treated wood in organic production where it can contact organic soil, crops, or livestock. This affects new installations. If you are transitioning to organic production and you have old treated wood fencing, most certifiers will readily allow that and prohibit the use of treated wood for new or replacement uses. (See ATTRA's publication entitled *Organic Alternatives to Treated Lumber*.)

### Transition Period

The period of organic transition is 36 months from the last time a prohibited material was applied, until harvest of the first crop as organic. In other words, the pasture forage is not considered organic until 36 months have passed.

### Soil Protection

We briefly discussed organic approaches to soil fertility above. No matter what actions or techniques you use, the soil resource must not be depleted. The Standard requires that you do some form of monitoring to ensure that organic matter and nutrient levels are maintained or improved under your management. Likewise, erosion must be controlled, and the land must be managed in a way that prevents pollution. The levels of manure you add must be agronomic rates and cannot contribute to runoff or leaching problems.

### Maintaining Organic Integrity

The Rule states simply, "Any [organic] field or farm...must: (c) Have distinct, defined

boundaries and buffer zones such as runoff diversions to prevent the unintended application of a prohibited substance to the crop or contact with a prohibited substance applied to adjoining land that is not under organic management.”

Organic integrity is about ensuring that the product you are raising organically stays that way until it is in the hands of the consumer. With organic pasture, the greatest threats to organic integrity typically come in the form of pesticide drift from neighboring farms, from road and utility maintenance, or—if you have a split operation—from your own conventional enterprises. If you are entirely organic and are adequately isolated from conventional chemical farming activities, you really don’t have an issue.

Isolation is the best insurance for organic integrity. Most, however, will not be isolated and may need to buffer production areas. That is easier said than done. If a neighbor does a lot of spraying or other chemical applications, you may need to set your border fence back from the field edge. The Regulations do not specify how wide such a buffer must be, only that contamination must be prevented. Twenty-five feet used to be customary, but that probably isn’t adequate if a neighbor aerial sprays. This is



Keep livestock out of ponds for good quality drinking water that supports better livestock health.  
Photo by Linda Coffey, NCAT.

## Timeline for Transitioning a Ranch Operation

### LAND

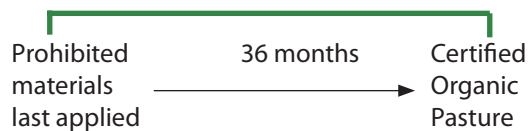

### ANIMALS

*This timeline illustrates how to coordinate organic pasture certification with organic livestock feed requirements. The 36-month requirement must be met by the time that the mothers reach the last third of gestation. The Rule states that they must be eating only organic feed from that time on.*

one of those things that will require clear communications with your neighbors and with your certifier.

Other measures may be needed if a neighboring farm’s runoff crosses your property. Water that drains from conventionally managed land onto yours must be kept from organically certified pastures and livestock. You may need to put in some sort of diversion, or perhaps create a flow-through grassed waterway that is fenced off so that it can’t be grazed. Water that leaves your land should run clear and show no signs of eroding soil. Usually the best way to handle these issues is to establish effective lines of communication with your neighbors whenever possible.

One can also put up “do not spray signs” along roadsides. Working with your neighbors or with utilities through some combination of notification and communication is one of the best things you can do. If you don’t have a chip on your shoulder, people can be remarkably cooperative. In the case of utilities and roadside maintenance, you may need to assume responsibility for mowing some weeds, but that seems a reasonable trade-off.



Work with road maintenance crews to prevent overspray on certified organic land.  
Photo by Ann Baier, NCAT.

Producers must decide whether they would rather lose land from production or harvest and sell buffer crops as conventional. The answer may depend on whether the buffer area in question is ten feet around a one-time spot treatment of herbicide on a thistle on your neighbor's side of the fence, or a 25-foot swath the length of a quarter section. As long as the organic crop is protected, producers can usually decide whether it is worth their trouble to clean or purge equipment (such as balers), and separate the crop from harvest

through transport and sale, documenting the sale of that crop as non-organic.

Another question that is sometimes raised is whether grazing conventional livestock affects the status of an organic pasture. As

previously discussed, manure from conventional sources may be applied (unless there is concern about contaminants as discussed above). Manure may be deposited directly on the land by grazing conventional animals, as long as the land is managed organically. Obviously, you would not be allowed to place conventional pesticide dust bags or backrubbers on an organic pasture site, or do anything similar that could lead to contamination of the land with prohibited substances. Animals should be removed from the pasture for any treatments with conventional medications.

### Seed and Planting Stock

Under the National Organic Standards, producers must use organic seed and planting stock if it is commercially available. Otherwise, you must use untreated, non-GMO seed, and demonstrate (document) a good faith attempt to find organic seed and planting stock. Finding organic seed and planting stock is not always easy. The box on this page suggests some resources to try.

If the variety you need or its equivalent is not commercially available, you may use conventional seed—if it is not treated with a prohibited substance. A variety can be considered not commercially available if you cannot locate an organic supplier. If there

## Resources to Help Producers Find Organic Seed

### 1. ATTRA's Suppliers of Seed for Certified Organic Production

<[www.attra.ncat.org/attra-pub/altseed.html](http://www.attra.ncat.org/attra-pub/altseed.html)> This is an online list of seed sources. Producers need to get further verification of organic certification of seeds on this list.

ATTRA takes the suppliers' word and doesn't require proof of organic certification. In light of this, please ask for documentation—such as a current organic certificate—when you place your order.

It is clearest and easiest to verify organic status if the supplier lists the seed as organic and includes the name of the certifier on the invoice or packing list. If the seed is not organic, see 2 and 3.

### 2. OMRI Certified Organic Seed and Planting Stock List

<[www.omri.org/OMRI\\_SEED\\_list.html](http://www.omri.org/OMRI_SEED_list.html)> These items are unquestionably certified organic. However, this list represents only a small fraction of the seed suppliers who offer organic seed.

### 3. Save Our Seed's Certified Organic Seed Sourcing Service

<[www.savingourseed.org/pages/sourcing.htm](http://www.savingourseed.org/pages/sourcing.htm)> This free online service lets producers know if a particular organic seed is available. Producers fill out a simple form with type of plant (e.g., clover), variety (e.g., berseem), and quantity (e.g., 50 lb.) needed. A response is mailed within five days with documentation that would be acceptable to any certifier.



is an organic source, it might still be commercially unavailable if the supplier can't provide the quantity or quality needed. Quality can be considered substandard if there is seed-borne disease, very low germination percentages, high noxious weed seed content, and the like. The higher cost of organic seed and stock is NOT considered an argument for not purchasing available organic seed.

If you need to use non-organic seed, you must demonstrate that you tried to source organic. Although the regulations do not specify a number, most certifiers will expect reasonable documentation that you contacted three seed suppliers likely to carry organic seed. You should also be prepared to document that non-organic stock is not genetically engineered. As mentioned, be certain you are using untreated seed. Most conventional seed treatments are prohibited.

A few additional comments should be made regarding seed and planting stock requirements. The requirement for organic seed applies to any kind of seed—whether it is crop, cover crop, or pasture seed. Legume inoculants must be non-GMO. Buyer beware. Get written documentation if there is any question about whether seed has been treated or if seeds or inoculant might be genetically modified.

Finally, if you are sprigging a pasture—as is commonly done with bermuda grass—or are interplanting comfrey or some other perennial, the standards are not especially clear. Be certain to ask your certifier how such planting stock is classified. Annual transplants must be organic. Perennial planting stock must be organic if commercially available. If not commercially available, it must be managed organically for 12 months before harvest.

Your certifier will determine whether there is a need to delay grazing, and if so, for what period of time. A certifier can also offer guidance on sufficient documentation for any of the above issues. The National Organic Standard on this subject (Sect. 205.204[4]) is open to several



*Finding sources of organic seed can be a challenge, but ATTRA's Web site has tools that can help. Photo from the OSU Forage Information System Web site.*

interpretations, and your certifier will decide how you must deal with these situations.

### ***Documents to Keep***

The kinds of documents you need to retain for organic pasture record-keeping are the same as for other crops. Activities affecting the land, materials used on it, and monitoring must be documented. You will need a running field history, especially if you have rotation pasture with permanent paddocks. You will probably already be keeping records on when animals enter and leave each paddock. Keep track of other field activities like mowing and the dates of those activities. Such records are useful for your own information on your farm management as well as for organic compliance.

You will want the same sort of record of any materials applied for fertilization or pest control purposes. Because seed is also an input, keep any documents related to seed and planting stock you use, including labels or packets, invoices, documentation of your searches for organic seed, if you used conventional seed, as well as documents that show it is untreated and not genetically engineered. If you used

inoculants for legume seeds, the purchase records should also be kept.

Save your labels and purchase receipts for any fertilizers or pest control products you buy. Keep all soil and water test reports. And of course, keep harvest and sales records. Harvest records are important as evidence of the source of organic feed. These should include the field location, harvest quantity, and date.



Good grazing management averts many pest problems for both forages and animals. Photo by Alice Beetz, NCAT.



These dense pastures provide excellent nutrition for healthy animals and good milk production. Photo by Linda Coffey, NCAT.

## Conclusion

In order to manage a pasture organically you must pay very close attention to soil and forage plants. This publication does not go into the details of what this skilled management entails. Rather, it outlines the boundaries within which you must operate to comply with the National Organic Standard. If you produce livestock for eventual export, the requirements might be different. International regulations vary only slightly on most issues except in the area of what is allowed regarding manure from “factory farms.” Your certifier can help you learn more if you are considering producing for the international market.

Many other ATTRA publications address the nuts and bolts of managing cropland and pastures sustainably. Grazing systems, soil and weed management, and marketing resources are the subjects of publications available cost-free to farmers, ranchers, and those who work with them. Many can be downloaded from the ATTRA Web site ([www.attra.ncat.org](http://www.attra.ncat.org)) and all can be obtained by requesting them with a call to 800-346-9140. *The Organic Livestock Workbook* is especially recommended.

The ATTRA publication *Organic Certification Process* orients the user to the procedures for certification. *Preparing for an Organic Inspection: Steps and Checklists*, reminds producers about all of the documents needed to meet a commitment to maintaining pasture as organic. Sample forms and letters have also been developed. These are available on the ATTRA Web site or can be obtained by calling 800-346-9140 and requesting a copy.

Clearly understand that the certifier makes the determination when there is a question about any material or activity related to your certified organic pasture. Choose your certifying agency carefully and work with staff as cooperatively as possible. The certification office staff and your inspector can help you understand the standards as they apply to your operation.

## References

---

Anon. 2000. Boosting organic matter in soil may help create ideal soil conditions for weed-suppressing microbes called deleterious rhizobacteria (DRB). Quarterly Report of Selected Research Projects (Agricultural Research Service, U.S. Department of Agriculture). July 1 to September 30, 2000. p. 14.

Ingham, Elaine. 2000. The Vermicompost foodweb: Effects on plant production. Oral Scientific Sessions, The Vermillenium (Conference). Kalamazoo, MI. September 21.

Ingham, Elaine. 2004. Biodiversity just under our feet. The Fire of Creation, Episode 3 of Sacred Balance TV Series. [www.sacredbalance.com/web/drilldown.html?sku=82](http://www.sacredbalance.com/web/drilldown.html?sku=82)

Sheley, R.L., T.J. Svejcar, B.D. Maxwell, and J.S. Jacobs. 1999. Healthy Plant Communities, MT199909 AG. Bozeman, MT: Montana State University Extension.

## Further Resources

National Organic Program

A site that includes considerable information on

certifying agencies; consumer information; NOP Regulations (standards) and guidelines; producers, handlers, processors, and retailers; and state programs and cost-share opportunities. [www.ams.usda.gov/nop/indexNet.htm](http://www.ams.usda.gov/nop/indexNet.htm)

Certifying Agencies in the United States

A list of USDA-accredited certifying agents. [www.ams.usda.gov/nop/Certifying Agents/Accredited.html](http://www.ams.usda.gov/nop/Certifying%20Agents/Accredited.html)

Organic Materials Review Institute (OMRI)

A nonprofit organization that reviews substances for use in organic production, processing, and handling to ensure compliance with USDA National Organic Program standards. [www.omri.org](http://www.omri.org)

Save Our Seed's Certified Organic Seed Sourcing Service. A service to help producers find documented organic seed or alternatives, if organic seed sources are not found. [www.organicseedsourcing.com](http://www.organicseedsourcing.com)

Lindemann, W.C. and C.R. Glover. 2003. Nitrogen Fixation by Legumes, Guide A-129. Las Cruces, NM: New Mexico State University Extension.

## Notes

---

**Pastures: Going Organic**

By George L. Kuepper and Alice Beetz

NCAT Agriculture Specialists

©NCAT 2006

Paul Driscoll, Editor

Karen Van Epen, Production

This publication is available on the Web at:

[www.attra.ncat.org/attra-pub/pastures\\_organic.html](http://www.attra.ncat.org/attra-pub/pastures_organic.html)

or

[www.attra.ncat.org/attra-pub/PDF/pastures\\_organic.pdf](http://www.attra.ncat.org/attra-pub/PDF/pastures_organic.pdf)

IP297

Slot 293

Version 011607

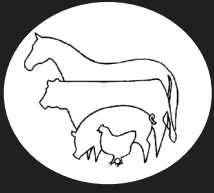

LIVESTOCK

MOSES ORGANIC FACT SHEET

# Transitioning to Organic Sheep or Goat Dairy Production

**T**hose wishing to sell an organic goat or sheep dairy product must make that product from certified organic milk. A herd or flock will produce organic milk only if the rules outlined through the National Organic Program are followed. For more information, see the MOSES “Guidebook to Organic Certification” or the book “Organic Dairy Farming,” which, though written with a cow dairy emphasis, will be extremely relevant to goat or sheep dairy. Both are available from MOSES.

- All production animals (milking animals, youngstock, dry animals) must be fed organic feed for 12 months prior to selling organic milk. This feed may come from your own fields that are in their third year of organic transition. Any purchased feed must have a certificate of current certified organic status. Organic feed may not come from genetically modified crops.
- Because organic pasture is required (see below), it will generally take 36 months to begin producing organic milk. Land will not be eligible for certification until 36 months have passed since last application of non-approved materials.
- No prohibited health materials or feed supplements are to be fed or used in the 12 months previous to selling organic milk (no antibiotics, non-approved parasiticides, no minerals or vitamins with prohibited additives such as mineral oil or artificial flavorings).
- Animals may not be brought in and out of organic production. Once an animal is certified organic, they must stay organic unless permanently removed.
- Individual replacement animals must be born or purchased from a certified organic operation. Groups or entire herds/flocks may be added, but must go through a one year transition period before producing organic milk.
- Rams or bucks need not be certified organic unless

they will be sold as slaughter animals. Artificial insemination is allowed. Breeding hormones are not allowed.

- Any animals sold for organic slaughter must be raised under organic management from the last third of gestation.



- Anyone producing organic milk must be certified by a third-party certification agency. Your operation will be inspected annually, and a fee that generally runs between \$300 and \$600 per year will be charged. There may be cost-share available to help with certification costs. Check with your state department of agriculture.

*All production animals must be fed organic feed for 12 months prior to selling organic milk.*

- Detailed record keeping, including tracking of individual animals, is required.

**Pasture is mandated for all ruminants.** Pasture is defined as offering feed value to the animals. Animals in all stages of production (including young stock and dry animals) must be out on pasture that offers feed value for a significant portion of the day, when seasonally appropriate. Green chop or dry hay fed to animals is not considered “pasture”. Sheep or goats must be grazing the pasture themselves and a dry lot is not considered pasture, since there is no covering on the ground that offers feed value. Youngstock should be out on pasture once they have developed rumens and can digest grass. Browse in a paddock is acceptable for goats, as long as it offers significant feed value.

Pasture must be certified organic. The transition to organic land is 36 months from last application of non-approved materials.

**Plan to feed a high forage diet consisting of high quality feeds to promote the health of your animals.** Preventative health support, breeding and a clean, low-stress living environment are an organic producer's best health tools. Vaccines are allowed.

**Parasiticides are, in general, not allowed for regular use in organic production.** Ivermectin may be used in emergency cases and only when the animal is not producing organic milk. Parasites can be controlled through pasture management, allowed herbal remedies and breeding for resistance.

**Any milk replacer must be from non-rBGH treated animals.** As of spring 2007, non-rBGH milk replacer is not available in the U.S. Organic lambs or kids may be raised on certified organic milk from cows, goats or sheep.

**Animals must be individually identified** by ear tags, neck tags or distinguishing photos or drawings for animals that can be uniquely identified. Corresponding individual animal health records must be maintained for each individual animal. Health records must include all health events including birth records. Even if an animal is only stripped clean to control mastitis, this should be noted in her individual health record in order to verify organic management. Record keeping aids farmers in understanding what products and activities are useful and which are not, as well as tracking genetic traits to aid with culling decisions.

**No antibiotics or hormones are allowed in organic production.** However, an organic farmer cannot withhold medical treatment to preserve the organic status of an animal. If antibiotics must be used as a last resort remedy, the animal should be treated and sold or tracked and managed as nonorganic. This includes younstock that are born on the farm after your operation is certified organic. Once an animal that is part of your organic operation is given an antibiotic, this animal cannot ever be an organic dairy or slaughter animal. Animals that had been given antibiotics before you started your one-year of conversion to organic milk production can be converted to organic.

**Housing must allow for freedom of movement and ventilation to promote animal health.** This includes all stages of the animal's life. Any bedding that

the animals eat or chew on must be certified organic.

Treated wood where there is contact with livestock or with soil growing organic crops cannot be used on any new construction once the operation is certified organic. If the treated wood is present before the operation is fully organic, it can remain. Sheep or goats can be confined during winter months, but should have a few hours of outside exercise when weather permits. Youngstock can be confined when young to prevent illness.



**Verify with your certification agency that the vitamins and minerals you are feeding meet the organic standards** and do not contain any prohibited synthetic or non-organic substances (such as artificial preservatives, colorings, flavorings, anticaking agents or dust suppressants).

**Verify with your certification agency that all health products used are acceptable.** Dehorning, castration and tail docking in sheep should be performed to provide the least amount of stress to the animal.

**You must ensure that pastures and manure application do not cause soil erosion or pollute ground or surface water.** Plastic silage or hay wraps cannot be burned.

**Before you begin your organic transition, find a market for your organic milk and decide on your organic certification agency.** Work with the organic certification agency and time your first inspection to occur no later than 4 months before your shipper can pick up your organic milk.

MIDWEST ORGANIC  
& Sustainable Education Service  
MOSES

Visit [www.mosesorganic.org](http://www.mosesorganic.org) for more resources and tools, including our Organic Resource Directory and the Organic Broadcaster Newspaper. Plan to attend our annual Organic Farming Conference in February. To find upcoming events including MOSES trainings and field days visit our web calendar at: [www.mosesorganic.org/events.html](http://www.mosesorganic.org/events.html)

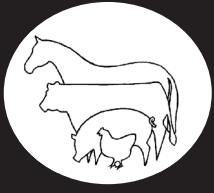

LIVESTOCK

MOSES ORGANIC FACT SHEET

# Transitioning to Sheep or Goat Meat Production

**A**nimals sold for organic meat must be raised under organic management from the last third of gestation. For small ruminants such as goats and sheep with a five month gestation, this means the mother animal must be treated organically for a minimum of 50 days. Any dairy animals sent to organic slaughter must be born from mothers treated organically for at least the last 50 days of gestation.

- All animals raised for organic slaughter must be fed 100% organic feed during their entire lifetime. Any purchased feed must have a certificate of current certified organic status. Organic feed may not come from genetically modified crops.

- During transition or once organic, stored feed such as hay may only be fed if it is harvested from a certified organic field.

- Pasture is required (see below). Land will not be eligible for certification until 36 months have passed since the last application of non-approved materials.

- No prohibited health materials or feed supplements are to be fed or used in either the gestating mother during the last 50 days or during the organic meat animal's lifetime (no antibiotics, non-approved parasiticides, no minerals or vitamins with prohibited additives such as mineral oil or artificial flavorings).

- Organic breeding animals may not be brought in and out of organic production. Once an animal is certified for organic production, they should stay in production unless permanently removed.

- Rams or bucks need not be certified organic unless they will be sold as slaughter animals. Artificial insemination is allowed. Breeding hormones are not allowed.

- Anyone producing animals for organic slaughter must be certified by a third-party certification agency. Your operation will be inspected annually, and a fee that generally runs between \$300 and \$600 per year will be charged. There may be cost-share available to help with certification costs. Check with your state department of agriculture.

- Detailed record-keeping is required, including records of individual animals.

- Organic animals must be slaughtered in a plant certified for organic slaughter.



*Pasture is mandated for all organic ruminants.*

## **Pasture is mandated for all organic ruminants.**

Pasture is defined as offering feed value to the animals. Animals in all stages of production (including young stock) must be out on pasture that offers feed value for a significant portion of the day, when seasonally appropriate. Green chop or dry hay fed to animals is not considered "pasture". Sheep or goats must be grazing the pasture themselves and a dry lot is not considered pasture, since there is no covering on the ground that offers feed value. Youngstock should be out on pasture once they have developed rumens and can digest grass. Browse in a paddock is acceptable for goats, as long as it offers significant feed value. Pasture must be certified organic. The transition to organic land is 36 months from last application of non-approved materials.

**Plan to feed a high forage diet consisting of high quality feeds to promote the health of your animals.** Preventative health support, breeding and a clean, low-stress living environment are an organic producer's best health tools. Vaccines are allowed.



*Before you begin your organic transition, find a market for your organic meat.*

**Parasiticides are not allowed for use in organic slaughter animals.** Parasites can be controlled through pasture management, allowed herbal remedies and breeding for resistance.

**Any milk replacer must be from non-rBGH treated animals.** As of spring 2007, non-rBGH milk replacer is not available in the U.S. Organic lambs or kids may be raised on certified organic milk from cows, goats or sheep.

**Animals must be individually identified** by ear tags, neck tags or distinguishing photos or drawings for animals that can be uniquely identified. Corresponding individual animal health records must be maintained for each individual animal. Health records must include all health events including birth records. Record keeping aids farmers in understanding what products and activities are useful and which are not, as well as tracking genetic traits to aid with culling decisions.

**No antibiotics or hormones are allowed in organic production.** However, an organic farmer cannot withhold medical treatment to preserve the organic status of an animal. If antibiotics must be used as a last resort remedy, the animal should be treated and sold or tracked and managed as non-organic. This includes youngstock that are born on the farm after your operation is certified organic. Once an animal that is part of your organic operation is given an antibiotic, this animal cannot ever be an organic dairy or slaughter animal. Animals that had been given antibiotics before you began managing them organically to produce their first organic lamb or kid can be converted to organic.

**Housing must allow for freedom of movement and ventilation to promote animal health.** This includes all stages of the animal's life. Any bedding that the animals eat or chew on must be certified organic. Treated wood where there is contact with livestock or with soil growing organic crops cannot be used on any new construction once the operation is certified organic. If the treated wood is present before the operation is fully organic, it can remain. Sheep or goats can be confined during winter months, but should have a few hours of outside exercise when weather permits. Youngstock can be confined when young to prevent illness.

**Verify with your certification agency that the vitamins and minerals you are feeding meet the organic standards** and do not contain any prohibited synthetic or non-organic substances (such as artificial preservatives, colorings, flavorings, anticaking agents or dust suppressants).

**Verify with your certification agency that all health products used are acceptable.** Dehorning, castration and tail docking in sheep should be performed to provide the least amount of stress to the animal.

**You must ensure that pastures and manure application do not cause soil erosion or pollute ground or surface water.** Plastic silage or hay wraps cannot be burned.

**Before you begin your organic transition, find a market for your organic meat and decide on your organic certification agency.** Begin working with the organic certification agency no later than six months before you have animals ready for slaughter.

MIDWEST ORGANIC  
& Sustainable Education Service  
MOSES

Visit [www.mosesorganic.org](http://www.mosesorganic.org) for more resources and tools, including our Organic Resource Directory and the Organic Broadcaster Newspaper. Plan to attend our annual Organic Farming Conference in February. To find upcoming events including MOSES trainings and field days visit our web calendar at: [www.mosesorganic.org/events.html](http://www.mosesorganic.org/events.html)

-updated January 2007



# Organic Production

## Additional Resources

### ATTRA Publications

#### NCAT's Organic Livestock Workbook

This workbook has been created to help organic and transitional producers with livestock or mixed crop and livestock operations understand the range of practices and materials allowed under the National Organic Program Regulations. Particular emphasis is placed on farming strategies and practices that promote sustainability.

#### Organic System Plans: Livestock Production

If you want to certify your livestock operation(s) as organic, you will need an organic system plan. This guide was developed to assist you in completing the application for organic certification by explaining just what information certifiers want in a system plan and why it is required.

#### Organic Livestock Documentation Forms

In order to become certified organic, livestock producers must demonstrate to an accredited certifier that their operation complies with National Organic Program regulations. The 32 forms in this package are provided as tools that livestock producers can use for documenting practices, inputs, and activities that demonstrate compliance with regulations or that assist in other aspects of farm record keeping.

#### Organic Standards for All Organic Operations: Highlights of the USDA's National Organic Program Regulations

This collection of excerpts from the USDA's National Organic Program (NOP) Final Rule provides the reader with key standards relevant to all certified organic operations.

#### Organic Standards for Livestock Production: Highlights of the USDA's National Organic Program Regulations

This collection of excerpts from the U.S. Department of Agriculture's National Organic Program (NOP) provides the reader with key standards relevant to organic livestock producers.

#### Organic Livestock Feed Suppliers Database

One of the challenges of organic livestock production is locating the 100% organic feed required. This self-listing database helps producers locate sources of feed. Available only online at [http://attra.ncat.org/attra-pub/livestock\\_feed](http://attra.ncat.org/attra-pub/livestock_feed).

### Books

#### Alternative Treatments for Ruminant Animals

Dettloff, Paul, DVM. 2004. Acres USA, Austin, TX . 246 p. [www.acresusa.com/books/closeup.asp?prodid=1236&catid=11&pcid=2](http://www.acresusa.com/books/closeup.asp?prodid=1236&catid=11&pcid=2)

This book provides information on natural, organic, and sustainable approaches to animal health. Includes information for sheep and goats.

#### Living With Worms in Organic Sheep Production

Stockdale, Peter. 2008. Canadian Organic Growers, Inc., Ontario, Canada. 79 p.

An excellent book that covers parasite life cycles, managing pastures and animals to prevent parasitism, diagnosis and treatment of internal parasites.

### Web sites

#### National Organic Program

[www.ams.usda.gov/AMSV1.0/nop](http://www.ams.usda.gov/AMSV1.0/nop)

Link to standards: <http://ecfr.gpoaccess.gov/cgi/t/text/text-idx?c=ecfr&sid=89916dd414d154b401d29376f730a9b7&rgn=div5&view=text&node=7:3.1.1.9.32&idno=7>

List of certifiers: [www.ams.usda.gov/AMSV1.0/getfile?docName=STELPRDC5074486](http://www.ams.usda.gov/AMSV1.0/getfile?docName=STELPRDC5074486)

#### New Farm (Rodale)

[www.rodaleinstitute.org/new\\_farm](http://www.rodaleinstitute.org/new_farm)

Certifier directory: [www.rodaleinstitute.org/certifier\\_directory](http://www.rodaleinstitute.org/certifier_directory)

#### Organic Trade Association Organic Pages Online

[www.theorganicpages.com/topo/index.html](http://www.theorganicpages.com/topo/index.html)